



Treasury Board of Canada  
Secrétariat

Secrétariat du Conseil du Trésor  
du Canada

## CLASSIFICATION STANDARD

### **AGRICULTURE**

#### **Scientific and Professional Category**

# CLASSIFICATION STANDARD

## AGRICULTURE

### **SCIENTIFIC AND PROFESSIONAL CATEGORY**

Issued by:  
Classification, Human Resources  
Information Systems and Pay Division  
Personnel Policy Branch 1987

© Minister of Supply and Services Canada 1987



CONTENTS

	<u>PAGE</u>
INTRODUCTION	1
CATEGORY DEFINITION	3
GROUP DEFINITION	4
FACTORS	5
BENCH-MARK POSITION DESCRIPTION INDEX	
In Ascending Order of Level	16
In Alphabetical Order	17
BENCH-MARK POSITION DESCRIPTIONS	1.1

## INTRODUCTION

This standard describes the plan to be used to classify positions allocated to the Agriculture Group. It consists of an introduction, definition of the Scientific and Professional Category and the occupational group, factor definitions and characteristics, degree highlights and bench-mark position descriptions.

The ultimate objective of job evaluation is the determination of the relative values of jobs in each occupational group. A classification plan of five levels, representing significant differences in the difficulty of the work, has been established for this group. Jobs assigned to a given level are regarded as being of equal difficulty.

### Factors

The evaluation of positions and their assignment to a classification level will be determined by the application of five factors:

- Kind of Assignments
- Complexity of Work Professional
- Responsibility Management
- Responsibility
- Impact of Recommendations and Activities

Each factor is described, and the descriptions designate the features of the work assigned to positions allocated to the group. A list of characteristics is included for each factor. The characteristics indicate the features of the work that are to be considered when evaluating a position under a particular factor. Each characteristic describes the lowest and the highest requirement. The factor characteristics serve to ensure that consideration is given to all features of the work of a position.

Because of the nature and diversity of positions in this group, it was not considered possible to produce, for all degrees of the factors, meaningful definitions that would describe and distinguish the increasing difficulty of the work from the lowest to the highest degree. As a result, degree highlights describe the features of the work that will be found in most positions at these levels. The second to fifth degrees of each factor are illustrated by one or more bench-mark position descriptions.

### Bench-mark Positions

Bench-mark position descriptions exemplify the degrees of each factor and the levels of the classification plan. Each bench-mark consists of a descriptive title, a statement of the principal duties and a set of specifications describing the features of the work of the position in terms of the characteristics of each of the five factors. The specifications exemplify the application of the evaluation plan to the duties and responsibilities of the bench-mark position and indicate the degree assigned to the position for each factor. A classification level is assigned to each bench-mark position.

### Use of the Standard

There are six steps in the application of this classification standard.

1. the position description is studied to ensure understanding of the position as a whole and of the nature of the duties and responsibilities as they relate to the characteristics of each factor. The relationship of the position being studied to positions above and below it in the organization is also studied.

2. Allocation of the position to the category and group is confirmed by reference to the definitions and the descriptions of inclusions and exclusions.
3. A degree under each factor is tentatively assigned to the position being evaluated by considering the duties and responsibilities of the position in relation to the range described for each factor characteristic and the degree highlights for the factor; and determining that the difficulty of work is equal to, or greater or less than a degree that is described. The features of the work of the position being evaluated should be related to the degree highlight as a whole in its total context, not to isolated words or phrases.
4. The degree tentatively assigned is confirmed by comparison with the bench-mark position descriptions.
5. The level of the position is determined by the degree that has been assigned to the position for at least three of the five factors. When one degree does not predominate, raters are to compare the total job with the bench-mark position descriptions and determine the level that best corresponds on the whole with the duties and responsibilities of the position.
6. The position is compared with bench-mark position descriptions that have been assigned to the same level, as a check on the validity of the level selected.

CATEGORY DEFINITION

Occupational categories were repealed by the Public Service Reform Act (PSRA), effective April 1, 1993. Therefore, the occupational category definitions have been deleted from the classification standards.



GROUP DEFINITION

For occupational group allocation, it is recommended that you use the [Occupational Group Definition](#) and [the Occupational Sub-group Definition Maps](#), which provide the 2005 group and sub-group definition and their corresponding inclusion and exclusion statements. The maps explicitly link the relevant parts of the overall 2005 occupational sub-group definition to each classification standard.

AGRICULTUREFACTORS

KIND OF ASSIGNMENTS

COMPLEXITY OF WORK

PROFESSIONAL\_ RESPONSIBILITY

MANAGEMENT RESPONSIBILITY

IMPACT OF RECOMMENDATIONS AND ACTIVITIES

KIND OF ASSIGNMENTS

This factor is used to measure the difficulty of the work in terms of its objectives and extent, the variety of activities and the scope for planning and conducting work.

When evaluating positions under this factor raters are to consider the following characteristics:

The objectives established by others for the conduct of the work, ranging

- from objectives and instructions provided for each work operation,
- to objectives described in terms of policy.

The extent of the work ranging

- from a part or phase of a project or study, or a continuing operation requiring limited investigation, within a single field of specialization,
- to a complete program involving several studies being conducted simultaneously within a broad spectrum of fields of specialization and normally requiring intensive investigation.

The variety of activities, ranging

- from a succession of tasks comprised of a limited number of activities and closely resembling one another in most aspects,
- to a broad spectrum of scientific and administrative activities different from one another in most aspects.

The scope for planning and conducting work, ranging

- from planning the approaches and use of techniques in performing straightforward tasks,
- to planning, coordinating and implementing a program and contributing to the formulation of policy.

KIND OF ASSIGNMENTS

Degrees	Bench-mark Position Descriptions	
1	<u>No.</u>	<u>Page</u>
<p>The work is normally performed within a single field of specialization and consists of either the conduct of continuous laboratory or field operations or a succession of studies that are related to one another and form a part of a larger project, requiring varying degrees of intensity of investigation within the limits of the assignments. Activities differ from one another in several aspects, and include surveying, observing and analyzing the production, processing, and merchandising of agricultural commodities; allocating work; supervising support staff and providing advice. Studies are planned, approaches are developed and methods are determined to ensure that the work meets clearly defined objectives.</p>	<p>2</p> <p>1 District Program Officer, Import/Export Plant Products</p> <p>2 District Program Officer, Plant Products and Pesticides</p>	<p>1.2</p> <p>2.1</p>
3	<p>3 Regional Program Officer, Livestock Grade Standards</p> <p>4 Regional Program Officer, Feed and Fertilizer</p>	<p>3.2</p> <p>4.2</p>
<p>The work is normally performed within a number of related fields of specialization and consists of one or more complete studies or projects conducted simultaneously and requiring varying degrees of intensity of investigation. Activities differ from one another in many aspects and include organizing, controlling and supervising the work of subordinate staff engaged in the conduct of analyses and investigations; controlling funds, facilities and other resources; providing advice and co-ordinating the work with other activities. Projects are planned, problems are defined, approaches are determined and work is delegated to ensure that broadly defined objectives are achieved within financial and other resource limitations.</p>	<p>4</p> <p>5 District Manager - London</p>	<p>5.2</p>
5	<p>6 Regional Program Manager, Alberta, Plant Products</p> <p>7 Associate Director - Dairy Products</p>	<p>6.2</p> <p>7.2</p>
<p>The work is performed within a broad spectrum of related fields of specialization requiring varying degrees of intensity of investigation, and comprises all or a significant part of a program. Activities differ from one another in most aspects and include evaluating and authorizing or making recommendations on project proposals; assessing the implications of work progress on program objectives; providing guidance on the determination of approaches to complex problems; contributing to the development of and directing and co-ordinating a program; and participating in activities at the national and international level. The program is implemented by defining projects and establishing administrative and financial guidelines to ensure that program objectives are achieved within budgetary and other limitations.</p>	6	

COMPLEXITY OF WORK

This factor is used to measure the difficulty of the work in terms of the nature of information and data used, the influences external to the work, the nature and purpose of contacts made with others, and the requirement for the application or development of approaches, practices and techniques and the application of theoretical and subject-matter knowledge.

When evaluating positions under this factor raters are to consider the following characteristics:

The availability of, and the problems involved in obtaining information and data, ranging

- from information and data obtained from scientific literature and other readily accessible sources,
- to the selection of information and data obtained with great difficulty from obscure sources, or requiring the development of sources, or by intensive study and investigation.

The nature of information and data, ranging

- from straightforward information that can be readily verified or that has been verified by others,
- to conflicting information and data requiring great ingenuity or highly selective judgement to obtain and use and that can be verified only by difficult investigation.

The requirement to communicate with others, ranging

- from discussions with persons having similar interests, for such purposes as exchanging or obtaining information,
- to discussions with persons representing conflicting interests, for such purposes as reaching agreement on matters affecting the Canadian agriculture industry.

The requirement for the development or application of approaches, practices and techniques, ranging - from applying conventional approaches, practices and techniques in a limited subject-matter area,

- to developing concepts and novel approaches, practices and techniques in a variety of subject-matter areas.

The requirement for the application of theoretical and practical knowledge, ranging

- from a thorough knowledge of the principles and theories of a discipline and some familiarity with its practices,
- to an advanced knowledge of the principles, theories and practices of a discipline, and a thorough knowledge of related fields.

COMPLEXITY OF WORK

Degrees	Bench-mark Position Descriptions	
	No.	Page
1		
<p>The work requires selecting and using information and data obtained by direct observation or collection or received from other sources. Data is verified and inconsistencies resolved. Collecting and exchanging information and discussing problems requires contacts with others working in the field of specialization or in related fields. Approaches are developed and problems solved by applying a thorough knowledge of the principles, theories and practices of a discipline and adapting practices and techniques. The work normally requires some familiarity with the practices in related fields.</p>	<p>2</p> <p>1 District Program Officer, Import/Export Plants 2 District Program Officer, Plant Products and Pesticides</p>	<p>1.2 2.2</p>
3	3 Regional Program Officer, Livestock Grade Standards	3.2
4	4 Regional Program Officer, Feed and Fertilizer	4.2
5	5 District Manager - London	5.2
6	6 Regional Program Manager, Alberta, Plant Products and Plant Health	6.2
6	7 Associate Director, Dairy Products	7.2
6	<p>The work requires directing the collection, selection and validation of data and using it in evaluating proposals; guiding the planning or implementing of a program; and interpreting and translating general objectives into specific projects relative to the development and implementation of the work program. Participation in meetings at which conflicting interests are represented and agreements are negotiated that significantly affect a program and the Canadian agriculture industry requires contacts with specialists and officials at the national and international level. New concepts and novel approaches are developed and problems solved by applying an advanced knowledge of the principles, theories and practices of a discipline and a thorough knowledge of related fields or subject-matter areas.</p>	

PROFESSIONAL RESPONSIBILITY

This factor is used to measure the difficulty of the work in terms of the professional leadership received. It is also used to measure the requirement to exercise professional judgement in interpreting results and findings and providing advice.

When evaluating positions under this factor raters are to consider the following characteristics:

The professional leadership received, ranging

- from guidance as work is progressing,
- to guidance on the nature and objectives of a program.

The requirement to interpret results of work, ranging

- from ensuring that own observations are meaningful and consistent,
- to evaluating conclusions and recommendations of others determining the need for extension or modification of a program.

The requirement to give advice, ranging

- from providing advice to colleagues and support staff on matters closely related to the work,
- to providing authoritative advice on a variety of subject-matter areas of national or international concern to other specialists or senior officials.

PROFESSIONAL RESPONSIBILITY

Degrees	Bench-mark Position Descriptions	
	No.	Page
Objectives of assignments are clearly defined and professional guidance is received on unusual features. Completed work, conclusions and recommendations are reviewed for consistency and soundness of judgement. The work of subordinate professional and support staff is reviewed in progress and on completion to determine the effectiveness of methods and techniques. The results of studies are interpreted to determine their implications on the attainment of defined objectives and related activities. Advice is provided to colleagues, associates and support staff on matters concerning the work within own field of specialization.	1	
	2	<p>1 District Program Officer Import/Export Plant Products 1.2</p> <p>2 District Program Officer, Plant Products and Pesticides 2.2</p>
Objectives of assignments are stated in general terms and professional guidance is received on the implications of unusual problems. Recommendations and conclusions are reviewed for soundness of judgement in relation to the attainment of objectives and conformance with directives. The work of subordinate staff, colleagues and other scientists is reviewed in respect of approaches, soundness of judgement and completeness. Results of studies are interpreted to determine the implications of conclusions and recommendations on the objectives of own projects or studies and on external scientific or other activities. Advice on problems and theories in fields related to the work is given to other specialists and officials; advice in own field of specialization is accepted as authoritative.	3	<p>3 Regional Program Officer, Livestock Grade Standards 3.2</p> <p>4 Regional Program Officer, Feed and Fertilizer 4.2</p>
	4	5 District Manager, London 5.2
	5	<p>6 Regional Program Manager, Alberta Plant Products and Plant Health 6.2</p> <p>7 Associate Director, Dairy Products 7.2</p>
Objectives of the work are received in statement of policy and interpretation of policy. Professional guidance is not normally available. Results of own work and conclusions and recommendations are evaluated in relation to policy and other limitations. Work delegated to subordinate professional staff is reviewed for attainment of objectives within established guidelines and resource limitations. Results of studies, conclusions and recommendations are interpreted to determine their broad implications on scientific and other activities at the departmental, national and international level. Authoritative advice and recommendations in a number of related fields of specialization that effectively contribute to the development of a program are provided to other specialists and senior officials.	6	



MANAGEMENT RESPONSIBILITY

This factor is used to measure the difficulty of the work in terms of the responsibility for managing staff, administering resources and co-ordinating work with that of others.

When evaluating positions under this factor raters are to consider the following characteristics:

Responsibility for committing departmental resources, ranging

- from spending own time and using facilities,
- to planning, controlling and approving expenditures of funds for program delivery.

Responsibility for the control of staff, ranging

- from occasionally assigning work to support staff delivering one program,
- to managing a large staff delivering several programs.

Responsibility for the administrative co-ordination of work performed for, or in conjunction with other organizational units, ranging

- from co-ordinating a variety of activities with those of other individuals,
- to co-ordinating a wide spectrum of activities with those of other organizations.

MANAGEMENT RESPONSIBILITY

Degrees	Bench-mark Position Descriptions	
	<u>No.</u>	<u>Page</u>
<p>The work requires assigning tasks to subordinate professional and support staff; planning the use of facilities; and co-ordinating activities that differ from one another in several aspects with those of others.</p>	1	1.2
	2	2.2
	3	3.2
	4	4.2
	3	
	<p>The work requires supervising professional and support staff; estimating costs, controlling and co-ordinating project schedules and the allocation and expenditure of budgeted funds, and co-ordinating activities that differ from one another in many aspects with those of others.</p>	4
7		7.3
5		5.2
<p>The work requires managing a large staff in professional and other occupational groups; evaluating cost-benefit studies; directing the preparation and administration of budgets; and co-ordinating activities that differ from one another in most aspects with those of others.</p>	6	

IMPACT OF RECOMMENDATIONS AND ACTIVITIES

This factor is used to measure the impact of recommendations and activities on departmental work and on the Canadian agriculture industry.

When evaluating positions under this factor raters are to consider the following characteristics:

The impact of recommendations and activities on departmental work, ranging

- from information and results affecting the conduct of studies, projects or a continuing operation,
- to decisions and recommendations affecting the development, initiation, continuation, and conduct of a program.

The impact of recommendations and activities on the Canadian agriculture industry, ranging

- from information and results normally verified by the supervisor before affecting the department's clientele,
- to decisions and recommendations affecting economic development, initiation and continuation of national agricultural industries or businesses.

IMPACT OF RECOMMENDATIONS AND ACTIVITIES

Degrees	Bench-mark Position Descriptions	
	<u>No.</u>	<u>Page</u>
	1	
Recommendations, advice or results of the work affect a continuing operation, projects or further studies in own or related areas of work; and affect the conduct of agricultural industries or businesses.	2	1 District Program Officer Import/Export Plant 1.3
		2 District Program Officer Plant Products and Pesticides 2.2
	3	3 Regional Program Officer Livestock Grade Standards 3.2
		4 Regional Program Officer Feed and Fertilizer 4.2
Recommendations, advice or consultation affect the development and modification of a program and the initiation and conduct of work activities making up a project; contribute significantly to the development, initiation and continuation of agricultural industries or businesses and to improvements in quality control services.	4	5 District Manager, London 5.3
		6 Regional Program Manager Alberta Plant Health and Plant Products 6.3
	5	7 Associate Director Dairy Products 7.3
Recommendations, decisions, advice or consultation affect the formulation of policy concerning a program and the initiation and continuation of projects making up a program; and have substantial consequences on the economic development, initiation and continuation of national agricultural industries or businesses.	6	

BENCH-MARK POSITION DESCRIPTION INDEX

In Ascending Order of Level

<u>Level</u>	<u>Bench-mark Position No.</u>	<u>Descriptive Title</u>	<u>KA</u>	<u>C</u>	<u>PR</u>	<u>MR</u>	<u>1</u>
2	1	District Program Officer, Plant Health and Plant Products	2	2	2	1	2
2	2	District Program Officer, Plant Products and Pesticides	2	2	2	1	2
3	3	Regional Program Officer, Livestock Grade Standards	3	3	3	2	3
3	4	Regional Program Officer, Feed and Fertilizer	3	3	3	2	3
4	5	District Manager, London	4	4	4	5	4
5	6	Regional Program Manager, Plant Health and Plant Products	5	5	5	4	4
5	7	Associate Director - Dairy Products	5	5	5	4	5

BENCH-MARK POSITION DESCRIPTION INDEX

In Alphabetical Order

<u>Descriptive Title</u>	<u>Level</u>	<u>Bench-mark Position No.</u>	<u>Page</u>
Associate Director - Dairy Products	5	7	7.1
District Manager, London	4	5	5.1
District Program Officer, Plant Health and Plant Products	2	1	1.1
District Program Officer, Plant Products and Pesticides	2	2	2.1
Regional Program Manager, Plant Health and Plant Products	5	6	6.1
Regional Program Officer, Feed and Fertilizer	3	4	4.1
Regional Program Officer, Livestock Grade Standards	3	3	3.1

BENCH-MARK POSITION DESCRIPTION

Bench-mark Position Number: 1

Level : 2

Descriptive Title: District Program Officer  
Plant Health and Plant Products

Reporting to the District Manager:

Plans and evaluates the implementation of inspection and enforcement activities to ensure that all plants and plant products imported into and exported from the District comply with the regulations and the Plant Quarantine Act, the Canada Shipping Act, and the Seeds Act. Reviews data produced by the MIS Management Information System. Tracks the district's performance by activity against planned work outputs. Identifies discrepancies, analyses the factors contributing to them, suggests methods to resolve the discrepancy to the District Manager and the Regional Program Officer, for example changes in priorities, human resources allocation, staff training and allocation of equipment. Based on previous year's and current inspection and enforcement activities, recommends work plans for inclusion in the Regional Plans.

Inspects visually and takes samples of materials from (in cooperation with Canada Customs and Health of Animals staff), airfreight cargo, baggage, machinery, containers and vehicles to prevent the entry of hazardous and/or quarantineable agents into Canada. In conjunction with Canada Customs and Animal Health designs a sampling plan and methodology.

Inspects and plans for inspection of mills and export carriers (i.e. box-cars and/or containers) to ensure the phytosanitary regulations of importing countries are met and to ensure that the plants and plants products are free from insect infestation, or contamination by extraneous matter. Negotiates for resources with the district manager, advises and guides staff working on the activity and verifies work objectives are met.

Inspects seeds, examines samples, verifies paper documentation such as permits, phytosanitary certificates and special declarations. Decides to release seeds, order treatment or refuse entry.

Recommends and observes the treatment of infested plants or plant commodities conducted by commercial fumigators. Verifies the appropriateness and effectiveness of products and the method of application. Ensures the problem is eradicated by the treatment.

Observes and verifies the application of chemical and biological control programs by producers for the eradication or management of plant viruses, insects and diseases (e.g. tree fruit viruses, Gypsy Moths, crown gall).

Designs special surveys to determine the presence or the extent of insect infestation or to disclose infection in the agricultural or forestry resources in the district. Coordinates the participation of district technical staff in such surveys. Collates and analyses results and recommends alternative approaches for future activities.

Conducts special investigations in order to identify and contain major disease threats. Verifies suspected problems, identifies the nature of the problem and its solution, takes the corrective measures and ensures in the short- and long-term that the problem has been eradicated. For example when treating a gypsy moth infestation, delineates the area, determines appropriate spray material, conducts spray and chemical control program and conducts a resurvey to determine effectiveness and controls communications relative to the operation.

Advises district technical staff on the consistent and uniform application of the regulations and procedures. Explains and interprets current and proposed legislation, regulations, policies and guidelines to the industry, related agencies, other government departments and the general public. Discusses inspection, investigation and survey results with industry management. Explains remedial measures required.

Develops an annual work plan for the audit of technical staff. Accompanies inspectors on work assignments and evaluates their performance. Identifies training needs, gives on-the-job coaching and administers examinations. Conducts training on such subjects as inspection procedures, quarantine techniques and on the properties and hazards of toxicants and fumigants used in the treatment of inspection sites.

Recommends changes in work projects and in inspection, investigation and survey techniques and procedures. Works cooperatively with industry representatives and colleagues of municipal, provincial and other federal departments.

Degree  
Points

**Specifications**

Kind of Assignments

2

The objectives for the work are well defined in District workplans and are within the scope of regional goals. The work involves a continuing operation in 2 fields of specialty, entomology and pathology and 1 program activity - inspection. A variety of closely related scientific activities are required such as monitoring the inspection and enforcement of plant and plant products and the inspection of mills, storages and export carriers. The work requires the implementation of routine investigations, and import export surveys.

Complexity

2

The work requires the use of data which is readily accessible from the Acts and Regulations, directives, bulletins and the scientific literature. Information relating to pests and diseases is not always straightforward but is identifiable through reference to regional headquarters. The work also requires the exchange of information concerning the interpretation of inspection procedures with departmental staff, customs brokers and the industry. Conventional approaches are applied to work in the 2 subject matter areas of entomology and pathology. The work requires knowledge of the principles and theories of entomology and pathology.

Professional Responsibility

2

Guidance is received following the daily and weekly review of results against activities planned within the district program. The work requires the evaluation of the work of departmental technical staff to ensure the application of standards. Recommendations are made to modify operational practices such as the timing or organization of inspections. Advice is provided to the technical staff and the industry on the interpretation and application of regulations and on methods to correct problems.

Management Responsibility

1

Uses facilities and occasionally assigns work to others. Coordinates activities with technical district staff, trade organizations, importers, exporters, carriers, nurseries, customs brokers and other government departments.



Degree/  
Points

Impact of Recommendations and Activities

2

Information and results affect the program delivery, the conduct of agricultural industries or businesses and the quality of goods in several program areas within the district served by the position.

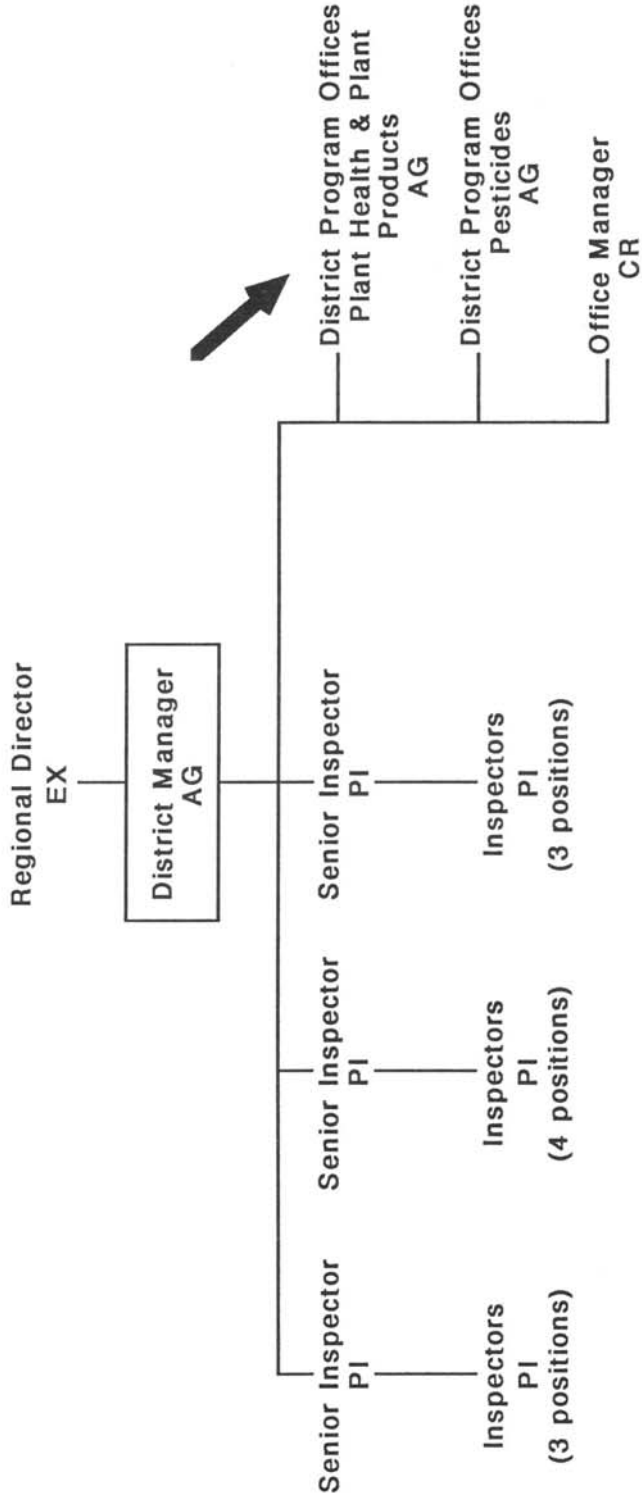

BENCH-MARK POSITION DESCRIPTION

Bench-mark Position Number: 2

Level: 2

Descriptive Title: District Program Officer  
Plant Products and Pesticides

Reporting to the District Manager:

Plans and evaluates the implementation of the inspection and enforcement activities to ensure that all seed, feed, fertilizer and pest control products comply with the regulations and the Seeds Act, the Feed and Fertilizer Act, the Pest Control Products Act and the Pesticides Residue Compensation Act. Reviews data produced by the MIS Management Information System. Tracks the district's performance by activity against planned work outputs. Identifies discrepancies, analyzes the factors contributing to them, suggests methods to resolve the discrepancy to the district manager and the regional program manager; for example changes in priorities, human resources allocation, staff training and allocation of equipment. Based on previous years and current inspection and enforcement activities, recommends work plans for inclusion in the regional plans.

Designs special surveys and investigations to assess the consequences of the use and misuse of pest control products. Organizes and supervises selection of samples dependent on the misuse. Interviews producers and residents in survey areas. Collates and analyses results and recommends alternative approaches for future activities.

Provides scientific and technical advice and regulatory information to district technical staff, to officers of other federal and provincial departments such as Health and Welfare and Environment, industry representatives and the general public in order to resolve problems and to ensure a uniform application and understanding of the acts and regulations, programs, policies and procedures.

Monitors and evaluates district technical staff on the consistent and uniform application of the regulations and procedures. Explains and interprets current and proposed legislation, regulations, policies and guidelines to the industry, related agencies, other government departments and the general public. Discusses inspection, investigation and survey results with industry management, producers and other government departments. Explains remedial measures required. Recommends legal action, where appropriate. Recommends changes in work projects and in inspection, investigation and survey techniques and procedures. Works cooperatively with industry representatives and colleagues of municipal, provincial and other federal departments.

Develops an annual work plan for the audit of departmental technical staff. Accompanies inspectors on work assignments and evaluates their performance. Identifies training needs, gives on-the-job training and administers examinations. Conducts training on such subjects as inspection procedures, properties of pesticides, sampling techniques and identification of samples for exhibits and laboratory work.

<u>Specifications</u>	<u>Degree/ Points</u>
<u>Kind of Assignments</u>	2
The objectives for the work are well defined in District workplans and are within the scope of regional goals. The work involves a continuing operation in 2 fields of specialty, plant pathology and chemistry and several program activities, inspection, enforcement, compliance and advisory. A variety of closely related scientific activities	

are required such as the inspection, enforcement and compliance programs for seed, feed, fertilizer and pest control products. The work requires implementing routine inspection and enforcement activities and surveys.

Complexity

2

The work requires the use of plant information which is readily accessible from manuals and the use of pesticide information which must be obtained from other Branches of the Department. Information relating to plants and pesticides has been verified by others in the Department. The work also requires the exchange of information concerning investigations and projects with departmental staff, producers and the agricultural industry. Conventional approaches are applied to work in the 2 subject matter areas of plant pathology and chemistry. The work requires knowledge of the principles and theories of plant pathology and chemistry.

Professional Responsibility

2

Guidance is received following the daily and weekly review of results against activities planned within the district program. The work requires the evaluation of the work of departmental technical staff to ensure the application of standards. Recommendations are made to modify operational practices such as the timing or organization of inspections. Advice is provided to the technical staff and the industry on the interpretation and application of regulations and on methods to correct problems.

Management Responsibility

1

Uses facilities and occasionally assigns work to others. Coordinates activities with technical district staff, industry associations, manufacturers and other government departments.

Impact of Recommendations and Activities

2

Information and results affect the program delivery, the conduct of agricultural industries or businesses and the quality of goods in several program areas within the district served by the position.

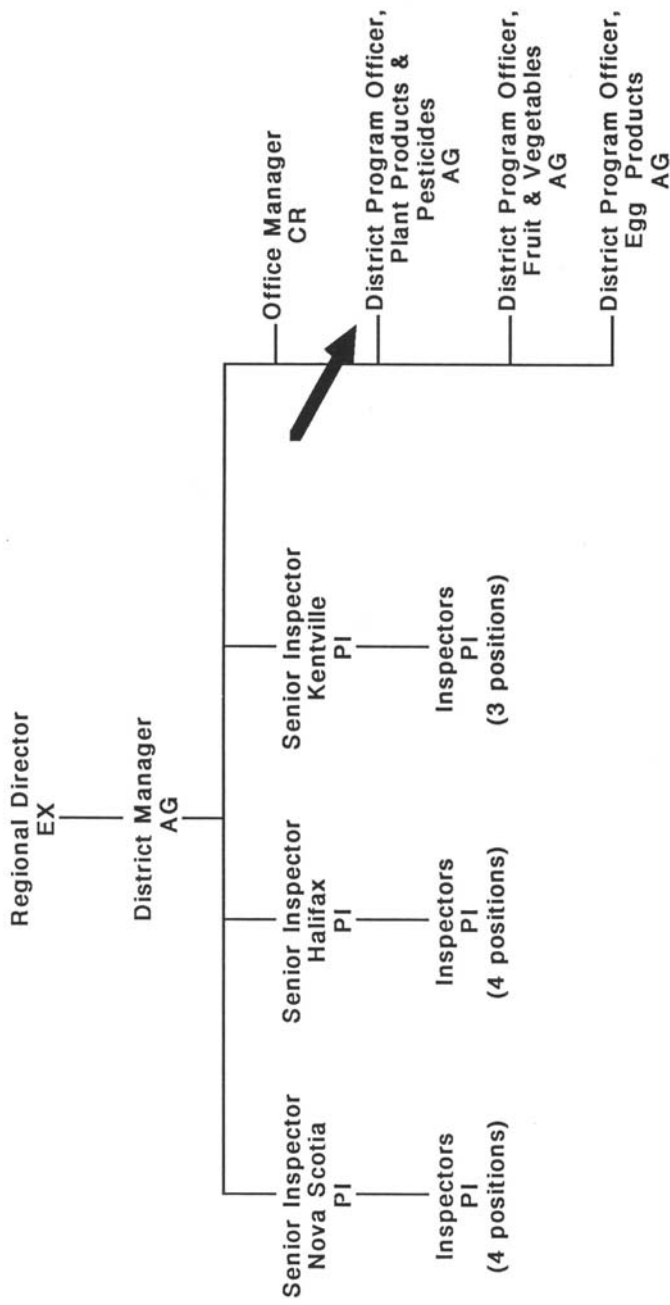

BENCH-MARK POSITION DESCRIPTION

Bench-mark Position Number: 3

Level: 3

Descriptive Title: Regional Program Officer  
Livestock Grade Standards

Reporting to the Regional Program Manager, Livestock Grade Standards:

Advises the Regional Staff, including District managers and inspectors on the consistent and uniform application of the legislation, policies and procedures in the livestock grading program for beef, hog, veal, lamb and mutton. Analyzes contentious problems related to program application and technology. Identifies livestock grading problems peculiar to the Region. Provides authoritative advice, interpretation, information and education relating to legislation and policy to the industry, trade associations, producers, other government departments and agencies. Evaluates inspection, electronic grading systems, electronic data capture systems, pale soft exudative pork detection equipment, technical reviews and legislation and policy issues. Recommends changes to policy and grade standards.

Plans, organizes and evaluates the livestock grading program in the region including the inspection of plants and the assignment of grades to a variety of animals. Reviews data produced by the Management Information System (MIS). Tracks the region's performance by activity against planned work outputs. Identifies discrepancies, analyzes the factors contributing to them and recommends modifications to activity priorities, human resource allocation, resource utilization, revisions in inspection and testing methods and staff training.

Develops an annual work plan for the monitoring of slaughter and meat packing plants. Observes and verifies the inspection, the quality of grading practices and the interpretation of grade standards. Accompanies inspectors in grading activities and evaluates their performance, against national grading standards. Identifies departmental training needs. Develops, plans and conducts training in comprehensive livestock grading procedures and techniques. Evaluates training programs. Discusses local concerns with district offices and provides updates on regional and national activities and policies.

Prepares regional analyses of livestock grading. Estimates, forecasts and recommends the financial and human resources required. Designs performance indicators. Recommends short- and long-term operational and program goals in the area of specialty. Organizes and administers the national grading program within the region and makes recommendations to the national specialty authority. Contributes to the development of the national multi-year operational plan for the regional and for the national specialty Division. Evaluates technical equipment requirements and ensures the maintenance and calibration of instruments.

Designs and conducts special surveys assessing the status of the livestock grading industry and assesses trends and developments. Identifies the regional supply and demand forces, the quality of grading performed, the provincial livestock population, the prevailing disease problems, the import-export situation, the marketing systems available and the impact of provincial government programs on the Livestock Grading area. Writes reports summarizing test and survey information for distribution to meat packing producers, exporters and Marketing Boards. Diagnoses potential problem areas, estimates the effect Regional programs have on segments of the industry and recommends alternate courses of action.

Works cooperatively with plant management, producers, industry organizations and representatives of provincial and other federal departments. Resolves complaints.

**Specifications****Kind of Assignments**

3

The objectives for the work are well defined in regional work plans and are within the scope of national guidelines. The work involves a continuing operation in 1 field of specialty, animal science and 2 program activities, livestock grade standards and unique on-site special surveys. A variety of scientific activities are required such as the evaluation of the livestock grading program and the development and implementation of new procedures and methods. The work requires organizing the regional livestock grading program, special surveys and training.

**Complexity**

3

The work requires the use of some data which is readily accessible from the CAPS (Canada Agriculture Products Standards) Act and manuals and the use of other data which must be assembled from local manufacturing plants' records. The work also requires the resolution of complaints between departmental staff, packing plant management and producers. New grading methods and procedures are tested in the region and recommendations for improvements are made. The work requires knowledge of the principles and theories of animal science and the practices of the livestock production industry in the region.

**Professional Responsibility**

3

Guidance is received following the quarterly review of results against planned regional contributions to the national program. Guidance on specific issues is received following the receipt of complaints. The work requires the evaluation of regional outputs against planned regional productivity levels and national program policy. Recommendations are made on the feasibility of the planned regional contribution to the national activity. Advice is provided to the professional and technical staff and the industry in the Districts on the interpretation of policies, acts, regulations and guidelines and on approaches to correct problems.

**Management Responsibility**

2

Plans own work, uses facilities and occasionally assigns work to others. Coordinates activities with professional and technical departmental regional staff, trade organizations, producers and other government departments.

**Impact of Recommendations and Activities**

3

Decisions affect the program delivery and the conduct of agricultural industries or businesses in one specialty area (Livestock Grading) within the region served by the position. Recommendations for corrective actions and decisions on standards application affect the quality of goods produced. Recommendations are made to the Regional Program Manager on the suspension or cancellation of certificates or on the requirement to prosecute.

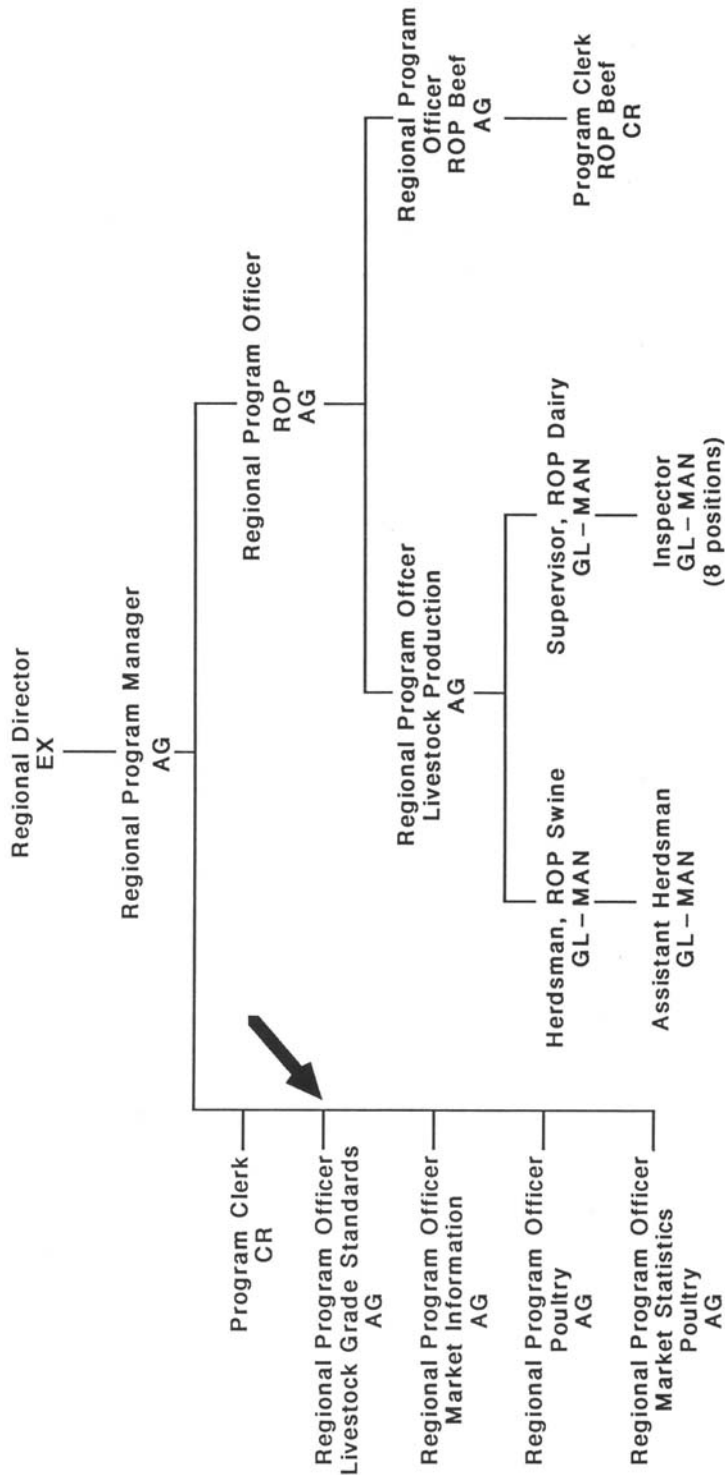



BENCH-MARK POSITION DESCRIPTION

Bench-mark Position Number: 4

Level: 3

Descriptive Title: Regional Program Officer  
Feed and Fertilizer

Reporting to the Regional Program Manager, Plant Health and Plant Products:

Advises the Regional Staff, including District managers and inspectors on the consistent and uniform application of the legislation, policies and procedures in the feed and fertilizer program. Analyzes contentious problems related to program application and technology. Identifies feed and fertilizer production and distribution problems peculiar to the Region. Provides authoritative advice, interpretation, information and education relating to legislation and policy to the industry, trade associations, producers, other government departments and agencies. Evaluates inspection techniques and test methodologies, technical reviews and legislation and policy issues. Recommends changes to policy and developing standards.

Plans, organizes and evaluates the feed and fertilizer program in the region including the inspection of mills and plants. Reviews data produced by the Management Information System (MIS). Tracks the region's performance by activity against planned work outputs. Identifies discrepancies, analyzes the factors contributing to them and recommends modifications to activity priorities, human resource allocation, resource utilization, revisions in inspection and testing methods and staff training.

Develops an annual work plan for the monitoring of inspection activities. Observes and verifies the inspection and the quality of feed and fertilizer classification practices. Accompanies inspectors and evaluates their performance. Identifies training needs. Develops, plans and conducts training in comprehensive feed and fertilizer inspection procedures and techniques. Evaluates training programs. Discusses local concerns with district offices and provides updates on regional and national activities and policies.

Prepares regional analyses of the feed and fertilizer activity. Estimates, forecasts and recommends the financial and human resources required. Designs performance indicators. Recommends short- and long-term operational and program goals in the area of specialty. Organizes the national inspection program within the region and makes recommendations to the national specialty authority. Contributes to the development of the national multi-year operational plan for the regional and for the national specialty Division. Evaluates technical equipment requirements.

Designs and conducts special surveys assessing the status of the feed and fertilizer industry and assesses trends and developments. Identifies the regional supply and demand forces, the supplies available, the import-export situation, and the impact of provincial government programs. Writes reports summarizing test and survey information for distribution to the feed and fertilizer industry, producers and trade associations. Diagnoses potential problem areas, estimates the effect Regional programs have on segments of the industry and recommends alternate courses of action.

Works cooperatively with mill and plant operators, producers, industry organizations and representatives of provincial and other federal departments. Resolves complaints.

**Specifications****Kind of Assignments**

3

The objectives for the work are well defined in regional work plans and are within the scope of national guidelines. The work involves a continuing operation in 2 fields of specialty, feed and fertilizer and several program activities including intensive investigations into the impact of feed additives. A variety of scientific activities are required such as the monitoring of the feed and fertilizer inspection program and the development of standards. The work requires organizing special surveys, investigations and training for the feed and fertilizer specialty.

**Complexity**

3

The work requires the selection and use of data and information which must be assembled from the regulated industry. Information relating to feed and fertilizer survey results and industry claims are often conflicting requiring confirmation through further survey investigation. The work also requires the resolution of complaints between departmental laboratories, the regulated industry and the consuming public. New inspection methods and procedures are tested in the region and recommendations for improvement are made. The work requires knowledge of the principles and theories of chemistry and the practices of the feed and fertilizer production industry in the region.

**Professional Responsibility**

3

Guidance is received following the quarterly review of results against planned regional contributions to the national contributions to the national program. Guidance on specific issues is received following the receipt of complaints. The work requires the evaluation of regional outputs against activities planned within the Feed and Fertilizer specialty. Recommendations are made on the feasibility of the planned regional contribution to the national activity. Advice is provided to the professional and technical staff and the industry in the Districts on the interpretation of policies, acts, regulations and guidelines and on approaches to correct problems.

**Management Responsibility**

2

Plans own work, uses facilities and occasionally assigns work to others. Coordinates activities with professional and technical departmental regional staff, industry associations, manufactures and other government departments.

**Impact of Recommendations and Activities**

3

Decisions affect the program delivery and the conduct of agricultural industries or businesses in two specialty areas (feed and fertilizer) within the region served by the position. Recommendations for corrective action and decisions on standards application affect the quality of goods produced. Recommendations are made to the Regional Program Manager on the suspension or cancellation of registrations or on the requirement to prosecute.

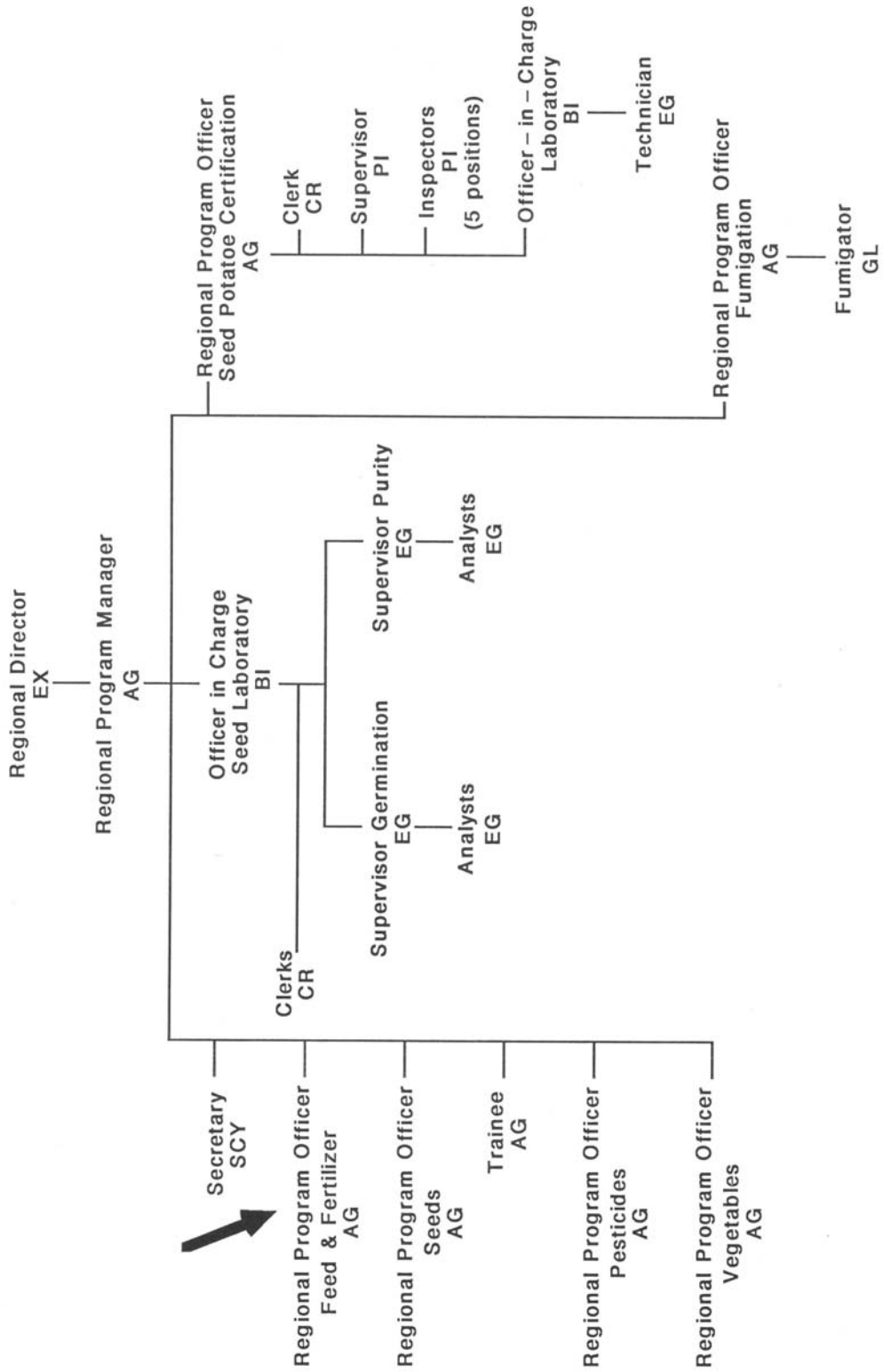

BENCH-MARK POSITION DESCRIPTION

Bench-mark Position Number: 5

Level: 4

Descriptive Title: District Manager, London

Reporting to the Regional Director, Ontario:

Plans, organizes, directs and controls the implementation of programs governing the production and processing of dairy, fruit and vegetable, livestock and poultry and plant products as well as ensuring the disease free status of a wide variety of plants and plant materials. Evaluates and monitors program activities in the district to ensure uniform application of quality standards and program delivery consistent with national and international agreements.

Evaluates and monitors program activities in the district to ensure uniformity of quality standards and program delivery. Evaluates quality standards recommendations proposed by the regulated agriculture industry. Appraises efficiency of field and laboratory work. Directs corrective action. Defines district objectives and guidelines. Establishes short- and long-term operational program goals and the requirements for financial and human resources. Makes recommendations on the formulation of regional and national multi-year operational plans. Establishes the priorities for inspection, special surveys, investigative and other activities. Reallocates resources within the district and ensures the implementation of procedures for the achievement of program goals. Ensures district program activities are coordinated with the activities of producers and provincial and other federal departments.

Manages and coordinates the work of district employees in several sub-district offices. Selects, trains and appraises staff. Designs organizational structure and recommends the classification of positions. Resolves staff relations problems and acts as the management respondent at the first step of the grievance procedure.

Monitors the progress of investigation and enforcement activities. Assesses potential cases for litigation and recommends action to the Regional Director. Advises subordinate on operational and managerial functions. Plans training programs to improve the performance of district staff, for example in the application of inspection standards, grade criteria and work management. Resolves more serious differences between district supervisors and senior agricultural industry representatives, producers and marketing boards.

Evaluates the content and recommendations of reports and special surveys. Assesses their impact on district crop and animal production and processing in terms of technological transfer, production, market availability and processing capacity for the Directorate's commodity inspection programs. Advises the regulated industry on processing techniques and equipment to improve plant efficiency and product quality.

Manages the transfer of new technological developments in the Directorate's commodity inspection programs to producers and industry representatives through the deployment of technical, professional and scientific specialists to resolve specific problems. Provides information to industry representatives on changes to departmental policies, programs and legislation.

Reviews and evaluates reports and proposals for program modification from subordinates and recommends modifications to inspection methods, procedures, program design and legislative requirements.

Works cooperatively with officials in other departments, other levels of government, foreign governments, producers, industry organizations as well as the import/export sector.

<u>Specifications</u>	<u>Degree/ Points</u>
<p><u>Kind of Assignments</u></p> <p>The work requires the definition of objectives for delivery of the district programs within the national and regional guidelines. The work involves a continuing district operation in several fields of specialty: livestock, poultry, dairy, fruit and vegetable, plant production and plant health and several program activities including inspection, enforcement, advisory, compensatory and economic development. A variety of administrative and scientific activities are required such as advising on financial, materiel and human resources required for district program implementation, controlling the inspection of the production and distribution of dairy, fruit and vegetable, livestock, poultry and plant products, and the assessment of the findings of special surveys. The work requires planning, integrating and organizing the district's inspection, investigation, advisory and special survey programs and the recommendation of amendments to regulations and legislation.</p>	4
<p><u>Complexity</u></p> <p>The work requires the selection and use of data which must be obtained through the development and investigation of sources in the district. Information relating to district programs is highly diverse and incompatible and often requires confirmation through long and short term recurring studies. The work also requires the resolution of problems between the provincial, foreign and other federal departments within the district and the producers and industry. Develops novel operational approaches to the delivery of several program activities in the District. The work requires knowledge of the principles, theories and practices of agricultural science and the technological advances in the related industries in the district.</p>	4
<p><u>Professional Responsibility</u></p> <p>Guidance is received from the Regional Director following the annual review of the goals and objectives concerning the nature of resources available and from the Regional Program Manager concerning the District's planned contribution to the defined regional programs. The work requires the evaluation of the conclusions of district staff. Recommendations are made on the approach and operational feasibility of the planned district's contribution to regional activity within several specialty areas. Advice is provided to the professional and technical staff and the agricultural industry in the London District on the interpretation of regulations, guidelines and methods affecting several specialties.</p>	4
<p><u>Management Responsibility</u></p> <p>Plans, controls and approves expenditures of funds and manages a large staff delivering several programs in the London District. Coordinates district activities within several program areas with departmental staff of regional programs, with industry associations and with foreign and other government departments.</p>	5

Degree/  
PointsImpact of Recommendations and Activities

4

Decisions and recommendations affect the conduct and delivery of programs and the economic development, initiation and continuation of agricultural industries or businesses in several specialty areas within the district managed by the position. Decisions on departmental resource allocation and work scheduling affect the commercial success of producers. Recommendations made within the Economic Regional Development Agreement (ERDA) committees affect the development of the agricultural industry in the district.

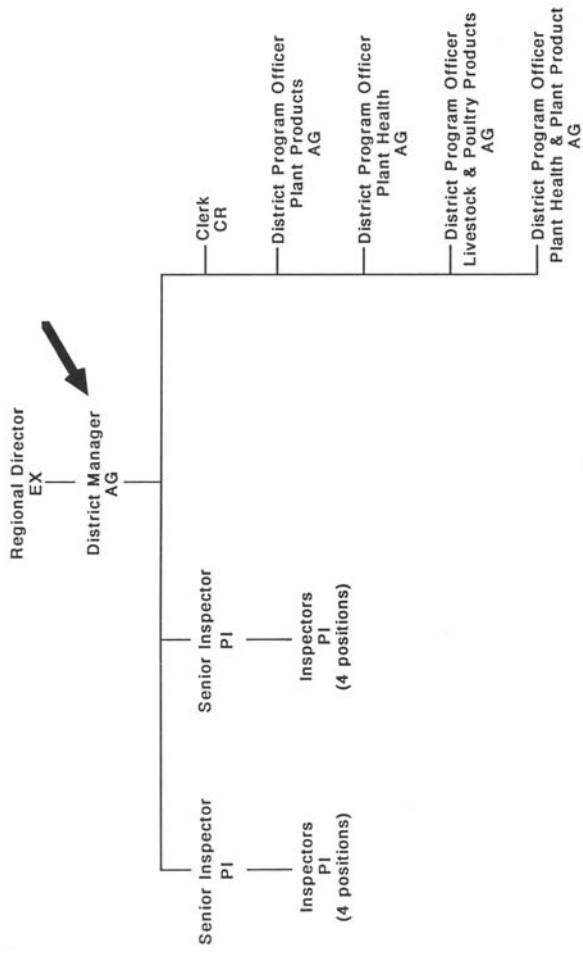

BENCH-MARK POSITION DESCRIPTION

Bench-mark Position Number: 6

Level: 5

Descriptive Title: Regional Program Manager  
Plant Health and Plant Products

Reporting to the Regional Director:

Plans and controls regional health and safety advisory and compliance programs including inspection, investigation, quality assurance and enforcement activities in the areas of seed, feed, fertilizers, pesticides and the phytosanitary inspection of plants, plant products and plant materials. Monitors regional inspection and laboratory outputs and reviews and evaluates program activities. Negotiates inter-district survey, investigation and inspection workloads for uniform application and compliance and special survey projects. Identifies program-related training needs and ensures training programs are delivered. Studies contentious issues and recommends solutions. Interprets departmental guidelines and procedures to staff, industry and other agencies, particularly in areas of ambiguous jurisdiction. Initiates and drafts new or revised operational and compliance policies, guidelines and procedures.

Develops the annual regional work plan. Evaluates regional analytical and inspection capability. Assesses trends in health and safety, technology, production, transportation, marketing and quality and phytosanitary control in the industry for plant products and plant health. Develops new or modified procedures and specifications for regional activities. Audits the quality of inspection and project activities. Designs projects and negotiates the districts' participation. Monitors, reviews and evaluates regional performance against targets and recommends strategy to correct deviations.

Negotiates work sharing agreements with officials of the Alberta government, universities and the industry, to facilitate cooperative work efforts and conduct projects to identify and control pests that are detrimental to agricultural crops, forests and horticultural plant species. Negotiates similar work sharing agreements with National Health and Welfare, Consumer and Corporate Affairs, Environment and other Branches of Agriculture.

Directs the investigation of violations of health and safety quality regulations and contractual standards. Sponsors the concerns of the producers, consumer and trade associations. Resolves serious regional disputes between industrial management and departmental staff in the plant health and plant products specialties.

Makes recommendations on major enforcement decisions which have serious socio-economic impact. Presides over hearings involving national or multinational companies operating in the region and recommends prosecution or decertification as appropriate.

Examines industry trends and practices, legal opinions, court rulings, interpretations and legislation. Recommends regulatory changes to correct legislative deficiencies and to ensure compatibility with provincial legislation and technological changes. Assesses the feasibility and impact of regulatory and advisory proposals on the region's programs.

Advises regional staff and management on new trends, technology, legislation and policies affecting programs. Informs and educates industry and other interested parties on plant products and plant health programs.

Works cooperatively with senior officials in own and other departments, other levels of government, foreign governments, educational institutions, industries, consumer organizations and professional associations.



Manages the Alberta Region Plant Products and Plant Health Section including person-years and salary, operating and capital funds. Defines the organization and the responsibilities of staff. Selects, trains, advises and appraises staff. Resolves problems related to work performance and discipline. Represents the Branch in the grievance procedure and at Union-Management meetings.

Degree/  
Points

### Specifications

#### Kind of Assignments

5

The work requires the definition of the objectives for the Alberta region plant products and plant health program within the national guidelines. The work involves a continuing regional operation in several fields of speciality: plant pathology, entomology and toxicology and intensive study of trends, practices and policies in plant products and plant health as well as the conduct of several studies in a variety of areas such as entomological (gypsy moth) and microbiological (golden nematode). A variety of administrative and scientific activities are required such as the performance evaluation of regional inspection programs, the provision of scientific and technical training and advice. The work requires planning and organizing the regional plant products plant health, inspection, monitoring, and advisory services and the recommendation of policies, programs and strategies to the national plant products plant health programs.

#### Complexity

5

The work requires the selection of data and information which is obtained from manuals, guidelines and regional industrial sources and scientific literature. Information relating to plant health and plant products require confirmation through special studies and critical analyses. The work also requires the arbitration of serious disputes on behalf of the staff with the industry and the general public concerning violations of quality regulations and jurisdictional disputes among federal departments. Develops new procedures and new approaches (for example deregulation) for the plant health and plant products programs in the region. The work requires knowledge of the principles, theories and practices of entomology and pathology and the practices and technological advances of the industry and their impact on national regulatory requirements.

#### Professional Responsibility

5

Guidance is received from the Regional Director following the annual review of the program goals concerning the nature of available resources and from the National Program Director concerning the Region's planned contribution to the National Program. The work requires the evaluation of the results of studies. Recommendations are made on the modification of current program activities or the creation of new plant product and plant health programs. Authoritative advice is provided to departmental staff and the national agricultural industry concerning the programs, policies, acts, regulations, guidelines for the plant products and plant health speciality.

#### Management Responsibility

4

Plans and controls the use of regional facilities and manages a professional staff and seed laboratory delivering the plant products and plant health program in the Alberta region. Coordinates regional activities in the plant products and plant health speciality area with departmental staff at headquarters and the region and with industry, national associations and provincial, foreign and other federal departments.

Degree/  
PointsImpact of Recommendations and Activities

4

Decisions affect the development, conduct and delivery of programs and the economic development, initiation and continuation of agricultural industries or businesses in the specialty areas plant health and plant products within the Alberta region managed by the position. Recommendations affect the definition of national policies for plant health and plant products. The conduct of show-cause hearings prior to suspensions or cancellations of certificates or registrations affect the continuation of economic activities in the region. Recommendations are made to headquarters on the cancellation of registrations.

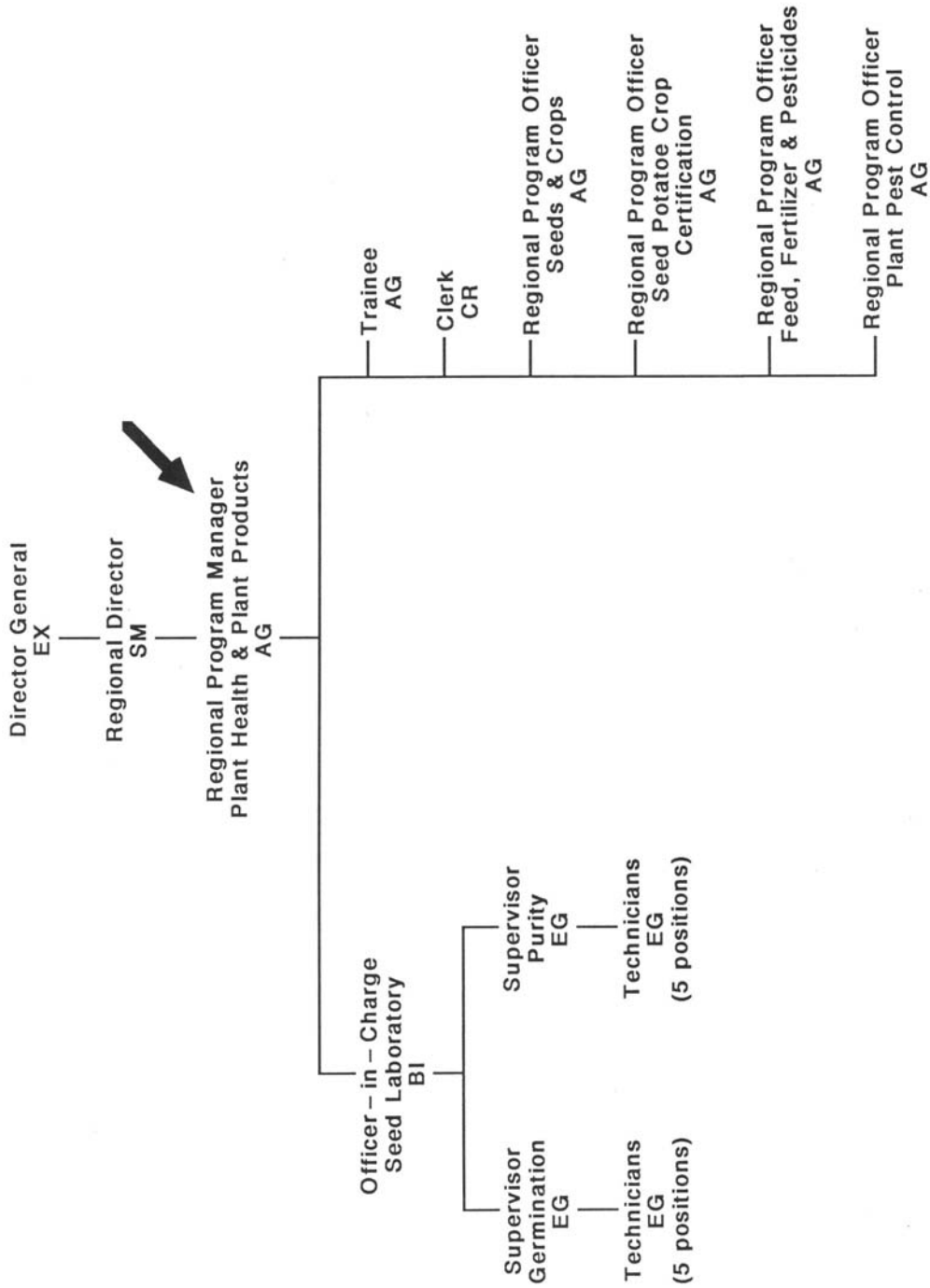

BENCH-MARK POSITION DESCRIPTION

Bench-mark Position Number: 7

Level: 5

Descriptive Title: Associate Director  
Dairy Products

Reporting to the Director, Dairy, Fruit and Vegetable Division:

Directs the developmental, technological, scientific, adjudicative and legislative activities for the planning, organizing, evaluating and auditing of the national dairy inspection programs (butter, cheese, yoghurt, ice cream, skim milk powder). Determines the objectives, priorities and specific goals for the regulation of the national dairy industry and the regulation of imported products. Evaluates the progress of the program and the compliance status of the regulated industry. Recommends resource allocation to meet program requirements.

Develops quality control and review and audit programs to ensure the reliability and uniformity of inspection and analytical data across Canada. Defines analytical and inspection quality control objectives for all regions. Identifies the need for effectiveness studies in laboratory, inspection and advisory activities and identifies work quality objectives for regional laboratory operations. Evaluates regional program performance and recommends corrective action.

Directs the development of new strategies for national and international programs of dairy inspection and labelling control of food - borne disease. Directs the improvement and delivery of joint federal - provincial dairy inspection programs and regulatory controls for the protection of Canadian consumers.

Assesses, evaluates and determines, in conjunction with senior officials of National Health and Welfare the acceptability, operational and technical feasibility, cost effectiveness and impact of proposed health modification to the Food and Drugs Regulations as it relates to dairy products, the industry and the food inspection program.

Directs the implementation of food safety research related to dairy products and the development of national policies for health and export standards. Contributes to the elaboration of international norms/codes for example to the Codex Alimentarius.

Evaluates the effectiveness of legislation, policies, regulations and programs related to the enforcement of the Canadian Agricultural Products Standards Act. Directs the development of and improvements to the legislation, such as changes to the Canada Dairy Products Act and the Dairy Products Regulations. Decides on contentious enforcement, certification and registration cases.

Works cooperatively with Health and Welfare Canada, Fisheries Canada, Consumer and Corporate Affairs and Regional Industrial Expansion, Canadian Dairy Commission and provincial departments to minimize regulatory gaps and overlaps and to review new regulations on food inspection. Ensures the regulation of the import/export movement of dairy products and the review of production and processing facilities and inspection systems of foreign countries. Consults and negotiates with foreign officials to minimize non-tariff trade barriers. Negotiates the provision of uniform inspection services with the provincial governments. Promotes the maintenance of a federal - provincial inspection system to meet the requirements of foreign countries for export purposes.

Participates in government - consumer and government - industry consultative committees on food safety, standards, grades and technological innovations for example the status of analogue foods such as imitation cheeses. Represents the department as Director on the Board of the National Dairy Federation, the Canadian Dairy Commission and Dairy Farmers of Canada. Promotes Dairy Products programs and policies to the regulated industry and the international market. Advises senior departmental and ministerial staff, the industry and the general public on the national dairy inspection program.

Manages the Dairy Products Division including person-years and salary and operating funds. Selects, trains, advises and appraises staff.

Degree/  
Points

### Specifications

#### Kind of Assignments

5

The work requires the definition of national policies and program objectives, for the dairy products specialty. The work involves the national program in one field of specialty - dairy products, and intensive study of trends, policies and programs in Canadian and foreign dairy industries and markets. A variety of administrative and scientific activities are required such as the operational evaluation of programs and legislation, and national and international inspection, grading and health and safety regulations. The work requires planning and organizing the National Dairy Plant Registration, Laboratory, Production, Inspection, Grading, Legislation and Labelling, Education and Regulatory Programs.

#### Complexity

5

The work requires the selection of data from foreign and domestic sources and the assembly and evaluation of data obtained through intensive studies and investigations. Information generated by surveys relating to dairy products must be analyzed and validated prior to use. The work also requires the resolution of problems between government agencies, and the agricultural industry both domestic and foreign. Develops novel strategies to enhance the dairy industry in Canada. The work requires knowledge of the theories and principles of dairy science and of agricultural practices relating to food production and marketing nationally and internationally.

#### Professional Responsibility

5

Guidance is received from the Director following the annual review of the national dairy program delivery against national objectives, concerning the mandate of the national dairy program. The work requires the evaluation of the results of studies. Recommendations are made on the modification of current program activities or the creation of new dairy products programs. Authoritative advice is provided to departmental staff and to the national and international dairy industry concerning several subjects including health and safety standards, inspection services and the development of Canadian regulations.

Degree/  
PointsManagement Responsibility

4

Plans and controls the organization, evaluation and audit of the national dairy inspection program and recommends the expenditure of operational and research funds for the dairy products program. Manages a professional staff delivering the national dairy products specialty area with departmental regional staff, with national associations and international regulating bodies and with foreign and other government departments. Coordinates the development of Canada-wide standards to the requirements of foreign regulatory agencies.

Impact of Recommendations and Activities

5

Decisions and recommendations affect the development, initiation and conduct of national and international programs and the economic development, initiation and continuation of national agriculture and food industries or businesses in one specialty area: dairy products. Decisions on policies, regulations and standards affect the operating costs associated with the national industry. Recommendations to international codex standards impact on the import/export dairy market. Final decisions on deregistration of businesses affect the termination/continuation of individual economic activity nationally.

