

Student  
**Activity**  
Kit

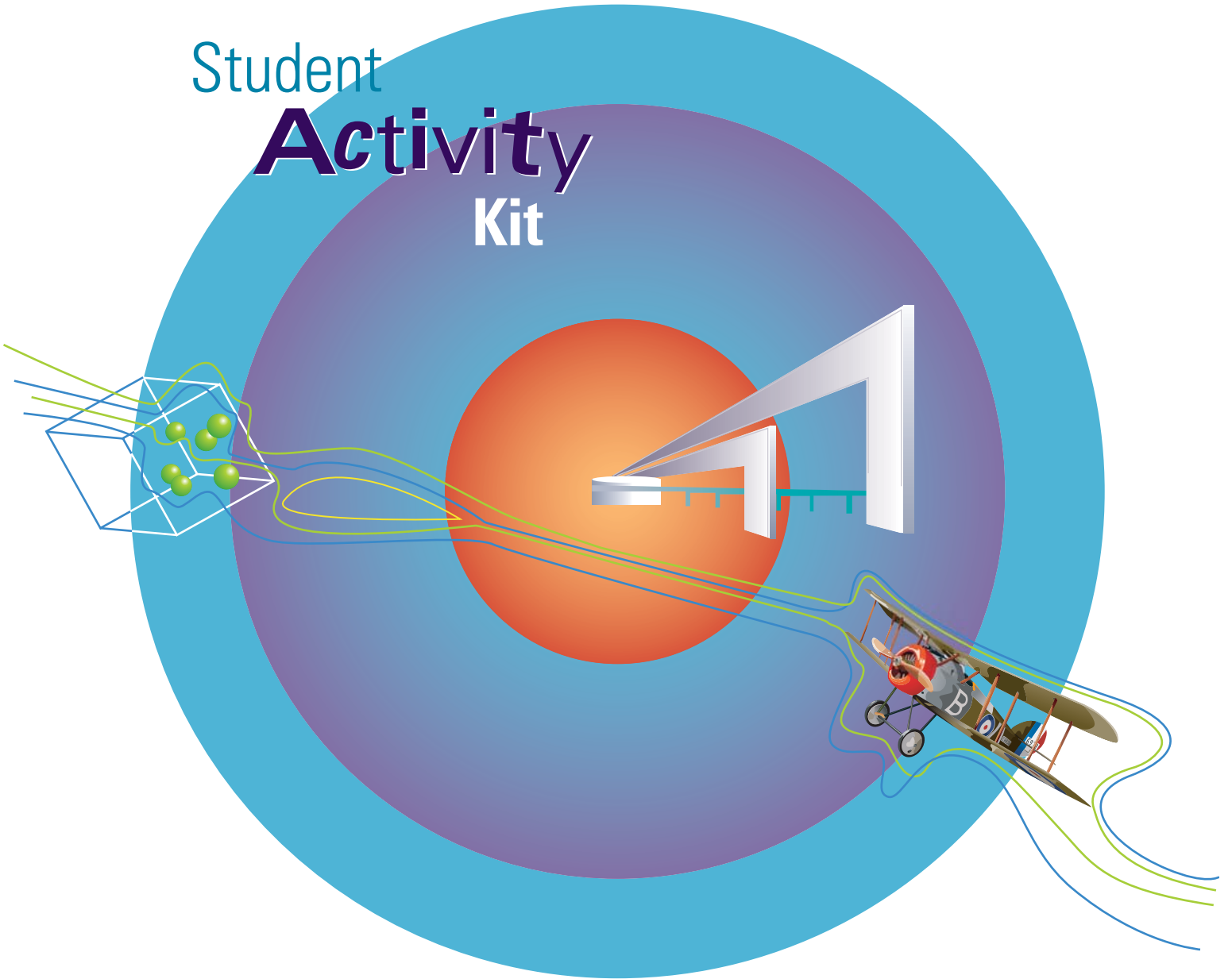

We are pleased to offer you the enclosed ***Student Activity Kit*** for ages 4 and up. For information on our school programs revisit our Web site at [www.aviation.nmstc.ca](http://www.aviation.nmstc.ca) or call us at **1-800-463-2038**.

The Canada Aviation Museum is grateful to the Federal Aviation Administration (US) for their permission to adapt some of their activities.



## To Start

Make two photocopies, on thick paper, of both sheets illustrating sixteen aircraft of the Museum's collection (see appendix) and cut out the 32 cards.

## How to Play

This is a memory and association game. You have 32 cards facing down. The objective of the game is to associate two cards with the name and drawing of a same aircraft (they are aircraft in the Museum's collection).

Each participant must, one after the other, flip two cards. If the two cards correspond to the same aircraft, the participant scores a point. If the drawings on the two cards do not correspond to the same aircraft, the cards are flipped face down again. The next participant then tries to do the same.

The following consists of historical information regarding the 16 aircraft found on the cards.

### de Havilland D.H. 60X Moth

The romance with powered flight is really starting to take off in Canada during the mid 1920s. Suddenly, there is wide demand for an aircraft that is affordable, reliable, easy to fly and easy to maintain. The de Havilland Moth flies in to fill that need. The Moth quickly becomes the airplane known for "putting the fly in flying". With its reliable engine, superb controls, and efficient air frame, the Moth is economical and highly manoeuvrable. During the late



1920s and early 1930s, the pilots flying Moths spread the word of aviation throughout Canada. At air shows and special events, Moths approach from the horizon and for many Canadian of the era, it is the first aircraft they've seen.

### Canadair Sabre 6

In the mid 1950s, Royal Canadian Air Force (RCAF) pilots helping to keep the peace in Europe



become the envied elite flying force of the West. The reason: their Canadian-built Canadair Sabre fighters powered by the Canadian Orenda jet engine. The Sabre is the first swept-wing fighter built in North America, and quickly gains a reputation as "a pilot's plane". A single-seater, the highly manoeuvrable Sabre is the first fighter that can routinely exceed the speed of sound in a dive. Though it represents a giant step forward in military aviation, it still has one foot in the past. For unlike all other advanced fighters that follow it, the Sabre is still a manual aircraft. Early Sabres had a successful career at war—tipping the balance against the Russian-built MiG 15 during the Korean War—and on peacekeeping missions around the globe.

### McDowall Monoplane

It is 1910, and Robert McDowall, a municipal engineer from Owen Sound, Ontario, is vacationing with his wife in Paris. The couple decide to visit a Parisian display, and it is there that McDowall falls in love again—this time with aviation, for



on display is the famous Blériot XI, which in 1909 became the first airplane to cross the English Channel. Back in Owen Sound, McDowall's second love gets the best of him, and he sets to work on his own version of the Blériot. But alas, man cannot fly on love alone, and despite its builder's dedicated efforts, the McDowall Monoplane never truly flies. Though its design is not aerodynamically sound, the McDowall Monoplane nevertheless does represent the pioneer spirit and ingenuity that sustained the early development of aviation. And after being restored by the Canada Aviation Museum in 1987, it finally claimed its rightful place as the only surviving Canadian pioneer aircraft.

### Messerschmitt Me 163B-1a Komet

In 1944 the Allies have clearly gained an upper hand in the war with Germany. But the Germans have yet another secret weapon up their sleeve—the Messerschmitt Me 163B-1a Komet. The Komet is a short-range rocket-powered interceptor designed to blast off high into the sky and intercept incoming Allied bombers. The Komet is very fast, enabling it to launch lightning attacks on Allied planes. Trailing a long rocket exhaust tail, it stuns and surprises Allied airmen. But in the end, the highly advanced Komet is a dangerous aircraft to operate and it claims more German than Allied pilots—built by enforced labour, the Komet is the victim of frequent sabotage. In



fact, a small, sharp stone placed under the highly volatile fuel tank of the Komet at the Canada Aviation Museum is clear evidence of the sabotage that threatened the aircraft.

### Avro Canada CF-105 Arrow

The explosion of the first Soviet atomic bomb, in September 1949, sends shockwaves throughout the Western world. That same year, preliminary design studies for a supersonic bomber interceptor begin in Avro Canada's design office. In April 1953, the Royal Canadian Air Force (RCAF) submits a specification for an extremely powerful and superbly equipped twin-engine two-seat aircraft. Avro Canada's proposal is accepted. The Arrow is born. The first aircraft is presented to the public in October 1957. On the same day, the USSR launches the world's first artificial satellite, Sputnik I, an event that will have serious consequences for the future of the CF-105. The Arrow flies for the first time in March 1958 but, already, costs are soaring. In September, a newly elected government terminates its fire control system and missile. In February 1959, the entire project comes to a end. In the ensuing furore, the government is harshly criticized. Even today, the entire affair retains an almost mythical status. Few Arrow artifacts have survived and the Canada Aviation Museum is fortunate in that it has a forward fuselage, two wingtips, an Iroquois engine and other components.



## de Havilland Canada Beaver

In the mid 1940s, de Havilland Canada is wondering what features Canadian bush pilots want most in a new aircraft. So the company undertakes one of the first comprehensive market research surveys. The resulting aircraft—the Beaver—quickly becomes a testament to the importance of research and development. The Beaver's ability to adapt to any type of landing gear, its power and manoeuvrability, and its "short takeoff and landing" (STOL) capabilities, quickly make it a favourite on every continent of the world. During the Korean War, it becomes known as the "General's Jeep", because it is the chosen craft of commanding officers travelling from one combat zone to the next. As the generals find out, it can outperform the helicopter in every category except straight vertical lift. In civil service, the Beaver becomes a renowned bush plane, and many continue in service today. The Beaver was chosen in 1987 by the Engineering Centennial Board as one of the country's outstanding engineering achievements.

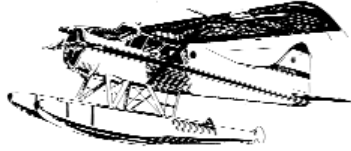

## SPAD VII

As World War I enters its third year, the German-built Albatros is having a field day with the less-advanced aircraft of the Allies. But France has had enough, and so along with Britain, begins production of the superior French-designed SPAD VII. With aces like Canada's A.D. Carter at the controls, the SPAD VII helps reassert



Allied control over the skies. But immediately following the war, there are other plans in store for the SPAD VII that today is on display at the Canada Aviation Museum in Ottawa. After serving a stint in the U.S. Army, the SPAD VII stars in "Wings", the very first film to win an Academy Award.

## Supermarine Spitfire L.F. Mk. IX

It's July, 1942. For almost a year now, the Germans have enjoyed aerial



combat supremacy with their sleek Focke Wulf 190 fighters. In response, the Allies have designed an improved version of the legendary Supermarine Spitfire, the Mk IX. The new Spitfires roll off the assembly line and streak off the runway in rapid succession. With its more powerful engine, the new Spitfire can hit speeds upwards of 650 km/h. In all areas of combat performance, the Mk IX meets or beats the Fw190. The balance is restored. The Supermarine Spitfire and the men who flew her are legends.

## Bell HTL-6

As the 1950s get under way, the helicopter is becoming increasingly visible in North America.

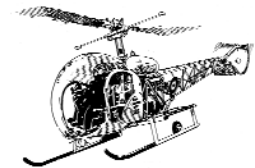

One of the organizations intrigued by its potential is the Royal Canadian Navy (RCN). For its first helicopter, the RCN chooses a proven American design, the Bell Model 47, first flown in 1945 and the first helicopter to be commercially licensed, in 1946. After an incredible career on every

continent, with more than 6 400 Model 47s built by Bell and its licensees in Italy, Japan and the United Kingdom, production ends around 1977. The RCN acquires half a dozen HTLs, the U.S. Navy designation of the Model 47. However, most Model 47s in use in Canada today are civilian. The Museum's HTL-6 flew with the RCN between 1955 and 1966, when it was retired to the Canada Aviation Museum. It served in many roles over the years, including ship-based survey work along Canada's coasts and in the Arctic.

## Boeing 247D

In the early 1930's, commercial air travel is already starting to attract people away from railway service. But being an air passenger leaves a lot to be desired. The planes are uncomfortable, not very reliable, and afford only rudimentary onboard service. Then along comes the Boeing Corporation to the rescue. Boeing's 247 is the first modern airliner, capable of flying coast to coast in just 19 3/4 hours, and able to climb on a single engine with a full load. It is an all-metal, stressed-skin, cantilever monoplane with retractable undercarriage, air conditioning, a working galley, onboard toilet—even flight attendants. Demand for the 247's advanced features leads Boeing competitor Douglas Aircraft to design and build the celebrated DC-2 and DC-3, which incorporate all of the 247's innovations and more.



## A.E.A Silver Dart

It's February 23, 1909. On the ice of Nova Scotia's Bras d'Or Lake, a small crowd has gathered to watch the Silver Dart prepare for flight. At the controls is J.A.D. McCurdy, designer of the Silver Dart, and a Canadian. The engine stutters, the balloon fabric wings flutter, the craft skims along the ice. As skaters race to keep up with her, the Silver Dart lifts off and flies half a mile. Below, the crowd on the lake has witnessed history in the making. The Silver Dart is the first powered heavier-than-air aircraft to fly in Canada. A full-scale airworthy replica of the Silver Dart which flew at Bras d'Or Lake on February 23, 1959, is on display at the Canada Aviation Museum in Ottawa.

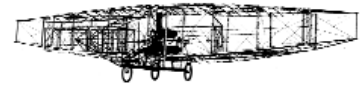

## Curtiss HS-2L

World War I is over, and flight is about to make its first real impact on Canadian civilian life. Of all the aircraft build for the Allies during the conflict, it is a Curtiss HS-2L—an American-built anti-submarine "flying boat"—that makes its way into the country aviation lore. Donated by the United States to the Canadian government after the war, La Vigilance—the Curtiss HS-2L on display at Canada Aviation Museum—makes the first long-distance flight in Canada, from Halifax to Grand Mère, Québec, in 1919. At the controls is Stewart Graham. His wife,



Madge Graham, accompanies him on the flight, and that makes her the first woman to make a long distance cross-country flight in Canada. La Vigilance becomes the first commercial aircraft entered on the Canadian Civil Register and makes the first bush flight in Canada. In 1922, while on a commercial flight for Laurentide Air Services, La Vigilance crashes on takeoff from a lake near Kapuskasing, Ontario, where it remains until it is raised by a crew from the Canada Aviation Museum. Over a 10-year period, the Museum's staff lovingly restores La Vigilance, making it the only surviving Curtiss HS-2L in the world.

## de Havilland Canada Dash 7

It is the mid-1970s, and the demand for efficient business air travel has never been greater. The de Havilland Company of Canada thinks it has one of the answers: the world's first real "short takeoff and landing" (STOL) airliner, capable of providing efficient and convenient service between smaller downtown airports. That airliner—the Dash 7—is hailed as a marvel of Canadian aviation engineering. Combining and improving on the best features of the de Havilland Canada's successful Beaver, Otter, and Buffalo, the Dash 7 does everything asked of it: it is fast, quiet, able to drop into and fly out of small airports located close to major downtown areas. While many Dash 7's enter service and continue to perform beyond expectations even to this day, de Havilland eventually stops production, because the anticipated development of

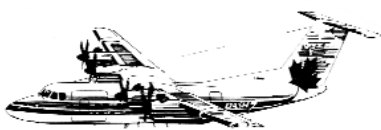

downtown airports doesn't materialize and the Dash 7's STOL characteristics make it more expensive to operate on normal routes than conventional airliners. The first Dash 7 to roll off the de Havilland Canada production line is on display at the Canada Aviation Museum in Ottawa.

## Curtiss JN-4 Canuck

World War I is raging and it's the cause of a lot of "firsts" the world over. In Canada, the war demands the manufacture of the country's first mass-produced aircraft—the Curtiss JN-4 Canuck. Developed from the American Curtiss JN-3, the Canuck is built by Canadian Aeroplanes Ltd., which becomes recognized as the most efficient aircraft manufacturer in North America during the war. Over 1 200 Canucks are built in Canada during 1917. Production peaks at 30 aircrafts a week, and Canada becomes a leader in flight training for Allied pilots. When the U.S. enters the war in 1917, it buys hundreds of Canucks from Canada, making the aircraft the country's first major export aircraft. Following the war, the Canuck becomes the first aircraft to carry air mail in Canada, the first to cross the Rockies, the first to be used for aerial surveying, and the first aircraft seen in many parts of Canada. The Museum Curtiss JN-4 (Can.) is one of those Canucks sold to the Americans that was recovered from a barn in upstate New-York in 1965 to become the Museum's first major restoration project.



## Aircraft of the Collection

### Stearman 4EM Senior Speedmail

It's the early 1930's, and a few of the pilots in Canada's fledgling air mail service are feeling the envy of their colleagues. It's not because they've been given better routes to fly. Nor is it because they're making more money. It's because those lucky few have been assigned to fly new Stearman 4EM's. The Stearman can outperform just about any aircraft flying in Canada, military or otherwise. It's fast, with a top speed of close to 250 km/h, and even when carrying a full load of mail, the aircraft is a pleasure to fly.



### Avro Lancaster X

The Second World War is raging. In the dark of night, an RCAF Lancaster bomber is flying a mission over Germany. The target is spotted below. The bomb bay's massive doors swing open, and the heaviest load carried by any bomber during the war plummets groundward. Suddenly, the Lancaster is ripped by enemy shells. With part of its tail section missing, the Lancaster is damaged, but not destroyed. It manages to return to base in Britain, like so many durable Lancasters, its mission accomplished. The Lancasters were the backbone of the Allies' Bomber Command.



## The Walkway of Time: Highlights in the History of Canadian Aviation

As visitors enter the Canada Aviation Museum, they are greeted by an extraordinary, near life-size, bronze sculpture. With the body of a man and two pairs of bird's wings, the creature is stretching its wings into the wind, poised for takeoff.

The Falcon was created in 1932 in the classical style of the Renaissance as a tribute to modern aviation by renowned Canadian sculptor, surgeon, and physical educator, Robert Tait McKenzie. It is a powerful depiction of humanity's age-old yearning to fly.

While The Falcon stands in the foyer representing humanity's longing to escape the bounds of earth, the aeronautical collection inside the Museum proper tells the other side of the story — the final realization of the dream of flight in the twentieth century's development of powered, heavier-than-air flying machines.

The aircraft and exhibits in the Canada Aviation Museum are arranged chronologically to guide a visitor along a "Walkway of Time" that traces the history of aviation and highlights Canada's pioneering contributions.

The visual effect of the exhibits is quite spectacular, with the original and often bright markings of the aircraft standing out against the stark white and gray background of the Museum interior, as they would on a snowy northern airfield or frozen lake.

The aircraft are clustered in pools or islands of time, with each island representing a key period

in aviation history. Visitors can view the entire collection from the second floor mezzanine. On the main level they can follow aviation history step-by-step from its beginnings to the present day. The journey back in time begins with the pioneer period.

## Early Flying Machines

The first aircraft visitors encounter is the Silver Dart, Canada's first successful heavier-than-air flying machine.

The story of the Silver Dart began in 1907, when the world-famous inventor of the telephone, Dr Alexander Graham Bell, and four promising young men interested in aviation formed the Aerial Experiment Association (A.E.A.). Bell had previously performed aerodynamic experiments with kites, but he was already in his sixtieth year, past the age for experimenting aboard untested and frail flying machines.

The younger members of the A.E.A. included Glenn Curtiss, an American designer of internal combustion engines; Lieutenant Thomas Selfridge of the U.S. Army; and two Canadians, John A. D. McCurdy and Frederick W. "Casey" Baldwin, both recent engineering graduates from the University of Toronto.

The A.E.A.'s purpose was an ambitious one — no less than the construction of a "practical aerodrome or flying machine driven through the air by its own power and carrying a man." The association operated alternately out of Hammondsport, New York, where Curtiss had a machine shop, and Bell's estate at Baddeck, a tiny Maritime village on Cape Breton Island, Nova Scotia.





## Aviation in Canada

The A.E.A. was extremely successful, building and flying four airplanes in rapid succession. The last of these was the Silver Dart, designed by John McCurdy and considered one of the more advanced airplanes of its day. On 23 February 1909, McCurdy made the first airplane flight in Canada in the Silver Dart, taking off from the ice of Baddeck Bay and flying for about 800 metres. Mabel Bell shares with us her account of this historic achievement: "Everyone came. School was left out and the children brought their skates. When the Silver Dart lifted off the ice they cheered and tossed hats and mittens into the air. After John landed we invited everyone in for sandwiches, tea and coffee, and Alex's favourite drink, raspberry vinegar."

After forty-six successful flights in the Silver Dart, some covering distances as great as 32 kilometres, McCurdy and Baldwin attempted to raise funds for further experiments by demonstrating the airplane before military authorities at Camp Petawawa, Ontario, on 2 August 1909. Unfortunately, on the landing of the fourth flight of the day, the Silver Dart flipped over and was smashed beyond repair.

On February 23, 1959, exactly fifty years after the first historic flight, a replica of the Silver Dart built by the Royal Canadian Air Force (RCAF), was flown by Wing Commander Paul Hartman at Baddeck Bay with John McCurdy in attendance. This is the aircraft on exhibit in the Museum.

Many other Canadians tried their hand at building and flying airplanes before the First World War. But the Museum's only original airplane from Canadian aviation's pioneer period – in

fact, the only surviving Canadian aircraft from this period anywhere – is the McDowall Monoplane. Built by Robert McDowall, a municipal engineer from Owen Sound in Ontario, it completed a few "hops," but never flew successfully. Nevertheless, it remains a fascinating example of the efforts of early aviation enthusiasts.

After the crash at Petawawa, McCurdy, Baldwin, and even Bell himself made repeated appeals to the government in Ottawa for financial support for aviation. But to no avail. Canada went into the First World War without an air service, and our main contributions were the provision of men and the manufacture of training aircraft.

### **Flying for the Allies in the First World War**

On 4 August 1914 Britain declared war on Germany. Canada, as part of the great British Empire, was at war, a war in which the airplane changed forever the way nations do battle.

The war brought new words to the aviation dictionary, among them: "dogfight," "ace," "bomber," "air raid."

At first the airmen's main job was reconnaissance. They brought back "bird's-eye views" of the enemy and later photographs. The pilots didn't want enclosed cockpits. They would have ruined the view and hampered the use of their first weapons – hand-held rifles, pistols, bricks and even grappling hooks! These were soon replaced by mounted machine guns.



## Aviation in Canada

The French SPAD VII is one of the classic single-seat fighters – the wire, wood and fabric "Top Gun" of its time. Rugged and solid with good performance it was flown by the French, British, American, Belgian, Italian and Russian air forces.

The French called pilots of great skill and daring "aces." During the War, "ace" gained its present meaning: a pilot who has downed five or more enemy aircraft in combat. Pilots like Bishop, Ball, Guynemer, Rickenbaker, Baracca and the famous Red Baron, von Richthofen.

Canada entered the war with a handful of airmen. By 1918 there were 22 000. A third of the pilots in the British air services who downed thirty or more enemy aircraft were Canadians. Our image of First World War aviators is one of flamboyant gallantry, but the truth is that hundreds of young men died horrible deaths in their flying machines. Some 1 563 gave their lives, and well over half that number were decorated, three with the Victoria Cross — W. A. "Billy" Bishop, A. A. McLeod, and W. G. Barker. Of seven British pilots credited with 50 or more victories, four were Canadians, including the Empire's two leading surviving aces — Bishop with seventy-two victories, and Raymond Collishaw with sixty.

The Museum's Curtiss JN-4 (Can.) Canuck is one of 1 288 machines produced by Canadian Aeroplanes Ltd of Toronto, a company established by the Imperial Munitions Board to meet the RFC and later the US Air Service's requirement for training aircraft. The Canuck, a modified American Curtiss JN-3, holds more firsts than any other Canadian aircraft. It was the first

aircraft to be mass produced in Canada and first to be exported in large quantities. It flew the first Canadian air mail in June 1918 between Montreal and Toronto, and made the first aerial survey, in Labrador, in the summer of 1919. After the war, it entered into widespread civil use, where it became the preferred airplane of barnstormers, giving many Canadians their first sight of an aircraft and their first chance to fly.

### **Bush Flying in the 1920s and 1930s**

During the First World War, Canadians acquired skills as aircraft mechanics, designers, builders, and pilots. Over 2 000 returnees were trained combat pilots. The desire of some of these people to carry on in aviation provided a springboard for the development first of bush flying and later of Canadian commercial airline services in the years between the wars.

In 1919 most of Canada's north was unexplored country. Flyers in aircraft like the ones on display in the Museum's Bush Flying island put the wilderness on the map. They were essential to the discovery and development of our natural resources. They made this country into a vast community linked by highways in the sky. The hair-raising experiences of Canada's bush flyers in some of the most inhospitable wilderness territory on earth have become legendary.

These were years of record-breaking flights — Alcock and Brown flew non-stop across the Atlantic and Lindbergh made his famous solo crossing aboard the Spirit of Saint Louis. In

Canada we met the challenge of distance inside our borders. Flying boats like the HS-2L gave us access to thousands of ready-made airports – our lakes and rivers.

One of the Museum's proudest acquisitions is *La Vigilance*, a Curtiss HS-2L flying boat. HS-2Ls flew coastal patrols from France, the United States, and Canada during the First World War. After the war, the Canadian forest industry began to consider the uses of aircraft in forestry patrol work. *La Vigilance* was one of two surplus HS-2Ls acquired by the St. Maurice Forest Protective Association for spotting bush fires, mapping, and transporting firefighters and their equipment. In 1919, *La Vigilance* performed the world's first commercial bush flight in the St. Maurice Valley north of Trois-Rivières, Quebec.

In 1969, the Museum managed to salvage *La Vigilance* from the bottom of an unnamed lake near Kapuskasing, Ontario, where it had crashed on takeoff in 1922. Painstakingly restored using parts from two other HS-2Ls in addition to those from *La Vigilance*, it is on display in the Museum – the only surviving HS-2L in the world.

During the 1920s and 1930s, many small bush flying companies operated right across the country. They carried people, equipment and supplies primarily for the natural resources industries, delivered the mail and performed aerial surveying and mapping. In 1934 Canada set the world record for freight carried – mail and machines, eggs and dynamite, cows and canoes, medicine and furniture. You name it, they flew it.

## Growth of the Airlines

As the small bush companies grew, they became the precursors of Canada's modern airlines. Western Canada Airways, formed by Winnipeg businessman James A. Richardson in 1926, eventually became Canadian Pacific Airlines and more recently Canadian Airlines International. In 1937, the Canadian government established Trans-Canada Air Lines (TCA), now known as Air Canada, to provide transcontinental air transport service in this country.

The Museum's collection includes a Boeing 247D. This aircraft was the world's first modern airliner. All the most up-to-date developments of the day were put into this machine. The prototype flew in 1933. It combined greater comfort and safety with much improved cruising range and speed. Advertised as the Club Car of the air it provided the comfort of sound-proofing, air-conditioning, reading lamps and, with a flight attendant for ten passengers, all the care and attention you could want. It had an automatic pilot, could fly safely on one engine and had retractable landing gear. The 247D made all other airliners obsolete. It even flew faster than the military aircraft of its time.

The Lockheed 10A Electra was Trans-Canada Air Lines' first new airplane delivered in 1937. TCA, now called Air Canada, started up in 1937 with two second-hand Electras and a Stearman Model 4 mailplane. When regular TCA passenger service began in 1939, the travelers welcomed by the stewardess at the bottom of the ramp were in expert hands. That year 1 000 young women applied for twelve flight attendant positions. Pat Eccleston, one of

TCA's first attendants: "To be a stewardess in those days you had to be a registered nurse. Many passengers were nervous about flying and the company needed people who were trained to talk to strangers and make them feel at ease. You had to be aged 21 to 25, female and single. The minute you got married you lost your job. Because the cabins were so small you couldn't be over 5 foot 5 inches (1.65 metres)."

The luxury, performance, and safety improvements, plus a bigger passenger cabin, were incorporated into the Douglas DC transport, culminating in 1936 with the appearance of the Douglas DC-3, one of aviation's all-time greats. The first transport that could operate at a profit without subsidies, the remarkable DC-3 became the backbone of commercial airliners around the world. The aircraft on display is, appropriately, TCA's first DC-3. Acquired by the airline in 1945, it flew for thirty-eight years before Goodyear Canada donated it to the Museum.

## Canada in the Second World War: "Aerodrome of Democracy"

One cluster of airplanes stands out boldly from all the others in the Museum collection. Their bright yellow color identifies these machines as training aircraft used in the British Commonwealth Air Training Plan (BCATP). The plan produced airfields all across Canada and helped create a modern, mass-production aircraft industry in this country. All BCATP trainers in the Museum—the Harvard, the Anson, the Tiger Moth, and the Finch—were built in Canada.

As in the First World War, however, Canada entered the Second World War ill-prepared to fight an air war. The Royal Canadian Air Force (RCAF) had only 270 aircraft on hand, almost all of them outdated. But Canadians responded to the challenge with overwhelming generosity. By the end of the war, Canada had produced over 16 000 operational and training aircraft.

The huge Avro Lancaster bomber is particularly significant to Canadians. It was the most successful heavy night bomber of the Second World War. The "Lanc" Mk. X is one of about 450 built in Canada and ferried to the Royal Air Force's Bomber Command in Britain. After checking out an early Canadian-built Mk. X, one British inspector told his staff to look it over if they wanted to see how an aircraft should be built.

Night fighters and anti-aircraft fire took a deadly toll especially when bombers flew their own route to target before the development of bomber streams, when up to 1 000 aircraft flew in organized formations. However, Lancs could take incredible punishment. Many made it back to base riddled with bullets, with gaping holes in their sides and even parts of their wing and tail sections missing.

The Hawker Hurricane was without a doubt the most important aircraft in the Battle of Britain of 1940. Since the war, the Spitfire's glory has overshadowed the vital role of the Hurricane in this great strategic air battle, even though 85 percent of the victories were accredited to the Hurricane.

More Hurricanes were built than Spitfires. The Hurricane was simpler to build, could take more punishment and be repaired more quickly—of vital importance in the three-and-a-half month battle when the Royal Air Force would lose 915 aircraft. During the war, 1 400 Hurricanes were built in Canada under the direction of Canadian Car and Foundry's chief engineer Elsie MacGill. Seven RCAF squadrons flew Hurricanes beginning in that crucial July of 1940.

## Canadian Aviation in the Jet Age

Immediately after the war, commercial aviation mushroomed. From nine million passengers worldwide in 1945, the number climbed to 24 million in 1948. The widespread introduction of jet transport beginning in the late 1950s created a revolution in speed, comfort, and efficiency similar to that of the first modern airliners in the 1930s.

Most Canadians are aware that, for a brief period before the program's cancellation in 1959, the supersonic Avro Canada CF-105 Arrow interceptor made this country a world leader in jet fighter aircraft. Few Canadians know, however, that Canada had established similar leadership in jet airliners, with the Avro Canada C-102 Jetliner.

When it took off for the first time on 10 August 1949, the Jetliner was the first jet transport to fly in North America; it was only two weeks behind the first in the world, the British de Havilland Comet. Within a few flights, the Jetliner exceeded 800 km/h whereas the most advanced transports of the day achieved about 450 km/h.

However, with the advent of the Korean War, the Canadian government ordered Avro Canada to concentrate on production of the CF-100 interceptor. The Jetliner never entered mass production. The prototype made its last flight in November 1956, after which it was cut up and sold for scrap.

The Museum tells the bittersweet story of postwar jet design and manufacture in Canada with an exhibit that includes the only remaining major parts of the Arrow and the Jetliner—nose sections from each.

The CF-100, first flown in January 1950, met a happier fate. The only one of Avro Canada's jets to reach production, it was considered the best all-weather fighter of its day and was used by the RCAF and the Canadian Armed Forces until the last one was retired in 1981.

The Korean War was the first time jet fighters met in combat. In the air, it was essentially a duel between the American F-86 Sabre and the Soviet MiG-15. They both have the swept-wing design developed from German research during the Second World War.

Although the MiG was in some ways superior, the final score in Korea was 800 MiGs lost, 78 Sabres lost. Pilot training and experience made the difference. Unlike the North Koreans, many of the allied pilots were Second World War veterans.

The outstanding success of the Canadian aviation industry in the postwar period is the Beaver, first flown in 1947. The Beaver is also the precursor of de Havilland Canada's advanced short takeoff and landing (STOL) aircraft such as the Dash 7.



## Aviation in Canada

Many innovations found in the Beaver were based on the answers to a questionnaire de Havilland Canada sent to bush operators across the country. The result? The best small utility aircraft in the world! Its all-metal structure was a first for Canadian-designed bush aircraft. Its effective wing and flap design gave it excellent STOL performance. The floor hatch and wide doors handled rolled-in fuel drums and bulky cargo, saving time and money.

Eventually, the Beaver became the most numerous of all Canadian-designed aircraft with 1 691 manufactured. Hundreds of Beavers are still flying more than fifty years after the first one took off. The Museum's specimen is, appropriately, the prototype Beaver, acquired in 1980 after almost thirty-three years of rugged flying.

### Conclusion

The Canada Aviation Museum is of special significance to this country and its people. Aviation has profoundly influenced the lives of Canadians and holds a special place in their hearts.

Since Canadians began the world's first commercial bush flying operations shortly after the First World War, aircraft have played a critical role in opening up this vast, rugged, and sparsely populated land. Perhaps no other nation on earth has relied as heavily as Canada on aviation. The aircraft, artifacts, and exhibits in the Canada Aviation Museum attest to this fact.

But the juxtaposition of the aircraft from the Silver Dart to modern jets also tell a more fundamental and universal story. The astonishing successes and noble failures of aviation have been achieved by individuals responding to the powerful allure of flight. Because of their insatiable desire to participate in this great adventure, they propelled aviation from the halting experiments of the pioneers to the sophistication of the jet age.



## Vocabulary

**aerodynamics:** the study of forces of air acting on objects in motion relative to air.

**ailerons:** moving parts, attached to the rear edge of an airplane's wings, that help the airplane roll (or bank) left to right.

**air:** a mixture of gases making up the atmosphere which surrounds the earth.

**airfoil:** a streamlined surface designed in such a way that air flowing around it produces lift.

**airplane:** an engine-driven, fixed-wing, heavier-than-air aircraft.

**airship:** a long cigar-shaped aircraft filled with gas that is lighter than air, propelled by an engine, and steerable. Also called a dirigible.

**altimeter:** an instrument for measuring in feet or in meters the height of the airplane above sea level.

**altitude:** the vertical distance from a given level (sea level) to an airplane in flight.

**anemometer:** an instrument that measures the speed of wind.

**atmosphere:** the blanket of air surrounding the earth.

**balloon:** a bag filled with gas or a mixture of gases, that is lighter than air, propelled by the wind, and non-steerable.

**barometer:** an instrument to measure the pressure of the atmosphere.

**biplane:** an airplane with two sets of wings, one wing above the other.

**blimp:** a small dirigible that is lighter than air, propelled by an engine, and steerable.

**cockpit:** the place the pilot sits to fly the airplane. It contains the instruments and controls.

**compass:** an instrument used by pilots to determine direction.

**drag:** the force that slows down an airplane as it flies through the air.

**elevators:** the moving horizontal parts of the tail on an airplane that move up and down to make the airplane climb or descend, or pitch.

**engine:** the part of the plane that provides power, or propulsion, to pull or push the airplane through the air.

**flaps:** the moving parts attached to the rear edge of an airplane's wings that are used to increase lift and drag at reduced airspeeds (take-off and landing).

**force:** a push or a pull exerted on an object.

**fuselage:** the streamlined body of an airplane to which are fastened the wings and tail.

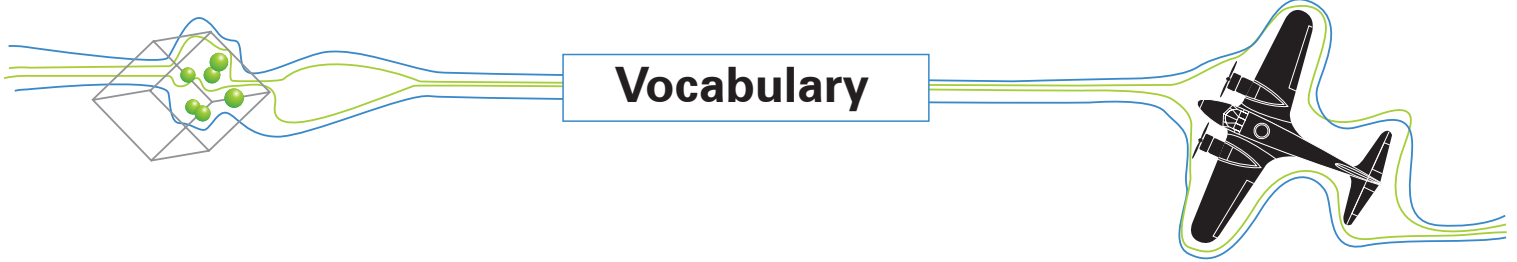

## Vocabulary

**landing gear:** the under structure (wheels, skis or pontoons ) of an airplane which supports it on land or water. Retractable gear folds up into the airplane in flight. A fixed gear does not retract or fold up.

**glider:** an airplane without an engine.

**gravity:** the force which pulls toward the center of the earth.

**lift:** the upward force caused by the rush of air around the wings, supporting the airplane in lift.

**lighter-than-air:** aircraft that is lifted into the air by a gas that weighs less than air.

**pressure:** a measure of force over a given area.

**propeller:** two or more twisted blades which an engine turns which pull an airplane forward as they turn.

**rudder:** the moving vertical part of the tail that controls the left to right, or yaw movement of an airplane's nose.

**streamline:** the shape of an object which causes air to flow smoothly around it.

**supersonic:** faster than the speed of sound (332 m/s (1195.2 km/h) at 0°C).

**tachometer:** an instrument which measures the speed at which the engine crankshaft is turning in revolutions per minutes (RPM).

**thrust:** the force of the engine which drives an airplane forward.

**turbulence:** irregular motion of air; uneven currents of air.

**wing:** the part of an airplane shaped like an airfoil and designed in such a way as to provide lift when air flows around it.



# Connect the Dots



Connect the dots from 1 to 63.

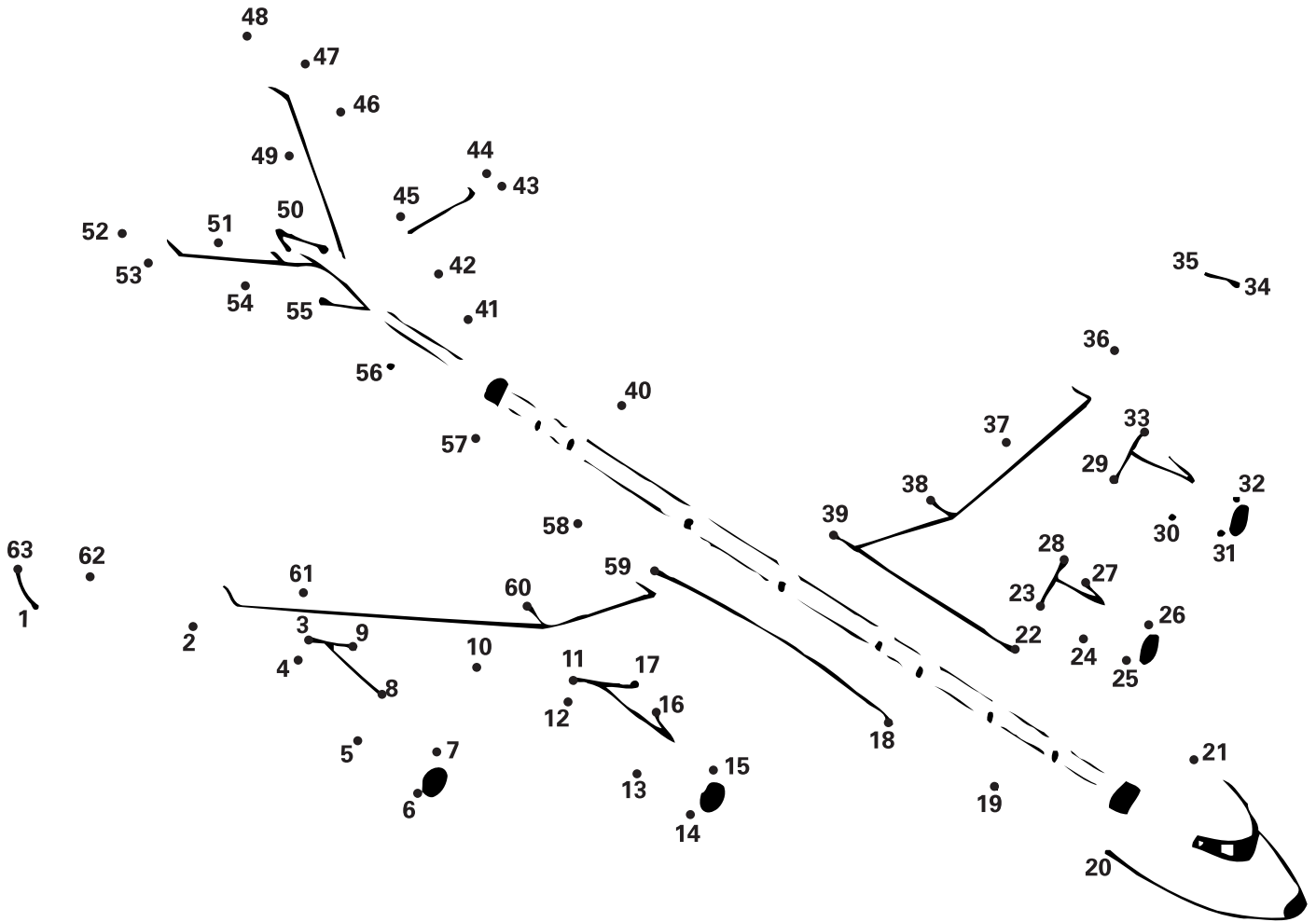

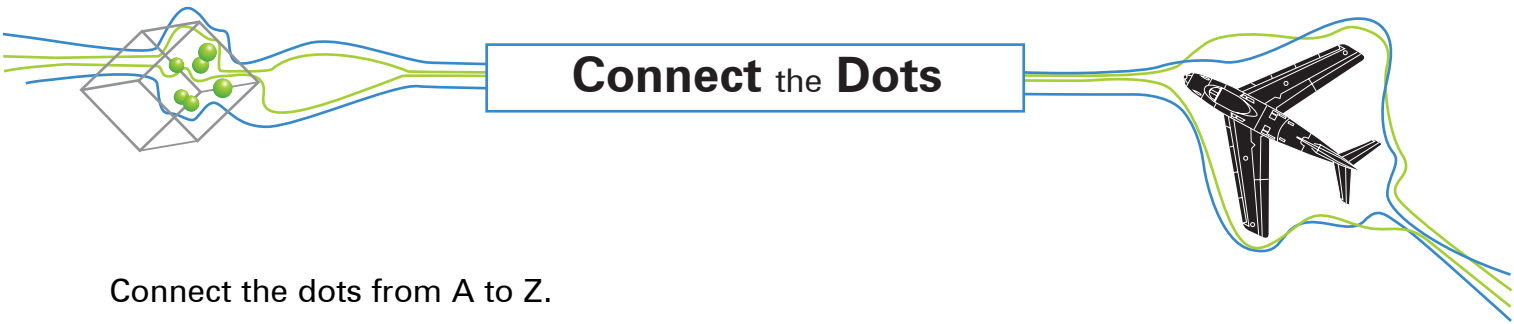

# Connect the Dots

Connect the dots from A to Z.

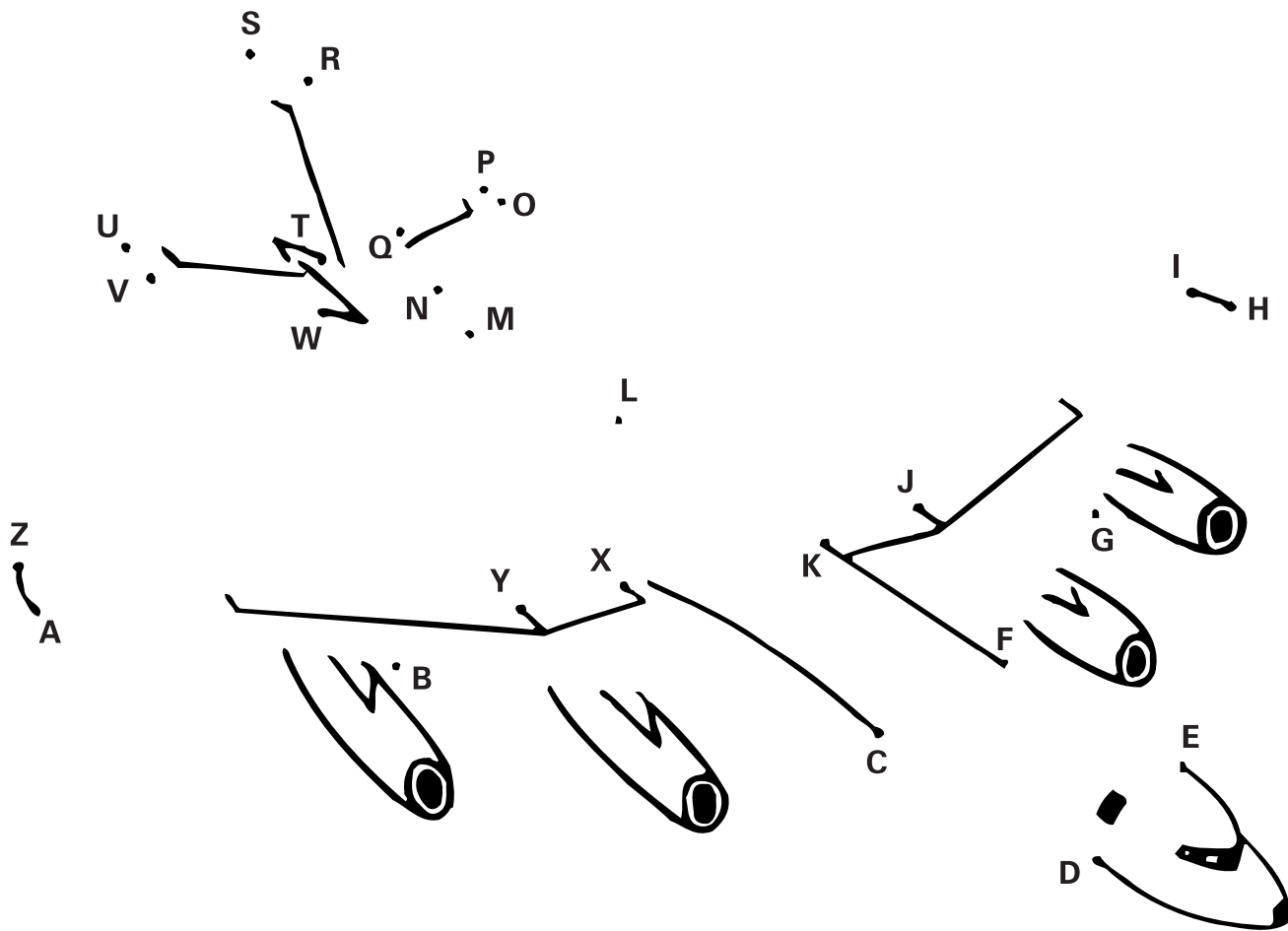



## The **Main Parts** of an **Airplane**

Discuss the following words.

**fuselage**

**cockpit**

**landing gear**

**wings**

**flaps**

**propeller**

**ailerons**

**elevator**

**rudder**

Label each part.

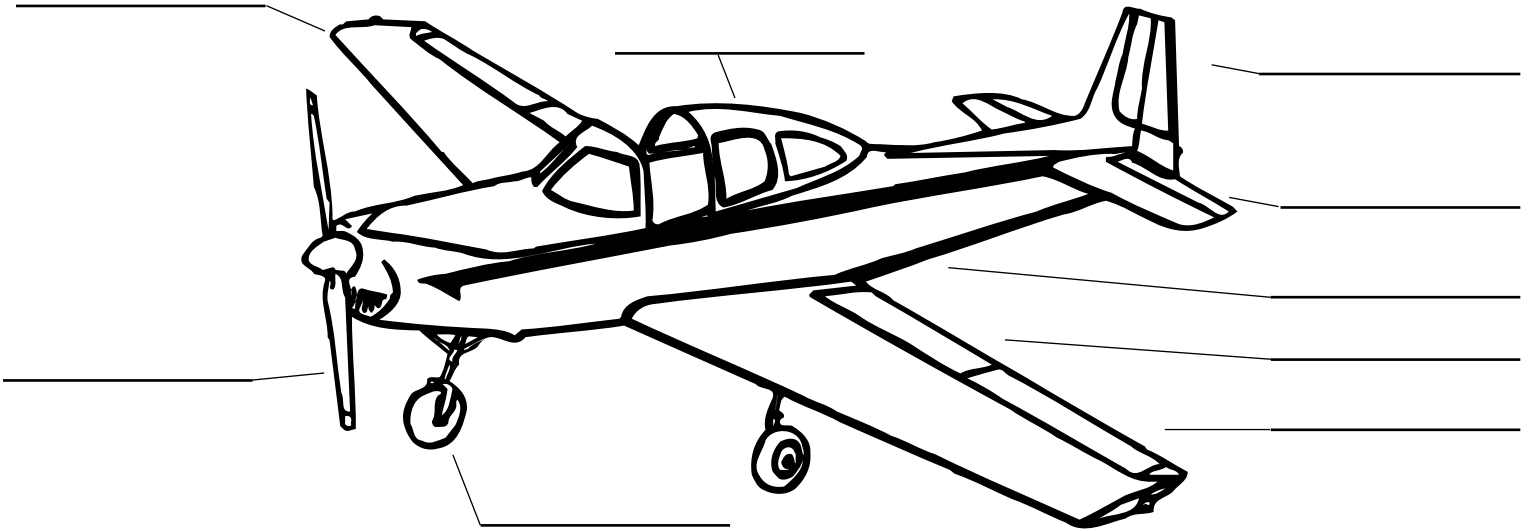



## The **Main Parts** of an **Airplane**



- Colour the flaps yellow.
- Colour the fuselage red.
- Colour the landing gear purple.
- Colour the propeller orange.
- Colour the ailerons black.
- Colour the elevators green.
- Colour the rudder blue.
- Colour the wings brown.

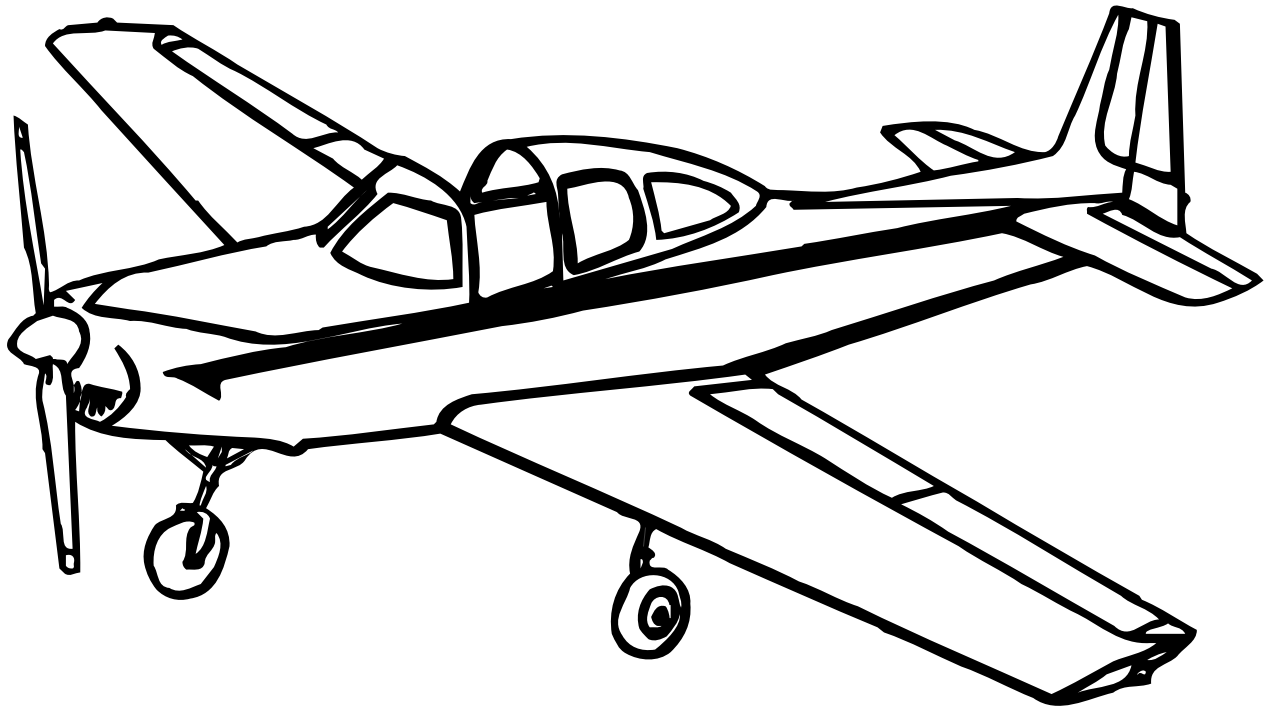

# The Main Parts of an Airplane

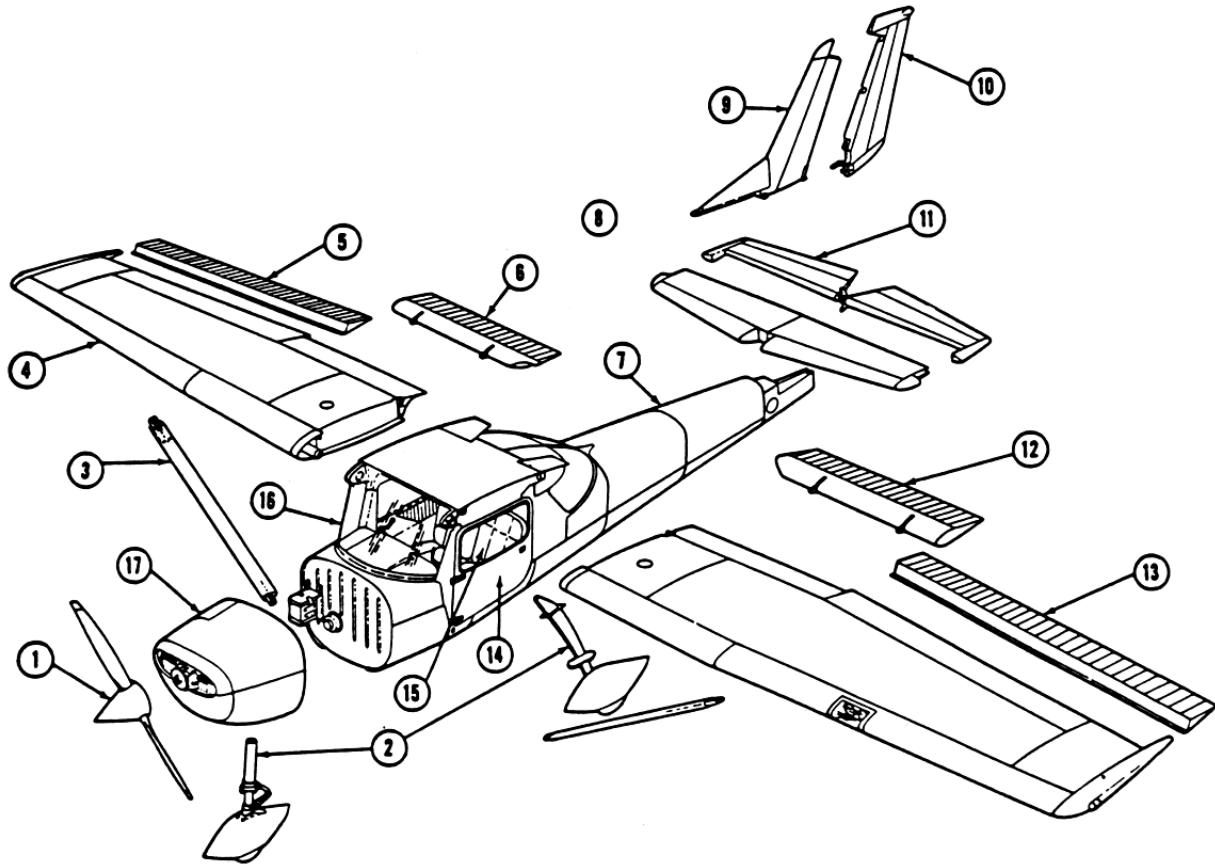

1. \_\_\_\_\_
2. \_\_\_\_\_
3. \_\_\_\_\_
4. \_\_\_\_\_
5. \_\_\_\_\_
6. \_\_\_\_\_
7. \_\_\_\_\_
8. \_\_\_\_\_
9. \_\_\_\_\_

10. \_\_\_\_\_
11. \_\_\_\_\_
12. \_\_\_\_\_
13. \_\_\_\_\_
14. \_\_\_\_\_
15. \_\_\_\_\_
16. \_\_\_\_\_
17. \_\_\_\_\_

# The Main Parts of an Airplane

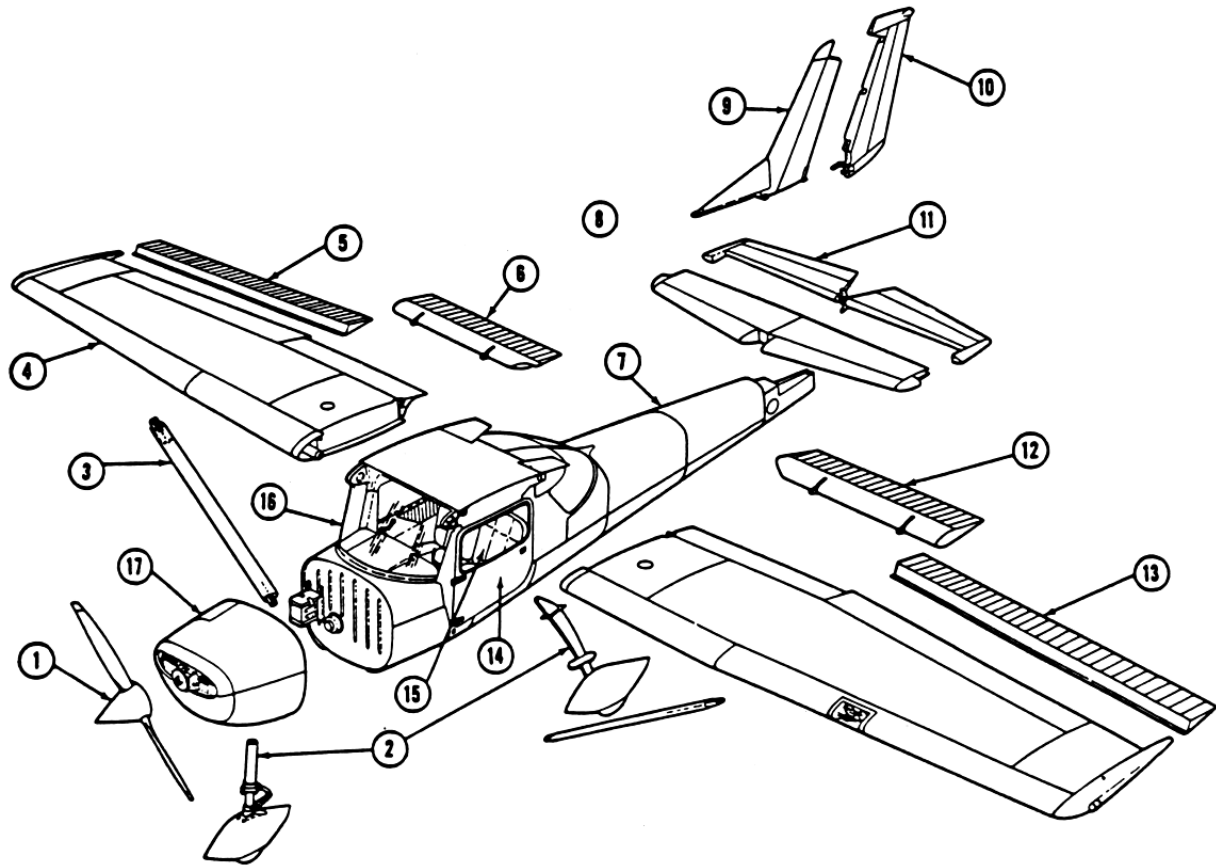

- |                          |                       |
|--------------------------|-----------------------|
| 1. Propeller             | 10. Rudder            |
| 2. Landing Gear          | 11. Elevator          |
| 3. Wing Strut            | 12. Left Wing Flap    |
| 4. Wing                  | 13. Left Wing Aileron |
| 5. Right Wing Aileron    | 14. Door              |
| 6. Right Wing Flap       | 15. Seat              |
| 7. Fuselage              | 16. Windshield        |
| 8. Horizontal Stabilizer | 17. Engine Cowl       |
| 9. Fin                   |                       |



## Parts that Control Airplane Movement



Colour the rudder blue.  
Colour the ailerons red.  
Colour the elevators green.

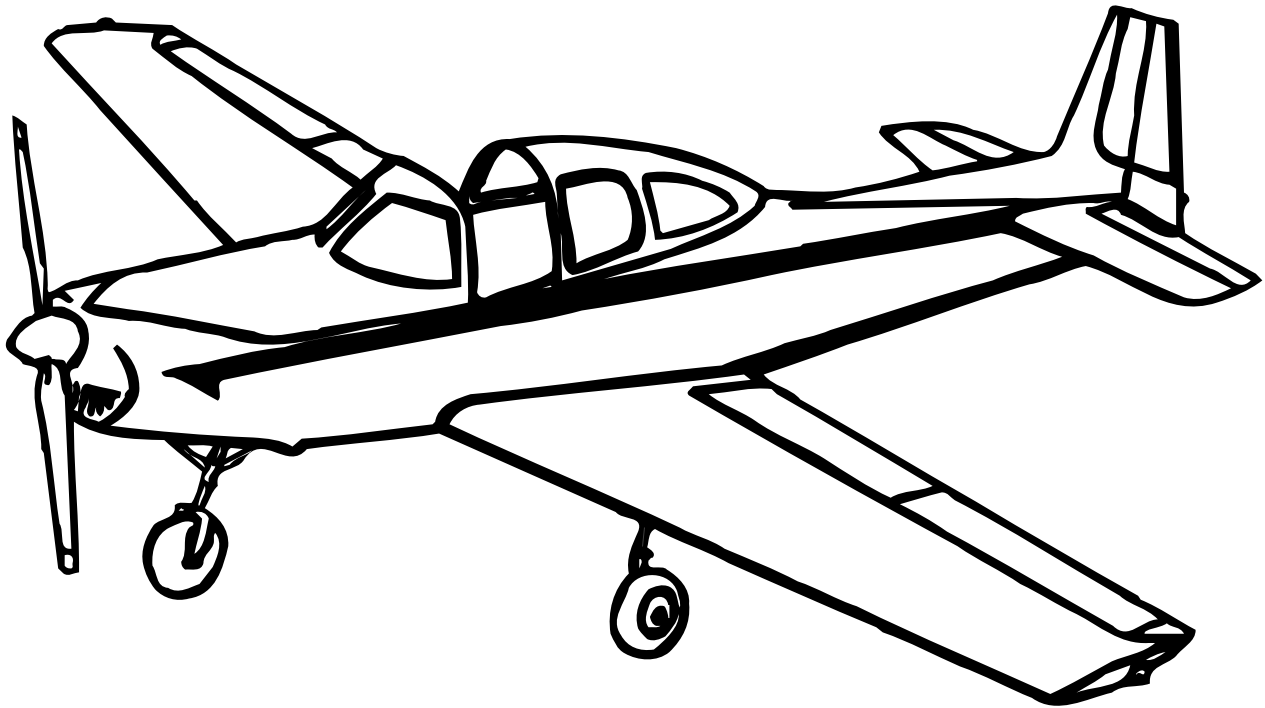

Fill in the blanks.

The \_\_\_\_\_ make the airplane climb and descend.

The \_\_\_\_\_ make the airplane roll left or right.

The \_\_\_\_\_ makes the airplane turn left or right.

# The **Four Forces** of Flight

Discuss the following terms.

Drag - Lift - Thrust - Weight

Fill in the blank with the appropriate term. Label the airplane.

A \_\_\_\_\_ is the force caused by the rush of air around the wings, supporting the airplane in flight.

B \_\_\_\_\_ is the force of the engine that drives an airplane forward.

C \_\_\_\_\_ is the force that pulls an aircraft towards the centre of the earth.

D \_\_\_\_\_ is the force that slows down an airplane as it flies through the air.

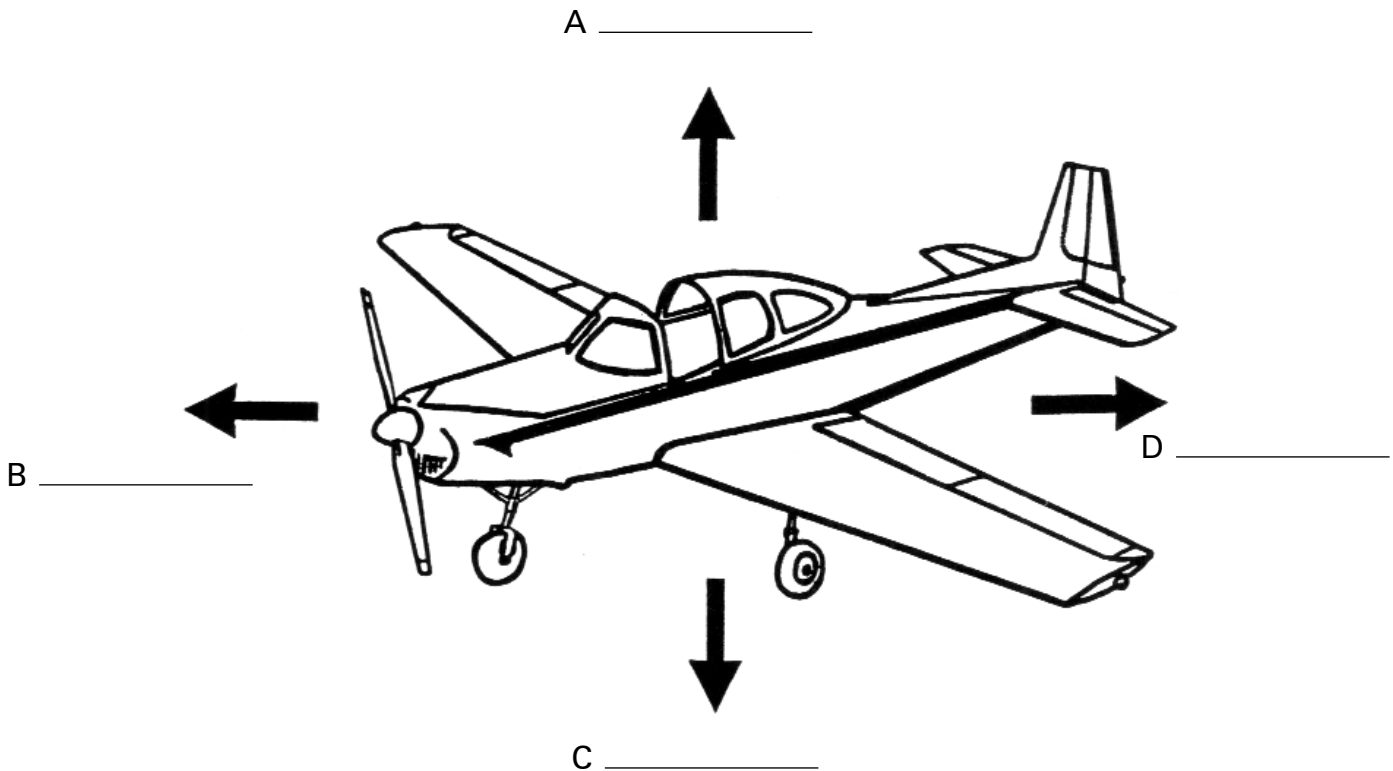





The Memory Game.



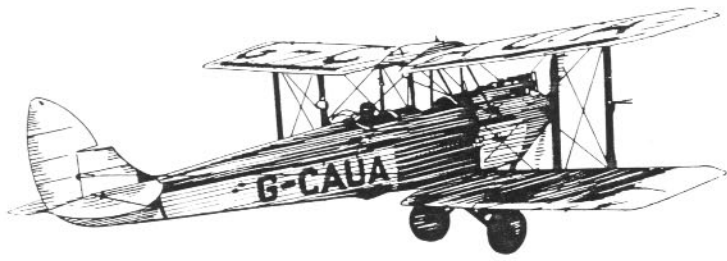

de Havilland D.H. 60X Moth

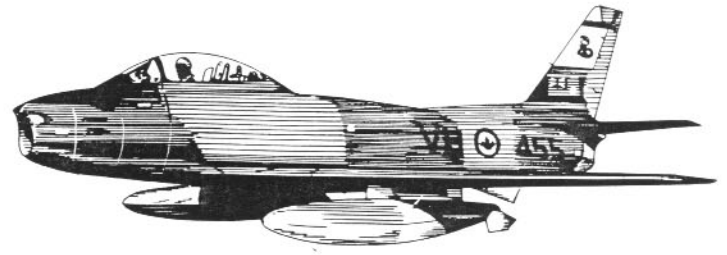

Canadair Sabre 6

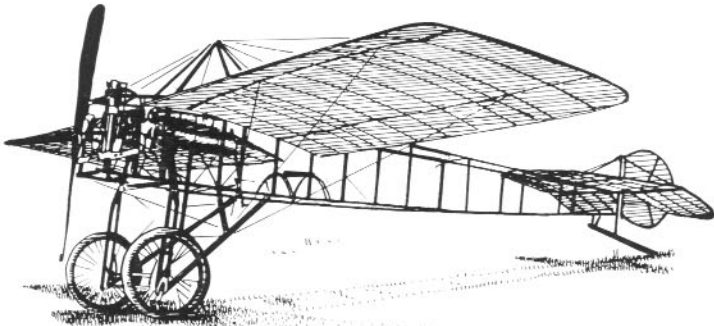

McDowall Monoplane

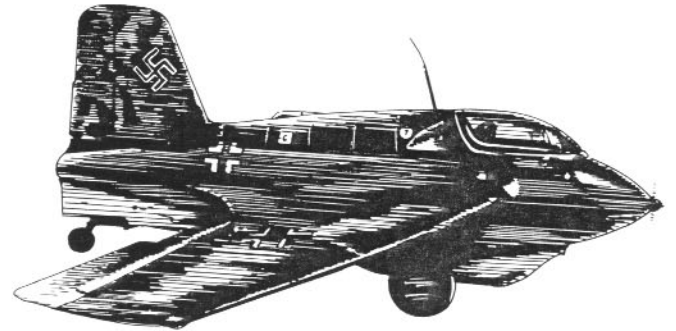

Messerschmitt Me  
163B-1a Komet

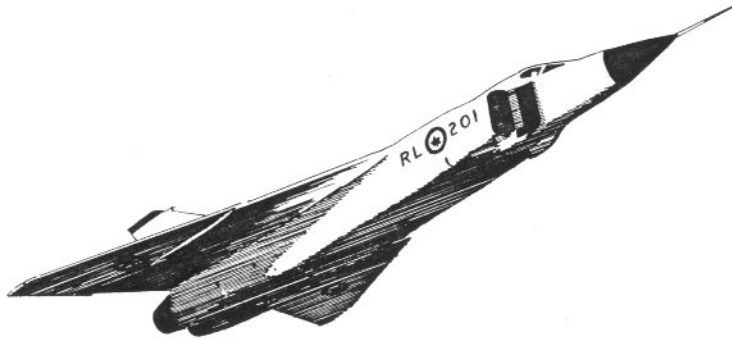

Avro Canada CF-105 Arrow

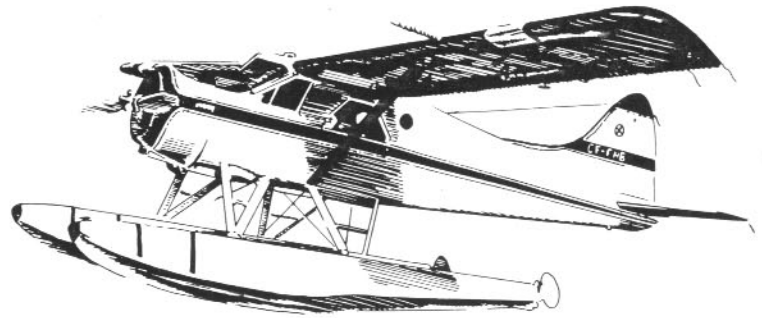

de Havilland Canada Beaver

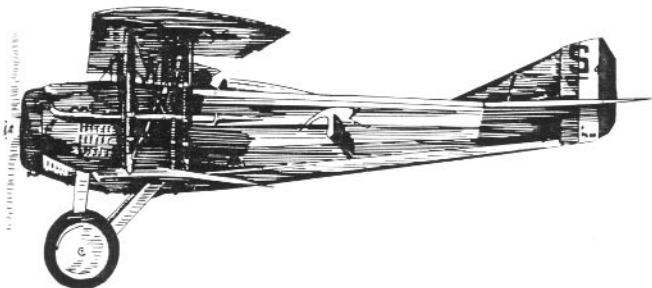

SPAD VII

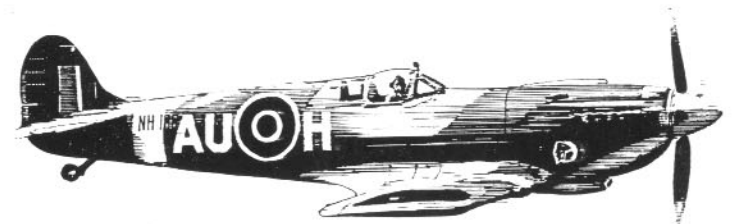

Supermarine Spitfire L.F. Mk. IX

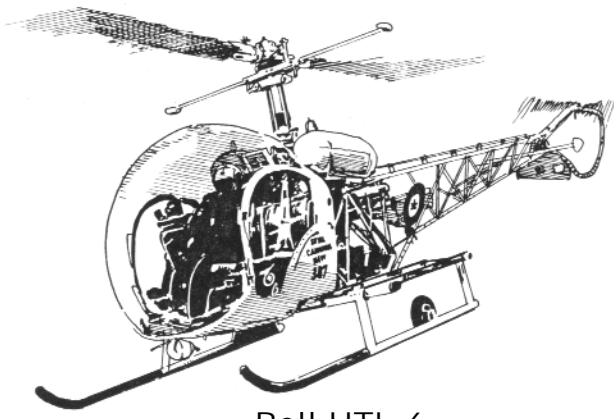

Bell HTL-6

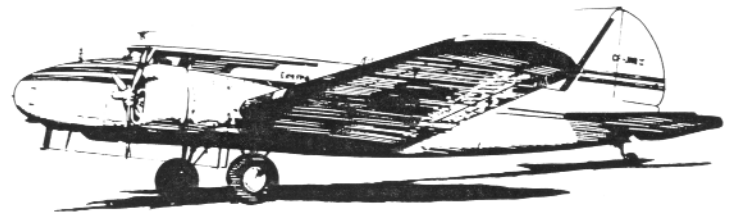

Boeing 247D

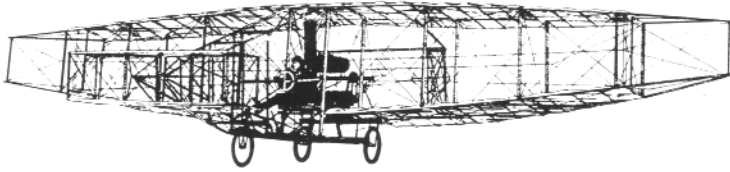

A.E.A. Silver Dart

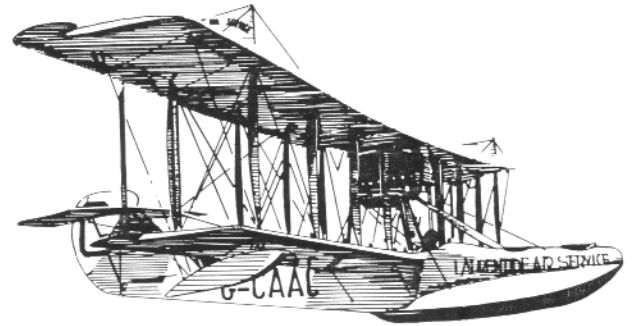

Curtiss HS-2L

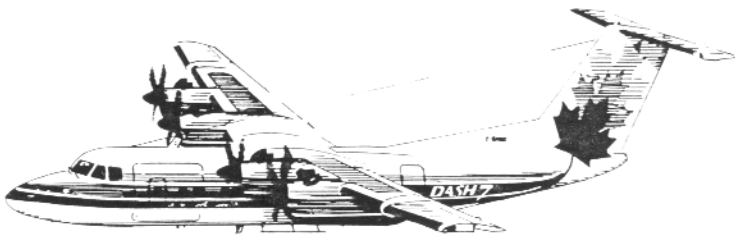

de Havilland Canada Dash 7

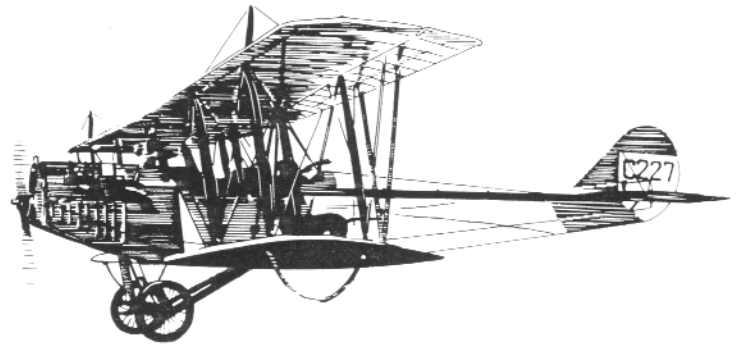

Curtiss JN-4 Canuck



Stearman 4EM Senior Speedmail

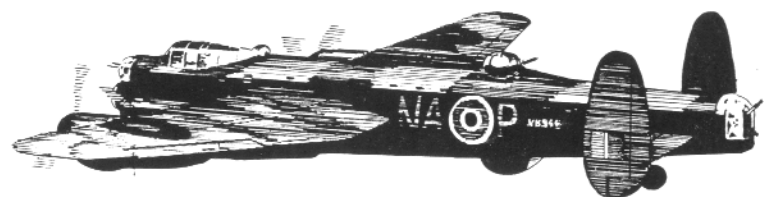

Avro Lancaster X