

GUIDELINES AND SPECIFICATIONS FOR GPS SURVEYS

RELEASE 2.1

December 1992

GEODETIC SURVEY DIVISION
CANADA CENTRE FOR SURVEYING
SURVEYS, MAPPING AND REMOTE SENSING SECTOR

Cette publication est disponible en français de la Division des levés géodésiques, Centre Canadien des levés, au numéro (613) 995-4421, sous le titre "Directives et spécifications pour les levés avec le système de positionnement global (GPS)"

TABLE OF CONTENTS

	Page
FOREWORD	iii
1. INTRODUCTION	1
2. GUIDELINES.....	3
2.1 Equipment Selection.....	3
2.1.1 Receiver and Antenna	3
2.1.2 Single Versus Dual Frequency Receivers	3
2.2 Reconnaissance.....	5
2.2.1 Site Selection	5
2.2.2 Station Marking.....	6
2.3 Survey Network Design.....	8
2.3.1 Control.....	8
2.3.2 Station Interconnection and Multiple Occupations	8
2.4 Field Observations	9
2.4.1 Antenna Setup	9
2.4.2 Length of Observation Session.....	10
2.4.3 Measurement Rate	11
2.4.4 Surface Meteorological Observations	11
2.4.5 Field Notes	12
2.5 Data Processing.....	12
2.5.1 Software and processing procedures	12
2.5.2 Ephemerides	13
2.5.3 Data Processing and Analysis.....	14
2.6 Report and Returns.....	15
3. GPS "SURVEY SYSTEM" VALIDATION SURVEY	16
3.1 Validation Network.....	16
3.2 Execution of the Validation Survey.....	17
3.3 Evaluation of Results.....	17
4. SPECIFICATIONS FOR THE CONDUCT OF GPS SURVEYS	19
4.1 Equipment Selection.....	19
4.2 Survey Network Design.....	19
4.3 Field Observations	20
4.4 Data Processing	21

TABLE OF CONTENTS

	Page
5. SPECIFICATIONS FOR GPS SURVEY REPORTING AND RETURNS	23
5.1 Project Description.....	23
5.2 Survey Procedures.....	23
5.3 Raw Data and Field Notes	24
5.4 Processing Procedures.....	24
5.5 Survey Results	25
 BIBLIOGRAPHY	 27
 APPENDIX A	GPS INFORMATION SOURCES
APPENDIX B	ACTIVE CONTROL SYSTEM
APPENDIX C	SURVEY MARKERS
APPENDIX D	SAMPLE GPS FIELD LOG FORMS

FOREWORD

Since 1983, Geodetic Survey Division has been involved with survey projects using the Global Positioning System (GPS). The information presented in this document is based largely on the experience gained during those projects but also on publications and specifications produced by other agencies. These publications are listed in the bibliography of the present guidelines.

We want to acknowledge in particular the work done by Geodetic Research Services Ltd. in developing specifications for urban GPS surveys under contract to the city of Edmonton. Their document was the first to promote the concept of pre-project validation surveys and this remains a key factor in Geodetic Survey's GPS contracts.

During the summer of 1992, EMR Canada participated in the three-month campaign to demonstrate the capabilities of an international GPS service (IGS) for geodynamics. Six stations of our prototype Active Control System (ACS) contributed continuous tracking data to the international computing centres during that period and several groups including EMR were able to compute precise GPS orbits daily at the sub-metre level using a global data set.

EMR and other federal departments are currently seeking private sector partner(s) to develop an operational differential GPS service, using our ACS data and modern computing and communications facilities, to serve a broad spectrum of applications.

It is expected that GPS will be declared fully operational by mid-1993 when the 21 satellite constellation is complete. The IGS is expected to become a permanent service in January 1994 and contribute to the maintenance of a global reference system.

Many individuals working in the Geodetic Survey Division have contributed to this document by their comments and suggestions. Their dedication to the goal of continuously improving our GPS capabilities and standards is gratefully acknowledged.

Again, as with previous releases of this document, we request that readers provide us with comments which could be incorporated in the future.

J. David Boal
Director & Dominion Geodesist
Geodetic Survey Division
Surveys, Mapping & Remote Sensing Sector
EMR Canada

1. INTRODUCTION

These guidelines and specifications are intended for surveys using the Global Positioning System (GPS) for the Geodetic Survey Division of the Department of Energy, Mines and Resources to ensure the efficient execution of survey operations within acceptable standards, both internally or under contract. Other organizations are welcome to use this document and to modify it according to their specific needs.

Because GPS equipment, observing techniques, applications and software are still evolving rapidly, and what is valid today may change tomorrow, it is almost impossible to establish rigid specifications for GPS surveys at this time without deterring the use of future developments. Current work on the so-called semi-kinematic, stop-and-go or rapid static applications, the completion of the full satellite constellation, the implementation of selective availability and anti-spoofing will affect the future capabilities of GPS.

In order to take advantage of the accumulated experience of GPS users and innovations in GPS positioning techniques, the concept of an acceptance test or **validation survey** is advocated to evaluate the mechanics (receiver type, observing procedures, processing techniques and software, etc.) proposed for a particular survey project, instead of a description of specific procedures to be followed. This acceptance test is carried out as a complete survey on a known network to confirm that the proposed procedures are capable of producing results at the accuracy level desired. Once the equipment, procedures and software are validated, they are adopted in their entirety for the conduct of the production survey for which they were proposed.

However, some aspects of a survey project, especially those judged necessary to ensure adequate redundancy and reliability, are specified in this document. The various aspects introduced fall into three categories of requirements. In this document the words "shall" or "must" indicates a mandatory requirement, "should" indicates a recommendation and "may" is a suggestion. Those aspects that are considered mandatory for the conduct of a GPS survey are summarized in Section 4 of the document. Specifications related to the reports and returns required for GPS survey projects are detailed in Section 5. Throughout this document, "project authority" refers to the Geodetic Survey Division for surveys carried out under contract and refers to the field surveys management group for projects carried out internally.

Because the application of GPS relative positioning techniques is relatively new and still evolving, these guidelines should not be construed as inflexible rules but as a framework which allow for innovation and change in the use of GPS technology as it evolves. It must be remembered that GPS is just another tool for establishing survey control, and as with other control survey methods, the principle of ensuring adequate redundancy and reliable positioning information are of the utmost importance regardless of the accuracy required.

This document is designed as an appendix to the upcoming revision of SPECIFICATIONS AND RECOMMENDATIONS FOR CONTROL SURVEYS currently in preparation at the Geodetic Survey Division. The latter should be referred to for accuracy standards and the classification of surveys.

2. GUIDELINES

2.1 EQUIPMENT SELECTION

2.1.1 Receiver and Antenna

Because the accuracy level required for geodetic work is only achievable from relative positioning, a minimum of two receivers must be used on any survey project. However, because of the advantages in using a larger number of receivers -- increased production rate, multiple connection to adjacent stations, repeated baselines and stronger geometric design -- use of at least four receivers is recommended for economy and efficiency.

Multi-channel code correlating receivers, tracking the phase of the carrier frequencies, are the most widespread surveying GPS receivers on the market at the present time. However, receivers using other observables, such as codeless squared beat carrier, code phase or other techniques that are in existence or may be developed, would also be acceptable if results obtained from a validation survey proved to be acceptable for the accuracy required.

Receivers of different models or manufacturers may be used on the same project. However, compatibility and observation synchronization must be verified during the validation survey.

Each antenna type has its own phase center definition which may vary with direction to the satellites. Ideally, an antenna type with the smallest sensitivity to multipath and the smallest phase center variation should be selected. Although the use of the same type of antenna for all receivers on the project is recommended to minimize phase centre biases, use of different antenna types is allowed but must be tested during the validation survey.

2.1.2 Single Versus Dual Frequency Receivers

For both dual and single frequency receivers, ionospheric disturbance can cause loss of lock and what appears to be noisy data (actually uncorrected ionospheric biases). The "noise" can be at the cycle level or greater, making it impossible to distinguish between ionospheric variations and cycle slips [H eroux, 1988]. With dual frequency receivers the major effect of the ionosphere can potentially be corrected for.

The behavior of the ionosphere is a function of many interrelated variables including the solar cycle, time of year, time of day, geographical location and geomagnetic activity.

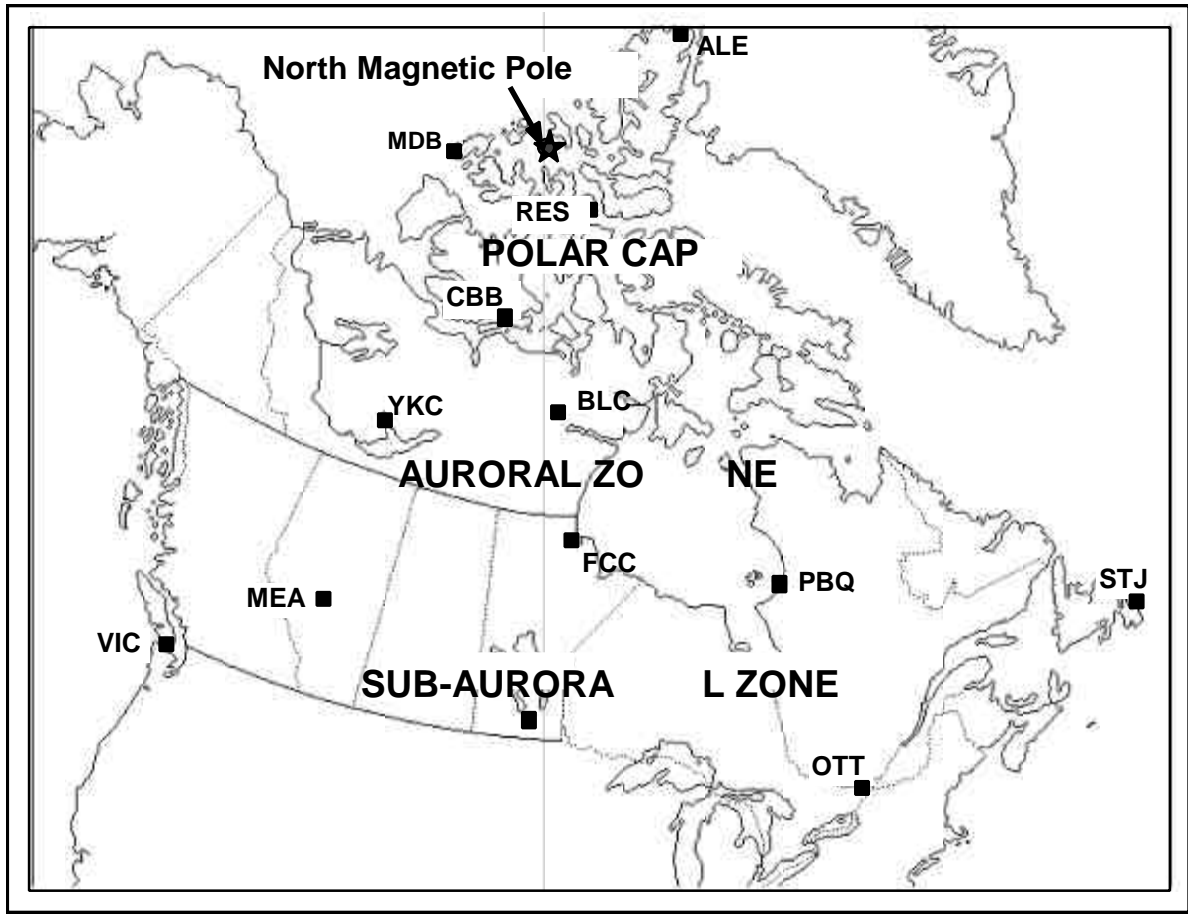

Canadian Magnetic Observatory Network		
Polar Cap	Auroral Zone	Sub-Auroral Zone
ALE Alert	CBB Cambridge Bay	MEA Meanook
RES Resolute Bay	BLC Baker Lake	GLN Glenlea
MDB Mould Bay	YKC Yellowknife	STJ St. John's
	FCC Fort Churchill	VIC Victoria
	PBQ Poste de la Baleine	OTT Ottawa

Figure 1. Geomagnetic Activity Zones in Canada

The Geophysics Division of the Geological Survey Sector at EMR monitors geomagnetic activities across the country and has determined three zones in Canada according to the average level of activity (see Figure 1). In the sub-auroral zone (Canadian southern latitudes), the magnetic flux is usually small and steady, leading to a generally homogeneous and predictable ionosphere. In the auroral and polar zones (latitudes of $\sim 55^\circ$ and higher), the magnetic flux is large and irregular leading to a generally disturbed ionosphere. The zone boundaries are not absolute and vary with seasons, solar cycles, sunspot activities, etc.. It should also be kept in mind that at all Canadian latitudes there

is potential for sudden disturbances in the earth's magnetic field (magnetic storms) causing large disturbances in the ionosphere.

In the auroral zone or higher latitudes, because of the unpredictability and irregularity of the ionosphere, dual frequency receivers are recommended for all surveys to ensure reliability of the data and are a mandatory requirement when second order accuracy (57 p.p.m., three-dimensional 95% confidence level) or better is sought.

In the sub-auroral zone (Canadian southern areas), where the ionosphere is more homogeneous, the ionospheric effect is distance dependent. Use of dual frequency receivers is also recommended for all surveys, but is mandatory when first order accuracy (23 p.p.m., three-dimensional 95% confidence level) or better is sought and baseline lengths consistently exceed 15 km.

When using single frequency receivers, additional precautions should be taken such as an increased number of repeated baselines, longer tracking sessions and additional connections between stations, to ensure that no systematic biases due to uncorrected ionospheric delay will affect the results at the accuracy level required for the project.

The Geophysics Division provides a forecast service to the public on the level of geomagnetic activity in the form of a long term forecast updated every three weeks, applicable for a 28 day period (one solar cycle) and short term predictions for a period of 72 hours updated daily. Actual geomagnetic observations at individual site of the monitoring network is also available. GPS users are encouraged to consult these forecasts and information before and during their campaigns.

2.2 RECONNAISSANCE

2.2.1 Site Selection

Once the general locations have been selected for the new stations and existing control stations have been identified (Section 2.3.1), field reconnaissance must be performed to select the specific sites, and to ensure that the stations, if already established, are suitable for GPS observations. Whenever possible, the use of existing markers instead of establishing new ones is highly recommended to avoid marker proliferation and to improve existing networks.

GPS observations require direct line of sight to the broadcasting satellites. Since the signal transmitted could be absorbed, reflected or refracted by objects near the antenna or between the antenna and the signal source, it is desirable that, at normal antenna height, the sky be unobstructed from 15° above the horizon. However, this is not a critical requirement in the northern directions (azimuths

between 315°- 45°) for Canadian mid-latitudes since the satellite sky distribution will always have a blank area in that direction where no satellite will ever be present. A polar plot (azimuth vs. zenith angle) of the satellite sky distribution for the latitude of the project is a very useful tool at the time of the reconnaissance to precisely identify this blank area where obstructions will not affect the satellite visibility.

Radar or microwave transmitting stations, radio repeaters and high voltage power lines may be sources of interference and their proximity should be avoided.

Multipath is the relative phase offset or time delay between directly and indirectly received radio signals. It is caused by reflections of the signal by nearby metallic objects or other reflective surfaces. In order to minimize this problem, the area within at least 50 metres of the marker should be free of artificial structures, particularly metal walls or fences, or natural reflective surfaces. An extended tracking period can sometimes reduce the effect of multipath through averaging and should be considered whenever the proximity of reflective surfaces cannot be avoided such as in urban area.

Station accessibility should also be considered when selecting a new site. Ideally the marker should be situated within 30 metres of the means of transportation (either by air or by road). For semi-kinematic or stop-and-go applications, the importance of this is obvious.

The terrain at the site selected should be such that stability and reasonable permanency for the marker is assured. The site should be on firm and stable ground, and not on soil susceptible to erosion, landslides or subsidence.

Where azimuth markers are required for follow-up surveys, GPS can be used for their positioning. For specific guidelines on the selection of these sites, the guidelines for selection of azimuth marker locations found in FIELD MANUAL FOR FIRST-ORDER HORIZONTAL CONTROL SURVEYS (1974) should be followed.

2.2.2 Station Marking

GPS provides a three-dimensional position. This characteristic should be reflected in the type of monument selected to mark the station. Because of the economics of establishing a new position by GPS versus the cost of constructing a sophisticated concrete structure to support the marker, standard concrete monuments (either cylindrical or pyramidal in shape) are no longer considered necessary except for specific projects. With this in mind, Table 1 indicates by order of preference the type of markers that should be used. A detailed

description of these markers is presented in appendix C. This list is not exhaustive and therefore, the project authority may authorize alternate markers.

MARKER TYPE	COMMENTS
1) tablet or bolt marker in bedrock, or large existing concrete structure	acceptable for any accuracy of survey
<p>2) NRC type deep bench mark consisting of a steel pipe driven to refusal and protected by an outer galvanized steel pipe. The datum point is attached at the top of the inner pipe and the annular space between the pipes is filled with heavy oil. A covered well filled with crushed stone provides additional horizontal stability and protection</p> <p>Note: Markers of this type, installed prior to 1988, require the addition of a horizontal stabilizer cap to prevent wobbling of the inner pipe.</p>	acceptable for any accuracy of survey
3) 3-D marker consisting of a datum point attached to steel rod sections (1.6 cm in diameter) driven to refusal. A covered well filled with tamped crushed stone provides additional horizontal stability and protection.	acceptable for any accuracy of survey
4) Helix pipe marker consisting of a brass cap attached to a 2.4 metre long section of square tubing with a steel helix spiral welded about 15 cm from the bottom end. A covered well filled with crushed stone provides additional horizontal stability and protection.	acceptable for any accuracy of survey
5) post marker consisting of a reinforcing steel rod with identification cap	Acceptable for surveys of accuracies of 57 ppm or better if used in permafrost or in weathered or soft rock (shale); and acceptable in any kind of soil for surveys of lower accuracies

Table 1
Recommended markers for GPS surveys.

2.3 SURVEY NETWORK DESIGN

2.3.1 Control

Control stations are used to ensure proper integration of the new survey within an existing framework. At least three control stations known three-dimensionally or an equivalent combination of horizontal and vertical control stations must be included in any GPS survey project.

For a local or regional network covering an area of up to 80 km x 80 km, the known control stations should be equilaterally distributed on the periphery of the network to be established.

If the survey covers a larger area, additional control stations are desirable and should be distributed regularly on the periphery and within the network. Ideally the total number of control stations and their distribution should be determined from a pre-analysis to ensure a reliable integration of the network within the national framework. However, wherever practical, existing framework stations within the project area should be included to improve their accuracy, to help resolve weakness and ensure homogeneity in the framework.

Permanent tracking sites, referred to as Active Control Points (ACPs) and maintained at a few locations across the country, can be used as control stations. Since ACP sites are very accurately positioned with respect to the existing NAD83 framework, by using only one GPS receiver in combination with ACS data, an immediate tie to NAD83 coordinates can be established. The accuracy, purpose and integration requirements of a given GPS survey project will still determine what additional vertical and horizontal ground control is required above the minimum indicated previously.

2.3.2 Station Interconnection and Multiple Occupations

A minimum number of direct connections (simultaneous observations) is necessary, to all stations to be positioned, in order to ensure sufficient redundancy and strength in the network adjustment. Ideally, each station will be directly connected to all adjacent stations. As a minimum, each station must be directly connected to at least two others in the network. This is essential for achieving reliable relative accuracies and proper integration of the GPS solution with the existing control.

Because it is generally easier to resolve the integer phase ambiguity over short baselines and because it provides a stronger network, simultaneous occupations of adjacent stations must be favored as opposed to observation of longer baselines.

Direct connections should also be made between control stations. This will provide an additional check on scale and orientation of the network and may also help resolve weakness in the existing control.

It is recognized that multiple occupations of a station (occupation for two or more independent sessions) provide the optimum reliability check on the position, permitting checks for blunders (e.g. centering error, incorrect antenna height, marker misidentification), as well as providing strength and redundancy for the network adjustment. However, for most projects, multiple occupations of all the sites may not be cost-effective and alternate procedures (see antenna setup section 2.4.1) must be in place to control the possibility of blunders. While multiple occupations are highly recommended for all surveys, it is a mandatory procedure when the three dimensional relative accuracy requirement is 5 ppm or better (95% confidence level).

The observation of common (repeated) baselines between adjacent sessions provides a better connectivity as well as ensuring a certain percentage of multiple occupations. It also allows for monitoring of variations in scale and orientation between observing sessions, due to changes in atmospheric conditions, orbital errors or other factors. Therefore, the observation scheme must be designed such that in the final network a common baseline exists from session to session. In other words, all sessions must be connected to the rest of the network such that a continuous link by means of common baselines is maintained throughout the whole survey. Lengths of these repeated baselines must be representative of the adjacent baseline lengths encountered in the project. If operating with only two receivers, every baseline needs to be repeated.

A detailed plan, at a suitable scale, showing existing control and new stations, which depicts for each session the proposed observation scheme (stations occupied simultaneously, repeated baselines, etc.) must be submitted for approval to the project authority before field observations begin.

2.4 FIELD OBSERVATIONS

2.4.1 Antenna Setup

Antenna setup (including marker identification, centering and measurement of antenna phase centre above the station mark) can be a major source of blunders in GPS field operations. Specific field procedures can minimize setup errors. This is particularly important since errors at this stage will easily go undetected unless comparison of vector components of repeated baselines can be performed.

A pictorial representation of the marker, such as a sketch with all inscriptions, a photograph or pencil rubbing, should be taken to confirm that the right marker has been occupied.

For all surveys, tribrachs allowing for leveling of the antenna together with an optical or mechanical device permitting accurate centering over the mark must be used. The centering device must be checked before and after the survey as well as every week for the duration of the survey .

For the highest accuracy surveys, such as geodynamic studies, a tribrach with a striding level and a rotating plummet assembly should be used. With this type of apparatus it can be determined immediately if the level needs adjustment or if the plummet has been knocked out of collimation.

The height of the antenna's phase centre above the station marker must be measured and recorded to the nearest millimetre before and after each observing session. Use of both metric and imperial systems is encouraged as a check. All measurements taken to derive the total height of the antenna phase centre above the marker must be recorded in the field log and the procedure should be described by a sketch in order to allow verification of the computation.

If the receiver is to remain at the same station for two or more observing sessions, the antenna must be re-positioned between each session, and the antenna height remeasured and recorded at the beginning and end of each session. This will ensure the independence of each observing session.

2.4.2 Length of Observation Session

The optimal length of the observation session (simultaneous data collection) is dependent upon several factors: the accuracy requirement, the satellite geometry, the ionospheric activity level, the type of receivers, the length of the baselines measured, the geographic location, the potential for multipath at the sites, the data reduction method and the software used. Experience combined with a pre-analysis of these factors for the area of the survey are probably the best way to determine the length of session required. The length of session selected must be proven adequate under the conditions expected for the production survey during the validation survey. The main criteria is to ensure that sufficient quality data are collected to adequately resolve carrier phase ambiguities.

It should be noted that the multipath effect is a function of the geometry of the satellite configuration observed. Since the geometry of the constellation is changing over time, a longer observation period will tend to average out somewhat the effect of multipath.

2.4.3 Measurement Rate

The choice of the measurement rate (data recording rate) is governed by the GPS technique used in the survey. The general rule is that the higher the measurement rate, the easier it is to detect and correct for cycle slips. On the other hand, a higher rate will generate cumbersome data files. In general, for static positioning, a recording rate of one observation every 15 seconds has been found adequate. For kinematic positioning a higher data rate may be required. For any technique, the recording rate must be proven adequate during the validation survey.

2.4.4 Surface Meteorological Observations

The requirement for surface meteorological observations is a function of the accuracy requirement, lengths of the baselines, height differences between stations, and purpose of the survey.

In general, for small and medium size networks (baseline lengths less than 100 km), meteorological observations are not required. For these cases, small errors in the meteorological observations, due to instrument calibrations, topography effects or local micro-climate effects can introduce larger biases in the tropospheric model than if a standard atmosphere (characterized by one set of surface meteorological data) is used with a model such as Saastamoinen or Hopfield [Beutler & al., 1988].

For surveys where accuracies in the order of 0.1 ppm or better are sought, or for large size networks where baseline lengths consistently exceed 100 km, or where there are large height differences between stations, surface meteorological observations may be required. For the latter case, where large height differences (e.g. several hundred metres) exist between stations, surface observations must be introduced in a model as explained in Beutler & al. [1989]. Meteorological observations are used to derive height dependent profile of the atmosphere in the layer between the lowest and highest stations surveyed. The final tropospheric delay is computed as the sum of delay below the highest station (based on the surface meteorological profile) and delay above the highest station using a standard atmosphere with models such as Saastamoinen or Hopfield.

When required, observations of meteorological conditions consisting of dry bulb temperature, wet bulb temperature or humidity, and atmospheric pressure should be recorded at the beginning and end of the observation session, whenever a sudden change in the conditions occurs, and at least every hour if the session lasts longer than one hour. Ideally the temperature and the humidity will be measured at a height of three metres or more above the ground level in order to avoid some of the surface heating effect. Temperatures should be recorded to the nearest 0.1 °C and humidity to the nearest 2%. The atmospheric

pressure should be measured at the height of the antenna and recorded to the nearest 0.3 millibar. The meteorological instruments must be compared against a standard prior to the survey project and brought together and compared at least once per week during the project. Corrective measures must be taken if differences are greater than the required precision.

A more sophisticated approach for modeling the tropospheric delay for precise or large networks is to model the delay at each station as a stochastic process, estimating values at each epoch, subject to a constraint on the permissible rate of change of the tropospheric conditions implied by the stochastic model. The stochastic estimation yields geodetic results which are comparable to those obtained by strategies using water vapor radiometers (WVR) [Tralli and Lichten, 1990].

2.4.5 Field Notes

A detailed field log , either digital or on paper must be maintained. Standard forms, similar to appendix D are adequate. The minimum information that must be included is:

- Date of observations (year, month, day and Julian day number)
- Session identification
- Station identification (name and number as provided by the project authority)
- Receiver model
- Serial numbers of receiver, antenna and data logger
- Height of antenna phase center above the marker (to 1 mm) and all measurements taken to derive that height (a sketch depicting the procedure is also recommended)
- Antenna offset from marker, if any (distance and azimuth)
- Starting and ending time (UTC) of observations
- General weather condition and changes, if any during the session
- Detailed meteorological observations, if required
- All problems or unusual behavior with equipment or satellite tracking.

An obstruction diagram, showing any obstructions at elevations greater than 15° as seen from the antenna location, may also be added to the field log.

2.5 DATA PROCESSING

2.5.1 Software and processing procedures

The software used for processing the data must produce relative positions or coordinate differences for stations observed simultaneously and associated rigorous variance-covariance statistics which can be used as input to a three-dimensional network adjustment program.

Ideally all mathematical and physical correlations among the GPS observations should be correctly accounted for in GPS processing. Although the correlations have less impact on the estimated coordinates, the associated accuracy estimates and statistics are greatly affected. This is especially important when integrating these results with larger networks.

Presently, software for modeling both physical and mathematical correlations are practically nonexistent. Until such software is readily available, only mathematical correlations can be routinely accounted for. The preferred approach is to directly model all the correlations using so-called session or multibaseline GPS processing software. At the present time, however, most commercial GPS software packages are only capable of separately processing individual baselines. Such baseline processing software does not account for the correlations between baselines. If baseline processing is used, then all baseline combinations (including those that are linear combinations of others) must be included in a network adjustment with each baseline covariance matrix scaled by $n/2$, where n is the number of stations observed simultaneously in the session. See Craymer and Beck [1992] for a more detailed comparison of session and baseline processing.

The software used for the adjustment must provide observation residuals (or the equivalent) which should be examined to ensure that no systematic effects remain. It must also be capable of producing the full formal covariance matrix of all the estimated coordinates.

Software and processing procedures must be successfully tested by processing data sets collected on the validation network before being adopted for a production survey.

2.5.2 Ephemerides

Satellite ephemerides used to compute satellite positions are either predicted and included in the broadcast GPS message, or are post-computed and available from various sources.

The broadcast ephemerides are predicted by the GPS Master Control Segment. These predictions are orbit extrapolations based on a reference orbit computed from five global monitoring sites.

The Naval Surface Warfare Center (NSWC) in cooperation with the U.S. Defense Mapping Agency (DMA) generates what is known as the "precise ephemerides". These post-computed ephemerides are based on data from ten global tracking sites. These orbits are also referred to as "fitted" orbits because they fit the entire data set and extrapolation is not required. These precise orbits however are presently unavailable to the public. The U.S. National Geodetic Survey (USNGS)

also generates post-computed ephemerides based on data collected at the CIGNET (Cooperative International GPS Network) tracking stations. These orbits are available to the public through the GPS Information Centre (GPSIC) bulletin board maintained by the U.S. Coast Guard (see appendix A). The Geodetic Survey Division of the Canada Centre for Surveying has started computing precise orbits from its Active Control System (ACS) network and additional tracking sites around the world and plans to establish an electronic distribution service to meet user needs.

Extrapolated (broadcast) ephemerides naturally have larger errors than precise ephemerides because they are subject to the effect of unmodelled perturbations. They are, however, adequate for most survey applications. Studies have shown that the broadcast ephemerides (not affected by Selective Availability) compare with NSWC/DMA precise ephemerides at the three to eight metre level depending on whether the satellites operate with Cesium or Rubidium clock [Remondi and Hofmann-Wellenhof, 1989]. This corresponds with an influence on relative positioning at the 0.2 to 0.5 parts per million range.

However, with the intentional degradation of the accuracy of broadcast ephemerides through Selective Availability, uncertainties in the orbital information of 100 metres or worse can be expected and precise or post-computed ephemerides may be required to achieve accuracies of a few parts per million. Time delays of a couple weeks to several months can be expected in attaining precise ephemerides from outside sources.

To obtain precise baselines at the 0.1 ppm accuracy level or better, the precise ephemerides may not be accurate enough. Another option is to use data collected at fiducial stations (continuous tracking stations peripheral to the project) and process them with the project's GPS observations. In this method, the fiducial stations are held fixed and the satellite orbital coordinates are adjusted while simultaneously solving for the station coordinate differences. With the introduction of selective availability and the possible intentional degradation of the orbital information, this might become a viable or even a preferred alternative to waiting for post-computed ephemerides.

2.5.3 Data Processing and Analysis

In order to quickly identify any problems with the data and to take the appropriate corrective action, the data should be processed as soon as possible after the observing session. All processing stages and unusual events, inconsistencies or errors must be logged. The following procedures provide information regarding the consistency and reliability of the data and should be carried out as frequently as possible (preferably daily).

The differences in repeated baseline measurements must be computed to check for blunders and to obtain initial estimates of the internal consistency of the GPS network. The differences should not exceed the accuracy requirement with respect to baseline length.

Wherever available, previously established baselines (between two control points for example) should be compared with the GPS network solution baseline. Discrepancies larger than those specified by the accuracy requirement for the survey should be investigated.

As the survey project progresses, new session solutions must be included in a minimally constrained adjustment (i.e. holding only one point fixed in all three coordinates) to monitor internal consistency of the network. Analysis of the normalized residuals (residuals multiplied by the square root of their weights) will help detect problem baselines and may indicate where some reobservations might be needed.

Upon completion of the project, a final network solution must be performed using the minimally constrained adjustment. NAD 83 coordinates or other known geocentric coordinates provided by the project authority must be used for the fixed station. The minimally constrained adjustment allows examination of the GPS results without the influence of the existing control.

If baseline processing is used, then all baseline combinations (including those that are linear combinations of others) must be included in a network adjustment with each baseline covariance matrix scaled by $n/2$, where n is the number of stations observed simultaneously in the session.

In addition, because existing GPS data processing software generally provides overly-optimistic covariance matrices, it is acceptable when justified to scale the formal covariance matrix provided by such software prior to the final adjustment. A scaling factor or algorithm may already be built into the GPS software package used. In any case, if the covariance matrix is scaled, the project authority must be informed of the scaling technique, the scaling must be applied to the entire covariance matrix so as not to affect the correlation, and the scaling technique must have been used for the validation survey.

2.6 REPORT AND RETURNS

The final report shall provide all the information necessary to evaluate the satisfactory completion of the project objectives. One of the intents is also to provide sufficient information in the returns to enable reprocessing of the raw data, if required. A summary of returns and report items are identified in Section 5.

3. GPS "SURVEY SYSTEM" VALIDATION SURVEY

The concept behind the validation survey is to evaluate the entire GPS "survey system" that is intended or proposed for use on a production survey, and to determine with confidence whether or not it produces reliable results that meet the accuracy requirement.

"Survey system" is defined here as the system used from the data collection stage to the final coordinates produced from a three-dimensional minimally constrained adjustment. This includes the equipment and all procedures used for data collection as well as equipment, software and procedures used for data processing and output of the final results.

The validation survey is carried out in a manner similar to a production survey. The main difference is that most stations have known coordinates which are used for evaluation of the test results by the project authority. The geometric design of the production network, and the logistics required to execute it are not verified during the validation survey but are addressed specifically in Section 4.

Once a GPS "survey system" has been successfully tested during a validation survey, it must be adopted in its entirety for the execution of the production survey for which it was proposed.

3.1 VALIDATION NETWORK

The validation network and specific stations to be positioned must be selected by the project authority. The validation network should have been established using methods which are expected to yield results superior to those expected for the production survey.

The network shall consist of a minimum of six stations that are as much as possible representative of the physical conditions expected on the production survey. This is particularly true for the geographical location (e.g. the latitude of the survey will determine to a great extent the degree of ionospheric activity) and for the interstation spacing and height differences.

Although not the only option, the GPS basenets currently being established across the country by the Geodetic Survey Division in collaboration with provincial survey agencies, meet all requirements necessary to carry out most validation surveys. Each basenet consist of six or more stations monumented by forced-centering pillars with interstation distances of approximately 2, 10, 40 and 50 kilometres at most locations and with additional distances of 100 and 150 kilometres at other strategic locations. As well, most basenets include an

Electronic Distance Measurement (EDM) calibration baseline which provides a selection of shorter lengths if required.

The requirement for such test networks throughout the country was identified in 1986. Early in 1987 Geodetic Survey published the PRELIMINARY RECOMMENDATIONS FOR ESTABLISHMENT OF GPS CALIBRATION BASENETS which have been followed for the design and implementation of the existing basenets.

3.2 EXECUTION OF THE VALIDATION SURVEY

For the validation survey, the guidelines provided throughout this document should be taken into consideration without limiting the use of innovative procedures. However, in order to satisfy the objectives of the validation survey, the observing scheme must accommodate some conditions (such as station multiple occupations, repeated baselines and sufficient redundancy) that will allow a thorough evaluation of the data.

In order to correlate as much as possible the results obtained from the validation survey with those expected from the production survey, the test should be carried out at approximately the same time of day (because of the high correlation with the ionospheric behavior) and with the same satellite configuration to what is planned for the production survey.

The results of the validation survey must be submitted according to the specifications described in Section 5. Sufficient information must be provided to permit the evaluation of both the internal and external accuracy of the results.

Since the statistical information provided by the GPS processing software is generally overly optimistic, it is acceptable, when justified, to scale the formal covariance matrices prior to the final adjustment. A scaling factor or algorithm may already be built into the GPS software package used. In any case, if the covariance matrix is scaled, the scaling technique must be applied to the entire covariance matrix and becomes part of the procedures being validated. Therefore, the same scaling technique must be used in the production survey.

3.3 EVALUATION OF RESULTS

A GPS "survey system" shall be considered acceptable for a particular production survey if the results from the validation survey meet the following conditions:

Internal accuracy:

The consistency checks described in Section 2.5.3 are completed with no unexplained discrepancies.

The three-dimensional 95% relative confidence regions of the final network solution determined from the network covariance matrix meet the accuracy requirement of the production survey.

External accuracy:

The final adjusted coordinates for any stations observed during the validation are statistically equivalent to the known values at the 95% confidence level.

A Helmert transformation of the final coordinates of the validation survey to the known coordinates, using up to seven parameters (three rotations, three translations and scale), may be performed to detect network wide systematic distortions caused by unmodelled biases in the GPS data. This analysis would help identify the problems, if results from the validation survey are not statistically equivalent to the known values.

Once a "survey system" has been validated, it must be adopted in its entirety for the execution of the production survey. If the equipment, procedures or software are modified in any way, the project authority must be informed, and if requested, the validation survey or portion of it repeated, depending on what has been modified. A change in the processing software only would not require the re-observation of the network although new computation and results analysis would be required.

4. SPECIFICATIONS FOR THE CONDUCT OF GPS SURVEYS

This section summarizes the mandatory requirements in the conduct of GPS surveys for the Geodetic Survey Division. Further information on recommended procedures is included in Section 2 of this document.

The entire GPS "survey system" that is intended or proposed for use on a production survey must be evaluated during a validation survey to determine with confidence whether or not it produces reliable results that meet the accuracy requirement. Once a "survey system" has been validated, it must be adopted in its entirety for the execution of the production survey. If the equipment, procedures or software are modified in any way, the project authority must be informed and if requested the validation survey or portion of it repeated depending on what has been modified.

4.1 EQUIPMENT SELECTION

Receivers of different models or manufacturers may be used on the same project. However, compatibility and observation simultaneity must be verified during the validation survey.

Although the use of the same type of antenna for all receivers on a project is recommended to minimize phase centre biases, use of different antenna types is allowed but must be tested during the validation survey.

In the auroral zone or higher latitudes, because of the unpredictability and irregularity of the ionosphere, dual frequency receivers are recommended for all surveys to ensure reliability of the data and are a mandatory requirement when second order accuracy (57 p.p.m., three-dimensional 95% confidence level) or better is sought.

In the sub-auroral zone (Canadian southern areas), since the ionosphere is more homogeneous, the effect of the ionosphere has a high correlation with station spacing. Use of dual frequency receivers is also recommended for all surveys, but is mandatory when first order accuracy (23 p.p.m., three-dimensional 95% confidence level) or better is sought and baseline lengths consistently exceed 15 km.

4.2 SURVEY NETWORK DESIGN

At least three control stations known three-dimensionally or an equivalent combination of horizontal and vertical control stations must be included in any GPS survey project.

Each station must be directly connected to at least two others in the network.

Because it is generally easier to resolve the integer phase ambiguity over shorter baselines and because it provides a stronger network, simultaneous occupations of adjacent stations must be favored as opposed to observation of longer baselines.

Multiple occupations (occupation for two or more independent sessions) are mandatory when the three-dimensional accuracy requirement is 5 ppm or better (95% confidence level).

The observation scheme must be designed such that in the final network a common (repeated) baseline exists from session to session. In other words, all sessions must be connected to the rest of the network such that a continuous link by means of common baselines is maintained throughout the whole survey. Lengths of these repeated baselines must be representative of the adjacent baseline lengths encountered in the project. If operating with only two receivers, every baseline needs to be repeated.

A detailed plan at a suitable scale showing existing control and new stations, which depicts for each session the proposed observation scheme (stations observed simultaneously, repeated baselines, etc.) must be submitted to the project authority before field observations begin.

A field reconnaissance must be performed to select the specific sites or to ensure that the stations, if already established, are suitable for GPS observations.

4.3 FIELD OBSERVATIONS

For all surveys, tribrachs allowing for leveling of the antenna together with an optical or mechanical device permitting accurate centering over the mark must be used. The centering device must be checked before and after the survey as well as every week for the duration of the survey .

The height of the antenna's phase centre above the station marker must be measured and recorded to the nearest millimetre before and after each observing session. All measurements taken to derive the total height of the antenna phase centre above the marker must be recorded in the field log.

If a receiver is to remain at the same station for two or more observing sessions, the antenna must be re-positioned between each session, and the antenna height remeasured and recorded at the beginning and end of each session.

The length of the observing session (simultaneous data collection) must be proven adequate under the conditions expected for the production survey during the validation survey.

The measurement rate (data recording rate) must be proven adequate during the validation survey.

A detailed field log, either digital or on paper must be maintained. The minimum information that must be included is:

- Date of observations (year, month, day and Julian day number)
- Session identification
- Station identification (name and number as provided by the project authority)
- Receiver model
- Serial numbers of receiver, antenna and data logger
- Height of antenna phase center above the marker (to 1 mm) and all measurements taken to derive that height (a sketch depicting the procedure is also recommended)
- Antenna offset from marker, if any (distance and azimuth)
- Starting and ending time (UTC) of observations
- General weather condition and changes, if any during the session
- Detailed meteorological observations, if required
- All problems or unusual behavior with equipment or satellite tracking.

4.4 DATA PROCESSING

The software used for processing the data must produce relative positions or coordinate differences for stations observed simultaneously and associated rigorous variance-covariance statistics which can be used as input to a three-dimensional network adjustment program.

The processing and network adjustment software should produce network (session) solutions that integrate all observations and stations and account for all the mathematical correlations. Preferably, session or multibaseline GPS processing should be used, where all mathematical correlations are directly modeled. If baseline software is used, all baseline combinations (including those that are linear combinations of others) must be included in the network adjustment with each baseline covariance matrix scaled by $n/2$, where n is the number of stations observed simultaneously in the session.

The software used for the network adjustment must provide observation residuals (or equivalent) which should be examined to ensure that no systematic effects remain. It must also produce the full formal covariance matrix of all the estimated coordinates.

Software and processing procedures must be successfully tested by processing data sets collected on the validation network before being adopted for a production survey.

All processing stages and unusual events, inconsistencies or errors encountered must be logged.

The differences in repeated baseline measurements must be computed to check for blunders and to obtain initial estimates of the internal consistency of the GPS network. The differences should not exceed the accuracy requirement with respect to length of the baseline.

As the survey project progresses, new session solutions must be included in a minimally constrained adjustment (i.e. holding only one point fixed in all three coordinates) to monitor internal consistency of the network. Analysis of the normalized residuals (residuals multiplied by the square root of their weights) will help detect problem baselines and may indicate where some reobservation might be needed.

Upon completion of the project, a final network solution must be performed using a minimally constrained adjustment. NAD83 coordinates or other known geocentric coordinates provided by the project authority must be used for the fixed station.

Because existing GPS data processing software generally provides overly-optimistic covariance matrices, it is acceptable when justified to scale the formal covariance matrix provided by such software prior to the final adjustment. A scaling factor or algorithm may already be built into the GPS software package used. In any case, if the covariance matrix is scaled, the project authority must be informed of the scaling technique, the scaling must be applied to the entire covariance matrix so as not to affect the correlation, and the scaling must have been used for the validation survey.

5. SPECIFICATIONS FOR GPS SURVEY REPORTING AND RETURNS

The final report of a GPS survey project shall provide all the information necessary to evaluate the satisfactory completion of the project objectives. Sufficient information must be provided in the report to enable reprocessing of the raw data, if required. The summary of report items identified below represents the minimum required for a project. Depending on the instrumentation or methodology used, additional information may be required.

5.1 PROJECT DESCRIPTION

A short description of the objectives of the project, location of the survey and number of stations positioned must be presented.

A map or map overlay showing all markers occupied must be submitted. The overlay shall be to scale and must show the baseline observations complete with the observation dates and times and must show common baselines between sessions.

5.2 SURVEY PROCEDURES

The returns submitted must be accompanied by a clear description of the survey procedures used in the field. The information provided should include but is not limited to the following:

- (i) A summary of the equipment used, including serial numbers, and a brief description of characteristics and principles of operation;
- (ii) Information related to specific procedures used in the field such as receiver oscillator warm up time period, time synchronization procedure (if applicable), antenna height determination procedure and data recording rate;
- (iii) A summary indicating for each session, the stations occupied, their respective start and end time of data collection and the satellites simultaneously observed;
- (iv) A description of procedures used for eccentric ties and an explanation of the need for an eccentric station if applicable;
- (v) Logistical information including: means of transportation, equipment deployment scheme, personnel involved and their duties, and difficulties encountered and how they were overcome.

5.3 RAW DATA AND FIELD NOTES

All original observational data collected in the field must be provided to the project authority. These include:

- (i) All measurement data (raw data) collected during the campaign on the original media, clearly labeled and described. If data are stored in internal memory, the first portable digital media to which they are transferred is considered "original" for the purpose of this requirement. Data should also be provided in RINEX (Receiver INdependent EXchange) format.
- (ii) The original field logs as described in section 4.3, in paper or digital form;
- (iii) Any conventional survey field notes from eccentric ties that were necessary for the completion of the project;
- (iv) Any updated station descriptions.

5.4 PROCESSING PROCEDURES

A detailed description of the procedures used for processing and verifying the data in the field or at the office must be presented. The information provided must include but is not limited to:

- (i) Computer and software (version number and date) used in the data processing and adjustment;
- (ii) A detailed description of how the following have been considered:
 - mathematical correlations between stations
 - scaling of the covariance matrix to account for the over estimation of the degrees of freedom if baseline processing software is used
 - scaling of the covariance matrix to account for overly optimistic error estimates
- (iii) Information and explanations about data editing performed including percentage of data rejected for each station and criteria for rejection;
- (iv) Description of the ionospheric and tropospheric models used;
- (v) A description of the cycle slip detection and rectification procedure;
- (vi) A summary of resolution strategies for carrier phase ambiguities and the results.

5.5 SURVEY RESULTS

The results must be presented in the format and on the media specified by the project authority and shall include:

- (i) The coordinate difference observations with associated covariance matrices for each individual session in the format specified by the project authority (GSD is currently requiring GHOST or GEOLAB format);
- (ii) The adjusted three-dimensional coordinates from the minimally constrained network adjustment along with the full, formal covariance matrices of the adjusted parameters (including nuisance parameters);
- (iii) The statistical testing of the results from the network adjustment including analysis of variance factors, semi-major axes of three-dimensional 95% relative confidence regions between all possible pairs of stations (which must respect the accuracy requirement of the project), residuals and residuals outliers;
- (iv) The results of any consistency check or data verifications such as agreement between repeated baselines, agreement with previously established baselines, comparison of baseline session solutions versus adjusted network solution.

BIBLIOGRAPHY

- Beck, N., R. Duval and P.T. Taylor (1989). "GPS Processing Methods: Comparison with Precise Trilateration: American Society of Civil Engineering, Journal of Surveying Engineering, Vol. 115, No. 4.
- Beutler, G. (1989). "Relative static positioning with the Global Positioning System: Basic considerations and recent results". Presented at Geodetic Survey Division, Ottawa, Ont., September.
- Beutler, G., I.Bauersima, W. Gurtner, M. Rothacher and T. Schildknecht (1988). "Atmospheric refraction and other important biases in GPS carrier phase observations". Monograph 12, School of Surveying, University of New South Wales, Australia.
- Beutler, G., W. Gurtner, M. Rothacher, T. Schildknecht and I.Bauersima (1986). "Using the Global Positioning System (GPS) for high precision geodetic surveys: highlights and problem areas". University of Bern, Astronomical Institute, Bern, Switzerland.
- Beutler, G., W. Gurtner, M. Rothacher, V. Wild. and E. Frei. (1989). "Relative Static Positioning with the Global Positioning System: Basic Technical Considerations." IAG/IUGG. 125th Anniversary General Meeting, Edinburgh, Scotland, August 3-12.
- Beutler, G., W. Gurtner, U. Hugentobler, M. Rothacher, T. Schildknecht and U. Wild (1988). "Ionosphere and GPS processing techniques". Presented at the Chapman Conference on the Use of GPS for Geodynamics, Fort Lauderdale, Florida, September 19 - 22.
- Clynch, J.R. and D.S. Coco (1986). "Error characteristics of high quality geodetic GPS measurements: clocks, orbits, and propagation effects". Presented at the Fourth Int. Symposium on Satellite Positioning, Austin, Texas, April 28 - May 2.
- Cover, C. (1988). "The impact of ionospheric disturbances on GPS data". Proceedings, 1988 In-House R & D Symposium, Geodetic Survey of Canada, Ottawa, Ont., March.
- Craymer, M.R. and N. Beck (1992). "Session versus baseline GPS processing." Proceedings of the 5th International Technical Meeting of the Institute of Navigation, ION GPS-92, Albuquerque, NM, September 16-18.

- Craymer, M.R., D.E. Wells and P. Vanícek (1989). Report on urban GPS research project phase III – Evaluation, Volume 3: Specifications and guidelines. Contract report for the City of Edmonton, Transportation Dept., Engineering Division, Edmonton, Alberta. Geodetic Research Services Limited, Fredericton, N.B.
- Craymer, M.R., D.E. Wells, P. Vanicek and R. Devlin (1990). "Specifications for Urban GPS Surveys." *Surveying and Land Information Systems*, Vol. 50, No. 4, pp. 251-259.
- Delikaraoglou, D. and F. Lahaye (1989). "Optimization of GPS theory, techniques and operational systems: progress and prospects". IAG/IUGG 125th Anniversary General Meeting, Edinburgh, Scotland, August 3-12.
- Geiger, A. (1988). "Simulation of disturbing effects in GPS measurements by continuous satellite distribution". Presented at GPS'88 - Engineering applications of GPS satellite surveying technology, American Society of Civil Engineers annual meeting, Nashville, TN, May 11-14.
- Geodetic Survey of Canada (1987). "Preliminary recommendations for establishment of GPS calibration basenets". Geodetic Survey Division, Surveys, Mapping and Remote Sensing Sector, Energy, Mines and Resources Canada, Ottawa, Ont., February.
- Georgiadou, Y. and A. Kleusberg (1988). "On the effect of ionospheric delay on geodetic relative GPS positioning". *Manuscripta geodaetica* 13, 1-8.
- Gurtner, W. and G. Mader, (1989). "Receiver Independent Exchange Format Version 2". GPS bulletin vol.3, no.3 . CSTG GPS subcommission, Rockville, MD.
- Héroux, P. (1988). "Experiences processing GPS data from Canadian auroral zone with DIPOP 2.0". Department of Surveying Engineering, University of New Brunswick, Fredericton, N.B.
- Héroux, P. (1988). "GPS and the ionosphere in auroral regions". Department of Surveying Engineering, University of New Brunswick, Fredericton, N.B.
- Hothem, L.D. (1988). "GPS surveying standards and specifications". Presented at GPS'88 - Engineering applications of GPS satellite surveying technology, American Society of Civil Engineers annual meeting, Nashville, TN, May 11-14.
- King, R.W. and G. Blewitt (1989). "Present capabilities of GPS for high precision regional surveys". IAG/IUGG 125th Anniversary General Meeting, Edinburgh, Scotland, August 3-12.

- Kouba, J. (1986). "GPS Capabilities and Limitations for Geodynamics". Internal report, Geophysics Division, GSC, EMR. Dec.
- Lichten, S.M. and S. Kornreich Wolf (1989). "Stochastic GPS estimation of tropospheric path delays". Presented at AGU Fall Meeting, San Francisco, California, December 4-8.
- Ministère de l'Énergie et des Ressources du Québec, (1989). Instructions pour les levés géodésiques par la méthode GPS. Service de la géodésie, publication no PT8903D10, Sainte-Foy, Qué.
- Minkel, D.H. (1988). "GPS antenna - Field operation aspects: equipment, set-up procedures, and error sources". Presented at GPS'88 - Engineering applications of GPS satellite surveying technology, American Society of Civil Engineers annual meeting, Nashville, TN, May 11-14.
- Mrstik, P. (1990). Private communication about data processing and verification in the field, Geosurv Inc., Ottawa, Ontario.
- National Mapping Council of Australia, (1989). "Standards and specifications for control surveys", draft no.7.
- Neilan, R.E. (1987). "JPL standards for GPS site selection, monumentation, and referencing". Document 335.4-87-70, Jet Propulsion Laboratory, Pasadena, CA.
- Rapatz, P.J.V., M.Craymer, A. Kleusberg, R.B. Langley, S.H. Quek, J. Tranquilla and D.E. Wells (1987). Specifications and procedures for urban GPS surveys. Department of Surveying Engineering, University of New Brunswick, Fredericton, N.B.
- Rapatz, P.J.V., R. Devlin, C. Barnes and D.E. Wells (1988). "GPS specifications for urban surveys". Presented at GPS'88 - Engineering applications of GPS satellite surveying technology, American Society of Civil Engineers annual meeting, Nashville, TN, May 11-14.
- Remondi, B.W. and B. Hofmann-Wellenhof (1989). "GPS Broadcast Orbits versus Precise Orbits: A Comparison Study". Presented at IAG/IUGG 125th Anniversary General Meeting, Edinburgh, Scotland, August 3-12.
- Santerre, R. (1989) "GPS satellite sky distribution: Impact on the propagation of some important errors in precise relative positioning". Ph. D. dissertation, Department of Surveying Engineering Technical Report No. 145, University of New Brunswick, Fredericton, New Brunswick.

- Steeves, R.R., P. Héroux, D.J. McArthur and K. Lochhead (1987). "Development of GPS data processing software at the Canadian Geodetic Survey". Presented at the 80th annual general meeting of the Canadian Institute of Surveying and Mapping, Charlottetown, P.E.I., June 22-26.
- Surveys and Mapping Branch, (1974). "Field manual for first-order horizontal control surveys". Department of Energy, Mines and Resources Canada, Ottawa, Ont.
- Surveys and Mapping Branch, (1978). "Specifications and recommendations for control surveys and survey markers". Department of Energy, Mines and Resources Canada, Ottawa, Ont.
- Tralli, D.M. and S.M. Lichten (1990). "Stochastic estimation of tropospheric path delays in Global Positioning System geodetic measurements". Bulletin Géodésique, 64, 127-159.
- Tranquilla, J.M. (1986). "Multipath and imaging problems in GPS receiver antennas". Presented at the Fourth Int. Symposium on Satellite Positioning, Austin, Texas, April 28 - May 2.
- Wells, D.E., N. Beck, D. Delikaraoglou, A. Kleusberg., E.J. Krakiwsky, G. Lachapelle., R. Langley, M. Nakiboglu., K.P. Schwarz, J. Tranquilla, P. Vanicek. (1986). Guide to GPS Positioning. Canadian GPS Associates, Fredericton, New Brunswick.

GPS INFORMATION SOURCES

GPS INFORMATION SOURCES

GEOMAGNETIC ACTIVITY PREDICTION

The Geophysics Division of the Department of Energy, Mines and Resources provides a forecast service to the public on the level of geomagnetic activity. A long term forecast updated every three weeks, applicable to a 28 day period (one solar cycle) is mailed on a regular basis to those requesting it and short term predictions for a period of 72 hours updated daily is available in a detailed form via computer link or summarized on a voice recorded message. GPS users are encouraged to consult these forecasts before and during their campaigns.

The voice recorded forecast (72 hours) is available at (613) 992-1299.

To be included in the mailing of the long term forecast or to access the detailed short term forecast contact the Chief Geomagnetic Forecaster at (613) 837-3527 or in writing:

Geomagnetic Forecasting Service
Geophysics Division
1 Observatory Crescent
Ottawa, Ontario
K1A 0Y9

It is also possible to receive actual geomagnetic data collected at individual monitoring sites. This information is sometimes useful to corroborate that problem data are caused by high ionospheric activity. Instructions on how to access this information can be obtained at the address above.

SATELLITE STATUS

(i) GPS Information Centre

The Global Positioning System Information Centre (GPSIC) provides civilian users of the NAVSTAR GPS with system status and other information. The GPSIC is operated by the U.S. Coast Guard. It receives GPS status messages from the U.S. Air Force, which has operational control of the system, and gives the information wide

dissemination. Although the information is only updated during the GPSIC's working hours, advisory services are accessible 24 hours a day, seven days a week.

The information available consists of current constellation status (satellites healthy/unhealthy), recent outages, future scheduled outages, current orbital descriptions (almanac data) suitable for making GPS coverage and satellite visibility predictions, and precise orbital ephemerides computed by the U.S. National Geodetic Survey (NGS).

A brief summary of the constellation status is available on voice recording at (703) 313-5907. More detailed information is available through a computer bulletin board. Anyone can use this bulletin board at no charge. Registration is done on-line on the first session. The bulletin board may be accessed at (703) 313-5910 for modem connections at 300 to 14400 bps. Comms parameters are: 8 data bits, 1 stop bit, no parity.

For additional information on the Centre or the bulletin board write to the Commanding Officer, U.S. Coast Guard, Omega Navigation System Center, 7323 Telegraph Road, Alexandria, VA 22310-3998, U.S.A. or call (703) 313-5900

(ii) Naval Observatory GPS Bulletin Board

Operated by the U.S. Air Force Naval Observatory in Washington, D.C., this bulletin board offers clock data and general GPS information, including constellation status, electronic mail, downloadable files and user advisories.

The bulletin board can be accessed at either (202) 653-0155 or (202) 653-0068. The comms parameters are: no parity, 8 data bits and 1 stop bit. The password "CESIUM133" must be used to access the system and continue with on-line registration.

Further information or assistance is available at (202) 653-1525 or at (202) 653-1034.

(iii) Holloman GPS Bulletin Board Service

Operated by the U.S. Air Force at Holloman Air Force Base, New Mexico, this bulletin board offers GPS information including constellation status, almanac data, electronic mail, downloadable files, and user advisories.

The bulletin board can be accessed at (505) 679-1525. The system uses a "smart" modem and will automatically adjust for protocols. For further information or assistance contact (505) 679-1657 or (505) 679-1787.

POST COMPUTED EPHEMERIDES

Precise orbital ephemerides based on computations of tracking data collected from stations of the Cooperative International GPS Tracking Network (CIGNET) are computed by the U.S. National Geodetic Survey. Satellite orbital data are available two weeks after the tracking data are collected on the GPS Information Center's bulletin board (access procedures provided earlier in this appendix).

If the user requires orbits for weeks no longer posted on the GPSIC bulletin board, the orbits may be obtained on high density floppy disks for a fee, by contacting the NGS Information Center at:

National Geodetic Information Center
N/CG174, Rockwall Building, Room 24
National Geodetic Survey, NOAA
Rockville, MD 20852 USA
Phone: (301) 443-8631

The Geodetic Survey Division of the Canada Centre for Surveying does not provide a post computed ephemerides service at the present time but plans to provide this service in the future and to establish an electronic distribution service to meet user needs. For further information contact :

Canada Centre for Surveying
Geodetic Survey Division
Information Services
615 Booth Street
Ottawa, Ontario K1A 0E9
Phone: (613) 995-4421

ACTIVE CONTROL SYSTEM

THE ACTIVE CONTROL SYSTEM

The Geodetic Survey Division of the Survey, Mapping and Remote Sensing Sector, in partnership with Geological Survey of Canada, is presently testing a prototype Active Control System (ACS) to support the rapidly growing Canadian GPS user community. The system consists of a number of automated GPS tracking stations, referred to as ACPs (Active Control Points), which continuously record carrier phase and pseudorange measurements for all GPS satellites in view. The data collected at each ACP is transmitted on a daily basis to a central processing facility in Ottawa. The ACS is expected to substantially improve the effectiveness of GPS applications. It has four main objectives: (1) to monitor and verify GPS integrity and performance by analyzing data acquired through continuous tracking; (2) to compute precise orbital ephemerides for geodetic positioning using data from the Canadian ACPs and a few international tracking stations; (3) to serve as control and calibration sites for GPS users; (4) to evaluate and distribute differential GPS corrections.

Presently, prototype ACPs are located in Yellowknife N.W.T., Penticton B.C., Algonquin Park Ont., St. John's Nfld. and Victoria B.C.. Each ACP is equipped with a high precision dual frequency GPS receiver and an atomic frequency standard. Temperature, pressure and humidity data are also collected at selected ACP sites. Data validation and single point positioning, performed for each individual ACP, provide measures of GPS system performance and the status of selective availability (Héroux and Caissy, 1992).

The availability of precise orbits based on GPS tracking data is expected to offer significant benefits for Canadian users carrying out geodetic surveys. By using ACS precise orbits, all orbit related errors in GPS baseline determinations will be reduced to about 0.1 ppm whereas errors due to broadcast orbits subjected to selective availability can be as high as 5 ppm. The use of ACS precise orbits will result in more efficient GPS data processing, improving cycle slip detection and correction, and resolution of carrier phase ambiguities. Because precise orbits reduce systematic scale and orientation errors, the number of control points required for integration with NAD83 may be reduced, increasing the efficiency of field operations and data processing. Since ACP sites are very accurately positioned with respect to the existing NAD83 framework, by using only one GPS receiver in combination with ACS data an immediate tie to NAD83 coordinates can be established. The accuracy, purpose and local NAD83 integration requirements of a given GPS survey project will determine what additional vertical and horizontal ground control is required, as discussed in the Guidelines and Specifications for GPS Surveys.

The ACS currently serves Canadian GPS users by providing integrity information and making available data collected at continuously tracking ACPs. Precise orbits will enhance achievable accuracies for surveyors as well as the productivity and efficiency of survey operations. As the full GPS constellation becomes available in 1993, the impact of the ACS approach for a wide range of applications will be clearly demonstrated.

Reference

Héroux, P. and M. Caissy (1992). "Canada's Active Control System Data Acquisition and Validation." Presented at The 85th Annual Meeting of the Canadian Institute of Surveying and Mapping, Whitehorse, Yukon, June 23-26.

SURVEY MARKERS

- C.1 Tablet and bolt marker
- C.2 NRC type deep bench mark
- C.3 3-D marker
- C.4 Helix pipe marker
- C.5 Post marker

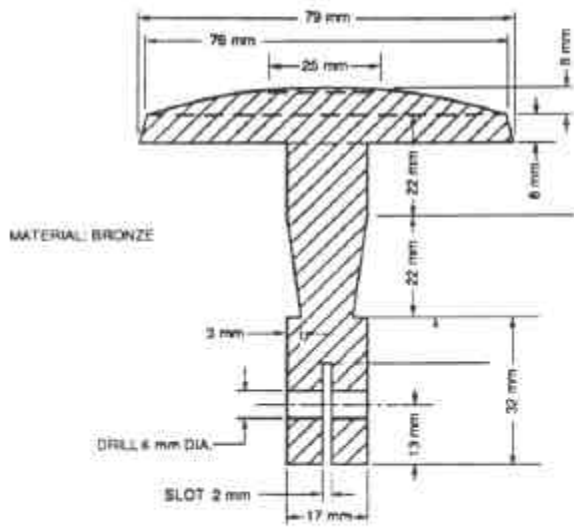

Tablet Marker

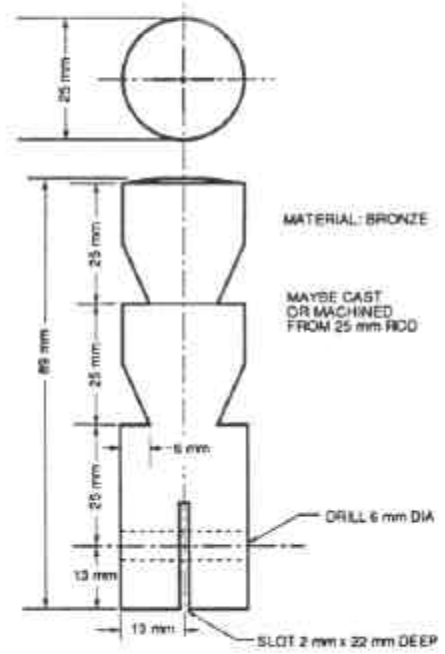

Bolt Marker

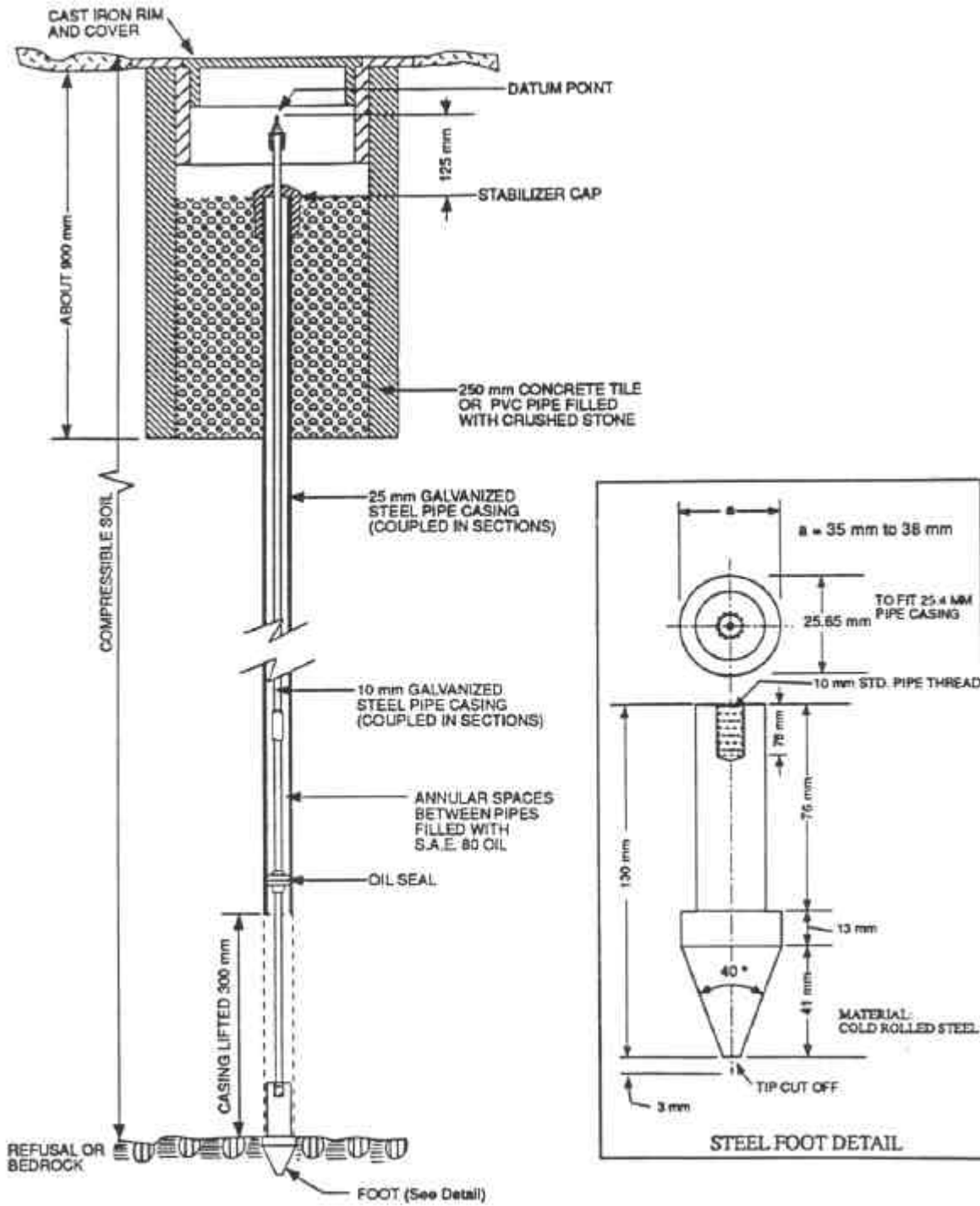

NRC Type Deep Bench Mark

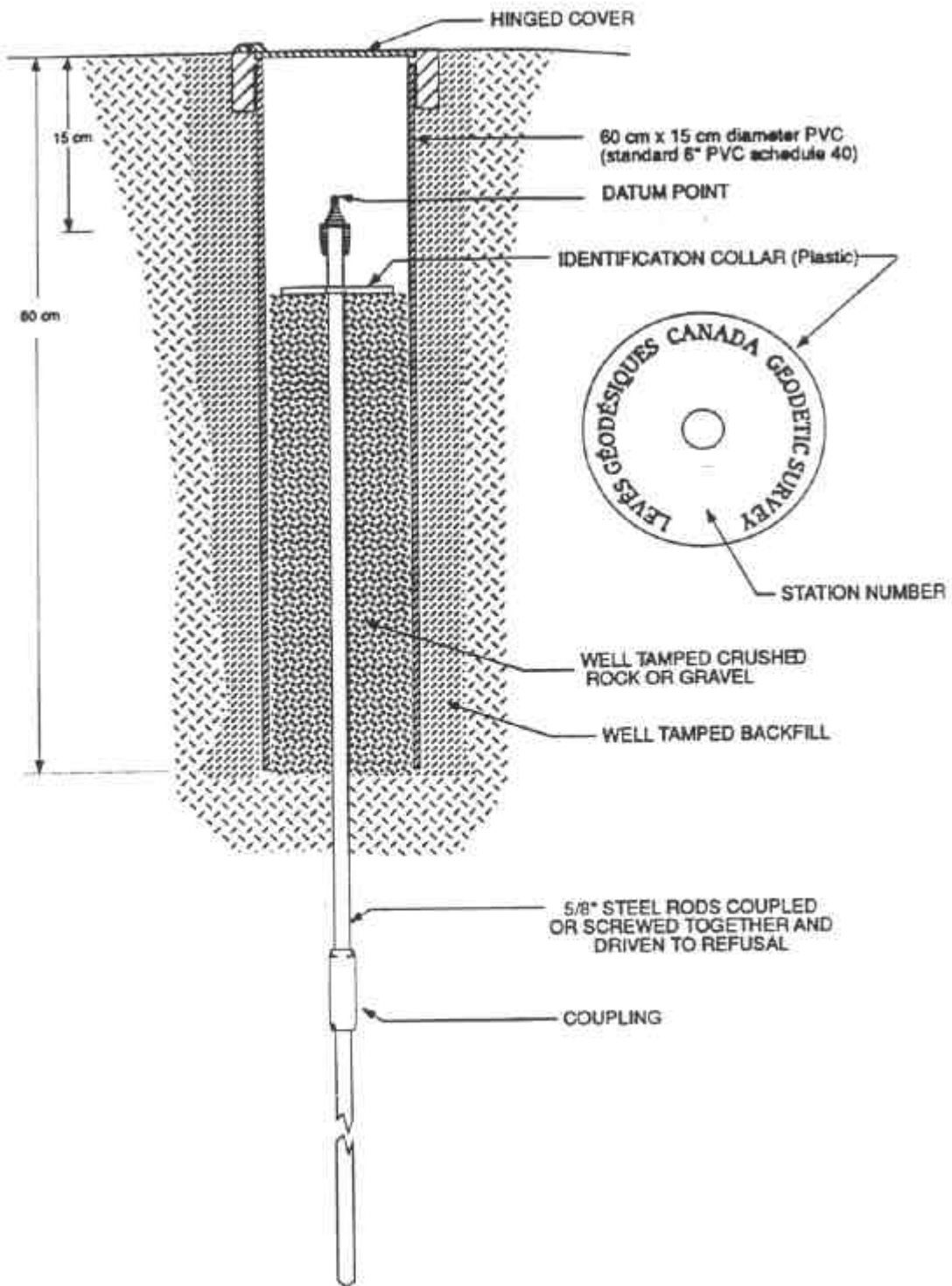

3-D Marker 1990

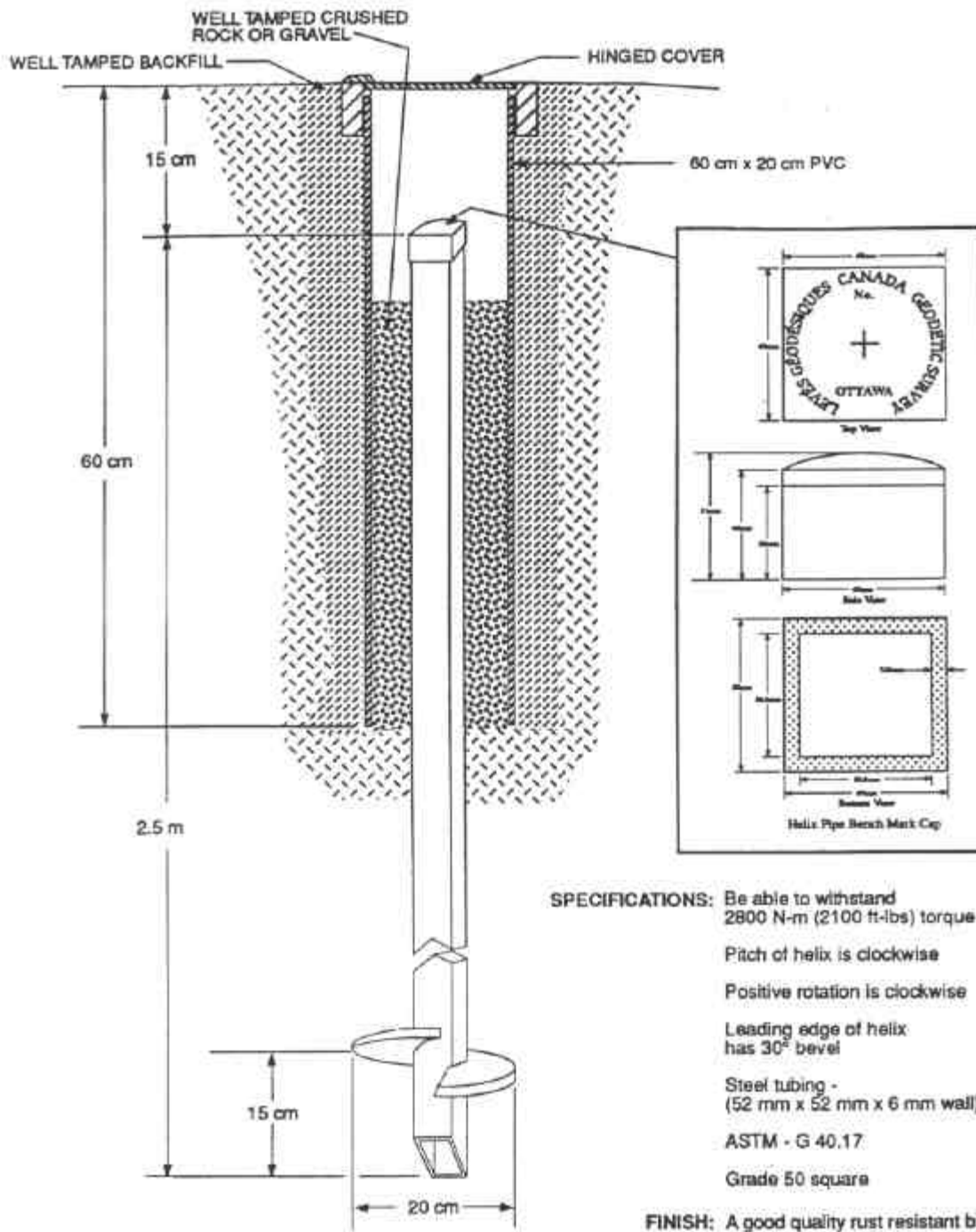

Helix Pipe Marker

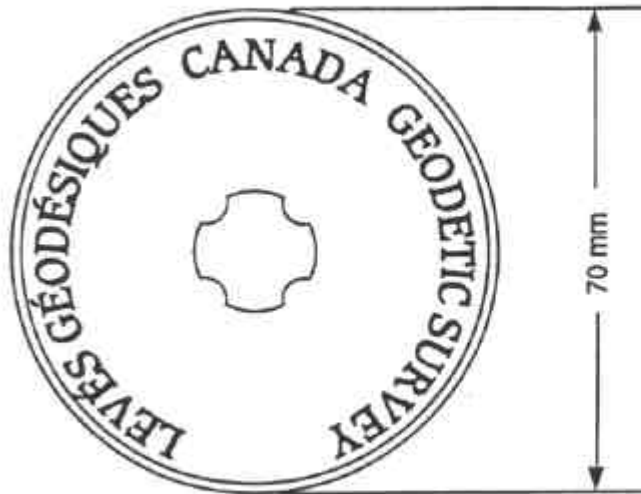

TOP VIEW

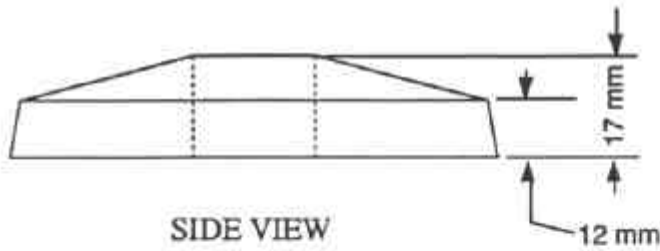

SIDE VIEW

Cast Aluminum Cap.

Use with unthreaded No. 6 reinforcing steel bar.
Peen top of bar to retain cap.

Top of bar must be centre punched after installation.

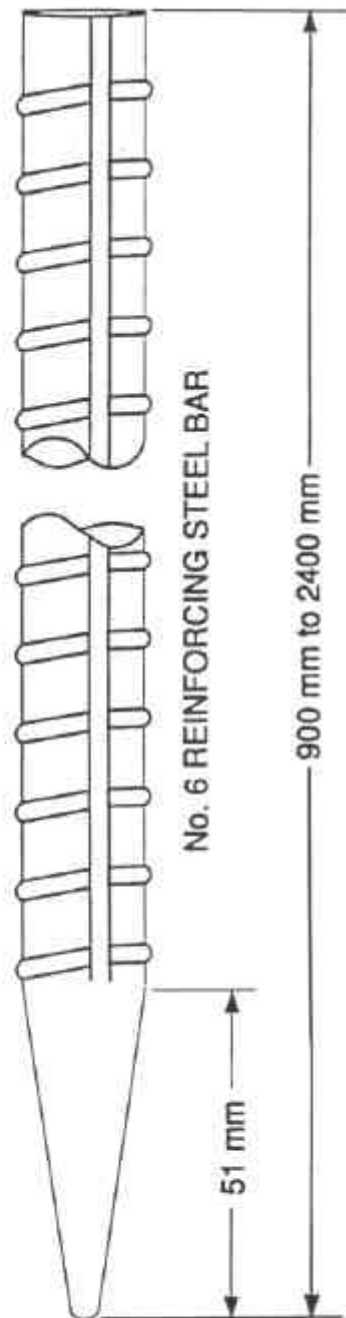

Post Marker

SAMPLE GPS FIELD LOG FORMS

GPS FIELD LOG

Page 1 of _

Project Name _____ **Project Number** _____

Receiver Model/No _____	Station Name _____
Receiver Software Version _____	Station Number _____
Data Logger Type/No _____	4-Char ID _____
Antenna Model/No _____	Date _____
Cable Length _____	Obs. Session _____
Ground Plane Extensions Yes () No ()	Operator _____

Data Collection	Receiver Position
Collection Rate _____	Latitude _____
Start Day/Time _____	Longitude _____
End Day/Time _____	Height _____

Obstruction or possible interference sources _____

General weather conditions _____

Detailed meteorological observations recorded : Yes () No ()

Antenna Height Measurement

Show on sketch measurements taken to derive the antenna height. If slant measurements are taken, make measurement on two opposite sides of the antenna. Make measurements before and after observing session.

Vertical measurements ()	
Slant measurements (): radius _____ m	
BEFORE	AFTER
_____ m _____ in	_____ m _____ in
_____ m _____ in	_____ m _____ in
Mean _____ m	
Corrected to vertical if slant measurement _____ m	
Vertical offset to phase centre _____ m	
Other offset (indicate on sketch) _____ m	
TOTAL HEIGHT _____ m	

Verified by: _____

GPS STATION OBSTRUCTION DIAGRAM

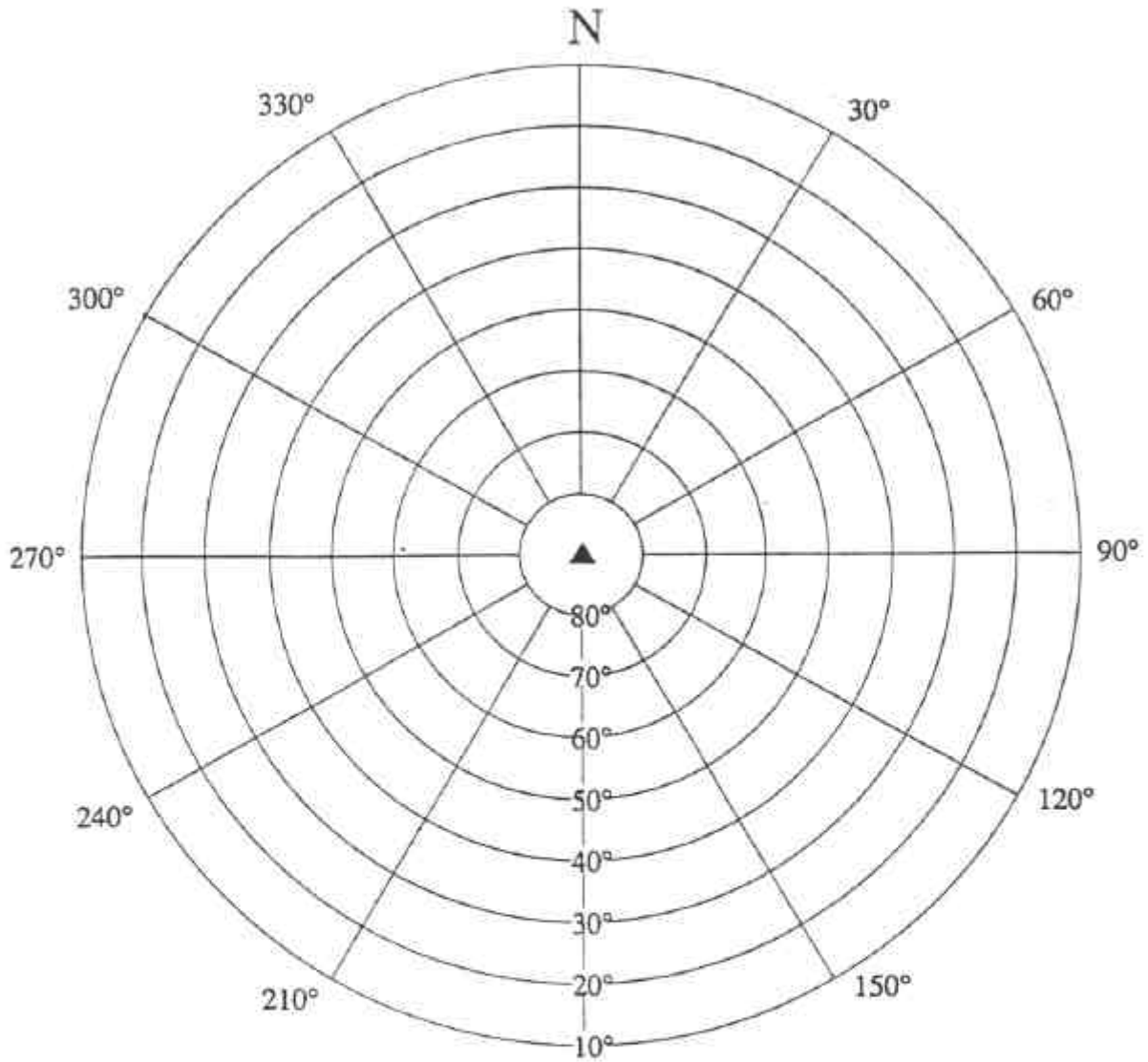

Identify obstructions and their elevation angle as seen from the station mark.

Indicate the distance to any metallic structure or reflective surface.

Magnetic Declination _____

Declination applied to this figure? Yes { }
No { }

Height above marker that horizon was mapped from: _____

Station Name _____	Date _____
Station Number _____	Operator _____

