

**ADDITION OF OFF BOARD GENERATION  
OF HYDROGEN FUEL  
FOR FUEL CELL VEHICLES TO GHGENIUS**

Prepared for:

Natural Resources Canada  
12<sup>th</sup> Floor  
580 Booth Street  
Ottawa, Ontario  
K1A 0E4

Attention: Ruth Talbot

Prepared by:

Levelton Engineering Ltd.  
# 150 - 12791 Clarke Place  
Richmond, British Columbia  
V6V 2H9

in association with:

(S&T)<sup>2</sup> Consultants Inc.  
11657 Summit Crescent  
Delta, British Columbia  
V4E 2Z2

August 15, 2002



## EXECUTIVE SUMMARY

The Canadian Transportation Fuel Cell Alliance (CTFCA) is a \$23 million federal government initiative that will demonstrate and evaluate fuelling options for fuel cell vehicles in Canada. Different combinations of fuels and fuelling systems will be demonstrated by 2005 - for light, medium and heavy-duty vehicles. The initiative will also develop standards, training, and testing procedures as related to fuel cell and hydrogen technologies.

The Program focuses its efforts on showcasing refueling demonstration projects, evaluating different fuelling routes for light-, medium- and heavy-duty fuel-cell vehicles, monitoring the resulting greenhouse gas emission reductions, and developing the necessary supporting framework for the fuelling infrastructure, including technical codes and standards, training, certification and safety.

The Studies and Assessments Working Group is the research arm of the CTFCA Program. It assists the other working groups by developing a grid to steer their work and produces a compendium of existing technological, socio-economic and environmental studies in the area of fuelling pathways. The Working Group has access to NRCan's in-house model (GHGenius) to run data generated by the demonstration projects. Information from this model is needed to assess emissions performance and costing evaluations of fuelling pathways.

The purpose of this work is to add fuel cycles to the model that may be demonstrated in the CTFCA demonstrations and allow an assessment of the projected greenhouse gas benefits before the projects are funded by the CTFCA.

The GHGenius model has been successfully updated with additional hydrogen production and hydrogen utilization pathways. The following hydrogen production pathways have been added:

- Off board reforming of methanol
- Off board reforming of ethanol
- Off board reforming of gasoline
- Off board reforming of FT Distillate
- Off board reforming of LPG
- The use of nuclear energy to produce hydrogen through thermal cracking

In addition, the use of mixtures of natural gas and hydrogen (Hythane®) in both light duty spark ignited engines and in heavy-duty natural gas engines have been added to the model. The hydrogen for these mixtures can be produced either from SMR or from electrolysis.

The default values that have been programmed into the model have been based on commercial data wherever possible. With these values the only hydrogen production pathways that would appear to have potential from a GHG perspective are the off board methanol to hydrogen cycle and the nuclear route. The nuclear pathways are estimated by their developers to be 30 years from commercialization. There is considerable effort being undertaken developing improved technologies, such as autothermal reforming, for producing hydrogen using the feedstocks that have been added to the model. The model will accurately predict the emissions from these new technologies once the operating parameters are known. This will allow the CTFCA to analyze the greenhouse gas benefits of demonstration projects before the projects are funded by the CTFCA.

There is full functionality in the model for the additional hydrogen pathways. All of the results such as the energy balances of the pathways, the energy efficiency on a per mile driven basis,

the cost effectiveness of the GHG emission reductions and the summary of the all emissions by stage of production are available in the model.

The following table summarizes the GHG emissions for the new hydrogen production cycles on a well to tank basis. The results are compared to the steam reforming of natural gas.

**Table ES-1 GHG Emissions Summary**

	Hydrogen from SMR	Methanol to Hydrogen	Gasoline to Hydrogen	FT Distillate to Hydrogen	Corn Ethanol to Hydrogen	Cellulose Ethanol to Hydrogen	LPG to Hydrogen
	Gm/million BTU	Gm/million BTU	Gm/million BTU	Gm/million BTU	Gm/million BTU	Gm/million BTU	Gm/million BTU
Fuel Dispensing	3,650	3,650	3,650	3,650	3,650	3,650	3,650
Fuel Distribution	0	0	0	0	0	0	0
Fuel Production	76,160	77,671	137,310	130,926	5,077	5,077	122,351
Feedstock Transmission	3,289	7,078	2,383	5,028	2,691	2,691	2,474
Feedstock Recovery	5,621	17,646	42,459	56,379	82,341	16,541	8,425
Land use change	0	0	0	0	18,036	1,679	0
Fertilizer manufacture	0	0	0	0	11,266	1,320	0
Gas Leaks and Flares	5,280	3,783	5,043	7,221	0	0	4,085
CO <sub>2</sub> removed from NG	963	1,129	0	2,155	0	0	1,265
Co-products	0	0	0	0	-44,836	-7,078	0
<b>Total</b>	<b>94,954</b>	<b>110,957</b>	<b>190,846</b>	<b>205,359</b>	<b>78,226</b>	<b>23,880</b>	<b>142,249</b>

# TABLE OF CONTENTS

1. INTRODUCTION .....	1
1.1 BACKGROUND.....	1
1.2 STUDY OBJECTIVES.....	2
2. HYDROGEN PRODUCTION CYCLES .....	4
2.1 METHANOL TO HYDROGEN.....	4
2.1.1 System Requirements .....	5
2.2 LPG REFORMING .....	6
2.2.1 System Requirements .....	7
2.3 GASOLINE REFORMING .....	8
2.3.1 System Requirements .....	8
2.4 ETHANOL TO HYDROGEN .....	8
2.4.1 System Requirements .....	9
2.5 FT DISTILLATE REFORMING .....	10
2.5.1 System Requirements .....	10
2.6 THERMAL CRACKING OF WATER.....	10
2.6.1 Nuclear Power Overview .....	10
2.6.2 Nuclear Power and Thermal Cracking of Water .....	12
2.6.3 Thermal Cracking of Water.....	13
2.7 REFORMER EMISSIONS.....	17
3. HYTHANE® .....	19
3.1 INTRODUCTION .....	19
3.2 LIGHT DUTY VEHICLES.....	19
3.3 HEAVY DUTY VEHICLES .....	20
4. OTHER MODEL UPDATES .....	22
4.1 HYDROGEN TRANSPORTATION .....	22
4.1.1 On Site Generation.....	22
4.1.2 Hydrogen Compression.....	22
4.1.3 Pipeline Transportation.....	22
4.2 LDV AND HDV SUMMARIES.....	22
4.3 COST EFFECTIVENESS.....	23
5. GREENHOUSE GAS RESULTS.....	24
5.1 HYDROGEN PRODUCTION .....	24
5.1.1 Methanol to Hydrogen .....	24
5.1.2 Gasoline Reforming.....	25
5.1.3 Ethanol to Hydrogen.....	26
5.1.4 FT Distillate Reforming.....	27
5.1.5 LPG Reforming.....	28
5.1.6 Thermal Cracking of Water.....	29
5.2 HYTHANE® USE .....	31
5.2.1 Light Duty Vehicles.....	31
5.2.2 Heavy Duty Vehicles .....	32
5.3 SUMMARY GHG EMISSIONS WELL TO TANK.....	32
6. OTHER RESULTS.....	34

6.1 ENERGY EFFICIENCY .....	34
6.2 COST EFFECTIVENESS.....	35
6.3 EMISSIONS SUMMARIES .....	36
7. CONCLUSIONS.....	39
8. REFERENCES .....	40

## TABLE OF TABLES

Table 2-1 Methanol Reformer Operating Requirements .....	6
Table 2-2 Utility Consumption LPG Reformers.....	7
Table 2-3 Utility Consumption Gasoline Reformers.....	8
Table 2-4 Epyx Thermal Conversion Efficiencies .....	9
Table 2-5 Utility Consumption Ethanol Reformers.....	9
Table 2-6 Utility Consumption FT Distillate Reformers .....	10
Table 2-7 Natural Gas Reformer Emission Factors .....	17
Table 2-8 Linde SMR Emission Rates.....	18
Table 2-9 Emission Factors Assumptions .....	18
Table 3-1 Hythane® Results in Light Duty Application .....	20
Table 3-2 Emission Results Hythane® Buses .....	21
Table 5-1 Well to Tank Emissions, Methanol to Hydrogen .....	24
Table 5-2 Well to Wheel Emissions, Methanol to Hydrogen .....	25
Table 5-3 Well to Tank Emissions, Gasoline to Hydrogen.....	25
Table 5-4 Well to Wheel Emissions, Gasoline to Hydrogen.....	26
Table 5-5 Well to Tank Emissions, Ethanol to Hydrogen.....	26
Table 5-6 Well to Wheel Emissions, Ethanol to Hydrogen.....	27
Table 5-7 Well to Tank Emissions, FT Distillate to Hydrogen .....	27
Table 5-8 Well to Wheel Emissions, FT Distillate to Hydrogen .....	28
Table 5-9 Well to Tank Emissions, LPG to Hydrogen.....	28
Table 5-10 Well to Wheel Emissions, LPG to Hydrogen.....	29
Table 5-11 Well to Tank Emissions, Electrolysis from Conventional Nuclear Power.....	29
Table 5-12 Well to Wheel Emissions, Electrolysis from Conventional Nuclear Power .....	30
Table 5-13 Well to Tank Emissions, Nuclear Power and Thermal Cracking .....	30
Table 5-14 Well to Wheel Emissions, Nuclear Power and Thermal Cracking .....	31

Table 5-15 Well to Tank Emissions, Hythane® and CNG.....	31
Table 5-16 LDV Well to Wheel Emissions, Hythane® and CNG.....	32
Table 5-17 HDV Well to Wheel Emissions, Hythane® and CNG .....	32
Table 5-18 GHG Emissions Summary.....	33
Table 6-1 Energy Consumed for Hydrogen Pathways.....	34
Table 6-2 Energy Consumed for Hydrogen Pathways.....	35
Table 6-3 Energy Consumed for CNG and Hythane® Pathways.....	35
Table 6-4 Light-Duty Fuel Cells GHG Cost Effectiveness.....	36
Table 6-5 GHG Emissions Summary, Light Duty Fuel Cell Vehicles .....	37
Table 6-6 Other Emissions Summary, Light Duty Fuel Cell Vehicles.....	38

## TABLE OF FIGURES

Figure 2-1 Methanol to Hydrogen Reformers.....	5
Figure 2-2 LPG Reforming .....	7
Figure 2-3 Nuclear Power Evolution .....	12
Figure 2-4 UT-3 Flow Diagram .....	14
Figure 2-5 Sulphur-Iodine Cycle .....	16





# 1. INTRODUCTION

The Canadian Transportation Fuel Cell Alliance (CTFCA) is a \$23 million federal government initiative that will demonstrate and evaluate fuelling options for fuel cell vehicles in Canada. Different combinations of fuels and fuelling systems will be demonstrated by 2005 - for light, medium and heavy-duty vehicles. The initiative will also develop standards, training, and testing procedures as related to fuel cell and hydrogen technologies.

The Program focuses its efforts on showcasing refueling demonstration projects, evaluating different fuelling routes for light-, medium- and heavy-duty fuel-cell vehicles, monitoring the resulting greenhouse gas emission reductions, and developing the necessary supporting framework for the fuelling infrastructure, including technical codes and standards, training, certification and safety.

The Studies and Assessments Working Group is the research arm of the CTFCA Program. It assists the other working groups by developing a grid to steer their work and produces a compendium of existing technological, socio-economic and environmental studies in the area of fuelling pathways. The Working Group has access to NRCan's in-house model (GHGenius) to run data generated by the demonstration projects. Information from this model is needed to assess emissions performance and costing evaluations of fuelling pathways.

The purpose of this work is to add fuel cycles that may be demonstrated in the CTFCA demonstrations to the model so that an assessment of the projected greenhouse gas benefits before the projects are funded by the CTFCA.

## 1.1 BACKGROUND

The GHGenius greenhouse gas model is based on a model originally developed by Dr. Mark Delucchi in the late 1980's. That original model was partially canadianized by Delucchi in 1998. In 1999, Levelton (1999) further developed the model for Canada for the Transportation Table of the National Climate Change Process. Subsequent to that work Levelton and (S&T)<sup>2</sup> used the model for evaluation of ethanol produced from corn (Levelton, 1999b) and ethanol produced from lignocellulosics (Levelton, 1999c) for projects for Agriculture and Agri-Foods Canada. (S&T)<sup>2</sup> used the model for an evaluation of ethanol production using wheat in Alberta (Cheminfo) and for evaluating various fuel cell cycles for Methanex Corporation ((S&T)<sup>2</sup>, 2000). In 2001 the data from most of these projects was incorporated into a model update, some changes to the structure of the model were made to make it more user friendly and it was renamed GHGenius.

In 2001 Levelton, (S&T)<sup>2</sup>, and Delucchi undertook a major upgrade of the model for Natural Resources Canada. This involved adding more detail to some of the model calculations, adding data for Mexico, expanding the forecast period to 2050 and providing the ability to regionalize the output on a North American basis.

This report accompanies a revised model (Version 2.1) which incorporates the additional fuel cycles for hydrogen production off board a vehicle and the use of mixtures of hydrogen and natural gas in engines.

The GHGenius model is capable of estimating full fuel cycle emissions of the primary greenhouse gases, carbon dioxide, methane, nitrous oxide, and the criteria pollutants, nitrogen oxides, carbon monoxide, sulphur oxides, non-methane organic compounds (also known as VOC's) and total particulate matter from combustion sources.

The fuel cycle model predicts emissions for past, present and future years using historical data or correlations for changes in energy and process parameters with time that are stored in the model. The fuel cycle segments considered in the model are as follows:

- Vehicle operation;
- Fuel dispensing at the retail level;
- Fuel storage and distribution at all stages;
- Fuel production (as in production from raw materials);
- Feedstock transport (including imported crude oil);
- Feedstock production and fertilizer production (the latter is included only where fertilizer is associated with fuel production);
- Land use changes and cultivation associated with biomass derived fuels;
- Leaks and flaring of greenhouse gases associated with production;
- Emissions displaced by co-products of alternative fuels;
- Vehicle assembly and transport;
- Materials used in the vehicles.

The model uses the IPCC guidelines for weighting the emissions of the greenhouse gases. Carbon dioxide has a weighting of 1.0, methane is assigned a value of 21.0, and nitrous oxide has a weighting factor of 310.

## 1.2 STUDY OBJECTIVES

The objective of this work is to add the following fuel cycles;

1. Off board reforming of methanol. This process is commercially available and manufacturer specifications have been used for modeling purposes. It has been assumed that these are decentralized facilities.
2. Off board reforming of gasoline. This process has been discussed but it is not yet commercial. Data from commercial naphtha reformers and experimental data will be used for the modeling base line. The facilities will be decentralized.
3. Off board reforming of ethanol. Similar to gasoline in approach. The ethanol can be produced from either corn or cellulose. Both ethanol cycles have been added to the model.
4. Off board reforming of Fischer Tropsch distillate. Similar in approach to ethanol and gasoline.
5. The use of nuclear energy to thermally crack water. Large centralized plants with distribution to service stations. This new approach to producing hydrogen is being discussed in the US and in Japan. Data from the discussion papers will be used for modeling. The interesting output from this cycle is a comparison to using nuclear power to produce electricity and then hydrogen from electrolysis.
6. The off board reforming of LPG. LPG is being considered for stationary fuel cell applications and by modeling it here in a decentralized system, it will be possible to compare the results to some of the other fuels being proposed for stationary systems.

For each fuel cycle the hydrogen will be used for both light duty and heavy duty applications so the full cycle results for sheets AC, AD, Cost LDV, Cost HDV, Summary LDV, and Summary HDV include both light duty and heavy duty results. Sheets K and I have been modified to include the new fuel cycles. The energy efficiency of the fuel cycles have been added to sheet I (except for the nuclear cycle) and all of the cycles have been added to sheet K for the emissions up to the dispensing nozzle.

Hythane® (a mixture of hydrogen and natural gas) has been added to the model as it has been discussed as a possible way of increasing the demand for hydrogen before fuel cell vehicles being commercially available. Hythane® compositions between 0 and 60% hydrogen for both light duty vehicles and heavy-duty vehicles have been added. The hydrogen is either from electrolysis or from steam methane reforming at the option of the user. The sheets of the model that have been changed for Hythane® include Sheets C, H, I, K, AC, AD, Cost LDV and HDV, and Summary LDV and HDV.

## 2. HYDROGEN PRODUCTION CYCLES

Hydrogen can be produced by a variety of methods. The most common are through electrolysis of water and through the steam reforming of natural gas. Both of these routes are currently found in the GHGenius model. As the interest in hydrogen as a transportation fuel grows, more pathways are being suggested for the production of hydrogen. Some of these pathways are commercially practiced in industrial settings and others are at the experimental stage. In this section six new hydrogen pathways are described. Two of these, methanol to hydrogen and LPG to hydrogen are commercially practiced for industrial applications. Actual performance data is described for these cycles. Variations of two of the pathways, gasoline (naphtha) and FT distillate (heavy oil), are used in industrial applications and here the data has been adapted for modeling purposes. The other two pathways, ethanol to hydrogen and the thermal cracking of water are more experimental and less real data is available.

### 2.1 METHANOL TO HYDROGEN

Methanol can be reformed to hydrogen and carbon dioxide at relatively low temperatures of about 300 C. This lower temperature offers a distinct advantage over reforming natural gas. Low temperature operation permits for fast start up, a simplified process flow and the use of inexpensive materials of construction. The systems have higher efficiencies, typically on the order of 80% compared to the 67 to 70% efficiency of steam methane reforming units.

There are a number of manufacturers of these systems. In Germany, Caloric Analgenbau GmbH, and Mahler AGS GmbH both manufacturer hydrogen production units using methanol decomposition. Other European companies with systems include Axsia Howmar Hydrogen Division, an English company and Haldor Topsoe a Danish company. In the United States Hydro Chem, a subsidiary of Linde, produces systems produce packaged systems. All of these manufacturers also produce hydrogen units based on SMR of methane.

There is a trade-off between capital cost advantages and higher operating costs which results in methanol decomposition units being more cost effective at small scales and losing that advantage to SMR when the size of the units increases. The manufacturers offer units in the size range of 50 to 4000 Nm<sup>3</sup>/hr (200 to 8000 kg/day). This size range is quite well suited to transportation applications.

Methanol decomposition is regularly used to provide hydrogen for industrial applications such as hydrogenation of edible oils and fatty acids and in the manufacture of electronic components and plate glass.

The basic process of methanol decomposition, in Figure 2-1, consists of the following steps:

- Mixing of methanol and demineralized water.
- Preheating and evaporation of the methanol/water mixture.
- Methanol decomposition and shift conversion.
- Process gas cooling and condensate separation.
- Purification in PSA unit.

This is sometimes incorrectly referred to as steam reforming of methanol. It differs from the other steam reforming processes described later by not requiring steam for the first step in the process. The steam or water is only required for the water gas shift of carbon monoxide to hydrogen.

**Figure 2-1 Methanol to Hydrogen Reformers**

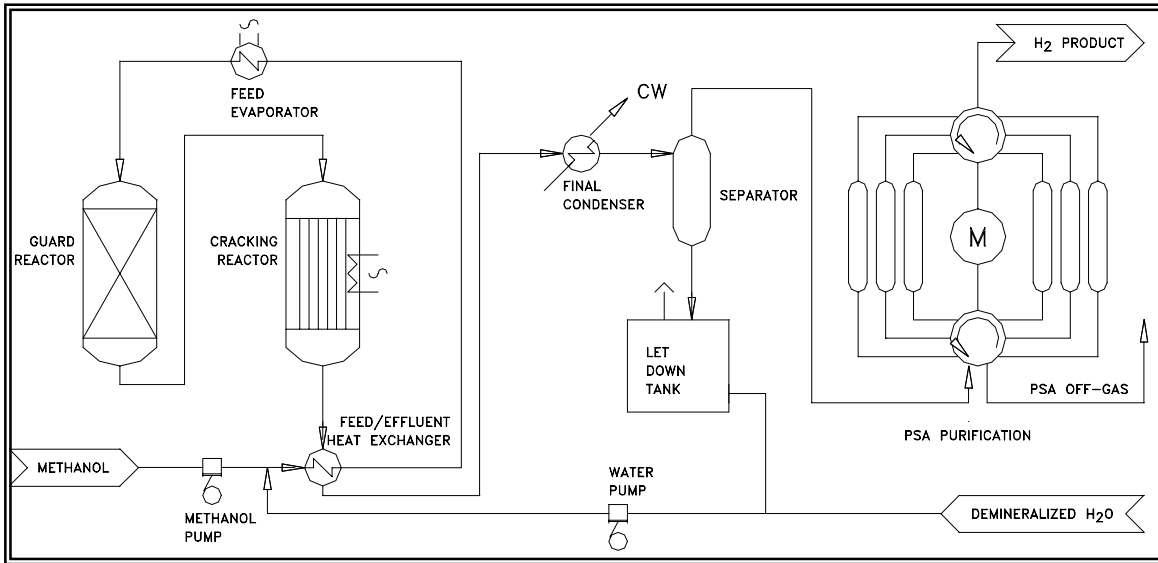

Methanol and demineralized water are pumped to 21 bar(g) pressure and automatically mixed to the required ratio. The mixture is heated in the feed/effluent heat exchanger and vapourized in a heater. The methanol/water vapour is then sent to the decomposition reactor. Here the gas is passed over catalysts, which simultaneously catalyze the following reactions:

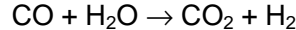
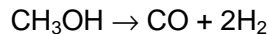

The overall reaction is endothermic, and the necessary heat is conveyed by means of either electric heating coils installed in the reactor block for small systems or from the combustion of methanol and PSA purge gases in larger systems.

The catalysts are arranged in a guard layer, absorbing any S and Cl contaminants in the feedstock, and in a number of catalyst tubes.

The gas is cooled in the feed/effluent heat exchanger and a water-cooler. The condensate is separated from the gas.

The hydrogen is subsequently purified in a PSA unit operating with a hydrogen recovery rate of approx. 78%. The PSA off-gas can be vented, or used as fuel outside the hydrogen unit.

The production rate is controlled by the pressure in the supply line through automatic control of the feed pump, and the whole operation is monitored by a PLC system.

### 2.1.1 System Requirements

For systems up to 150 NM<sup>3</sup>/hr (325 kg/day) the PSA purge gases are catalytically combusted to supply the required energy and they are electrically heated for the remainder of the energy requirements. The larger systems up to 3,000 NM<sup>3</sup>/hr (6500 kg/day) are fueled by the PSA purge gases and methanol. The operating parameters are shown in Table 2-1 for typical systems. The larger system has been used as the basis of the modeling. The methanol fuel could also be supplied by other energy sources such as natural gas depending on the site requirements.

**Table 2-1 Methanol Reformer Operating Requirements**

	<b>Methanol Feed</b>	<b>Methanol Fuel</b>	<b>Electric Power</b>	<b>Cooling Water</b>
	Kg/NM <sup>3</sup> H <sub>2</sub>	Kg/NM <sup>3</sup> H <sub>2</sub>	kWh/NM <sup>3</sup> H <sub>2</sub>	litres/ NM <sup>3</sup> H <sub>2</sub>
Small Systems	0.67	0	0.45	20
Large Systems	0.63	0.06	0.06	20
	USG/million BTU	USG/million BTU	kWh/million BTU	USG/million BTU
Small Systems	18.57	0	37.25	1,655
Large Systems	17.46	1.66	4.97	1,655

The systems offered by different suppliers are quite close in their performance especially for the larger systems. The input values shown above have been set as the default values on the input sheet. The methanol input is the sum of the methanol feed and methanol fuel values.

## 2.2 LPG REFORMING

LPG (propane) can be steam reformed to hydrogen in much the same as methane can be reformed. Relatively small-scale systems (50-400 NM<sup>3</sup>/hr) have been built by companies such as Mahler, Caloric, Haldor Topsoe, and Hydro-chem. These systems are ideally sized for the expected hydrogen loads of a typical service station in a mature marketplace.

LPG is preheated to about 380C before passing through a cobalt molybdenum catalyst and zinc oxide bed to desulphurize the gas. Steam is mixed with this gas, preheated to 480C and introduced in to a nickel catalyst reformer to produce carbon monoxide and hydrogen (first reaction). The gas leaves the reactor at 800C and is then cooled to approximately 350C and introduced into a second reactor (iron catalyst) to convert the carbon monoxide and steam to more hydrogen and carbon dioxide (second reaction). The gas is finally purified to 99.9995% hydrogen in a pressure swing absorption unit. Note that unlike the methanol decomposition systems the two reactions occur at different temperatures and in different reactors. The process is shown in Figure 2-2.

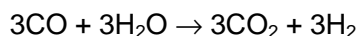
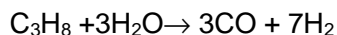

The overall reaction becomes;

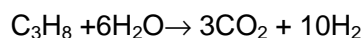

**Figure 2-2 LPG Reforming**

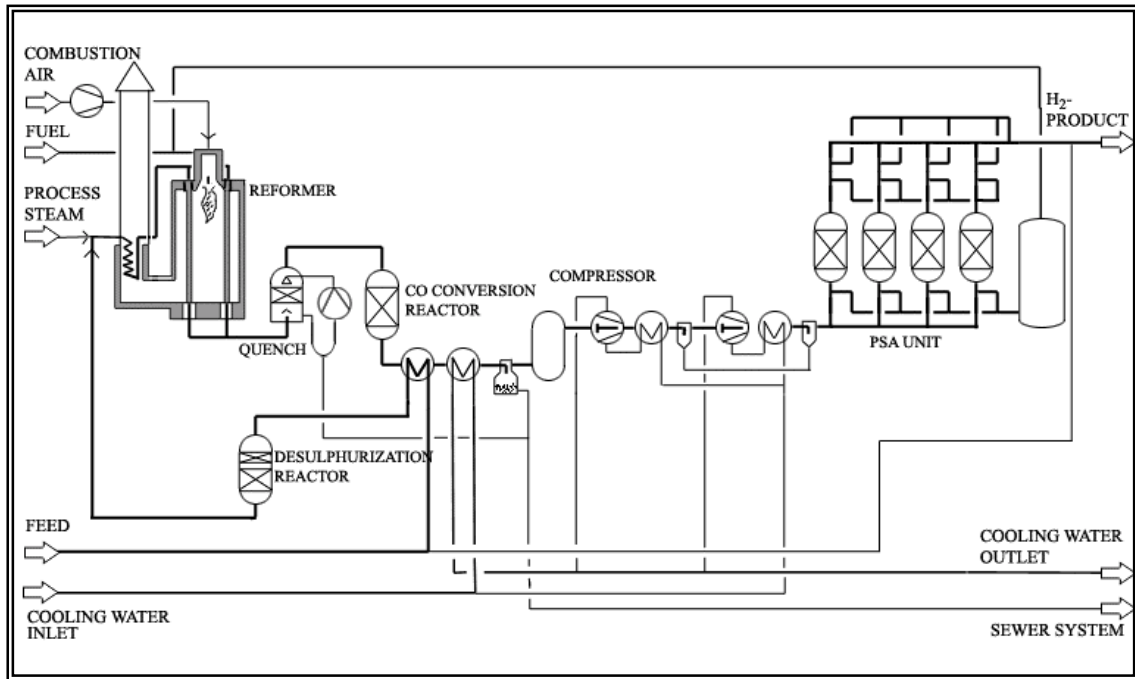

**2.2.1 System Requirements**

The utility consumption of a unit manufactured by Mahler is shown in the following table. These are the default values in the model. It is assumed that the steam required for the process is produced from the combustion of propane at an efficiency of 80%. In this system, the PSA purge gas is recycled to the fuel inlet of the reformer furnace.

**Table 2-2 Utility Consumption LPG Reformers**

Input	Consumption	Consumption
LPG	0.40 kg/NM <sup>3</sup>	17.26 USG/million BTU
LPG for steam	0.081 kg/NM <sup>3</sup>	3.50 USG/million BTU
Electricity	0.32 kWh/NM <sup>3</sup>	26.5 kWh/million BTU
Cooling water	100 litres/NM <sup>3</sup>	2190 USG/million BTU

The values in the previous table have been used as the default values on the input sheet. Some of the manufacturers offer different versions of their SMR systems depending on the customer requirements. There are versions available that require less energy and thus have lower GHG emissions. These systems have a higher cost. There are also systems that can co-produce steam along with the hydrogen. This co-production has not been modeled since there may not be very many opportunities for this in transportation type applications. These options are available for all of the SMR systems irrespective of the fuel.

There are alternatives to steam methane reforming that could be used to produce hydrogen such as auto thermal reactors (ATR) and partial oxidation reactors (POX). Both of these systems introduce some oxygen or air into the first reactor. The GHGenius model will correctly calculate

the greenhouse gas emissions for these systems as well when the appropriate inputs of fuel, process gas and electricity are used.

### 2.3 GASOLINE REFORMING

Gasoline reformers are being developed for use on board fuel cell vehicles. Gasoline could also be reformed at a service station and compressed hydrogen dispensed to the vehicle. Gasoline reformers are not commercially available but several manufacturers of hydrogen production systems do offer naphtha systems. These systems have been sold by Mahler, Caloric, Haldor Topsoe and Hydro Chem.

Naphtha reformers operate essentially the same as LPG reformers with similar catalysts and temperatures. It is assumed that gasoline would be reformed in a similar manner. If octane (C<sub>8</sub>H<sub>18</sub>) is a surrogate for gasoline then the reactions are as follows.

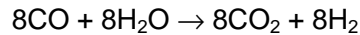
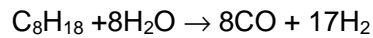

The overall reaction is;

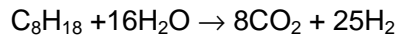

#### 2.3.1 System Requirements

The utility consumption of a unit is estimated from the requirements of a Mahler naphtha reforming system and is shown in the following table. These are the default values in the model. It is assumed that the steam required for the process is produced from the combustion of gasoline at an efficiency of 80%. In this system, the PSA purge gas is recycled to the fuel inlet of the reformer furnace.

**Table 2-3 Utility Consumption Gasoline Reformers**

Input	Consumption	Consumption
Gasoline	0.42 kg/NM <sup>3</sup>	12.43 USG/million BTU
Gasoline for steam	0.093 kg/NM <sup>3</sup>	2.75 USG/million BTU
Electricity	0.33 kWh/NM <sup>3</sup>	27.3 kWh/million BTU
Cooling water	105 litres/NM <sup>3</sup>	2300 USG/million BTU

### 2.4 ETHANOL TO HYDROGEN

Ethanol is not reformed to hydrogen commercially. It has been used in some of the US DOE research programs developing multi-fuel reformers and a 15 kW stationary fuel cell system is under development with the project partners announced they have recently completed the design phase. Caterpillar, Inc., Nuvera Fuel Cells, Inc., and Williams Bio-Energy have teamed up to design, build, and operate a 13 kilowatt stationary fuel cell that will be powered by hydrogen derived from ethanol (RFA).

The likely reasons for no commercial hydrogen production from ethanol relates to the fact that it is traditionally a more expensive feedstock than methanol, methane or LPG and it is more technically challenging. Although ethanol and methanol both are alcohols, there is a great difference in their chemical behavior. Ethanol will, instead of decomposing, dehydrate into the



unsaturated chemical ethylene which needs to be saturated (requiring the consumption of hydrogen) turning into ethane which then can be reformed and produce hydrogen.

The ethanol steam reforming reactions are summarized below.

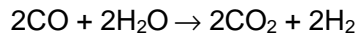
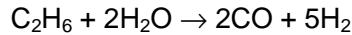
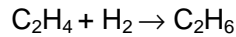
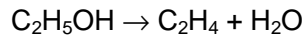

The overall reaction is therefore:

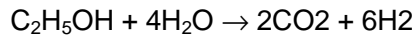

Ethanol reforms at lower temperatures than methane or LPG but higher temperatures than methanol. The Nuvera ethanol system uses an auto thermal reactor.

#### 2.4.1 System Requirements

The system requirements for a stationary ethanol to hydrogen system have been estimated so that the overall system efficiency is in line with reported by Epyx (a Nuvera predecessor company) to the US DOE (US DOE 1999). The reported system efficiencies are shown in the following table for various fuels. From the efficiency for ethanol, the utility consumption in Table 2-5 has been calculated. These values are used as the default values in the model.

**Table 2-4 Epyx Thermal Conversion Efficiencies**

Fuel	Steady State System Efficiency
Natural Gas	84%
Gasoline	77%
Methanol	89%
Ethanol	84%
Fischer Tropsch Distillate	79%

**Table 2-5 Utility Consumption Ethanol Reformers**

Input	Consumption	Consumption
Ethanol	0.61 kg/NM <sup>3</sup>	16.91 USG/million BTU
Ethanol for steam	0.12 kg/NM <sup>3</sup>	3.75 USG/million BTU
Electricity	0.30 kWh/NM <sup>3</sup>	25 kWh/million BTU
Cooling water	100 litres/NM <sup>3</sup>	2190 USG/million BTU

## 2.5 FT DISTILLATE REFORMING

Distillates and heavy fuel oils have been successfully used as feedstocks for hydrogen production plants in oil refineries and similar facilities. Approximately 30% of the world's production of hydrogen is derived from petroleum feedstocks.

Fischer Tropsch distillates are attractive fuels for reforming since they are sulphur free and have a rather narrow composition range. Experiments with reforming these fuels have been performed by Syntroleum Corporation. Much of this work has been on a naphtha type material that would be similar to the gasoline step modeled. Very little actual data is available.

### 2.5.1 System Requirements

Based on the performance data from the Epyx auto thermal reactor the system requirements for a FT distillate have been estimated. The assumptions are shown in the following table and they have been used as the default values.

**Table 2-6 Utility Consumption FT Distillate Reformers**

Input	Consumption	Consumption
FT Distillate	0.41 kg/NM <sup>3</sup>	11.57 USG/million BTU
FT Distillate for steam	0.08 kg/NM <sup>3</sup>	2.56 USG/million BTU
Electricity	0.31 kWh/NM <sup>3</sup>	26.6 kWh/million BTU
Cooling water	100 litres/NM <sup>3</sup>	2190 USG/million BTU

## 2.6 THERMAL CRACKING OF WATER

The concept being proposed for thermally cracking water is to use a new generation of nuclear reactors to provide the thermal energy required to crack water into hydrogen and oxygen. This process is at a very early stage of development and it is only possible to model the process by making a number of broad assumptions about the performance expected from these systems and comparing that to the current nuclear power systems.

The GHGenius model does not include the CANDU reactor cycle but rather it models the light water cycles typically found in US nuclear systems. GHG emissions from both reactors are relatively minor. The CANDU reactors do not require enriched uranium but do require heavy water. Andseta et al calculated carbon dioxide emissions for the CANDU cycle to be 937 gms/million BTU of power (including construction and decommissioning). This is quite similar to the 744 gms/million BTU in the model.

### 2.6.1 Nuclear Power Overview

To provide the power for an electric generator, nuclear power plants rely on the process of nuclear fission. In this process, the nucleus of uranium splits when bombarded by a free neutron in a nuclear reactor. The fission process for uranium atoms yields two smaller atoms, one to three free neutrons, plus an amount of energy. Because more free neutrons are released from a uranium fission event than are required to initiate the event, the reaction can become self-sustaining--a chain reaction--under controlled conditions, thus producing a tremendous amount of energy.

In the vast majority of the world's nuclear power plants, heat energy generated by burning uranium fuel is collected in ordinary water and is carried away from the reactor's core either as steam in boiling water reactors or as superheated water in pressurized-water reactors. In a pressurized-water reactor, the superheated water in the primary cooling loop is used to transfer heat energy to a secondary loop for the creation of steam. In either a boiling-water or pressurized-water installation, steam under high pressure is the medium used to transfer the nuclear reactor's heat energy to a turbine that mechanically turns an electric generator. Boiling-water and pressurized-water reactors are called light-water reactors, because they utilize ordinary water to transfer the heat energy from reactor to turbine in the electricity generation process. In other reactor designs, such as the CANDU reactor, the heat energy is transferred by pressurized heavy water, gas, or another cooling substance.

The conversion of this heat energy to electrical power is about 33% in the current light water reactors (EIA). This conversion efficiency is important for the modeling since the greenhouse gas emissions are primarily from the uranium mining, milling and enrichment as described below.

Uranium ore is extracted through conventional mining in open pit and underground methods similar to those used for mining other metals. *In situ* leach mining methods also are used to mine uranium in the United States. In this technology, uranium is leached from the in-place ore through an array of regularly spaced wells and is then recovered from the leach solution at a surface plant. Uranium ores in the United States typically range from about 0.05 to 0.3 percent uranium oxide ( $U_3O_8$ ). Some uranium deposits developed in other countries are of higher grade and are also larger than deposits mined in the United States.

Mined uranium ores normally are processed by grinding the ore materials to a uniform particle size and then treating the ore to extract the uranium by chemical leaching. The milling process commonly yields dry powder-form material consisting of natural uranium, "yellowcake," which is sold on the uranium market as  $U_3O_8$ .

Milled uranium oxide,  $U_3O_8$ , must be converted to uranium hexafluoride, UF<sub>6</sub>, which is the form required by most commercial uranium enrichment facilities currently in use. A solid at room temperature, UF<sub>6</sub> can be changed to a gaseous form at moderately higher temperatures. The UF<sub>6</sub> conversion product contains only natural, not enriched, uranium.

The concentration of the fissionable isotope, <sup>235</sup>U (0.71 percent in natural uranium) is less than that required to sustain a nuclear chain reaction in light water reactor cores. Natural UF<sub>6</sub> thus must be "enriched" in the fissionable isotope for it to be used as nuclear fuel. The different levels of enrichment required for a particular nuclear fuel application are specified by the customer: light-water reactor fuel normally is enriched up to about 4 percent <sup>235</sup>U, but uranium enriched to lower concentrations also is required. Gaseous diffusion and gas centrifuge are the commonly used uranium enrichment technologies. The gaseous diffusion process consists of passing the natural UF<sub>6</sub> gas feed under high pressure through a series of diffusion barriers (semi-porous membranes) that permit passage of the lighter <sup>235</sup>UF<sub>6</sub> atoms at a faster rate than the heavier <sup>238</sup>UF<sub>6</sub> atoms. This differential treatment, applied across a large number of diffusion "stages," progressively raises the product stream concentration of <sup>235</sup>U relative to <sup>238</sup>U. In the gaseous diffusion technology, the separation achieved per diffusion stage is relatively low, and a large number of stages are required to achieve the desired level of isotope enrichment. Because this technology requires a large capital outlay for facilities and it consumes large amounts of electrical energy, it is relatively cost intensive. In the gas centrifuge process, the natural UF<sub>6</sub> gas is spun at high speed in a series of cylinders. This acts to separate the <sup>235</sup>UF<sub>6</sub> and <sup>238</sup>UF<sub>6</sub> atoms based on their slightly different atomic masses. Gas centrifuge technology involves relatively high capital costs for the specialized equipment required, but its power costs are below those for the gaseous diffusion technology.

In the GHGenius model, all of the above factors are used in determining the GHG emissions for nuclear power. A mix of upgrading methods is used in the model depending on where the uranium is upgraded. There are also emissions calculated from standby diesel generators which are used to operate emergency cooling water pumps, a small amount of natural gas used at the power plants and the emissions from the transportation of the uranium.

### 2.6.2 Nuclear Power and Thermal Cracking of Water

The United States plans to develop a comprehensive technology roadmap that defines paths to two types of advanced nuclear technology systems:

- Advanced "Generation III+" systems that can be deployed before the end of the decade (*i.e.*, by 2010).
- Generation IV systems that can be deployed by 2030.

The anticipated evolution of nuclear power is shown in the following figure.

**Figure 2-3 Nuclear Power Evolution**

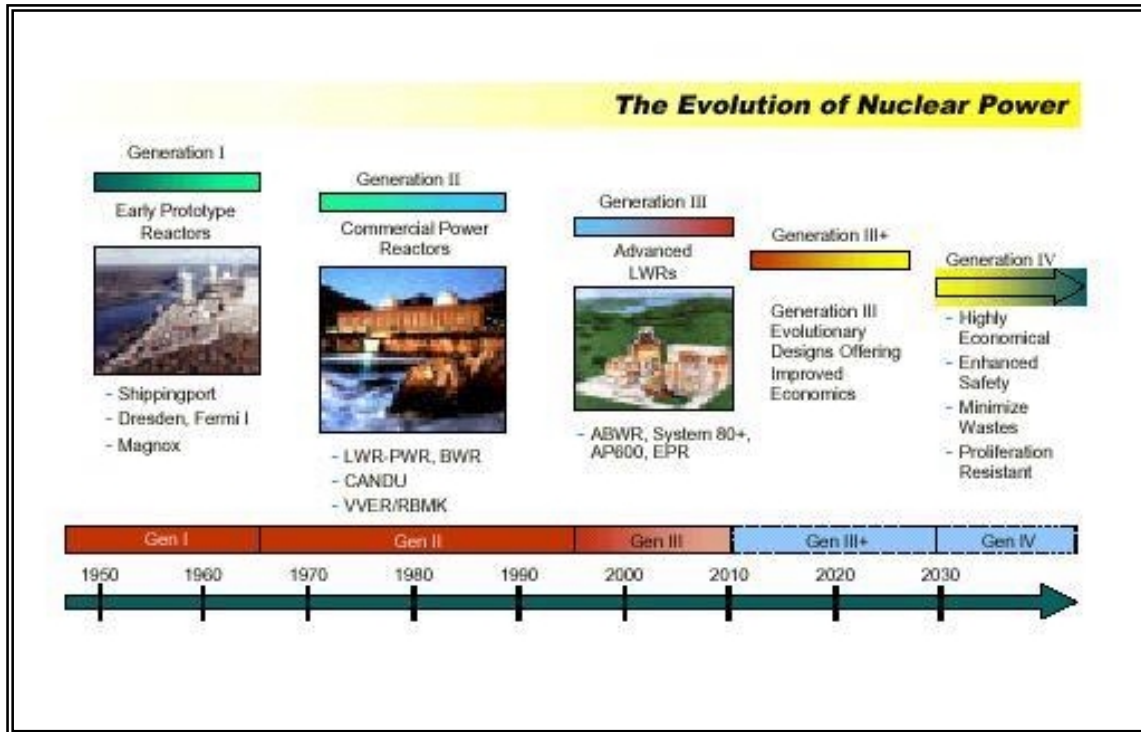

Generation III and Generation III+ technologies, largely made up of advanced water-cooled reactors and some advanced gas reactor technologies, are already competitive in many parts of the world today. The US Department of Energy, and representatives of other countries are supporting a study program to build on their past nuclear experience in order to identify, research and begin a fourth generation (Generation IV) of nuclear energy systems. The eight goals of the Generation IV systems are:

- Provide sustainable energy generation that meets clean air objectives and promotes long term availability of systems and effective fuel utilization for worldwide energy production.
- Minimize and manage nuclear waste and notably reduce the long-term stewardship burden in the future, thereby improving protection for the public health and the environment.
- Increase the assurance that they are the very unattractive and least desirable routes for diversion or theft of weapons-usable materials.
- Excel in safety and reliability.
- Have a very low likelihood and degree of reactor core damage.
- Eliminate the need for offsite emergency response.
- Have a clear life cycle cost advantage over other energy sources.
- Have a level of financial risk comparable to other energy projects.

The concept for hydrogen production is that a Generation IV reactor is modified to heat helium or another heat transport gas to a high temperature which can be used in a water cracking cycle, thus producing hydrogen for power production and oxygen for industrial uses. The "waste" heat from this process can be applied as process heat for industry, district heating or desalination purposes.

The Generation IV-H2 program is a US DOE project and has multiple participants, including Argonne, Texas A&M University, General Electric and international collaborators.

### 2.6.3 Thermal Cracking of Water

Thermochemical water splitting processes have been studied for the past 35 years (Besenbruch, et al). They were extensively studied in the 1970's and 80's but have not received much attention for the past ten years. There have been over 100 cycles proposed but substantial research has been undertaken on only a few. In 1999 General Atomics in collaboration with the University of Kentucky and Sandia National Laboratories undertook an exhaustive literature search to identify all of the cycles previously proposed and then screened them to determine which of the cycles could benefit in terms of efficiency and cost from high temperatures advanced reactors. Two cycles were selected from this screening process, the adiabatic UT-3 cycle invented at the University of Tokyo and the sulphur-iodine cycle. These two cycles are briefly described below.

#### 2.6.3.1 UT-3 Cycle

The basic reactions of this cycle are as follows:

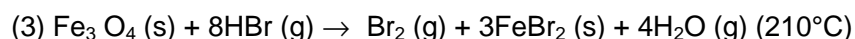
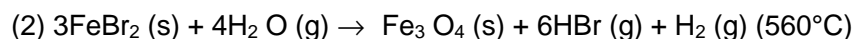
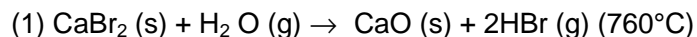

Besenbruch described the UT-3 cycle as follows.

*The basic UT-3 cycle was first described at University of Tokyo in the late 1970s and essentially all work on the cycle has been performed in Japan. Over time the flow sheet has undergone several revisions — the most recent, based on the adiabatic implementation of the cycle, was published in 1996. A simplified flow diagram of the*

Adiabatic UT-3 cycle matched to a nuclear reactor is shown in the following figure. The four chemical reactions take place in four adiabatic fixed, packed bed chemical reactors that contain the solid reactants and products. The chemical reactors occur in pairs — one pair contains the calcium compounds and the other pair the iron compounds. The nuclear reactor transfers heat through a secondary heat exchanger into the gas stream which traverses through the four chemical reactors, three process heat exchangers, two membrane separators and the recycle compressor in sequence before the gases are recycled to the reactor secondary heat exchanger.

Figure 2-4 UT-3 Flow Diagram

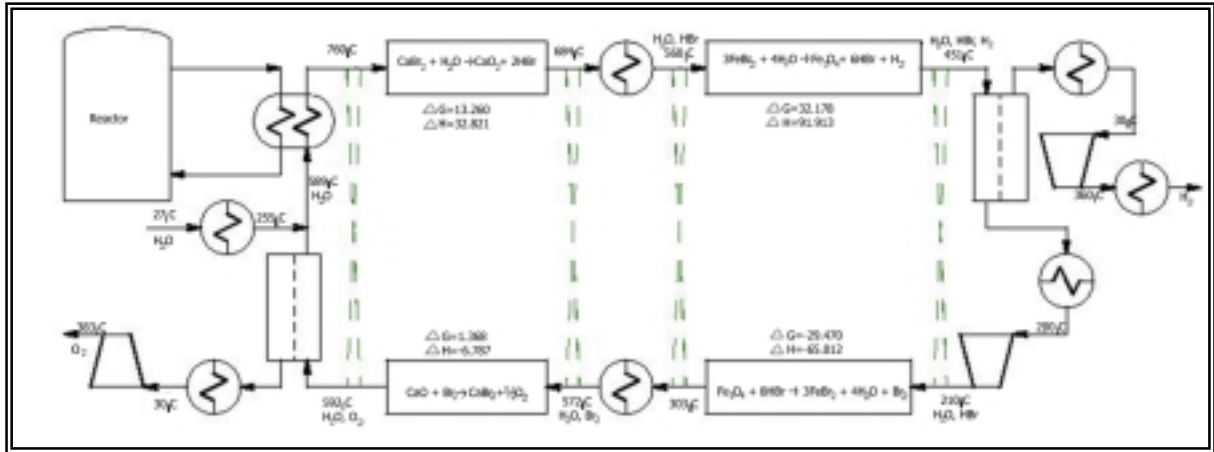

At each chemical reactor, the gaseous reactant passes through the bed of solid product until it reaches the reaction front where it is consumed creating gaseous product and solid product. The gaseous product traverses through the unreacted solid and exits the chemical reactor. After some time, perhaps an hour, the reaction front has traveled from near the entrance of the reactor to near the exit. At this point, the flow paths are switched and chemical reactors, in each pair, switch functions. The direction of flow through the reactor also switches so that the reaction front reverses direction and travels back toward the end that had previously been the entrance. The direction must be switched before the reaction front reaches the end of a reactor to prevent large temperature swings but it is desirable for the reaction front to approach the ends of the reactor to reduce the frequency of flow switching.

The gas stream is conditioned, either heated or cooled, before entering the chemical reactor. Since the gaseous reactant/product cannot carry sufficient heat to accomplish the reaction, a large quantity of inert material (steam) comprises the majority of the stream. The total stream pressure is 20 atmosphere and the minimum steam pressure is 18.5 atmosphere. The inert flow provides the additional function of sweeping the products away from the reaction front and thus shifting the reaction equilibrium towards completion. This is necessary since the Gibbs-free energy is positive for some of the reactions.

The operation of the semi-permeable membranes is somewhat more involved than shown. The partial pressure of hydrogen and oxygen are 0.2 and 0.1 atmosphere respectively. Each gas must be substantially removed from its stream so counter-current operation of the permeator is necessary. This is accomplished by flowing steam past the

backside of the membrane. The steam is condensed and separated from the product gas before the product gas is compressed.

The efficiency of hydrogen generation, for a stand-alone plant, is predicted to be 36% to 40%, depending upon the efficiency of the membrane separation processes. Higher overall efficiencies, 45% to 49%, are predicted for a plant that co-generates both hydrogen and electricity. It is not evident from the published reports if these numbers are based on steady operation or if they take into account the additional inefficiencies associated with the transient operation which occurs when the flow paths are switched.

### 2.6.3.2 Sulphur-Iodine Cycle

The reactions for this cycle are shown below;

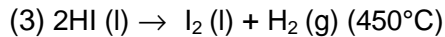
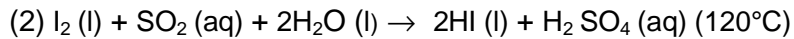
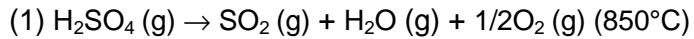

Besenbruch described the Sulphur-Iodine cycle as follows.

The sulfur-iodine cycle was first described in the mid 1970s. It was rejected by early workers due to difficulties encountered separating the hydrogen iodide and sulfuric acid produced in reaction 2. Attempts to use distillation were futile as sulfuric acid and hydrogen iodide react according to the reverse of reaction 2 when their mixture is heated. The key to successful implementation of the cycle was the recognition that using an excess of molten iodine would result in a two-phase solution, a light phase containing sulfuric acid and a heavy phase containing hydrogen iodide and iodine. The following figure shows a block flow diagram of the cycle based on this separation. Several investigators have studied the sulfur-iodine cycle and while the process as a whole is well defined, there is some uncertainty about the best way of accomplishing the hydrogen iodide decomposition step.

Figure 2-5 Sulphur-Iodine Cycle

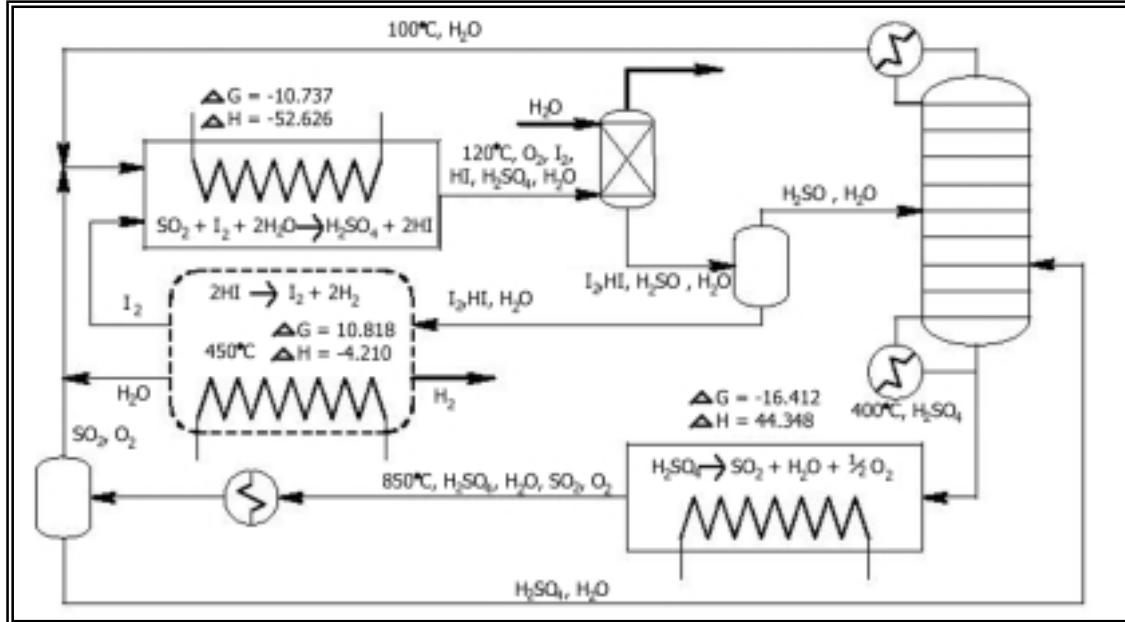

All the early work on the cycle assumed it was necessary to separate the hydrogen iodide from the iodine and water of the heavy phase before performing reaction 3 to generate hydrogen. Bench scale experiments were made of the total process and the process was matched to a high-temperature nuclear reactor in 1978 and 1980. The latter flow sheet, which was optimized for maximum efficiency, indicated that hydrogen could be produced at 52% efficiency. This is the highest efficiency reported for any water-splitting process based on an integrated flow sheet.

Subsequent to the cessation of development of the sulfur-iodine process in the U.S., other workers have made several attempts to improve the efficiency of the cycle by modifying the hydrogen production section of the cycle. In particular, researchers at the University of Aachen demonstrated experimentally that the hydrogen iodide need not be separated from iodine before the decomposition step. Based on their work, they predicted significant increases in efficiency and a 40% decrease in the cost of hydrogen compared with the standard flow sheet. The cost decreases not only because the efficiency increased, but also because the capital-intensive heavy phase separation was eliminated. These proposed improvements have never been incorporated into an integrated flow sheet of the sulfur-iodine hydrogen process with a nuclear reactor.

The Sulfur-Iodine cycle should be matched to a nuclear reactor, incorporating the latest information and thinking. It is the cycle that is almost always used as the standard of comparison as to what can be done with a thermochemical cycle. It was the cycle chosen by LLNL in their conceptual design of a plant to produce synthetic fuels from fusion energy. The Japanese consider the sulfur-iodine cycle to be a backup for the UT-3 cycle and continue chemical investigations although they have not published any flow sheets matching the cycle to a nuclear reactor. The cycle has never been matched to a nuclear reactor considering co-generation of electricity. The Japanese found that co-generation gave a 10% efficiency improvement (40% to 50%) for the Adiabatic UT-3 process. If similar improvements are found with the sulfur-iodine cycle, and considering



*the improvements projected by the University of Aachen, the sulfur-iodine cycle could co-produce hydrogen and electricity at over 60% efficiency.*

### 2.6.3.3 Modeling Thermal Cracking of Water

These systems, if they are built, will be large centralized producers of hydrogen. There will be greenhouse gas emissions associated with the production and transportation of uranium and emissions associated with the liquefaction or compression of the hydrogen and its distribution.

The emissions from the uranium part of the cycle are calculated based on the relative efficiency of these cycles versus the 33% efficiency of existing plants converting steam to electricity. Since both of these cycles are projected to have a higher efficiency, these emissions will be lower. The efficiency of these systems is chosen on the input sheet.

The emissions associated with the hydrogen processing and distribution are calculated the same as the other hydrogen cycles in the model except that only centralized production is allowed.

## 2.7 REFORMER EMISSIONS

In order to properly model the hydrogen fuel cycles it is necessary to estimate the emissions of criteria air contaminants from the reformer systems. The natural gas to hydrogen cycle was already included in the model but emission factors for the other reformers had to be estimated. This provided the opportunity to compare the existing model assumptions with those made by others.

In the GREET model these emissions are assumed to be the same as those from an industrial natural gas boiler. A similar approach was used by Spath and Mann. Contadini et al (2000) compared the emission factors for some of the contaminants from a number of studies. Contadini (1999) also published his own estimates based on modeling work done at the University of California at Davis. All of these emission factors are compared in the following table.

**Table 2-7 Natural Gas Reformer Emission Factors**

Emissions g/million BTU	Delucchi	Spath	Greet	Contadini
Fuel Evaporation	10.0	-	-	-
NMOC Exhaust	0.2	-	2.9	-
Methane	0.4	0	1.2	-
Carbon Monoxide	3.0	0.8	44	14.6
Nitrous Oxide	0.5	0	1.2	0.007
NOx	20.0	8.5	16.8	12.3
SOx	0.1	0	0.3	-
PM	0.1	0.2	4.0	-

Some of the differences in these emissions can be explained by different assumptions, Spath for example assumes that low NOx burners will be used in reformers. The Delucchi values tend to be mid range for most contaminants. Linde (1992) reported emission rates for a large natural gas steam reformer. These are shown in the following table. The methane and carbon monoxide emissions are much higher than Delucchi's assumption.

**Table 2-8 Linde SMR Emission Rates**

Contaminant	Emissions, g/million BTU input
Methane	15
Carbon Monoxide	21
NOx	22
SOx	0

Several other references were found for NOx and other contaminants for hydrogen production systems and for natural gas fired heaters. The NPRA filed comments to the US EPA on Best Available Control Technology (BACT) for petroleum refineries as part of the low sulphur gasoline rulemaking process. They reported that NOx emissions for uncontrolled NOx emissions were 45 to 60 gms per million BTU and that the use of low NOx burners could reduce that to 20 to 30 gms/million BTU. Some new refinery hydrogen systems have been designed with further NOx control strategies such as SCR or Urea injection but these are not likely to be employed on the small-scale systems.

Other emissions from hydrogen reformer systems were found in the US EPA BACT database and in the California BACT database. Particulate emissions for a naphtha reformer at a California refinery were 3.4 gm/million BTU and carbon monoxide emissions ranged from 4 to 12 gm/million BTU based on the fuel and the system.

The fuels being used for the hydrogen production systems do not all have the same combustion properties as natural gas so different emissions factors have been applied to the model. The emission factors used in the model are shown in the following table. The NOx emissions have been increase by 50% over natural gas emission rates for LPG, gasoline and FT Distillate based on the EPA AP-42 guidelines for LPG combustion. These emissions are reduced by 50% for methanol based on the much lower temperatures required for methanol decomposition compared to natural gas reforming. The ethanol emission factors are assumed the same as natural gas. Sulphur emissions are higher for propane because of the sulphur content of the fuel and particulate emissions are assumed to be higher for the liquid hydrocarbon fuels due to their more complex molecular structures. An advanced user of the model could make changes to the model on Sheet N, rows 8 to 20.

**Table 2-9 Emission Factors Assumptions**

Emissions g/million BTU	Natural gas	LPG	Gasoline	FT Distillate	Methanol	Ethanol
Fuel Evaporation and Leakage	10	10	5	5	5	5
NMOC Exhaust	0.2	0.2	0.2	0.2	0.2	0.2
Methane	0.4	0.4	0.4	0.4	0.4	0.4
Carbon Monoxide	8.0	8.0	8.0	8.0	8.0	8.0
Nitrous Oxide	0.25	0.375	0.375	0.375	0.125	0.25
NOx	20.0	30	30	30	10	20.0
SOx	0.1	1.0	0.1	0.1	0.1	0.1
PM	3.0	3.0	3.0	3.0	3.0	3.0

### 3. HYTHANE®

Hythane® is a registered trademark for a blend of hydrogen and natural gas. In Canada, the trademark is owned by the Quebec government and in the US, the owner is Hydrogen Components Inc. Other participants in the field refer to mixtures of the two gases as HCNG (hydrogen enriched compressed natural gas). Research into Hythane® has been going on for about 30 years and there have been several demonstrations of the technology over the years. Data from these demonstrations have been used in the modeling wherever possible.

#### 3.1 INTRODUCTION

Supplementation of hydrogen into natural gas (Hythane® or HCNG) extends the lean-burn, or charge-dilution limit of combustion in engines. Extremely low oxides of nitrogen (NO<sub>x</sub>) and carbon monoxide (CO) emissions can be achieved when a combined lean-burn and exhaust gas recirculation (EGR) combustion strategy is employed with Hythane®. The excess air from lean-burn can be used to reduce CO and non-methane hydrocarbons with an oxidation catalyst. The EGR is intended to be the primary charge dilution agent to reduce peak combustion temperatures thus leading to extremely low NO<sub>x</sub> emissions.

Without the hydrogen enhancement, natural gas would not be able to combust with the amount of charge dilution necessary to achieve the targeted NO<sub>x</sub> reductions without unacceptable sacrifices in fuel consumption, torque fluctuation, and hydrocarbon emissions. Hydrogen itself is not considered a low NO<sub>x</sub> fuel. Due to higher combustion temperatures than natural gas at equivalent air/fuel ratios, hydrogen actually produces higher NO<sub>x</sub> emissions. It is important that the hydrogen supplementation be significant enough to extend the charge-dilution limit to levels sufficient to reduce NO<sub>x</sub> emissions beyond what is capable with three-way catalyst technology at stoichiometric air/fuel ratios. Some developers have been able to achieve this with 20 vol % hydrogen and others recommend at least 30 vol % hydrogen to consistently achieve improvements in NO<sub>x</sub> emissions compared to natural gas alone with catalytic exhaust aftertreatment.

The engines are heavily modified to produce optimum results on Hythane®. There are tradeoffs involved between emissions and performance. The fuel impacts are therefore difficult to isolate as different companies may have different philosophies with respect to optimization. Given the relatively early stage of development of this fuel it was difficult to determine the best modeling parameters. In the following sections, the data used for both heavy duty and light duty applications is reviewed and the modeling assumptions are presented.

#### 3.2 LIGHT DUTY VEHICLES

There have not been any Hythane® powered vehicles offered for sale by Original Equipment Manufacturers. The Hythane® light duty vehicles that have been built have been modified by after market specialists. Given that a variety of engine operation strategies can be used, it is difficult to model a typical Hythane® vehicle. An engine that is operated at close to stoichiometric will have an efficiency and power output very close to the natural gas engine but will not get any of the NO<sub>x</sub> benefits available from a lean burn calibration. On the other hand a lean burn Hythane® engine will have very low NO<sub>x</sub>, a slight increase in thermal efficiency but a large drop in power and potentially a decrease in driveability. Some after market specialists have added a turbocharger or super charger to the Hythane® engine to recover some or all of the power lost from a lean burn calibration.

Cattelan and Wallace have published results for a production engine that was modified to operate on natural gas or Hythane® in a near stoichiometric condition. The Hythane® fuel contained 15% vol. hydrogen. The engine was tested on a dynamometer at three operating conditions approximating 0%, 15% and 30% of full load. The results of those tests are shown in the following table. The emissions are engine out results.

**Table 3-1 Hythane® Results in Light Duty Application**

	0% Load	15% Load	30% Load
Energy Consumption	Lower for Hythane	Same	same
NOx	Same	10-40% higher for Hythane	10-40% higher for Hythane
Total Hydrocarbons	10-20% lower for Hythane	Same	same
Carbon Monoxide	10-20% lower for Hythane	Same	same

If this engine was installed in a vehicle and the vehicle was tested over a driving cycle the energy consumption, hydrocarbon and carbon monoxide emissions would be the same as natural gas over the cycle. The nitrogen oxide emissions would be higher.

Hoekstra et. al. Published test results for a light duty engine operated on natural gas and natural gas with up to 50% vol. hydrogen. The engine was tested on a dynamometer at various loads and equivalence ratios from 0.75 to 0.50, which is a very lean condition. They concluded that the addition of hydrogen generally increased the NOx levels for the same equivalence ratio but the hydrogen also significantly extended the lean limit of combustion so that lower equivalence ratios were possible and low levels of NOx were achievable at the very low equivalence ratios. They also found that the thermal efficiency was near the maximum achieved at the very low equivalence ratios.

Hoekstra also reported results from a single cylinder engine operated on natural gas, hydrogen and various blends of the two fuels. These results show the trade-offs inherent in engine calibration. On natural gas the higher the engine efficiency the higher the NOx. The maximum efficiency varied from 41% to 41.5% depending on the spark advance. On 100% hydrogen the peak efficiency varied from 41.5 to 42.5% again depending on the spark advance. For the blend of 30% hydrogen, the peak engine efficiency varied from 40.5 to 41.2%. The operating conditions had a lower equivalence ratio than when operated on natural gas.

For the light duty vehicles, the model has been set so that the efficiency on Hythane® is the same as when the vehicle is operated on natural gas. The model has been programmed (on Sheet C) so that it is possible to set the relative efficiency on Hythane® different from that of natural gas so that if new data becomes available that indicates different efficiencies are possible with Hythane® the model can be readily adapted to accommodate the new data.

The exhaust emissions for Hythane® have also been set to be the same those of natural gas until better data becomes available. If data becomes available that indicates different emission rates from natural gas the changes to the program can be readily made on Sheet H.

### 3.3 HEAVY DUTY VEHICLES

Two buses were built for the Societe de transport de la communaute urbaine de Montreal to operate on Hythane® (20 vol % hydrogen). These buses were operated from September 1995 to

June 1996 and they accumulated a total of 18,270 km on two regular bus routes (Drolet). The engines for these buses were Cummins L10 G engines that had been modified to operate on Hythane®.

One of the buses was tested by Environment Canada (Environment Canada) and the test data from that has been used for the model. The bus was tested on both the Central Business District cycle and The New York City Composite cycles. The results were compared to the results from a natural gas bus with the same engine and exhaust treatment system that had previously been tested by Environment Canada. The test results are summarized in the following table. The fuel contained 20% hydrogen by volume. This is approximately 6% by energy content.

**Table 3-2 Emission Results Hythane® Buses**

Contaminant	CBD Results	NYC Composite Results	Average
Carbon Monoxide	Increase from zero	Increase from zero	Increase from zero
NOx	-44.6%	-16.4%	-30.5%
Methane	-5.4%	+80.6%	+37.6%
NMHC	-2.3%	2747%	1,372%
THC	-5.1%	94.3%	+44.6%
Particulate matter	119%	-37.2%	+40.9%
Aldehydes	-47.7%	32.4%	-7.6%
Carbon Dioxide	-6.4%	7.3%	-0.4%

The results are very different for the two driving cycles. Only the NOx emissions showed the same directional results for the two tests. The New York Composite cycle consumes more fuel and has higher NOx emissions are thus is a more aggressive driving cycle. The average carbon dioxide emissions suggest that the efficiency of the engine was lower on Hythane® as it was on natural gas.

The onroad fuel economy as measured throughout the primary portion of the Montreal demo consumed 22,030 M<sup>3</sup> of Hythane® with an average hydrogen content of 19.1% and the buses accumulated 22,413 km during this period. This provided a diesel equivalent fuel economy of 0.91 litres/km. A conventional diesel bus was reported to obtain 0.7 L/km over the same routes. This would suggest a relative efficiency of 77% of that of diesel fuel. The model has been set so that the efficiency of the engine on Hythane® is the same as it is on natural gas. There is very little data on which to base this value and at least some of the test data would indicate that this may be an optimistic assessment.

The heavy duty section of the model has been set up assuming that NOx emissions are reduced by 30% with the use of Hythane® and that all other emissions are the same as natural gas in a heavy duty engine application.

These buses are now in service at Sunline Transit in California. The engines have been updated with electronic controls but are otherwise the same as were used in Montreal. The buses were placed into service in April 2001 and except for the summer months have been in regular revenue service since. Sunline (Cromwell et al) report that the buses have similar fuel consumption to their CNG buses.

## 4. OTHER MODEL UPDATES

There were several small updates made to the model at the same time as the additional cycles were added. These updates, as described in the following sections, provide either additional flexibility to the user or more accurate calculations than earlier versions of GHGenius.

### 4.1 HYDROGEN TRANSPORTATION

Hydrogen can be transported by truck as compressed hydrogen, as liquid hydrogen, it can be pipelined as compressed hydrogen, or it could be generated on site so that there would be no distribution emissions. Previous versions of the model allowed for truck transportation or pipeline movement but not for generation on site. No changes have been made to the truck transportation calculations but the other options have been modified as described below.

#### 4.1.1 On Site Generation

The user now has the option of generating the hydrogen on site for all hydrogen pathways except the thermal cracking of water by nuclear energy. This option still requires either truck or pipeline movement. The user specifies on site generation on the input sheet in cell B44.

#### 4.1.2 Hydrogen Compression

The energy required for compression previously varied with the outlet pressure only. The equation was fit to some empirical data that was supplied to Delucchi. The problem with this approach was that the inlet pressure to the compressor also has a very significant impact on the energy required. The equation has been modified to accept both the inlet and outlet pressure and an adiabatic compression has been assumed. This is the approach used by Eliasson and Bossel (2002). The default inlet pressure is set to 100 psig as most reformers and electrolyzers produce hydrogen at some elevated pressure. This assumption gives values very close to the previous equation.

#### 4.1.3 Pipeline Transportation

Previous versions of the model allowed for pipeline distribution of hydrogen. The calculations were independent of pipeline distance, which does not seem reasonable. The calculations have been modified so that the user now specifies the hydrogen pipeline distance in miles on the input sheet.

The energy required for the pipeline has been estimated from Amos (1998). The actual energy requirements will be a function of pipeline diameter, surface roughness and flow rates. An average value has been calculated from data presented by Amos. The energy required is generally less than that previously calculated by the model and while it is still a simplified approach, it is more accurate than the method previously used.

### 4.2 LDV AND HDV SUMMARIES

All of the hydrogen pathways have been added to both the LDV and HDV summary sheets so that the lifecycle emissions for all contaminants are available for each stage of the fuel cycles.

Fuel pathways for fuels other than hydrogen have also been added to the summary sheets if they were previously on sheet AC.

### 4.3 COST EFFECTIVENESS

The LDV and HDV Cost Effectiveness sheets have been updated to include all of the fuel cycles that are on sheet AC. In the case of hydrogen, the user can specify different hydrogen costs for each of the different pathways. Different costs can be inputted for light duty applications and for heavy duty applications if desired.

The year that the results can be discounted to is now set by the user on the cost input sheet rather than just having the results discounted to the year 2000.

## 5. GREENHOUSE GAS RESULTS

The greenhouse gas emission results are presented for the new hydrogen production cycles and the use of hydrogen combined with natural gas in light and heavy-duty engines. The results are presented as carbon dioxide equivalents for the emissions of carbon dioxide, methane and nitrous oxide. The intent of this work has been to add new hydrogen pathways to the model and not to analyze each pathway. The default inputs for the model are based on commercial units wherever possible. In some cases, there are more efficient commercial systems available at a higher capital cost that could be analyzed. The model is now capable of doing this but performing those analyses is beyond the scope of this work.

### 5.1 HYDROGEN PRODUCTION

The greenhouse gas emission results for each of the new production cycles is presented for the year 2005 and for the default values that been created in the model for each of the cycles. The model has been run for Central Canada. The results are presented on a well to tank basis and on a well to wheel basis assuming the hydrogen is used in fuel cell vehicles. In the case of those fuels for which the model already contained on board emission results, a comparison between the onboard and off board results are presented.

#### 5.1.1 Methanol to Hydrogen

The well to tank results for methanol to hydrogen are presented in the following table. The results are compared to those for steam methane reforming. In both cases, it is assumed that the hydrogen is produced and used on site. In the case of the methanol to hydrogen pathway, feedstock recovery includes the emissions from the natural gas and methanol production stages. The emissions from the gas leaks and CO<sub>2</sub> removal steps are higher than the SMR because of the lower overall energy efficiency.

**Table 5-1 Well to Tank Emissions, Methanol to Hydrogen**

	Hydrogen from SMR	Methanol to Hydrogen
	Gm/million BTU	Gm/million BTU
Fuel Dispensing	3,650	3,650
Fuel Distribution	0	0
Fuel Production	76,160	77,671
Feedstock Transmission	3,289	7,078
Feedstock Recovery	5,621	17,646
Gas Leaks and Flares	5,280	3,783
CO <sub>2</sub> removed from NG	963	1,129
<b>Total</b>	<b>94,954</b>	<b>110,957</b>

In the following table the well to wheels results are shown. In this case, the comparison is made to both the hydrogen produced by SMR and a methanol powered fuel cell vehicle. In this case reforming methanol at the service station produces results very similar to using the methanol onboard the vehicle to produce reformat for the fuel cell.



**Table 5-2 Well to Wheel Emissions, Methanol to Hydrogen**

	Hydrogen from SMR	Methanol to Hydrogen Off Board	Methanol Fuel Cell Vehicle
	Gm/mile	Gm/mile	Gm/mile
Vehicle Operation	0	0	193.7
Fuel Dispensing	8.8	8.8	0.7
Fuel Distribution	0	0	17.6
Fuel Production	182.7	186.3	27.5
Feedstock Transmission	7.9	17.0	1.2
Feedstock Recovery	13.5	42.3	16.4
Gas Leaks and Flares	15.0	11.8	12.2
Total	227.8	266.2	269.3
% change from gasoline ICE	-51.1	-42.8	-42.2

**5.1.2 Gasoline Reforming**

The well to tank results for gasoline to hydrogen are presented in the following table. The results are again compared to those for steam methane reforming. In both cases, it is assumed that the hydrogen is produced and used on site. Like the methanol case, feedstock recovery includes the oil and gasoline production.

**Table 5-3 Well to Tank Emissions, Gasoline to Hydrogen**

	Hydrogen from SMR	Gasoline to Hydrogen
	Gm/million BTU	Gm/million BTU
Fuel Dispensing	3,650	3,650
Fuel Distribution	0	0
Fuel Production	76,160	137,310
Feedstock Transmission	3,289	2,383
Feedstock Recovery	5,621	42,459
Gas Leaks and Flares	5,280	5,043
CO <sub>2</sub> removed from NG	963	0
Total	94,954	190,846

In the following table, the well to wheels results are shown. In this case, the comparison is made to both the hydrogen produced by SMR and a gasoline powered fuel cell vehicle. There is a significant difference in the results for the off board and on board gasoline pathways. The off board results are what one would expect from the existing steam reforming technology and the on board results are what are projected to be achievable based on early laboratory results of autothermal reforming technologies. If autothermal reforming of hydrocarbons can be perfected then it may be possible to reduce the emissions from an off board system.

**Table 5-4 Well to Wheel Emissions, Gasoline to Hydrogen**

	Hydrogen from SMR	Gasoline to Hydrogen Off Board	Gasoline Fuel Cell Vehicle
	Gm/mile	Gm/mile	Gm/mile
Vehicle Operation	0	0	257.6
Fuel Dispensing	8.8	8.8	0.4
Fuel Distribution	0	0	4.6
Fuel Production	182.7	329.4	47.1
Feedstock Transmission	7.9	5.7	0.7
Feedstock Recovery	13.5	101.9	35.2
Gas Leaks and Flares	15.0	12.1	9.8
Total	227.8	457.8	355.4
% change from gasoline ICE	-51.1	-1.7	-23.7

### 5.1.3 Ethanol to Hydrogen

The well to tank results for corn and lignocellulosic ethanol to hydrogen systems are presented in the following table. The lignocellulosic ethanol is made from agricultural feedstocks in this case (100% grass in the model). The results are compared to those for steam methane reforming. In both cases, it is assumed that the hydrogen is produced and used on site. The carbon in air credit has been applied to the fuel production stage since that is where the carbon emissions occur.

**Table 5-5 Well to Tank Emissions, Ethanol to Hydrogen**

	Hydrogen from SMR	Ethanol to Hydrogen	Ethanol to Hydrogen
	Gm/million BTU	Gm/million BTU	Gm/million BTU
Feedstock		Corn Ethanol	Lignocellulosic
Fuel Dispensing	3,650	3,650	3,650
Fuel Distribution	0	0	0
Fuel Production	76,160	5,077	5,077
Feedstock Transmission	3,289	2,691	2,691
Feedstock Recovery	5,621	82,341	16,541
Land use change	0	18,036	1,679
Fertilizer manufacture	0	11,266	1,320
Gas Leaks and Flares	5,280	0	0
CO <sub>2</sub> removed from NG	963	0	0
Co-products	0	-44,836	-7,078
Total	94,954	78,226	23,880

In the following table the well to wheels results are shown. In this case, the comparison is made to both the hydrogen produced by SMR and an ethanol powered fuel cell vehicle. In this case, reforming ethanol at the service station produces results very similar to using the ethanol onboard the vehicle to produce reformat for the fuel cell.

**Table 5-6 Well to Wheel Emissions, Ethanol to Hydrogen**

	Hydrogen from SMR	Ethanol to Hydrogen Off Board	Ethanol to Hydrogen Off Board	Ethanol Fuel Cell Vehicle	Ethanol Fuel Cell Vehicle
	Gm/mile	Gm/mile	Gm/mile	Gm/mile	Gm/mile
Feedstock		Corn	Grass	Corn	Grass
Vehicle Operation	0	0	0	247.5	247.5
Fuel Dispensing	8.8	8.8	8.8	0.6	0.6
Fuel Distribution	0	0	0	5.7	5.7
Fuel Production	182.7	12.2	12.2	142.4	25.9
Feedstock Transmission	7.9	6.5	6.5	5.9	3.5
Feedstock, fertilizer and land use	13.5	267.8	46.9	94.1	15.6
Gas Leaks and Flares	15.0	0	0	0	0
Co-products	0	-107.6	-17.0	-95.0	-15.0
Carbon in air				-247.6	-247.6
Total	227.8	187.7	57.3	153.6	36.0
% change from gasoline ICE	-51.1	-59.7	-87.7	-67.0	-92.3

**5.1.4 FT Distillate Reforming**

The well to tank results for FT Distillate to hydrogen are presented in the following table. The results are compared to those for steam methane reforming. In both cases, it is assumed that the hydrogen is produced and used on site.

**Table 5-7 Well to Tank Emissions, FT Distillate to Hydrogen**

	Hydrogen from SMR	FT Distillate to Hydrogen
	Gm/million BTU	Gm/million BTU
Fuel Dispensing	3,650	3,650
Fuel Distribution	0	0
Fuel Production	76,160	130,926
Feedstock Transmission	3,289	5,028
Feedstock Recovery	5,621	56,379
Gas Leaks and Flares	5,280	7,221
CO <sub>2</sub> removed from NG	963	2,155
Total	94,954	205,359

In the following table, the well to wheels results are shown. In this case, the comparison is made to both the hydrogen produced by SMR and a FT Distillate powered fuel cell vehicle. Similar to the gasoline case, the assumptions made about the efficiency of the on board reformers are much higher than that which has been demonstrated by the commercial steam reformers.

**Table 5-8 Well to Wheel Emissions, FT Distillate to Hydrogen**

	Hydrogen from SMR	FT Distillate to Hydrogen Off Board	FT Distillate Fuel Cell Vehicle
	Gm/mile	Gm/mile	Gm/mile
Vehicle Operation	0	0	252.0
Fuel Dispensing	8.8	8.8	0.4
Fuel Distribution	0	0	10.0
Fuel Production	182.7	314.1	87.1
Feedstock Transmission	7.9	12.1	1.8
Feedstock Recovery	13.5	135.5	25.0
Gas Leaks and Flares	15.0	22.5	18.6
Total	227.8	492.6	394.9
% change from gasoline ICE	-51.1	+5.8	-15.2

### 5.1.5 LPG Reforming

The well to tank results for LPG reforming to hydrogen are presented in the following table. The results are compared to those for steam methane reforming. In both cases, it is assumed that the hydrogen is produced and used on site.

**Table 5-9 Well to Tank Emissions, LPG to Hydrogen**

	Hydrogen from SMR	LPG to Hydrogen
	Gm/million BTU	Gm/million BTU
Fuel Dispensing	3,650	3,650
Fuel Distribution	0	0
Fuel Production	76,160	122,351
Feedstock Transmission	3,289	2,474
Feedstock Recovery	5,621	8,425
Gas Leaks and Flares	5,280	4,085
CO <sub>2</sub> removed from NG	963	1,265
Total	94,954	142,249

In the following table, the well to wheels results are shown. In this case, the comparison is made to the hydrogen produced by SMR. The option of on board LPG reforming has not been included in the model as this is not a pathway that any auto manufacturer is pursuing at this time.

**Table 5-10 Well to Wheel Emissions, LPG to Hydrogen**

	Hydrogen from SMR	LPG to Hydrogen Off Board
	Gm/mile	Gm/mile
Vehicle Operation	0	0
Fuel Dispensing	8.8	8.8
Fuel Distribution	0	0
Fuel Production	182.7	293.5
Feedstock Transmission	7.9	5.9
Feedstock Recovery	13.5	20.2
Gas Leaks and Flares	15.0	12.8
Total	227.8	341.3
% change from gasoline ICE	-51.1	-26.7

**5.1.6 Thermal Cracking of Water**

The use of nuclear power to produce electricity to produce hydrogen via electrolysis is already a commercial pathway. This pathway can be modeled in GHGenius by setting cell J:B56 equal to cell J:F27, this change sets all the electricity used for electrolysis and compression to be nuclear energy. This produces an extremely low GHG hydrogen pathway. For the case where the electrolysis is performed onsite the emissions are compared to those from SMR in the following table.

**Table 5-11 Well to Tank Emissions, Electrolysis from Conventional Nuclear Power**

	Hydrogen from SMR	Electrolysis
	Gm/million BTU	Gm/million BTU
Fuel Dispensing	3,650	255
Fuel Distribution	0	0
Fuel Production	76,160	4,909
Feedstock Transmission	3,289	0
Feedstock Recovery	5,621	0
Gas Leaks and Flares	5,280	0
CO <sub>2</sub> removed from NG	963	0
Total	94,954	5,164

In the following table the well to wheels results are shown and compared to those from SMR.

**Table 5-12 Well to Wheel Emissions, Electrolysis from Conventional Nuclear Power**

	Hydrogen from SMR	Hydrogen from Electrolysis
	Gm/mile	Gm/mile
Vehicle Operation	0	0
Fuel Dispensing	8.8	0.6
Fuel Distribution	0	0
Fuel Production	182.7	11.8
Feedstock Transmission	7.9	0
Feedstock Recovery	13.5	0
Gas Leaks and Flares	15.0	0
Total	227.8	12.4
% change from gasoline ICE	-51.1	-97.3

One of the advantages of this pathway is that the hydrogen production can take place remotely from the electricity production site provided the electrical distribution grid has surplus capacity. One of the disadvantages is that the overall efficiency is relatively low, the power generation is about 35% at the nuclear power plant (thermal energy to electricity), the distribution system is about 92% efficient and electrolysis is about 70% efficient for an overall efficiency of about 22.5%.

The thermal cracking of water route using heat from a nuclear power plant offers higher overall efficiency at the production step but will require a hydrogen distribution system. This system would entail either liquefaction and truck distribution of the liquid hydrogen or perhaps a compressed gas pipeline system. Both of these systems will create some GHG's. The well to tank emissions for both of these options is shown in the following table. In both cases, the distribution distance is 300 miles. The electrical energy for liquefaction and compression is assumed to be nuclear, although it may be that the thermal cracking of water is not done in a co-generation scheme. The higher efficiency Sulphur Iodine cycle has been modeled.

**Table 5-13 Well to Tank Emissions, Nuclear Power and Thermal Cracking**

	Compressed Hydrogen	Liquid Hydrogen
	Gm/million BTU	Gm/million BTU
Fuel Dispensing	255	1,085
Fuel Distribution	301	309
Fuel Production	42	42
Feedstock Transmission	18	18
Feedstock Recovery	431	431
Gas Leaks and Flares	0	0
CO <sub>2</sub> removed from NG	0	0
Total	1,047	1,885

In the following table the well to wheels results are shown and compared to those from SMR.

**Table 5-14 Well to Wheel Emissions, Nuclear Power and Thermal Cracking**

	Liquid Hydrogen	Compressed Hydrogen
	Gm/mile	Gm/mile
Vehicle Operation	0	0
Fuel Dispensing	2.6	0.6
Fuel Distribution	0.7	0.7
Fuel Production	0.1	0.1
Feedstock Transmission	0	0
Feedstock Recovery	1.0	1.0
Gas Leaks and Flares	0	0
Total	4.5	2.5
% change from gasoline ICE	-99.0	-99.5

This option provides lower GHG emissions than conventional nuclear energy and electrolysis but the improvement is relatively small especially when the investment in the technology required to move these processes from the lab to a commercial reality is considered. The energy efficiency of this pathway is higher than the more conventional pathway which would have other advantages such as fewer plants being required to supply a given quantity of hydrogen and less waste to deal with from the nuclear plants.

## 5.2 HYTHANE® USE

The greenhouse gas emissions from the use of Hythane® in light and heavy duty vehicles is shown in the following sections. It has been assumed that the fuel contains 20% hydrogen by volume. This is about a 6% hydrogen content by energy content. The hydrogen can be produced by either SMR or electrolysis or a blend of the two in the model. The results are presented for 100% SMR. In the following table the well to tank emissions for Hythane® are compared to those for compressed natural gas. These results are not directly comparable since there will be no carbon dioxide formed when the hydrogen is burned in the engine.

**Table 5-15 Well to Tank Emissions, Hythane® and CNG**

	Compressed Natural Gas	Hythane®
	Gm/million BTU	Gm/million BTU
Fuel Dispensing	1,241	1,426
Fuel Distribution	2,309	2,131
Fuel Production	3,043	8,656
Feedstock Transmission	0	252
Feedstock Recovery	899	1,261
Gas Leaks and Flares	3,840	3,951
CO <sub>2</sub> removed from NG	676	698
Total	12,009	18,376

### 5.2.1 Light Duty Vehicles

The well to wheel emissions for Hythane® are compared to those for compressed natural gas in the following table. It can be seen from the table that the GHG emissions are not as good as there are just for natural gas. This is due to the lower efficiency for the hydrogen pathway where

there is an efficiency loss in converting the natural gas to hydrogen that is not recovered in the engine.

**Table 5-16 LDV Well to Wheel Emissions, Hythane® and CNG**

	Compressed Natural Gas	Hythane®
	Gm/mile	Gm/mile
Vehicle Operation	275.6	256.0
Fuel Dispensing	6.2	7.2
Fuel Distribution	11.6	10.7
Fuel Production	15.3	43.5
Feedstock Transmission	0	1.3
Feedstock Recovery	4.5	6.3
Gas Leaks and Flares	22.7	23.3
Total	335.8	348.3
% change from gasoline ICE	-27.9	-25.2

### 5.2.2 Heavy Duty Vehicles

The well to wheels results for heavy-duty applications are shown in the following table. The percent change from the diesel engine is not as high as it was for the light duty applications as the relative efficiency for the gaseous fuels are lower for the diesel than the spark ignited engines.

**Table 5-17 HDV Well to Wheel Emissions, Hythane® and CNG**

	Compressed Natural Gas	Hythane®
	Gm/mile	Gm/mile
Vehicle Operation	1,445.0	1341.4
Fuel Dispensing	33.8	63.2
Fuel Distribution	62.9	58.3
Fuel Production	82.9	238.6
Feedstock Transmission	24.5	7.0
Feedstock Recovery	123.0	34.4
Gas Leaks and Flares	0	126.3
Total	1772.0	1869.2
% change from Diesel ICE	-20.3	-15.9

### 5.3 SUMMARY GHG EMISSIONS WELL TO TANK

The following table summarizes the GHG emissions for the new hydrogen production cycles on a well to tank basis. The results are compared to the steam reforming of natural gas.



**Table 5-18 GHG Emissions Summary**

	Hydrogen from SMR	Methanol to Hydrogen	Gasoline to Hydrogen	FT Distillate to Hydrogen	Corn Ethanol to Hydrogen	Cellulose Ethanol to Hydrogen	LPG to Hydrogen
	Gm/million BTU	Gm/million BTU	Gm/million BTU	Gm/million BTU	Gm/million BTU	Gm/million BTU	Gm/million BTU
Fuel Dispensing	3,650	3,650	3,650	3,650	3,650	3,650	3,650
Fuel Distribution	0	0	0	0	0	0	0
Fuel Production	76,160	77,671	137,310	130,926	5,077	5,077	122,351
Feedstock Transmission	3,289	7,078	2,383	5,028	2,691	2,691	2,474
Feedstock Recovery	5,621	17,646	42,459	56,379	82,341	16,541	8,425
Land use change	0	0	0	0	18,036	1,679	0
Fertilizer manufacture	0	0	0	0	11,266	1,320	0
Gas Leaks and Flares	5,280	3,783	5,043	7,221	0	0	4,085
CO <sub>2</sub> removed from NG	963	1,129	0	2,155	0	0	1,265
Co-products	0	0	0	0	-44,836	-7,078	0
<b>Total</b>	<b>94,954</b>	<b>110,957</b>	<b>190,846</b>	<b>205,359</b>	<b>78,226</b>	<b>23,880</b>	<b>142,249</b>

## 6. OTHER RESULTS

Each of the new pathways has been added to all of the relevant sections of the model. In addition to the greenhouse gas emissions the model calculates energy balances, cost effectiveness of greenhouse gas reductions and summarizes all of the emissions for each stage of the pathway. These other results are briefly presented in the following sections.

### 6.1 ENERGY EFFICIENCY

The energy consumed per net BTU of hydrogen delivered is shown in the following table for the new hydrogen pathways. This data is for the year 2005 and for onsite hydrogen production. The fuel production line is a measure of the reformer efficiency. The methanol reformer is the most efficient and the gasoline the least efficient. The feedstock recovery line is a measure of the efficiency of the production of the feed for the reformer. In this case, natural gas and LPG are the most efficient.

**Table 6-1 Energy Consumed for Hydrogen Pathways**

Feedstock	Natural Gas	Methanol	Gasoline	FT Distillate	LPG	Corn Ethanol	Grass Ethanol
Fuel dispensing	0.0647	0.0647	0.0647	0.0647	0.0647	0.0647	0.0647
Fuel distribution, storage	0.0000	0.0000	0.0000	0.0000	0.0000	0.0000	0.0000
Fuel production	0.4429	0.2373	0.9733	0.9237	0.9688	0.8161	0.8161
Feedstock transmission	0.0440	0.0609	0.0888	0.0889	0.0887	0.0853	0.0853
Feedstock recovery	0.0693	0.5382	0.5177	1.5227	0.1262	1.1972	1.7109
Ag. chemical manufacture	n.a.	n.a.	n.a.	n.a.	n.a.	0.1670	0.0137
<b>Total</b>	<b>0.62</b>	<b>0.90</b>	<b>1.64</b>	<b>2.60</b>	<b>1.25</b>	<b>2.33</b>	<b>2.69</b>

The energy efficiency data can also be shown on a BTU/mile driven basis. For hydrogen fuel cells, the results for the same case as the previous table are shown below.

**Table 6-2 Energy Consumed for Hydrogen Pathways**

Feedstock	Natural Gas	Methanol	Gasoline	FT Distillate	LPG	Corn Ethanol	Grass Ethanol
	BTU/mile	BTU/mile	BTU/mile	BTU/mile	BTU/mile	BTU/mile	BTU/mile
End Use	2,399	2,399	2,399	2,399	2,399	2,399	2,399
Fuel dispensing	155	155	155	155	155	155	155
Fuel distribution, storage	0	0	0	0	0	0	0
Fuel production	1,063	569	2,335	2,216	2,324	1,958	1,958
Feedstock transmission	106	146	213	213	213	205	205
Feedstock recovery	166	1,291	1,242	3,653	303	2,872	4,104
Ag. chemical manufacture	0	0	0	0	0	401	33
<b>Total</b>	<b>3,889</b>	<b>4,561</b>	<b>6,344</b>	<b>8,636</b>	<b>5,394</b>	<b>7,989</b>	<b>8,854</b>

The following table compares the energy consumed per mile or a light duty CNG vehicle with a light duty Hythane® vehicle. Similar data is available in the model for heavy-duty applications.

**Table 6-3 Energy Consumed for CNG and Hythane® Pathways**

Feedstock	Compressed Natural Gas	Hythane®
	BTU/mile	BTU/mile
End Use	5,016	5,011
Fuel dispensing	110	127
Fuel distribution, storage	155	143
Fuel production	234	384
Feedstock transmission	0	17
Feedstock recovery	62	83
Ag. chemical manufacture	0	0
<b>Total</b>	<b>5,577</b>	<b>5,764</b>

## 6.2 COST EFFECTIVENESS

The model calculates the cost effectiveness of greenhouse gas emissions from the emission data, the vehicle and fuel costs and the expected life of the vehicles. All of the new hydrogen cycles have been added and there is the provision for inputting different hydrogen costs for the different pathways. The defaults in the model have the same hydrogen costs for each pathway. The cost effectiveness for the light-duty fuel cell applications in the year 2005 is shown in the following table. The costs discounted to the year 2002 are also included. Similar information is in the model for heavy-duty applications.

**Table 6-4 Light-Duty Fuel Cells GHG Cost Effectiveness**

Hydrogen Pathway	Cost Effectiveness \$/tonne	Cost Effectiveness \$/tonne, discounted to 2002
Natural Gas SMR	400.09	345.61
Methanol to Hydrogen	473.55	409.07
Ethanol to Hydrogen (corn)	344.26	297.39
Ethanol to Hydrogen (grass)	236.88	204.63
Gasoline to Hydrogen	5,678.03	4,904.89
FT Distillate to hydrogen	GHG Increases	GHG Increases
LPG to Hydrogen	738.80	638.20
Methanol FCV	262.45	226.71
Gasoline FCV	392.78	339.30
FT Distillate FCV	1,323.87	1,143.61
Ethanol FCV (corn)	249.61	215.62
Ethanol FCV (grass)	175.31	151.44

### 6.3 EMISSIONS SUMMARIES

The emissions summaries for light-duty and heavy-duty applications has been updated to include all of the new hydrogen pathways and all of the fuel cycles that were previously on the primary output sheet AC. The typical output for the primary greenhouse gases for the new cycles is shown in the following table. The summary sheets also include the criteria air contaminants, carbon monoxide, VOC's, nitrogen oxides, sulphur oxides, particulate matter and CFC's and HFC's as shown in Table 6-6. Similar tables can be constructed for the heavy-duty applications.

**Table 6-5 GHG Emissions Summary, Light Duty Fuel Cell Vehicles**

	ICE	CH2 Fuel Cell	CH2 Fuel Cell	CH2 Fuel Cell	CH2 Fuel Cell	CH2 Fuel Cell	CH2 Fuel Cell	CH2 Fuel Cell	CH2 Fuel Cell	Methanol Fuel Cell
	LS Gas	NG	Methanol	Gasoline	Ethanol (W0/G100)	Ethanol Corn	F-T Diesel	LPG	Nuclear	M100NG
<b>CO2</b>	g/mile	g/mile	g/mile	g/mile	g/mile	g/mile	g/mile	g/mile	g/mile	g/mile
Vehicle Operation	338.519	0.000	0.000	0.000	0.000	0.000	0.000	0.000	0.000	193.682
Upstream	113.861	210.263	252.369	435.314	30.755	183.625	465.164	325.570	2.158	62.290
Vehicle Material & Assembly	47.804	50.901	50.901	50.901	50.901	50.901	50.901	50.901	50.901	50.483
Total	500.184	261.164	303.271	486.215	81.657	234.527	516.065	376.471	53.059	306.455
% total CO2-Equiv.	94.579	92.818	94.843	95.073	73.653	97.217	94.478	95.350	94.604	95.040
<b>CH4</b>										
Vehicle Operation	0.039	0.000	0.000	0.000	0.000	0.000	0.000	0.000	0.000	0.000
Upstream	0.990	0.802	0.601	0.946	0.881	0.816	1.191	0.691	0.008	0.590
Vehicle Material & Assembly	0.100	0.109	0.109	0.109	0.109	0.109	0.109	0.109	0.109	0.108
Total	1.129	0.911	0.709	1.054	0.989	0.924	1.300	0.800	0.117	0.698
% total CO2-Equiv.	4.483	6.800	4.658	4.330	18.738	8.047	4.997	4.254	4.380	4.545
<b>N2O</b>										
Vehicle Operation	0.008	0.000	0.000	0.000	0.000	0.000	0.000	0.000	0.000	0.000
Upstream	0.006	0.002	0.004	0.009	0.026	-0.042	0.008	0.004	0.001	0.003
Vehicle Material & Assembly	0.001	0.001	0.001	0.001	0.001	0.001	0.001	0.001	0.001	0.001
Total	0.016	0.003	0.005	0.010	0.027	-0.041	0.009	0.005	0.002	0.004
% total CO2-Equiv.	0.938	0.382	0.499	0.597	7.609	-5.264	0.526	0.395	1.016	0.415
<b>Total CO2 Equiv.</b>	<b>528.852</b>	<b>281.372</b>	<b>319.760</b>	<b>511.413</b>	<b>110.867</b>	<b>241.240</b>	<b>546.231</b>	<b>394.830</b>	<b>56.086</b>	<b>322.450</b>

**Table 6-6 Other Emissions Summary, Light Duty Fuel Cell Vehicles**

	ICE	CH2 Fuel Cell	CH2 Fuel Cell	CH2 Fuel Cell	CH2 Fuel Cell	CH2 Fuel Cell	CH2 Fuel Cell	CH2 Fuel Cell	CH2 Fuel Cell	Methanol Fuel Cell
	LS Gas	NG	Methanol	Gasoline	Ethanol (W0/G100)	Ethanol Corn	F-T Diesel	LPG	Nuclear	M100NG
<b>CFCs+HFCs</b>	g/mile	g/mile	g/mile	g/mile	g/mile	g/mile	g/mile	g/mile	g/mile	g/mile
Vehicle Operation	0.005	0.005	0.005	0.005	0.005	0.005	0.005	0.005	0.005	0.005
Upstream	0.000	0.000	0.000	0.000	0.000	0.000	0.000	0.000	0.000	0.000
Vehicle Mat & Asmby	0.000	0.000	0.000	0.000	0.000	0.000	0.000	0.000	0.000	0.000
Total	0.005	0.005	0.005	0.005	0.005	0.005	0.005	0.005	0.005	0.005
<b>CO</b>										
Vehicle Operation	15.504	0.000	0.000	0.000	0.000	0.000	0.000	0.000	0.000	0.004
Upstream	0.655	0.156	0.129	0.592	0.486	0.132	0.272	0.155	0.028	0.148
Vehicle Mat & Asmby	0.114	0.088	0.088	0.088	0.088	0.088	0.088	0.088	0.088	0.090
Total	16.273	0.244	0.218	0.681	0.574	0.221	0.360	0.243	0.116	0.241
<b>NOx</b>										
Vehicle Operation	0.511	0.000	0.000	0.000	0.000	0.000	0.000	0.000	0.000	0.014
Upstream	0.774	0.304	0.501	0.855	0.539	1.728	0.688	0.390	0.021	0.482
Vehicle Mat & Asmby	0.137	0.147	0.147	0.147	0.147	0.147	0.147	0.147	0.147	0.147
Total	1.422	0.451	0.648	1.001	0.686	1.875	0.835	0.537	0.167	0.643
<b>VOC-Ozone weighted</b>										
Vehicle Operation	0.416	0.000	0.000	0.000	0.000	0.000	0.000	0.000	0.000	0.010
Upstream	0.304	0.013	0.052	0.218	0.097	0.864	0.043	0.033	0.002	0.063
Vehicle Mat & Asmby	0.033	0.037	0.037	0.037	0.037	0.037	0.037	0.037	0.037	0.036
Total	0.753	0.050	0.089	0.255	0.134	0.900	0.080	0.070	0.039	0.109
<b>SOx</b>										
Vehicle Operation	0.033	0.028	0.028	0.028	0.028	0.028	0.028	0.028	0.019	0.002
Upstream	0.210	0.057	0.081	0.260	0.126	0.113	0.134	0.107	0.057	0.045
Vehicle Mat & Asmby	0.168	0.203	0.203	0.203	0.203	0.203	0.203	0.203	0.203	0.207
Total	0.411	0.287	0.312	0.491	0.357	0.344	0.365	0.337	0.279	0.253
<b>PM</b>										
Vehicle Operation	0.055	0.000	0.000	0.000	0.000	0.000	0.000	0.000	0.000	0.000
Upstream	0.041	0.020	0.021	0.055	0.122	0.058	0.033	0.027	0.001	0.011
Vehicle Mat & Asmby	0.174	0.172	0.172	0.172	0.172	0.172	0.172	0.172	0.172	0.179
Total	0.271	0.193	0.194	0.227	0.295	0.230	0.205	0.199	0.173	0.190

## 7. CONCLUSIONS

The GHGenius model has been successfully updated with additional hydrogen production and hydrogen utilization pathways. The following hydrogen production pathways have been added:

- Off board reforming of methanol
- Off board reforming of ethanol
- Off board reforming of gasoline
- Off board reforming of FT Distillate
- Off board reforming of LPG
- The use of nuclear energy to produce hydrogen through thermal cracking

In addition, the use of mixtures of natural gas and hydrogen (Hythane®) in both light duty spark ignited engines and in heavy duty natural gas engines have been added to the model. The hydrogen for these mixtures can be produced either from SMR or from electrolysis.

The default values that have been programmed into the model have been based on commercial data where ever possible. With these values the only hydrogen production pathways that would appear to have potential from a GHG perspective are the off board methanol to hydrogen cycle and the nuclear route. The nuclear pathways are estimated by their developers to be 30 years from commercialization. There is considerable effort being undertaken developing improved technologies, such as autothermal reforming, for producing hydrogen using the feedstocks that have been added to the model. The model will accurately predict the emissions from these new technologies once the operating parameters are known. This will allow the CTFCA to analyze the greenhouse gas benefits of demonstration projects before the projects are funded by the CTFCA.

There is full functionality in the model for the additional hydrogen pathways. All of the results such as the energy balances of the pathways, the energy efficiency on a per mile driven basis, the cost effectiveness of the GHG emission reductions and the summary of the all emissions by stage of production are available in the model.

## 8. REFERENCES

(S&T)<sup>2</sup> Consultants Inc. 2000. Assessment of Emissions of Greenhouse Gases from Fuel Cell Vehicles. Prepared for Methanex Corporation. June 2000.

Amos, W. 1998. Costs of Storing and Transporting Hydrogen. National Renewable Energy Laboratory. NREL/TP-570-25106. November 1998.

Andseta, S., Thompson, M., Jarrell, J., Pendergast, D. 1998. CANDU Reactors and Greenhouse Gas Emissions. 11<sup>th</sup> Pacific Basin Nuclear Conference, Banff, Alberta. May 1998. [www.can.ca/ccb2.html](http://www.can.ca/ccb2.html)

Besenbruch, G., Brown, L., Funk, J., Showalter, S. 2000. High Efficiency Generation of Hydrogen Fuels Using Nuclear Power. Presented at OECD/NEA Information Exchange Meeting on the Nuclear Production of Hydrogen, October 2-3, 2000, Paris, France. GA-A23510.

Cattelan, A., Wallace, J. 1995. Exhaust Emission and Energy Consumption Effects from Hydrogen Supplementation of Natural Gas. SAE 952497.

Cheminfo Services Inc. 2000. Ethanol Production in Alberta. Prepared for Interdepartmental Ethanol Committee, Government of Alberta. April 2000.

Contadini, F. 1999. Upstream Emissions and Energy Efficiency for Hydrogen Fuel. Fuel Cell Vehicle Technology Conference. University of California at Davis. March 1999.

Contadini, F., Moore, R., Sperling, D., Sundaresan, M. 2000. Life-Cycle Emissions of Alternative Fuels for Transportation: Dealing with Uncertainties. SAE 2000-01-0597. March 2000.

Cromwell, R., Williams, J., Lynch, F. 2002. Sunline Transit Agency Tests Hythane® in Closed Loop CNG Engine. Presented at the 14<sup>th</sup> World Hydrogen Energy Conference, Montreal Quebec. June 2002.

Drolet, B., Gretz, J. 2002. The Euro-Quebec Hydro-Quebec Pilot Project. The Beginning of the Industrialization of Hydrogen. Part 2: The View from North America. Presented at the 14<sup>th</sup> World Hydrogen Energy Conference, Montreal Quebec. June 2002.

EIA. Energy Information Administration. Thermal Energy Conversions of Nuclear Fuels. [http://eia.doe.gov/cneaf/nuclear/page/uran\\_enrich\\_fuel/convert.html](http://eia.doe.gov/cneaf/nuclear/page/uran_enrich_fuel/convert.html)

Eliasson, B., Bossel, U. 2002. The Future of the Hydrogen Economy: Bright or Bleak? Fuel Cell World, July 5, 2002. Lucerne, Switzerland.

Environment Canada. 1996. Study of Heavy Duty Vehicle Exhaust Emissions from a Modified CNG us Fueled with Hythane®. MSED Report #96-26766. Prepared by Peter Barton.

Hoekstra, R., Van Blarigan, P., Mulligan, N. 1996. NOx Emissions and efficiency of Hydrogen, Natural Gas, and Hydrogen/Natural Gas Blended Fuels. SAE 961109.

Levelton Engineering Ltd. 1999. Alternative and Future Fuels and Energy Sources for Road Vehicles. Prepared for Transportation Issue Table. National Climate Change Process. July 1999.

Levelton Engineering Ltd. 1999b. Assessment of Net Emissions of Greenhouse Gases from Ethanol-Gasoline Blends in Southern Ontario. Prepared for Agriculture and Agri-Food Canada, Vancouver, BC, August 1999.



Levelton Engineering Ltd., 1999c Assessment of Net Emissions of Greenhouse Gases from Ethanol-Gasoline Blends in Canada: Lignocellulosic Feedstocks. Prepared for Agriculture and Agri-Food Canada, Vancouver, BC, December 1999.

Linde. 1992. Processes for Industrial Production of Hydrogen and Associated Environmental Effects. Reports on Science and Technology. No. 50. 1992. ISSN 0942-5268.

Mahler. 1996. Corporate Brochure "Hydrogen Generators".

NPRA. Recent Comments Filed by NPRA. [www.npradc.org/environmental/other/4-27-00.html](http://www.npradc.org/environmental/other/4-27-00.html)

RFA. 2002. Renewable Fuels Association. Ethanol Report. Issue 162. June 11, 2002.

Spath, P., Mann, M. 2001. Life Cycle Assessment of Hydrogen Production via Natural Gas Steam Reforming. NREL/TP-570-27637. Revised February 2001.

US DOE. 1999. Progress Report for Fuel Cells for Transportation. FY 1999. October 1999.