



Comparison of Regenerative Heat Recovery Devices

Regenerative Heat Recovery Device	Specific Heat Transfer Area (m ² /m ³)	Hydrodynamic Diameter of Each Flue (m ³)	Gas Velocity (m/s)	Specific Volume (m ³ /kW @ 80% efficiency)	Outlet Air Temperature Fluctuation	Applicability to Duty Gas
Checkerbrick regenerator (blast furnace, glass tank, coke oven)	10 - 17	7.6 - 20.6	0.2 - 6	0.1 - 0.16	High, or low with lowered average temperature	Highly polluted flue gas with gas / iron oxide, alkali fume
Honeycomb regenerator (regenerative burner)	300 - 1500	0.2 - 0.4	7 - 10	0.0008 - 0.0015	Medium	Clean gas or oil combustion products
CRETAH	145	2.4	10	0.0264	Low	Moderate contamination (solids and corrosive chemicals)

Applications

The CRETAH can be applied to various industrial areas requiring high temperature exhaust recovery. These include the chemical, metallurgical, cement and ceramic sectors. The system is suitable to deal with very hot flue gases that are moderately contaminated with solid particles and corrosive chemical substances. Highly preheated combustion air with minimal temperature fluctuations is provided by this design. The compact volume allows for easy adaptation in tight spaces, particularly during retrofits. The CRETAH system also provides remarkable energy savings and CO₂ emissions reductions.

Your Invitation to Work with Us

We are interested in collaborating with you. Please contact the Business Office to discuss your particular needs.

(613) 996-8693

cetc-bdo@nrcan.gc.ca

For Further Information Please Contact:

Bruce Clements
Research Scientist
(613) 943-8881
clements@nrcan.gc.ca

CANMET Energy Technology Centre – Ottawa
Natural Resources Canada
1 Haanel Drive
Nepean, Ontario, K1A 1M1
Canada

cetc.nrcan.gc.ca



The **CRETAH (Cascading Regenerative Elevated Temperature Air Heater)** is an advanced heat exchanger system that satisfies the challenging operating conditions of many industrial combustion applications. The development of this system is underway at CANMET with support from the Climate Change Action Plan of Canada. It can facilitate many advanced combustion concepts for industrial combustion processes by providing highly preheated combustion air with the recovery of energy from hot exhaust gases. This leads to remarkable savings in energy consumption and resultant minimization of GHG emissions for many industries.

A prototype model of the CRETAH has been constructed and tested at CETC-Ottawa. The designated heat transfer efficiency (80%) for a duty of 0.1 MMBtu/hr is achieved with a very hot inlet flue gas temperature (>2730°F / 1500°C) and outlet air temperature (>2200°F / 1200°C). The innovative operational principle and structural design of the CRETAH result in advantages that allow efficient and reliable performance for various industrial applications at relatively low cost.

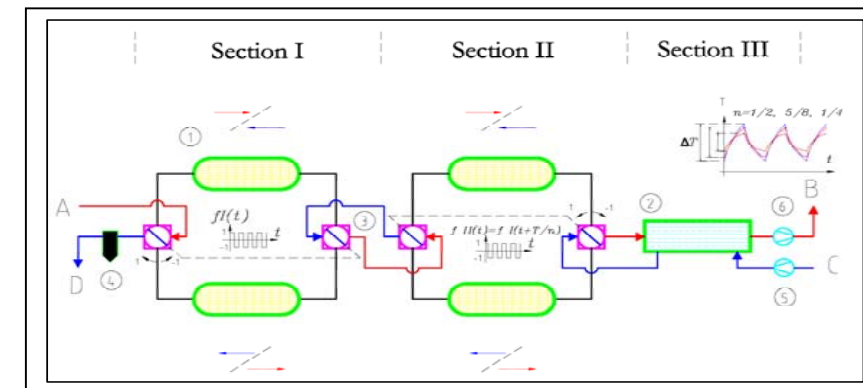

CRETAH System Schematic

- A – Inlet flue gas
- B – Exhaust
- C – Inlet Air
- D – Combustion Air
- 1 – Ceramic regenerators
- 2 – Metallic recuperator
- 3 – Valves
- 4 – Filtering system
- 5 – F.D. Fan
- 6 – I.D. Fan

Nomenclature

- Cascading** — The system is composed of sections of cascading heat transfer components, which include two pairs of ceramic regenerators and one metallic recuperator, through which the gases flow in succession.

Operated properly, this arrangement can help to reduce fluctuation of the outlet gas temperature, which is an unfavorable feature for single-stage fixed-bed regenerators.



- **Regenerative** — The regenerators, which are the main components of system, are technically superior in dealing with very hot gases compared with recuperative heat exchangers. They function as a heat storage unit, where the heat is extracted and subsequently released between the hot flue gas and cold air, as both gases flow through the regenerator alternatively.
- **Elevated Temperature** – The system is designed to handle flue gas at elevated temperature exceeding the service temperature of most metals. Such hot flue gas is often seen in many industrial combustion applications.
- **Air Heater** – The system can be integrated with various industrial combustion applications to preheat the combustion air with the exhaust flue gases. Combustion with highly preheated air is proven advantageous along with enhancing the thermal efficiency of the combustion cycle.

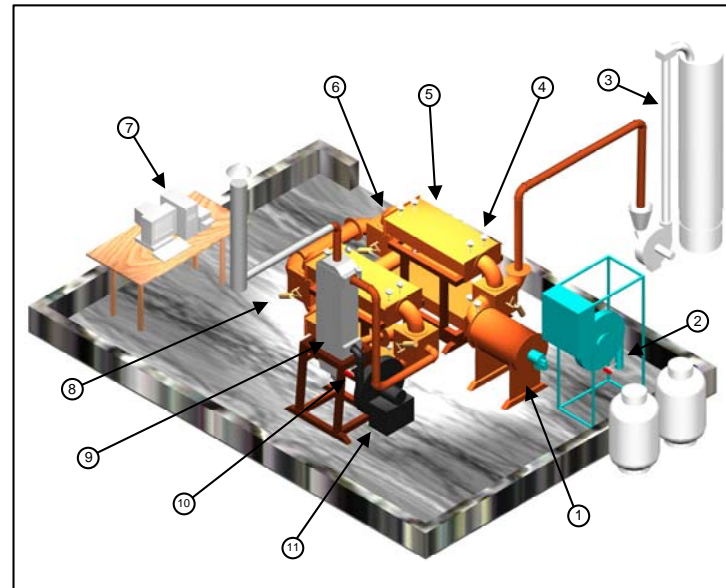

3D View of Experimental Setup

- | | | | |
|---|--------------------|----|----------------------|
| 1 | Combustion Chamber | 7 | Data logger |
| 2 | Burner System | 8 | Valve Actuator |
| 3 | Dust Collector | 9 | Recuperator |
| 4 | Thermocouple | 10 | Velocity Transmitter |
| 5 | Regenerator | 11 | Blower |
| 6 | 4-Way Valve | | |

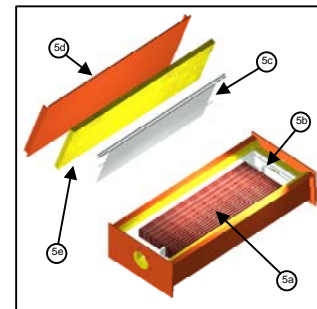

Regenerator

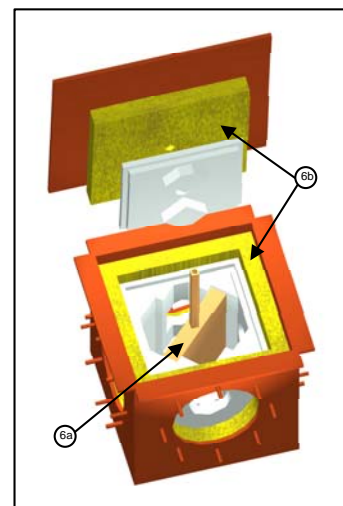

4-Way Valve

- | | |
|----|-----------------------|
| 5a | Ceramic Tile |
| 5b | Flow Director |
| 5c | Grooved Ceramic Plate |
| 5d | Shell |
| 5e | Insulating Plate |
| 6a | Damper blade |
| 6b | Insulating Plate |

Bench-Scale Prototype

The bench-scale prototype system was built as part of a general-purpose combustion test facility. The operating conditions are typical of many industrial combustion systems. Both experimental and computational studies have been done to analyze heat transfer performance. The main performance specifications are given in the table below.

Parameter	Metric Units	British Units
Heat transfer efficiency	80%	80%
Duty	30 kW	100,000 Btu/hr
Inlet flue gas temperature	1500°C	2730°F
Outlet air temperature	1200°C	2192°F
Flue gas volume	0.8 m ³ /min	28 cfm
Air volume	0.7 m ³ /min	25 cfm
Pressure drop	2.0 kPa	8 W.C.
Heat transfer area	12.6 m ²	136 ft. ²
Specific Area of HT	145 m ² /m ³	48 ft. ² /ft. ³
Cross-sectional area	0.0127 m ²	0.137 ft. ²
	(0.15 m by 0.08 m)	(5.9 in. by 3.28 in.)
Individual flue size	0.014 m x 0.083 m	0.545 in. x 3.28 in.
Average flue velocity	10 m/s	2000 fpm
Main dimensions	1.47 m x 0.41 m x 0.33 m	58 in. x 16 in. x 13 in.

CRETAH Features

- **High temperature rating**
 - Handles very hot exhaust gases (to 1500°C).
 - Ceramic heat transfer medium has superior resistance to intensive heat and thermal shock.
 - Ceramic plate cracking is the major problem for recuperative heat exchangers; this has a minimal effect on CRETAH performance.
- **Compact structure**
 - The distinctive structural design of the heat transfer medium allows for smaller regenerator dimensions.
 - The 3-pass honeycomb flow passage allows for a smaller cross-sectional area.
 - The compact volume gives ease of retrofit and improved economy.



- **Minimum fluctuation of outlet temperature**
 - Is critical for many industrial processes and burners.
 - Achieved with the unique arrangement of cascaded regenerator stages and staggered operating cycles.
 - Phase-shifted temperature swings for stages overlap to give consistent outlet temperatures.
 - Compared with conventional methods, this allows for longer switching periods with minor impact on heat transfer efficiency.
- **Applicability for polluted flue gas**
 - CRETAH runs reliably with moderately polluted flue gases containing solid particles & corrosive species.
 - The large hydrodynamic diameter of individual flue passages and reasonably high flow velocity reduce slugging and fouling.
 - Suitable ceramic materials can be substituted for specific applications (certain chemical atmospheres).
 - A filtration system can be added to clean the outlet air (slightly contaminated by entrained flue gas).