

Functionality and Allocation in a Multi-product Metals Refinery

H. von Blottnitz & J.G. Petrie

University of Cape Town
Environmental Process Engineering Research Group
Private Bag, Rondebosch, 7701, South Africa
hvb@chemeng.uct.ac.za

Environmental Process Engineering Research Group
University of Cape Town



One refinery, several metal products

- Frequently, metals are won from complex ore deposits.
- Mining and beneficiation operations thus process several eventual products together.
- Product designers want to work with the environmental impact of a single material; Process designers want to optimise each process in the life cycle.
- Allocating impacts of mining and processing operations between co-products is relatively easy in the early steps of the life cycle, but:
- complex in metal refining, owing to specific unit operations for specific metals, and the possibility of treating diverse concentrates.



From a complex ore “cradle” to the various marketable metal “gates”

the example of a base and precious metals containing ore

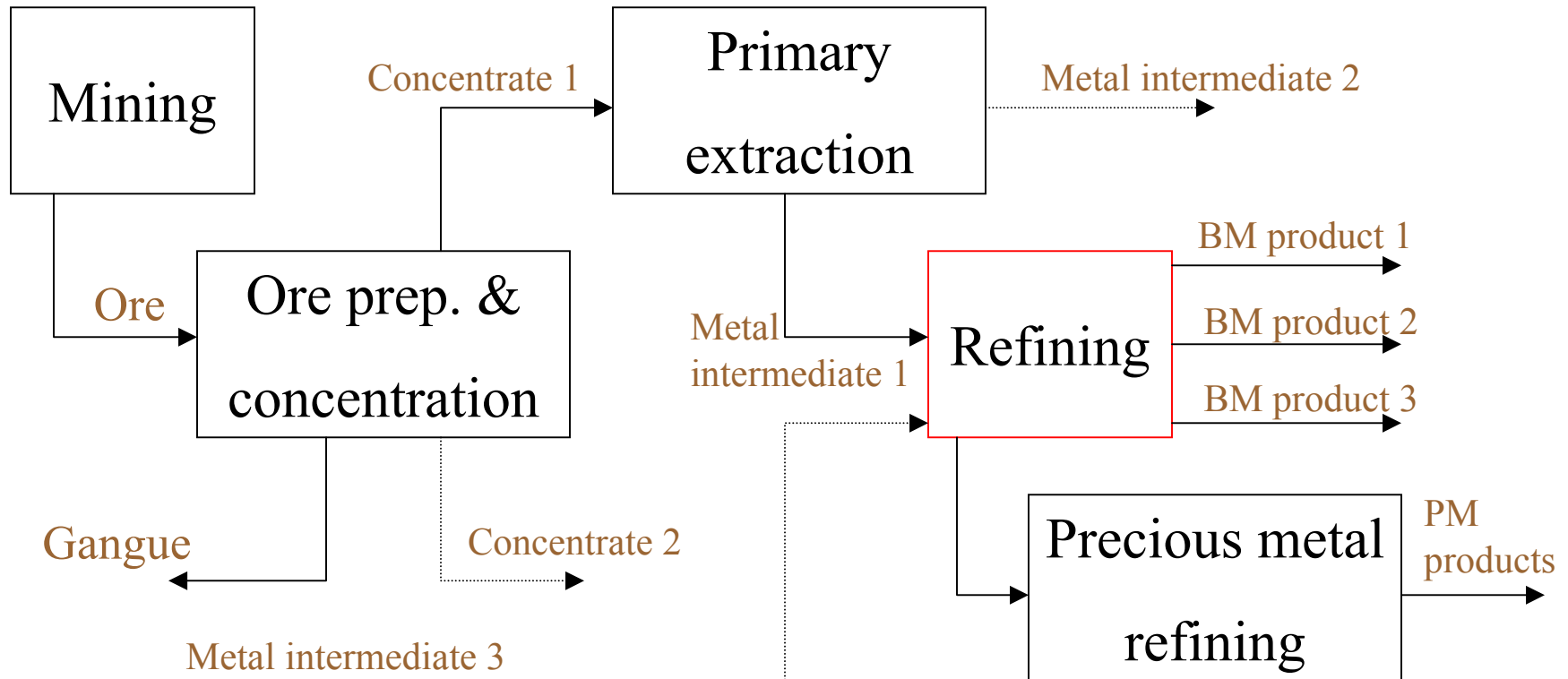

Two reasons to focus on this one step in the metals' life cycles

1. Data gathering for a metal life cycle

- e.g. for international benchmarking or inventory definition study
- Needs a reference flow.
- Functionality of lesser importance (need reference flow).
- Allocation between multiple co-products crucial.

2. Environmental considerations in refinery design and operation

- Why? To optimise life cycle environmental performance vis-à-vis life cycle costs, subject to site economic and site environmental constraints.
- Needs functionality of the facility to be understood / defined.
- Allocation of burdens between co-products of lesser importance.



Functional unit, reference flow and allocation rules used in previous studies

- Study for the Nickel Industry LCA group (type 1 above):
Ecobalance, 2000
 - Functional unit equated to reference flow
 - at 1 kg of Ni in each Ni-product
 - Allocation between different metal co-products on the basis of mass of different metals in the product stream(s) from each operation
- LCA for a base metal refinery (type 2 above)
Forbes et.al., 2000
 - Functional unit set at 1 ton of Ni metal produced
 - “on basis of quantity (70% of base metal output) and revenue generated (80% of BMR revenue)”
 - No allocation needed by virtue of goal definition



A base metal refinery and its life cycle

Forbes et.al., 2000

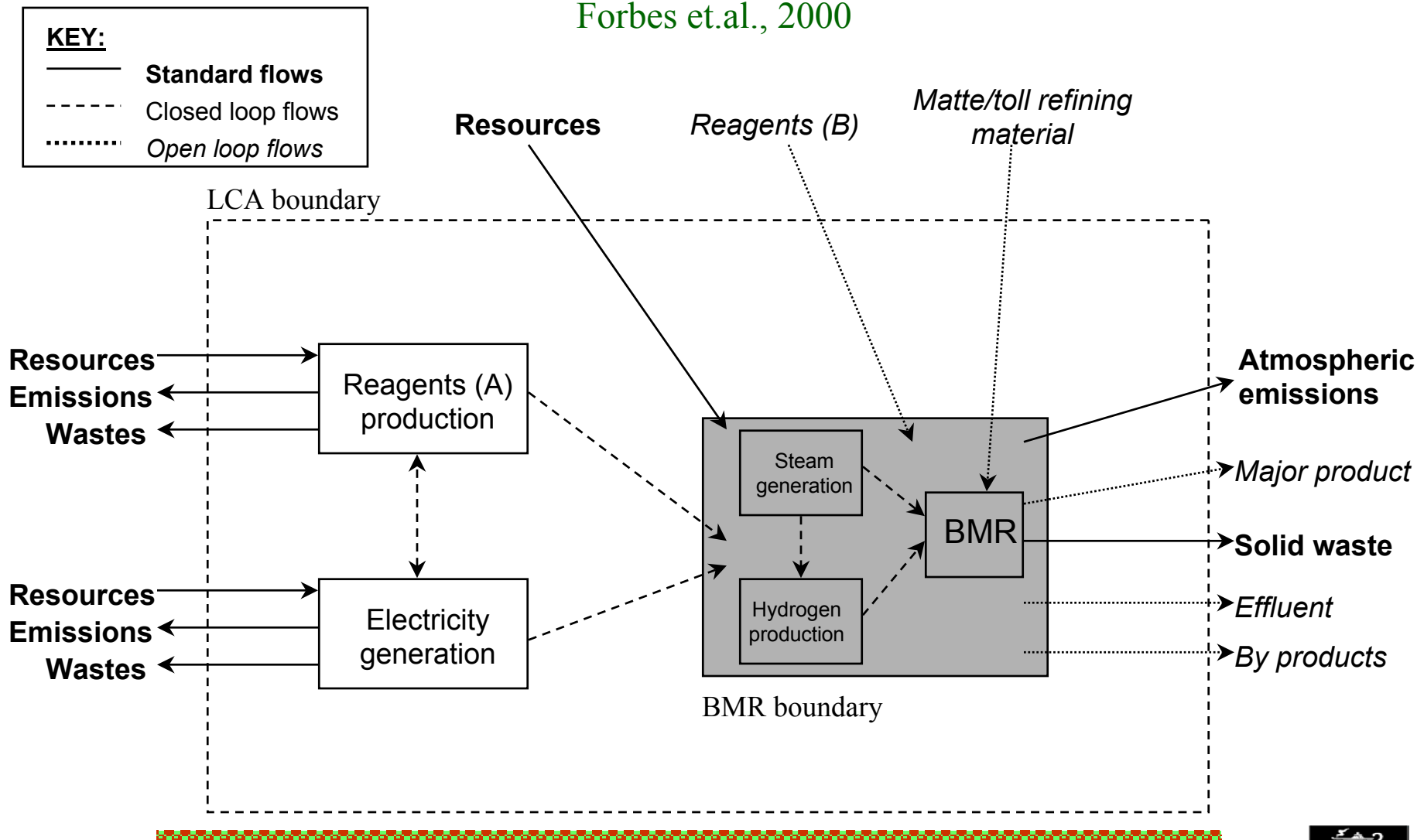

Inside a Base Metals Refinery

Forbes et.al., 2000

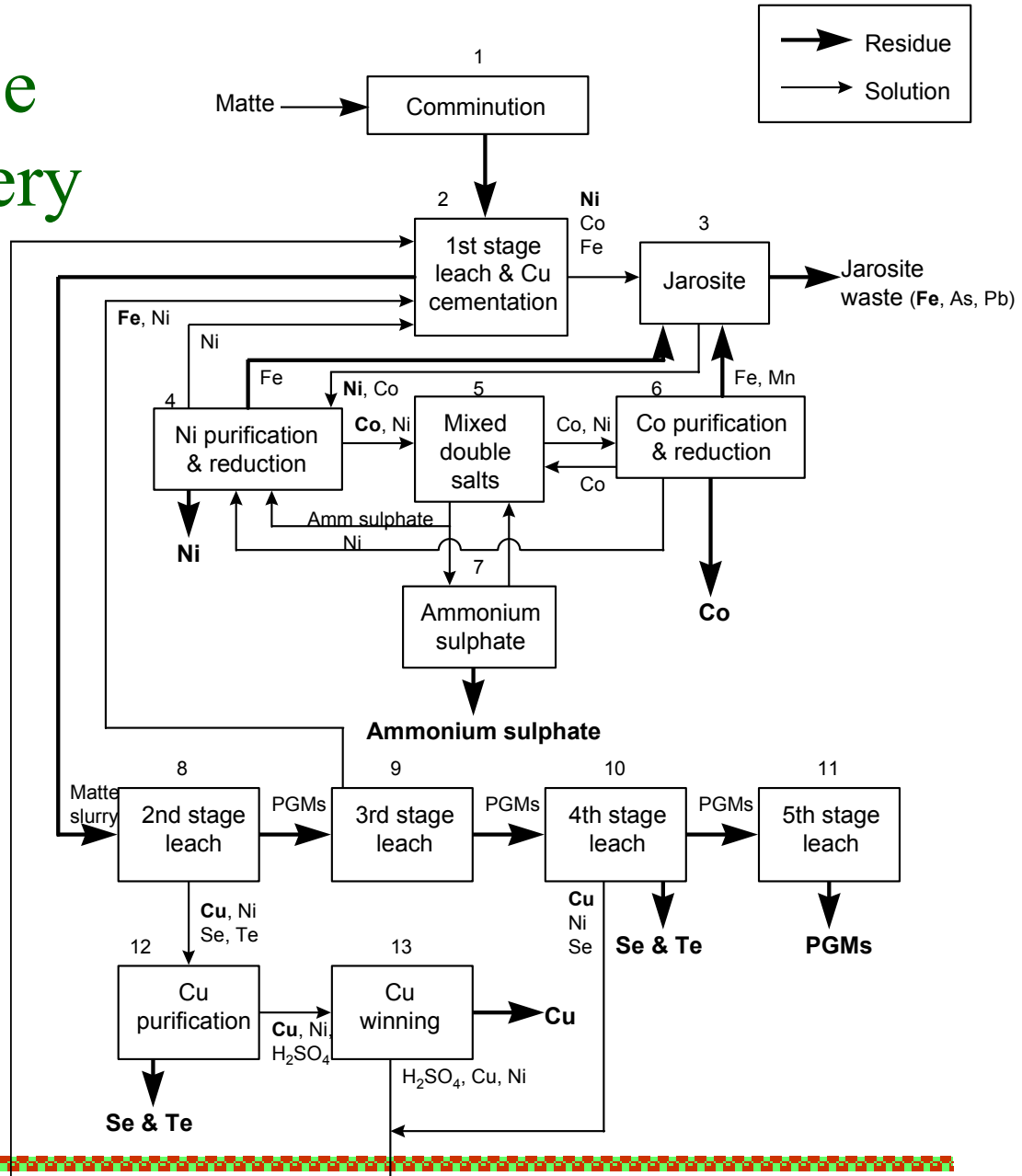

Functionality and Functional Unit as they guide Design and Management

- To illustrate how an understanding of functionality guides the designer/manager, consider a hypothetical case:
 - 6 options for a design/operational parameter (a-f)
 - trade-off between Ni-recovery and PGM non-recovery
 - every extra 1% Ni equates to 0.01% more PGM loss
 - ore contains 1000 mass units of Ni per mass unit of PGM
 - higher Ni recovery obtained at cost of higher energy needs
 - 5% higher GWP for every 1% extra Ni recovered
 - results graphed below
- When f.u. 1 ton of Nickel:
 - economical target at f, environmental target at a
- When f.u. an approximation of value added
 - both economic and environmental targets at a



Choice of functional unit for a Ni refinery with PGM recovery

- hypothetical case based on PGM:Ni tonnage price ratio 10,000 -

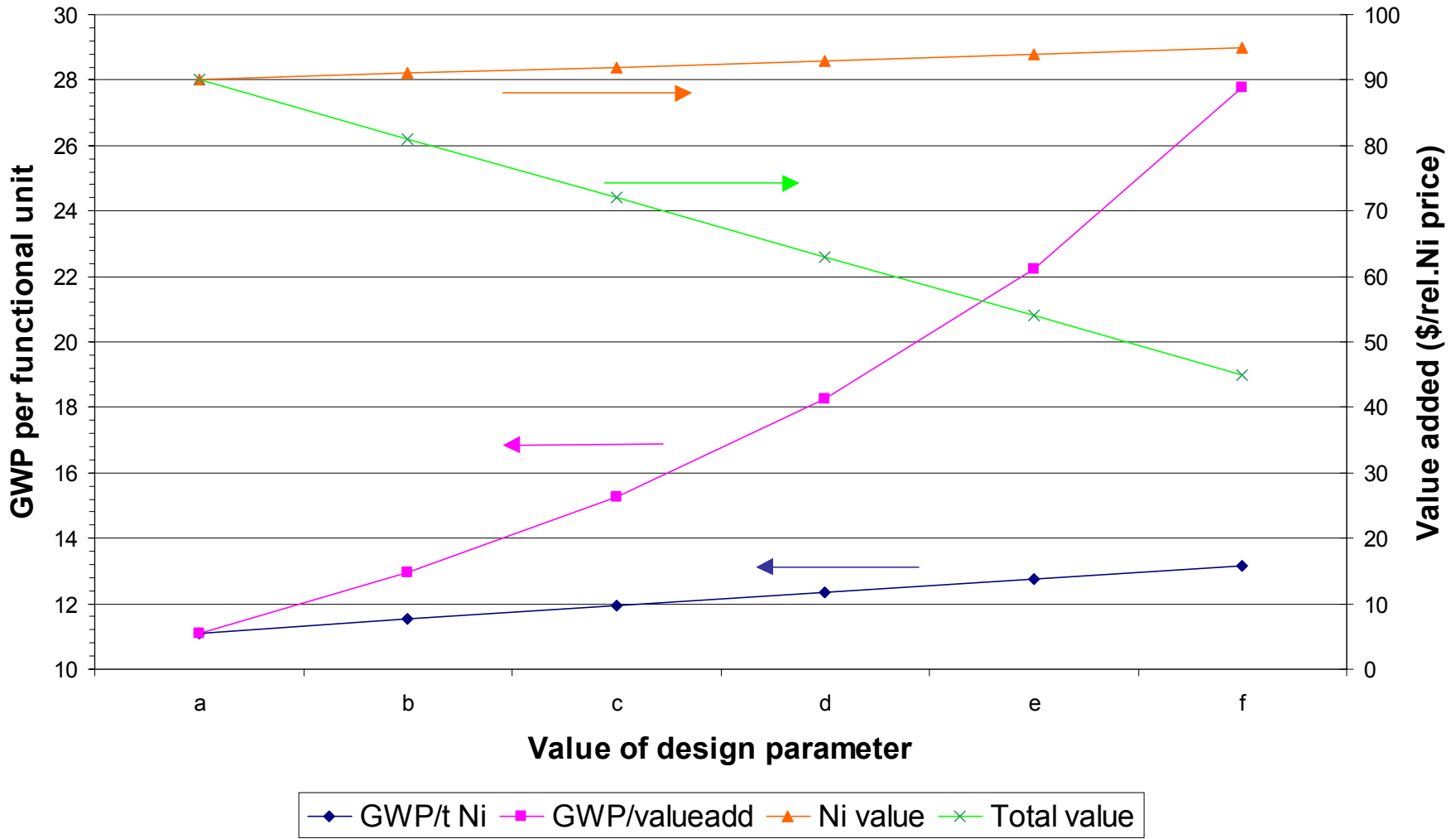

A closer look at allocation rules in systems involving base and precious metals

- Mass ratio of BM:PM is 1000:1, value ratio is 10:90
- Clearly then, all stages to the gate serve primarily the precious metals
- But some sub-stages within the refinery may exclusively serve base metals
 - e.g. steps 4, 6, 12 & 13 above
- It is theoretically possible to partition the refinery system
 - but requires very detailed monitoring, or a detailed design simulation
- Even then, what if a common utility responds poorly to turndown? (see graph below)



The effect of a design parameter (turndown) on linearity of impacts w.r.t. reference flow

The relationship between the greenhouse effect impact category and nickel production (Forbes, 1999)

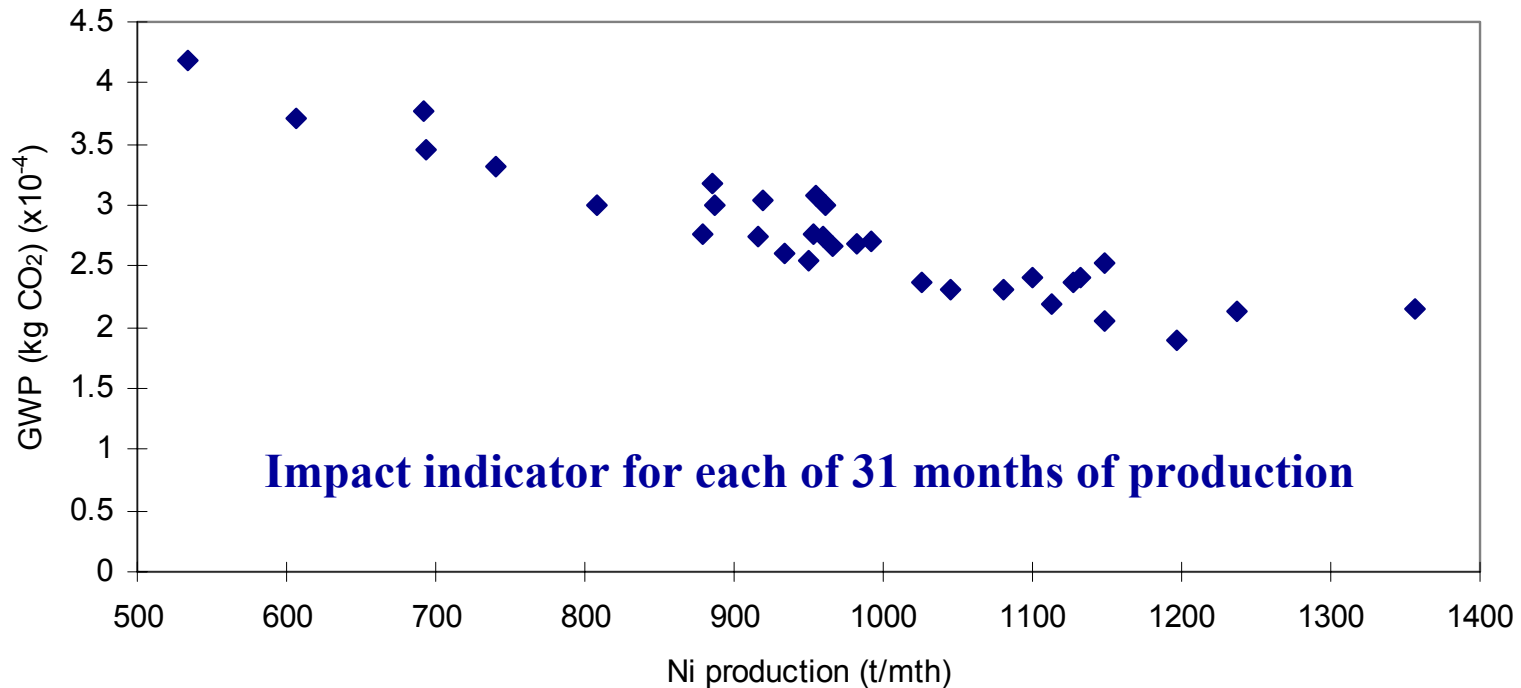

Discussion

- Value-based allocation in systems involving PGM would mean superior environmental profile of base-metal co-products out of these systems over their competitors?

Conclusion

- Ability to define function of a processing plant correctly is crucial to rational multi-criteria optimisation.
- Allocation rules in mixed BM/PM systems have a large impact on results.



References

- Ecobalance Inc., “Life Cycle Assessment of Nickel Products”; Final Report for the Nickel Industry LCA Group, November 2000.
- P. Forbes, H. von Blottnitz, P. Gaylard and J.G. Petrie, “Environmental Assessment Of Base Metal Processing: A Nickel Refining Case Study”, *SAIMM Journal Transactions*, 100 (6), pp. 347 – 353; 2000.
- P. Forbes, “The Use of Life Cycle Assessment in the Evaluation of Environmental Performance in the Base Metal Refining Industry”; M.Sc. thesis, University of Cape Town, 1999.

