

**L I A I S O N**

**TITLE:** NRIC V Focus Group 3 – Final Report and Recommendations  
**SOURCE\*:** T1E1 Chair  
**PROJECT:** T1E1-38  
**DISTRIBUTION:** TSC T1E1 & WG T1E1.4

---

**ABSTRACT**

This contribution contains the Final Report and Recommendations of the Network Reliability and Interoperability Council's Focus Group 3 "Wireline Network Spectral Integrity". It contains the seven recommendations and the "Remote Deployments of DSL: Advantages, Challenges and Solutions" White Paper. This report was approved by the full council of NRIC on January 4, 2002. It is provided to T1E1 and T1E1.4 for the information of, and possible discussion by, T1E1.4 at the February 18-22, 2002 meetings in Vancouver, BC.

---

---

**NOTICE**

This is a draft document and thus, is dynamic in nature. It does not reflect a consensus of Committee T1-Telecommunications and it may be changed or modified. Neither ATIS nor Committee T1 makes any representation or warranty, express or implied, with respect to the sufficiency, accuracy or utility of the information or opinion contained or reflected in the material utilized. ATIS and Committee T1 further expressly advise that any use of or reliance upon the material in question is at your risk and neither ATIS nor Committee T1 shall be liable for any damage or injury, of whatever nature, incurred by any person arising out of any utilization of the material. It is possible that this material will at some future date be included in a copyrighted work by ATIS.

---

# **NRIC V**

**Network Reliability and Interoperability Council**

Focus Group 3

Wireline Network Spectral Integrity

Final Report and Recommendations

January 4, 2002

**Ed Eckert**, Chair, Focus Group 3

**Phil Kyees**, Chair, Spectrum Management Subcommittee

**Massimo Sorbara**, Chair, Spectrum Compatibility Subcommittee

# Focus Group 3 – Accomplishments Through the Term of the NRIC V Charter

- 25 days of face-to-face meetings;
- 9 Conference Calls;
- 106 contributions registered and considered;
- 7 Liaisons to key standards development organizations;
- 7 Recommendations developed and approved;
- One White Paper developed and published.

# Title & Mission Statement

- NRIC V, Focus Group 3 shall be Titled

## ***“Wireline Network Spectral Integrity”***

- The Mission of the *Wireline Network Spectral Integrity* (WNSI) Focus Group is to provide recommendations to the FCC and to the telecommunications industry that, when implemented, will:
  - ensure the integrity of coexisting services in wireline public telecommunications networks;
  - facilitate widespread and unencumbered deployment of xDSL and associated wireline high speed access technologies, and;
  - encourage network architecture and technology evolution that safeguards the integrity of wireline public telecommunications networks while maximizing capacity, availability and throughput in an unbundled/competitive environment.

# Contribution Categories

- Intermediate TU Issues
  - Repeaters in the loop plant **Ö**
  - Spectrum Compatibility of Digital Loop Carrier (DLC) based signals with Central Office (CO) based signals **Ö R WP**
  - Effect of Intermediate TU-Cs **Ö R WP**
  - Multiple Locations **Ö R WP**
- Administration of Loops and Technologies in Binders
  - Grandfathering vs. Sunsetting services/technologies **Ö**
  - Measuring and reporting if particular loop is qualified for a specific spectrum management class (loop length, bridge taps) **Ö**
  - Measuring & Reporting Loop Parameters for use in xDSL Loop Qualification **Ö R**
  - Equivalent Working Length (EWL), Loop Length, Bridged Tap **Ö**
  - Reporting Technologies **Ö R**
  - Definition of Known Disturbers **Ö**
  - Bi-directional Disclosure of Spectrum Management Class and PSD **Ö R**
  - Effectiveness of rules and mechanisms for binder group management and interference in dispute resolution **Ö R**
- Equipment Registration
  - Application of Part 68 to xDSL TU-R (Customer Located Equipment) **Ö R**
  - Certification/registration of xDSL TU-C Equipment to published Technical Requirements **Ö R**
- New Technology
  - Frequency Planning for advancement of high-speed services in the loop plant **Ö R**
  - Short Term Stationary Systems **Ö R**
  - xDSL technology evolution to promote long term spectral integrity **Ö**
- Line Sharing
  - POTS Quality **Ö R**
  - Data Quality
  - Metallic Test Access **Ö R**
  - Fault Management **Ö R**
  - Splitter Ownership **Ö**
  - Splitter Physical and Electrical Location **Ö**
- Ingress/Egress issues
  - Metallic Balance in Network and Customer wiring **Ö**
  - Effect of In-premises Signals on Wireline Network **Ö R**
  - In-Premises Wireline Transmitters **Ö R**
- Co-Located TU Compatibility
  - Spectrum Compatibility of Co-located xDSL Transceivers **Ö R WP**
  - TU-Cs at CO **Ö R WP**
  - TU-Cs at RT **Ö R WP**

**Ö = Discussed/Presented; R = Resulted in Recommendation; WP = Included in White Paper**

# SME's & Sponsor Organizations

- Service Providers
  - AT& T: Brad Beard
  - BellSouth: Gary Tennyson
  - Covad: David Rosenstein
  - Qwest: Jamal Boudhaouia
  - Rhythms: David Reilly
  - SBC: Gene Edmon
  - Sprint: Pete Youngberg
  - Verizon: Greg Sherrill
  - WorldCom: Paul Donaldson
- FCC
  - Paul Marrangoni
- Equipment Suppliers
  - Adtran: Kevin Schneider
  - Elastic Networks: Patrick Stanley
  - Lucent: John Unruh
  - Texas Instruments: Thomas Maudoux
- Leadership
  - Catena Networks: Ed Eckert
  - GlobeSpan: Massimo Sorbara
  - Paradyne: Phil Kyees
- Previous Participants
  - Anjali Joshi, Mary Retka, Roger Smith, Jim Earl, John Roquet, Peter Krautle, Phil Crispino, Tom Shen, Harry Mildonian, Jim Carlo

# Status of Technical Standards Development and Implementation

- Committee T1's Technical Subcommittee T1E1 completed the first T1.417 "American National Standard - Spectrum Management for Loop Transmission Systems", approved by ANSI on 1/1/2001. Available at [www.atis.org](http://www.atis.org).
- Standards for Inline Filters (for splitterless DSL) as well as G.shdsl pointer have been approved by Committee T1 & sent to publication.
- Standard for Network End Splitters to be balloted by T1 in November.
- VDSL standards for trial use are now out to Committee T1 for a second default letter ballot and comments from this ballot will be considered at the February T1E1 meetings.
- Effort on Dynamic Spectrum Management (DSM) is well under way.
- Joint work between T1E1.4 and TR41.9 on ACTA (Part 68) issues:
  - T1E1.4 will be responsible for developing a recommendation on the installation of ADSL splitters in homes having alarms/security systems. Call for contributions has been made and some have already been considered by the group.
  - Joint work to identify appropriate sections of T1.417 "Spectrum Management" for inclusion in a future issue of TIA-968.

# Status of Technical Standards Development and Implementation

- T1E1.4 continues work on Issue 2 of T1.417, with discussions and contributions being focused on the spectral compatibility of Central Office based DSL with Remote Terminal based DSLs and Repeaters (a.k.a “intermediate transceiver units” (TUs)).
- Target is to have draft Issue 2 out for letter ballot in 2Q2002.
- Format (i.e. delta document, addendum, or a completely new version) for Issue 2 is not yet clear, however any changes will be normative.
- Topics for consideration in Issue 2 include:
  - Revision of non-DSL out-of-band metallic and longitudinal signal power limits to provide an adequate level of protection for DSL systems.
  - Addition of VDSL to the basis systems list.
  - Extension of spectrum management class 5 upstream band to lower frequencies.
  - Methods for optimizing PSDs, maximizing throughput and binder group capacity.
  - Trade-offs between loop length guidelines and spectral characteristics.
  - The susceptibility of some deployed systems to short term stationary crosstalk.
  - Spectral compatibility with T1.419 (splitterless ADSL) basis systems.



# Status of Technical Standards Development and Implementation

- The DSL Forum is an industry forum formed to promote the deployment of DSL technologies. It is composed of carriers, vendors, test laboratories and other companies and organizations with interest in promoting DSL deployment. The DSL Forum is currently involved in several DSL related projects:
- **Interoperability Testing** – The DSL Forum is developing DSL interoperability test plans, including an ADSL interoperability test plan that can be used to verify interoperability between different vendors’ ADSL products.
- **Independent Test Labs** – The Forum is sponsoring the recognition of independent testing laboratories that can perform and report on standardized interoperability testing between vendor DSL products.
- **Trade Show Demonstrations** – The DSL Forum is sponsoring demonstrations of DSL Interoperability at various telecommunications industry trade shows.
- **Emerging Technologies** – The Forum is supporting work related to several emerging technologies including VDSL, Voice over DSL and SHDSL
- **DSL Everywhere** – The DSL Forum is documenting DSL technologies that can be used to provide high-speed data service to “hard to reach” customers on long loops.
- **Flow-Through Provisioning** – The DSL Forum has developed a model to enable the standardized end-to-end exchange of information required for the provisioning of DSL service.
- **Auto-Configuration** – The Forum is developing recommended procedures to automatically configure connections between Customer Premises Equipment and Internet Services, focusing on the requirements across the DSL local loop.
- **DSL Marketing** – The DSL Forum promotes public awareness of DSL and communicates the advantages of DSL technologies.

# Recommendations

- Focus Group 3 has produced seven Recommendations and one White Paper during its charter.
- The seven recommendations, as approved, and the white paper are attached as Appendices 1 thru 8 of this report.
- The next few slides offer some information on the actions taken towards the implementing the recommendations.

# Status: FG3 Recommendations #1 - #2

- **Rec #1 - New Technology, Frequency Planning:**
  - Revision to original recommendations approved in Feb 2001.
  - Means of “FCC Endorsement” of Band Plan 998 is still unclear, however FG3 encourages FCC acknowledgement and consideration of this recommendation in future orders.
  - Band Plan 998 will be included in Issue 2 of T1.417.
- **Rec #2 – Ingress/Egress Issues; In-Premises Wireline Transmitters:**
  - The ITU-T is developing technical requirements for an isolation device; it is presumed that such technical requirements would be adopted by a US standards development organization.
  - FG3 wishes to encourage the development of these technical requirements and FG3 encourages FCC acknowledgement and consideration of this work in future orders.

# Status: FG3 Recommendations #3 - #4

- **Rec #3: - Equipment Registration, Application of Part 68 to xDSL TU-R (Customer Located Equipment):**
  - **Formation of ACTA (Administrative Council on Terminal Attachments) completed;**
  - **Part 68 Technical Requirements now contained in TIA IS-968.**
  - **Committee T1 "Technical Requirements for SHDSL, HDSL2, HDSL4 Digital Subscriber Line Terminal Equipment to Prevent Harm to the Telephone Network" is now published.**
- **Rec #4 - Intermediate TU Issues:**
  - **T1E1 needs to revisit this recommendation and expedite contributions towards T1.417 Issue 2 to bring resolution to this issue.**

# Status: FG3 Recommendations #5 - #6

- **Rec #5: - Line Sharing Test Access**
  - **FG3 encourages FCC acknowledgement and consideration of this recommendation in future orders.**
- **Rec #6 - Intermediate TU Issues – Remote DSL:**
  - **Recommendation prepared by FG3 was partially approved in February (the approved portion is in Appendix #6 of this report);**
  - **One part of the originally proposed recommendation was remanded to FG3 for further consideration;**
  - **Since no consensus on the language for one aspect of the recommendation could be attained, it was agreed that a white paper would be produced. The white paper is now complete and attached to this report.**

# Status: FG3 Recommendation #7

- **Rec #7 - Exchange of spectrum management information between loop owners, service providers and equipment vendors:**
  - Recommendation originally provided to the council for approval in October 2001, however it was remanded to the FG for minor corrections. It was subsequently approved by correspondence.
  - The Recommendation contained a placeholder for additional information on voice grade loop parameters. Thanks to T1E1.3, these were received and agreed to be included in Annex A of the revised recommendation.
  - Attached is the final, revised version of Recommendation #7, as approved by correspondence.
  - FG3 encourages FCC acknowledgement and consideration of this recommendation in future orders. Consideration should be given to referencing a future publication of Committee T1 in lieu of Annex A.

# White Paper

- **Since no consensus could be attained on a solution for the friendly coexistence of CO-based and remote DSL deployment (Recommendation #6 remand), it was agreed that a white paper would be produced.**
- **White Paper: “Remote Deployments of DSL: Advantages, Challenges, and Solutions” is now completed and is attached to this report as Appendix # 8.**
- **FG3 encourages FCC acknowledgement and consideration of this white paper in future orders.**

# White Paper Abstract

“This paper addresses the wireline network spectral integrity challenge created when DSL transceivers are deployed at locations remote from the central office (CO) yet within the potential reach of CO-based DSL transceivers. It discusses background, technologies, architectures and major issues surrounding the evolution of the telecommunications access network as they relate to remotely deployed DSL transceivers and wireline network spectral integrity.

The paper aims to assist the FCC and the industry in managing this very complex and difficult problem by promulgating a consistent understanding of the underlying issues. It offers options for possible solutions for deployment of CO-based systems in the presence of remote DSL transceivers. This paper does not address repeatered systems.

All of the members of NRIC-V Focus Group 3 agreed to the inclusion of all of the material in this paper. There is no consensus, however, on the extent to which any of the benefits, challenges or possible solutions will affect the industry’s ability to provide the consumer with more advanced service choices (type and supplier) while maintaining wireline spectral integrity in a competitive, cost-effective, and business-driven manner.”



# EWL Work Item

- An additional work item in FG3 was a study to determine if a useful correlation could be found between EWL (Equivalent Working Length) derived from actual physical loop make up and that which was approximated by using capacitive-measured loop length from automated loop test systems currently in the network.
- Loop EWL is needed to determine what services are spectral compatible on that loop:
  - Calculation of EWL requires knowledge of physical loop makeup, however such information is not readily available in many regions
  - A fast, economical method to determine EWL would benefit all consumers seeking DSL services.
- The FG has been gathering EWL calculated from loop makeup as well as capacitive-measured loop length for thousands of pairs from various loop owners. Obtaining and processing enough data to study correlation has been a challenge.
- The FG can not yet determine if correlation will be tight enough to provide reasonable approximation, or what form the approximation would take, in order to make a recommendation. Further study is recommended.

# Special Thanks To:

- Young Carlson, FCC Administrative Assistant for her excellent work on meeting logistics.
- Kent Nilsson (FCC OET), Designated Federal Officer to NRIC V, Paul Marrangoni (FCC OET), Jessica Rosenworcel (FCC CCB) and all of the commission's staff for their ongoing guidance on, and encouragement of, Focus Group initiatives.
- Doug Sicker, Staci Pies and the NRIC V leadership team from Level 3.
- All of our meeting hosts.
- Our volunteer Subject Matter Experts and their sponsor organizations, especially those who have taken on extra assignments.

NRIC V Focus Group 3  
Wireline Network Spectral Integrity

Final Report and Recommendations

January 4, 2001

**Appendix 1**

**Recommendation # 1**  
**(Final version as revised and approved)**

# Recommendation #1: Frequency Planning

## **Background:**

The construction of the telephone loop plant cables results in the coupling of signals from one pair to another. This coupling, known as crosstalk coupling, is one of several factors that limit the information delivery capacity of the twisted-pair loop plant. Spectrum Management is the name given to the complex problem of managing the effect of crosstalk coupling in a manner that results in effective use of the loop plant.

In the lower-frequency portion of the loop plant (less than approximately 1 MHz) the spectrum management process accommodates several overlapping ways of using the spectrum: frequency division duplexed (FDD), full-duplex echo-canceled (EC), time-division duplexed (TDD) and their various combinations.

FDD systems achieve their rates and performance by splitting the available frequency spectrum into portions reserved for upstream transmission and other portions reserved for downstream transmission, thereby effectively eliminating self Near-End Crosstalk (self-NEXT) as an impairment, and leaving the lower self Far-End Crosstalk (self-FEXT) as the dominant impairment. With FEXT limited systems, power backoff mechanisms are required to keep FEXT below the design limit when transmitters on nearby pairs are not all co-located. Because of the allocation of frequencies to either upstream or downstream, FDD frequency plans are optimal only for a particular service data rate.

EC systems use roughly the same spectrum for simultaneous transmission in both directions on the loop. They are usually employed to deliver symmetric service. In the US, Basic Rate ISDN, SDSL, HDSL and HDSL2 are examples of widely deployed EC systems. EC systems are usually performance limited by self-NEXT when all systems deployed in nearby loops are using approximately the same transmit power.

TDD systems transmit in the different directions on the loop at different times, thus minimizing self-NEXT. Therefore, they become performance limited by FEXT and crosstalk from other systems.

While simultaneous deployment of systems employing the various duplexing methods has been accommodated when using the lower frequency portion of the loop plant, this becomes more difficult at the higher frequencies, where the crosstalk coupling is greater. VDSL, which has been identified by the industry as a viable means for delivering multi-megabit advanced services over relatively short local loops, transmits in these higher frequencies. The industry has selected a FDD approach for transmitting data bi-directionally over a single pair. In order for these systems to attain their designed data rates, all transceivers which share nearby pairs in a cable must adhere to the same basic frequency plan.

The T1E1.4 working group of Committee T1 has spent considerable effort trying to develop a VDSL band plan to accommodate the wide range of potential service offerings made possible by the technology. In the end, it was decided that consumer video delivery was the most important application and that the VDSL band plan should emphasize asymmetric data rates to best accommodate video delivery, while also allowing a reasonable rate of symmetric service as well.

It should be noted that an area of current research is that of treating the loop plant as a multiple-input multiple-output system and using the additional knowledge to cancel a substantial amount of the crosstalk between systems. These techniques are of substantially lower complexity when all of the transmit symbol clocks are frequency locked to a common reference.

### **Recommendations:**

- 1) T1E1 has selected a single high-frequency band plan (known as FSAN 998) for frequencies from 0.138 to 12 MHz for use in the VDSL draft trial use standards, after substantial efforts to optimize it for multiple service types. FG3 acknowledges the selection of this plan and recommends that this good work be recognized and supported by the FCC as the default high-frequency band plan for use in the United States.

- 2) We recommend that T1E1 define PSD levels, transmit power limits, and spectral compatibility criteria for signals that support this default band plan (FSAN 998). These parameters should be specified for both the central office and customer premises locations.
- 3) FG3 further recommends that T1E1 include the determined PSD levels, transmit power limits, and spectral compatibility criteria in the second issue of the SM standard for protecting systems using frequencies 1.1 MHz to 12 MHz from harm. The development of the spectral compatibility criteria should assume that only Plan 998 systems utilize frequencies 1.1 to 12 MHz.
- 4) The following pertains to systems that do not follow the default band plan (FSAN 998) in the frequencies from 1.1 to 12 MHz:
  - Frequency agile technologies may deviate from this plan if they continuously monitor and default to the FSAN 998 plan if they are coupled to technologies adhering to the plan.
  - Systems not complying with the default band plan must show spectral compatibility per a compliance criteria (see #3 above) determined for the default plan. This requires that Annex A in the next issue of the SM standard contain the compatibility criteria of item #3 to show spectral compatibility in the frequencies of 1.1 to 12 MHz.
- 5) FG3 is evaluating the use of an alternative band plan under controlled or limited deployment scenarios.

NRIC V Focus Group 3  
Wireline Network Spectral Integrity

Final Report and Recommendations

January 4, 2001

**Appendix 2**

**Recommendation # 2**  
**(Final version as approved)**

# Recommendation #2: Ingress/Egress Issues; In-premises wireline transmitters

## **Background & Key Learnings:**

- Signals from home networking systems sharing the public network connected home wiring can leak into the network, which can potentially impact network based services.
- VDSL will utilize frequencies from 0.138 MHz to 12 MHz.
- HomePNA (G.pnt.f) systems on phone lines use frequencies from 5.5 MHz to 10 MHz.
- FCC Part 68 rules for out of band signal power of network connected CPE only apply up to 6MHz.

**Recommendation:** With respect to isolation devices, FG3 recommends that:

- open standards development organizations (T1E1/TR41) develop technical requirements for isolation devices that isolate in-premises networking signals (e.g. G.pnt.f) from the public network;
- the devices allow network signals to pass into the premises for frequencies up to approximately 5MHz;
- the isolation devices be customer installable;
- the use of isolation devices for in-premises systems operating above 6 MHz be mandated.

## **Expected means and timing of implementation:**

- FCC should recognize these recommendations in next appropriate Report & Order.



NRIC V Focus Group 3  
Wireline Network Spectral Integrity  
Final Report and Recommendations

January 4, 2001

**Appendix 3**

**Recommendation # 3**  
**(Final version as approved)**

# Recommendation #3: Equipment Registration, Application of Part 68 to xDSL TU-R (Customer Located Equipment)

## **Background & Key Learnings:**

- FCC Part 68 rules are for registration of Customer Premises Equipment to prevent harm to the network
- Current Part 68 rules and/or Form 730 did not anticipate, and do not adequately address the customer connected equipment used for advanced services, such as xDSL technologies.

## **Recommendation:**

- FCC Part 68 to be updated to address these needs via the responsible Technical Standards Development Organizations (TIA TR41 and Committee T1 TSC T1E1) on a fast track.
- “Part 68 Streamlining” in CC Docket 99-216 should be expedited in order to promulgate a system that will ensure that rules can keep pace with technology development.

## **Expected means and timing of implementation:**

- FCC should provide rapid decision on CC Docket 99-216, with immediate assignment of a priority work item to ensure inclusion of xDSL Remote Transceiver Units in Part 68.

NRIC V Focus Group 3  
Wireline Network Spectral Integrity  
Final Report and Recommendations

January 4, 2001

**Appendix 4**

**Recommendation # 4**  
**(Final version as approved)**

# Recommendation #4: Intermediate TU Issues

## **Background & Key Learnings:**

- Some loop transmission system technologies can be deployed in a manner that places Transceiver Unit (TU) devices as intermediate points between the Central Office (CO) and Customer Interface (CI), which substantially increases the likelihood of crosstalk interference.
- Systems with intermediate TU devices are being deployed today without any industry agreed, standardized spectral compatibility guidelines.

## **Recommendation:**

- FG3 recommends that Technical Subcommittee T1E1 address this issue immediately and aggressively.

## **Expected means and timing of implementation:**

- October interim meeting of T1E1 to send draft Spectrum Management standard to default letter ballot with inclusion of the consensus agreed definition of the tools necessary to determine the level of interference that intermediate TUs introduce into the loop plant (agreed to add annex for calculating Intermediate TU crosstalk). November T1E1.4 meeting to begin to develop text for inclusion of spectrum management guidelines in the second version of this standard, with the intent to have this version approved (by Committee T1) not later than mid 2001.

NRIC V Focus Group 3  
Wireline Network Spectral Integrity  
Final Report and Recommendations

January 4, 2001

**Appendix 5**

**Recommendation # 5**  
**(Final version as approved)**

# Recommendation #5: Test Access

## **Background and Recommendations:**

Regarding Rule 47 CFR 51.319(h)(7)(i):

1. While some manually accessed, direct physical test points (provided solely for the purpose of manual test access) have been made available by some loop providers, it is the view of FG3 that this is not a scalable solution and should NOT be required. While it is presumed that such access will continue to be made available by some loop providers to some service providers, we believe that it should be driven by private negotiation between loop owner and loop user ONLY as a matter of business convenience, and not required by rule. Further, such implementations currently in existence should be grandfathered as meeting the requirements of 51.319(h)(7)(i).

2. FG3 feels that the rule, and moreover, its underlying purpose, is sufficiently met with an automated data interchange (e.g. via terminal emulation, web-based interfaces, electronic bonding, etc.) using the voice switch-based mechanized loop testing system, assuming the following conditions:

2.1. The loop provider should assure that the line-shared loop, when provisioned, is unloaded (See 47 CFR 51.319(h)(5)).

2.2. Some mechanism shall be provided to indicate that a line sharing provisioning order has been completed. One means of satisfying this requirement is to show that the wiring between the voice switch and splitter is completed, which may be accomplished by recognition of the ADSL splitter signature (as provided for in T1.413-1998, Annex E), via the voice switch-based mechanized loop testing system. It is important to note that other means to achieve this end may be available. It is recognized that not all voice switch-based mechanized loop testing systems are currently capable of detecting and reporting splitter signature information. It is understood that such capability would require upgrades to the software for the test heads as well as for the operational support systems of the providers involved. Software upgrades for the most commonly deployed test heads are understood to be currently available. For successful implementation and

utilization of this method, it is necessary that the costs of these upgrades be recognized and that the loop provider's need to recover these costs be addressed by the FCC and state commissions.

3. DSL service providers can optionally provide their own test access, using their own POTS splitters, and their own access equipment, and their own test equipment. In any case, the DSL service provider's testing shall not interrupt an active telephone call without the end-user's permission.

NRIC V Focus Group 3  
Wireline Network Spectral Integrity  
Final Report and Recommendations

January 4, 2001

**Appendix 6**

**Recommendation # 6**  
**(Final version as revised and approved)**



# Recommendation #6: Intermediate TUs – Remote DSL

## **Introduction:**

The following FG3 recommendations are based on the following premise: “We believe that there is consumer value in Central Office DSL deployment. We also believe that future consumer value will rely upon establishing a framework for migrating the TU-C closer to the customer via broadband transport. Such a framework must provide the consumer with more advanced service choices (type and supplier) while maintaining wireline spectral integrity in a competitive, cost-effective, business-driven manner”.

## **Background and Discussion:**

- A. While the performance of a Central Office (CO)-based NEXT limited DSL system (e.g. SDSL, G.shdsl, HDSL) is little affected by the increased FEXT coupling from remote DSL deployments, performance of CO-based ADSL systems may be significantly reduced when crosstalk from remote ADSL deployments is encountered. This crosstalk may be seen when customers whose loops are in the same distribution cable are served both from CO-based and remote ADSL deployments. The expected rate of occurrence of this condition is not yet fully known, but is expected to vary from region to region and even locality to locality.
- B. These potential spectral compatibility problems can be significantly reduced (if not eliminated) by moving the appearance of all ADSL TU-Cs that serve the same distribution cable to the same location. Several techniques have been identified for moving all ADSL TU-C appearances to the remote location. These include the use of derived logical circuits from the remote deployment (whether through co-location at the remote site, handoff of the ATM payload from the remote provider’s deployment, or some other method) and the amplification of CO based ADSL signals to raise the power level at the remote location to a level comparable to that of the remotely deployed ADSL signals. It is important to note that some of these techniques may be more scaleable than others.

- C. While we desire to migrate TU-C's closer to the customer, it is important to recognize the current investment in CO-based DSL equipment. This investment must be considered and weighed against the benefits of the more robust and higher speed service offerings enabled by TU-C migration when proposing possible resolutions to the spectral compatibility problems that may appear in the course of the migration.
- D. The foundations of spectrum management and wireline spectral integrity are based on the premise that the guidelines will reduce the occurrence of service degradation to a rate where these events can be remedied in a timely manner, without requiring the dedication of excessive resources to remedy the problems. Therefore our recommendations on intermediate TUs involve the application of both preventative measures and remedial "after the fact" measures, depending on the expected problem occurrence rate.

### **Recommendations:**

1. Focus Group 3 recommends that T1E1's continuing work on spectrum management standards embrace, as a whole, the background and recommendations contained herein.
2. As a preventative measure, the industry should be encouraged to employ available transmit power management mechanisms to minimize the effect of FEXT from remote deployments. One method that has been proposed to do this for ADSL modems is to limit the maximum noise margin per tone to the smallest value where data performance is not affected – this effectively results in tones with lower transmit power and/or fewer tones used. While this will undoubtedly reduce the amount of FEXT caused by remote ADSL, the benefits to be gained from this recommendation are under study.

Furthermore, we recommend that industry standards bodies incorporate and require implementation of appropriate transmit power management mechanisms in future DSL standards, and that T1E1 incorporate and encourage the use of transmit power management mechanisms in future spectrum compatibility standards.

NRIC V Focus Group 3  
Wireline Network Spectral Integrity  
Final Report and Recommendations

January 4, 2001

**Appendix 7**

**Recommendation # 7**  
**(Final version as revised and approved)**

**NRIC V FG3 Recommendation # 7:  
Exchange of spectrum management information between loop owners, service providers and equipment vendors**

I. Background:

In the interest of wireline spectrum management and spectral compatibility, the FCC issued its Line Sharing Order<sup>1</sup>, which required that certain information be shared between loop owners and those providing services on unbundled or shared copper loops<sup>2</sup>. When the Line Sharing Order was adopted, the requirements for information exchange (a product of the NPRM process) seemed complete, fast and fair. Since that time, implementation of these rules have proven them to be incomplete, slowing the deployment of DSL services and causing both loop owners and service providers to incur undue expense. The recommendations NRIC V FG3 propose herein provide foundational understandings, a streamlined approach to the sharing of spectrum management information and a process to be followed prior to escalating to interference dispute. As an alternative to the current rules and practices, NRIC V FG3 believes that these recommendations will benefit DSL consumers.

The copper loop plant was designed, and is maintained, to provide voice-grade services (POTS). The economics for DSL assume that DSL can be deployed on this loop plant as a by-product of it being so maintained. The American National Standard "Spectrum Management for loop transmission systems" T1.417-2001, is based on statistical modeling of the crosstalk coupling characteristics of this loop plant, and establishes limits on the power (and frequencies) which a DSL transceiver can inject on the loop. These power limits<sup>3</sup> have been established such that DSL service providers can determine their own service deployment guidelines with an expectation that the interference on the loop is below a specified level. As a result, interference disputes should be rare events.

NRIC V FG3 recognizes that all parties involved in the deployment of DSL equipment in the public network must adhere to spectrum management guidelines for the provisioning of DSL loops to be successful in providing the maximum benefit to end users. We believe it is in the best interest of the industry to require that each service provider take responsibility for ensuring that its equipment is deployed according to the aforementioned spectrum management guidelines.

---

<sup>1</sup> *Deployment of Wireline Services Offering Telecommunications Capability and Implementation of Local Competition Provisions of the Telecommunications Act of 1996*, Third Report and Order in CC Docket No. 98-147, Fourth Report and Order in CC Docket No. 96-98, 14 FCC Rcd 20912 (Released December 9, 1999) ("Line Sharing Order").

<sup>2</sup> See Line Sharing Order, paragraph 204.

<sup>3</sup> These power (or more accurately, Power Spectral Density) limits are not restricted to Power Spectral Density masks, they also include formula or calculation based criteria.

II. Recommendations:

***A. As a consequence of these NRIC V FG3 Recommendations, the exchange of spectrum management and spectral compatibility related information (other than EWL as specified in section II.B.2 of this recommendation) is not required at the time the loop is provisioned<sup>4</sup>. Previous FCC action in Paragraph 204 of the Line Sharing Order requiring initial disclosure of spectrum management information is no longer valid. NRIC V FG3 therefore recommends that rules 51.231 (a)(3), (b) and (c) be rescinded.***

***B. NRIC V FG3 recommends that the loop providers' spectrum management responsibilities shall be:***

1. Ensuring that the loop plant is maintained to an acceptable level to provide analog voice-grade service. Specific parameters are shown in Annex A.
2. Upon request, providing the service provider with loop information that can be used to derive Equivalent Working Length (EWL) such that the service provider may determine conformance to T1.417-2001<sup>5</sup>, and;
3. After all of the requirements have been met for escalating to an "interference dispute"(see section II.D. of this recommendation), identifying all service providers that it reasonably concludes might have an impact on the dispute as well as the circuit IDs and Connecting Facility Assignments of those services. This will allow the service providers to then start a process among themselves to resolve the conflict.

---

<sup>4</sup> However, service providers are encouraged to disclose whether or not the service being provisioned is compatible with known disturbers, so the loop provider knows to choose facilities that avoid known disturbers if possible.

<sup>5</sup> Several automated methods for obtaining such information may be available; one example is obtaining a loop makeup from a database (e.g. LFACS). NRIC V FG3 is currently considering another possibility, where EWL could be inferred from capacitive loop length measurements. In addition, future DSL transceivers may have the ability to infer EWL based on characteristics of the received signal. Where an automated method to obtain the information exists, it should be used in lieu of manual compilation. It is the expectation that future revisions of T1.417-2001 will more readily accommodate these automated measurements. To the extent that the providers of such information have not already done so, they shall be entitled to recovery of fair and reasonable costs to provide such information.

***C. To enable adherence to spectrum management guidelines, it will be necessary for DSL equipment vendors, loop providers and service providers to exchange spectral management information at times (as specified in this recommendation) other than provisioning. This information shall be provided in a timely manner when requested, and any charges for costs associated with providing this information shall be fair and reasonable. NRIC V FG3 recommends the following requirements regarding compliance and exchange of spectrum management information:***

1. Compliance to T1.417-2001: On a going forward basis, service providers shall deploy DSL equipment in a manner that complies with the requirements of the American National Standard, "Spectrum Management for Loop Transmission Systems" T1.417-2001. In the event of escalation to a spectral interference dispute, all involved service providers shall make relevant spectral management compliance information available to all parties involved in the dispute as follows:

**a) In cases where compliance is claimed using a SM Class, the specific SM Class information shall be provided.**

**b) In cases where compliance is claimed using technology specific guidelines, technology specific designations (e.g. TS xxx, per T1.417-2001) shall be provided.**

**c) In cases where the analytical Method in Annex A of T1.417-2001 has been used, the transmit PSD, analytical method calculations, and resulting maximum EWL of the specific technology shall be provided.**

**d) In all cases, EWL derivation(s) for the loop and all other data needed to demonstrate compliance to T1.417-2001 shall be provided.**

**e) In all cases, all service providers shall identify those systems not covered by the requirements of T1.417-2001 that they reasonably conclude might have an impact on the interference issue.**

**f) In all cases, all service providers should cooperate in an attempt to resolve all interference disputes in a timely manner.**

2. Spectral Compatibility Measurements and Calculations: The party, e.g., equipment vendor, responsible for verifying the spectral compliance of a particular service provider owned<sup>6</sup> DSL product for use in the public network shall ensure that the equipment conforms to the requirements of T1.417-2001. Appropriate laboratory measurements or calculations used to determine this conformance shall be kept on file by this party, and made available to those service providers deploying that equipment.

3. Equivalent Working Length Information: For many loop technologies, compliance to T1.417-2001 requires knowledge of the Equivalent Working Length (EWL). The service provider is responsible for estimating EWL, either from its own data or from data obtained per II.B.2. Service providers shall keep EWL information, and associated measurements or calculations, on file. Upon escalation to an interference dispute, this information shall be made available as necessary to parties in the dispute.

---

<sup>6</sup> Spectral Compliance of end-user owned TU-R products must be covered under a future version of ANSI/TIA-968 or similar ACTA approved document for prevention of harms to the network.

***D. There should be universal recognition that the DSL industry is best served if the incidence of 'Interference Dispute' is extremely rare. It should also be recognized that there will always be loops that qualify for DSL that will not support DSL. As a baseline, loops that are maintained to an acceptable level to provide analog voice-grade services are deemed acceptable. In fact, the experience of those in Focus Group 3 is that most conditions resulting in DSL 'troubles' will be detected as POTS 'trouble.' NRIC V FG3 recommends that escalation into 'Interference Dispute' will require the complainant service provider to first do the following:***

1. Investigate if any additional customer equipment has been added to line;
2. Verify proper DSLAM and CPE operation;
3. Ensure that the service providers own internal deployment rules have been followed;
4. Ensure that the service degradation is not due to network congestion or a transport network fault.
5. Verify that the loop can provide analog voice-grade service, per the requirements shown in Annex A ;
6. Verify that the DSL service is deployed in compliance with T1.417-2001;
7. Make a wideband noise measurement to determine if an unacceptable level of interference exists.



### III. Additional Considerations

1. The actual resolution of interference disputes is beyond the scope of this recommendation. Conditioning or rearrangement of loops (to resolve interference disputes) continues to be the subject of interconnection agreements or other regulations which should be considered unaltered by the contents of this recommendation.
2. It should be noted that the exchange of information other than the spectrum management and spectral compatibility related information specifically addressed by this recommendation is beyond its scope. Such information exchanges, especially with regard to provisioning, are the subject of interconnection agreements and should be considered unaltered by the contents of this recommendation.
3. The reader is encouraged to ensure that there is not confusion between an “interference dispute” and “repair”. “Interference dispute” denotes that service providers are convening to jointly resolve an interference problem. “Repair” denotes that a loop provider is working to correct a loop that did, but now does not, meet the analog voice-grade service parameters<sup>5</sup>. Therefore, the time during which a complainant service provider is performing the duties enumerated in Part D of these recommendations as well as time spent in “interference dispute” among service providers should not be counted towards a loop provider’s MTTR metrics.
4. Work has been done in the industry to create many NC/NCI codes for service ordering. These codes have been created with the rules of 51.231 (a)(3), (b) and (c) in mind and therefore are associated with specific spectrum management information, often including technology type, SM Class or PSD mask. In order to be consistent with the NRIC V FG3 recommendations contained herein, NC/NCI codes containing spectrum management information should not be used on a going-forward basis. Efforts to address this discontinuity are the subject of liaison work between the NC/NCI Tag and NRIC V FG3. The NC/NCI Tag is Co - chaired by Bob Mierzejwski (732) 699-5420 and Rick Gonzalez (732) 699-5842.
5. The contents of this recommendation refer to and are based on T1.417-2001 as published. This recommendation, and any items implementing its content, should be reviewed upon publication of any future editions of T1.417 to ensure the relevance of this reference. If the NRIC VI charter includes a group similar (to NRIC V Focus Group 3) in mission and scope, that should be the body to review and if necessary revise, and seek approval of, such revisions.

IV. Annex A - Pass/Fail Criteria for Metallic Loops

NRIC V Focus Group 3 wishes to acknowledge and thank T1E1.3 for providing this information.

**Table 1 - Pass/Fail Criteria for Metallic Loops**

<b>Test Type</b>	<b>Loop Parameter</b>	<b>Pass/Fail Criteria</b>
End-to-End	LS/GS dc Loop Current	Greater than or equal to 20 mA
	Or dc Loop Resistance (Note 1)	Less than or equal to 1300 ohms (Note 2)
	C-Message Metallic Noise	Less than or equal to 30 dBmC
	1004 Hz Transducer Loss	Less than or equal to 10.5 dB (Note 2)
Single-Ended	dc Insulation Resistance	Greater than or equal to 100k ohms T-G, R-G, or T-R
	Foreign dc Voltage	Less than or equal to 6 Vdc T-G, R-G, or T-R with 100k ohm voltmeter
	Foreign Longitudinal ac Voltage	Less than or equal to 25 Vrms T-G or R-G With 100k ohm voltmeter
	Capacitive Balance T-G and R-G	Greater than or equal to 95%

- 1- The dc Loop Current test is applicable to loops that are used in connection with loop-start or ground-start voice service as in the case of Line Sharing. The dc Loop Resistance test is applicable to all other loops.

- 2- The dc Loop Resistance and 1004 Hz Transducer Loss criteria are based on Non-Loaded Resistance Design guidelines. If a loop was originally designed using other design guidelines such as Unigauge Design, Loaded Resistance Design, or Long Route Design and the load coils were removed to support an advanced service, then the values shown in the table for the dc Loop Resistance and 1004 Hz Transducer Loss criteria would not be applicable.

### Description of End-to-End Tests<sup>7</sup>

1- dc Loop Current or dc Loop Resistance. Loop current is measured when the loop is used with a loop-start or ground-start voice service. Loop resistance is measured for all other applications.

Loop current is measured with a 430-ohm load substituted for the CI at the NI. The requirement is 20 mA or more (i.e., 8.6 Vdc across the 430-ohm resistor).

Loop resistance is measured with an ohmmeter connected between the tip and ring conductors at one end of the metallic pair with the tip and ring conductors at the far end of the metallic pair shorted. The requirement depends on the loop design:

(a) Non-loaded metallic pairs designed to resistance design guidelines should have a dc loop resistance of 1300 ohms or less.

(b) Metallic pairs originally designed with load coils but no range extension with gain should have a dc loop resistance of 1500 ohms or less.

(c) Metallic pairs originally designed with load coils and range extension with gain should have a dc loop resistance of 3600 ohms or less.

2- C-Message Metallic Noise.<sup>8</sup> Voiceband metallic noise is measured per IEEE 743-1995 with a noise measuring set at the NI having an input impedance of 600 ohms resistive and a 900 ohms resistive termination at the CO. The metallic noise requirement is 30 dBmC or less.

3- 1004 Hz Transducer Loss. Transducer loss<sup>9</sup> is defined as  $-10 \log P_L/P_{AS}$ , where  $P_L$  is the power delivered to the load, and  $P_{AS}$  is the maximum power that is available from the source. Specifications for the measurement of transducer loss are defined in IEEE 743-1995. For this test, the impedance at the CO end of the loop shall be a 900 ohms resistive and the impedance at the NI shall be a 600 ohms resistive. The transmitted signal power shall be greater than -20 dBm but less than or equal to 0 dBm. The 1004 Hz transducer loss shall not exceed 10.5 dB for metallic pairs that were originally designed to conform to non-loaded Resistance Design guidelines.

---

<sup>7</sup> End-to-end tests are measurements at the Network Interface (NI) that are made with the indicated condition or termination at the CO end of the loop.

<sup>8</sup> The C-Message metallic noise test measures the unwanted metallic signals resulting from internal and external interference. An example of an internal noise source is thermal noise. Examples of external noise sources are power line induction and crosstalk.

<sup>9</sup> Transducer loss is not the same as insertion loss.

## Description of Single-Ended Tests<sup>10</sup>

1- Insulation Resistance. Insulation resistance is the dc resistance between (1) the tip conductor and ground, (2) the ring conductor and ground, and (3) the tip and ring conductors. The requirement is a dc resistance of 100k ohms or more Tip-to-Ring, Tip-to-Ground, and Ring-to-Ground.

2- Foreign dc Voltage.<sup>11</sup> Foreign dc voltage is measured between (1) the tip conductor and ground, (2) the ring conductor and ground, and (3) the tip and ring conductors with the far-end open using a voltmeter that has an internal resistance of 100k ohms.<sup>12</sup> The foreign dc voltage requirement is 6 Vdc or less.

3- Foreign Longitudinal ac Voltage. This test measures the magnitude of ac voltage that has been coupled to the pair from commercial power lines. Foreign ac voltage is measured at the CO with the far end open using a voltmeter having an internal impedance of 100k ohms. The requirement is 25 Vrms or less tip to ground, and ring to ground.<sup>13</sup>

4- Capacitive balance. This test compares the capacitance to ground of each conductor with the far end open. Capacitive balance is expressed as the percentage that results when the larger capacitance value is placed in the denominator and the smaller capacitance value is placed in the numerator. The requirement is 95% or greater.

---

<sup>10</sup> Single-ended tests are measurements made from the CO with the far-end (i.e. the NI) open. If an open termination is not provided at the NI, measurement results may be affected by customer premises equipment and wiring.

<sup>11</sup> The foreign dc voltage test measures the magnitude of the dc voltage coupled to the tip and ring conductors from external sources (e.g., CO battery).

<sup>12</sup> The use of a higher impedance voltmeter will result in significantly higher values of foreign voltage than would be measured with a voltmeter impedance of 100k ohms.

<sup>13</sup> There is no single-ended test for ac voltage between the Tip and Ring conductors. Foreign ac Tip-to-Ring voltages are manifested in the C-Message Metallic Noise test.

NRIC V Focus Group 3  
Wireline Network Spectral Integrity  
Final Report and Recommendations

January 4, 2001

**Appendix 8**

**White Paper**

**(Final version for publication)**

## **Remote Deployments of DSL: Advantages, Challenges, and Solutions**

*A publication of the Network Reliability and Interoperability Council (NRIC)*

December 14, 2001

## *Remote Deployments of DSL: Advantages, Challenges, and Solutions*

The following members of NRIC-V, Focus Group 3 dedicated their time and talent to the development of this white paper:

Edward Eckert, Catena Networks, Chairman Focus Group 3

Philip Kyees, Paradyne, Chairman FG3 SC1

Massimo Sorbara, GlobeSpan, Chairman FG3 SC2

Brad Beard, AT&T

Jamal Boudhaouia, Qwest

Jim Carlo, Texas Instruments

Paul Donaldson, WorldCom

Gene Edmon, SBC

Thomas Maudoux, Texas Instruments

Harry Mildonian, Lucent Technologies

David Reilly, Rhythms

David Rosenstein, Covad Communications

Kevin Schneider, ADTRAN

Greg Sherrill, Verizon

Patrick Stanley, Elastic Networks

Gary Tennyson, BellSouth

John Unruh, Lucent Technologies

Pete Youngberg, Sprint

The members of FG3 owe special thanks to the following members of the FCC staff for their assistance in the execution of FG3's tasks:

Young Carlson, FCC OET

Aaron Goldberger, FCC CCB

Kent Nilsson, FCC OET

Paul Marrangoni, FCC OET

Jessica Rosenworcel, FCC CCB

Elizabeth Yockus, FCC CCB

**ABSTRACT**

This paper addresses the wireline network spectral integrity challenge created when DSL transceivers are deployed at locations remote from the central office (CO) yet within the potential reach of CO-based DSL transceivers.<sup>1</sup> It discusses background, technologies, architectures and major issues surrounding the evolution of the telecommunications access network as they relate to remotely deployed DSL transceivers and wireline network spectral integrity.

The paper aims to assist the FCC and the industry in managing this very complex and difficult problem by promulgating a consistent understanding of the underlying issues. It offers options for possible solutions for deployment of CO-based systems in the presence of remote DSL transceivers. This paper does not address repeatered systems.

All of the members of NRIC-V Focus Group 3 agreed to the inclusion of all of the material in this paper. There is no consensus, however, on the extent to which any of the benefits, challenges or possible solutions will affect the industry's ability to provide the consumer with more advanced service choices (type and supplier) while maintaining wireline spectral integrity in a competitive, cost-effective, and business-driven manner.

---

<sup>1</sup> This problem has the potential to take on different forms as DSL transceivers are placed between RTs and the end user (e.g. FTTx, ONU or MTU architectures).



# *Remote Deployments of DSL: Advantages, Challenges, and Solutions*

## **1. Introduction**

### ***1.1. Purpose and Scope***

The purpose of this paper is to provide the FCC and the telecommunications industry a compendium of the background, technologies, architectures and major issues surrounding access network evolution as it affects, and is affected by, wireline network spectral integrity.

The white paper approach was taken due to lack of consensus in NRIC-V Focus Group 3 on a single solution to the problem created when DSL transceivers are deployed at locations remote from the central office (CO) yet within the potential reach of CO-based DSL transceivers.<sup>2</sup>

It was agreed that the facts surrounding this problem could be included in such a paper, along with many points of view (possibly conflicting) on options for possible solutions to the deployment of remote DSL transceivers. Such an approach would assist the FCC and the industry in managing this very complex and difficult problem by promulgating a consistent understanding of it.

This paper does not address repeatered systems.

### ***1.2. The Big Picture***

There is a fundamental conflict between two equally important, but opposing, interests: (1) exploiting the business opportunity of migrating DSL transceivers closer to the customer, and (2) protecting the viability of services provided by DSL transceivers located at the central office.

Deployment of remote DSL transceivers provides a service benefit to consumers and a business opportunity to service providers. When deploying from a remote location, a larger percentage of the residential customer base can be served by reaching customers that cannot be easily served directly from the CO and higher data rates can be provided to customers for richer and more advanced services. The record shows many FCC staff entries embracing widespread broadband availability as being in the public interest.

While it is desirable to migrate DSL transceivers closer to the customer, there exists a potential threat to competition by doing so. When proposing possible resolutions to potential spectral compatibility problems, the current investment in CO-based DSL equipment must be considered and weighed against the benefits of the more robust and higher speed service offerings enabled by DSL transceiver migration.

When crosstalk from remotely deployed DSL transceivers is encountered, CO-based DSL transceivers may exhibit significantly reduced performance or be rendered completely inoperable. This crosstalk may be seen when customers, whose loops are in the same distribution cable, are served both from CO-based and remotely deployed DSL transceivers. The rate of occurrence of this condition is not yet fully known. Data from one region suggest that the rate of occurrence will be less than 7%. Some are concerned that the rate of occurrence could be significant since the particular architecture used and the deployment plans going forward will have an impact on the rate of occurrence; specific data to support this view may become available as the network evolves.

---

<sup>2</sup> This problem has the potential to take on different forms as DSL transceivers are placed between RTs and the end user (e.g. FTTx, ONU or MTU architectures).

## Remote Deployments of DSL: Advantages, Challenges, and Solutions

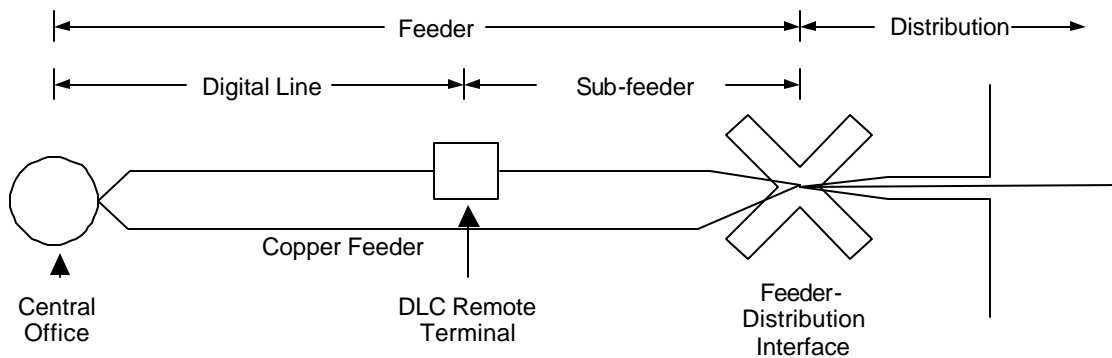
The foundations of wireline network spectral integrity are based on the premise that complete spectrum management guidelines, when properly implemented, will reduce the occurrence of service degradations to levels where such events can be remedied in a timely manner without requiring the dedication of excessive resources to remedy the problems. As of the date of this paper standards for spectral integrity [1] assume network-side transceivers collocated in the central office; they do not include any additional requirements associated with remote transceivers deployed to the same customer distribution area. Currently, an issue 2 of the spectrum management standard is being developed that will address remote deployment of network-side transceivers.

In summary, there is consumer value in CO-based DSL transceiver deployment as well as in migrating DSL transceivers closer to the customer. In order for both to succeed, a framework must be established to provide the consumer with more advanced service choices (type and supplier) while maintaining wireline spectral integrity in a competitive, cost-effective, business-driven manner.

### 2. Access Architecture and Remote DSL Transceivers

Historically, the predominant access architecture involved the use of paired metallic cables. Starting in the 1970's, loop carrier systems began to be deployed. These systems multiplex many customer services onto a small number of transport lines. In the 1980's these carrier systems started employing digital technology, and are denoted Digital Loop Carrier (DLC) systems. Please see Annex A for more details on both DLC and metallic cable design practices and Annex B for loop architecture models.

In some cases, all of the circuits in an area are 'cut-over' to the DLC. There is no metallic path, of whatever length, available to directly connect a potential user to the CO. In other instances, the DLC transport parallels existing copper feeder cable. In these cases, a Feeder Distribution Interface (FDI, sometimes referred to as a Serving Area Interface (SAI)) provides for connection to either the copper feeder cable or the feeder circuits provided via DLC. This arrangement allows the service provider to provide service to the customer via the copper plant or via the DLC remote terminal. Figure 1 portrays this arrangement. Note that the FDI and the DLC remote terminal are often co-located.



**Figure 1:** Dual Loop Architecture Reference Diagram

The above architecture — involving both DLC and copper feeding the same FDI — permits DSL to be deployed from the RT (remote DSL) or, if the copper feeder is short enough, from the central office. Due to the difference in signal level between the two DSL transceivers, spectral compatibility issues may arise when remote DSL is used to serve areas that can also be served via the copper feeder. This problem is

## *Remote Deployments of DSL: Advantages, Challenges, and Solutions*

accentuated on longer loops when remote DSL transceivers are placed closer to the customer. This can be the case when a remote DSL transceiver is placed in a Multi-Tenant Unit or in a curbside pedestal.

This Spectral Compatibility Issue will be defined further in Section 5.

### **3. Benefits of Deploying Remote DSL Transceivers**

#### **3.1. Loop Limitations**

It is well understood that many customers cannot obtain Digital Subscriber Line (DSL) service. Assuming that a DSL service provider is offering service from the Central Office (CO) from which the potential DSL customer would be served, the reason that DSL is not available is in fact due to local loop limitations. These limitations include the following:

- DLC deployments that preclude direct metallic access to the CO.
- The use of load coils, i.e., inductors spliced in series at periodic intervals on the loop in order to maintain acceptable voice-grade quality.
- The loop over which the potential customer is served, although not loaded, is judged by the potential service provider to be so long that there is a significant likelihood that the DSL circuit will not operate successfully.

Each of these is explored in more detail below.

##### **3.1.1. Digital Loop Carrier**

DLC technology is often used to provide feeder facilities to an area. In some cases, all of the circuits in an area are 'cut-over' to the DLC. There is no direct metallic path available to connect the potential DSL customer to the CO. In this case, a remote DSL transceiver is the only means of providing the service.

In other cases, DLC technology is used to supplement the existing metallic feeder pairs. In these cases, some or all of the existing metallic feeder pairs are left available, but 'growth' is served via the DLC-provided feeder. In many of these cases, the area served is so far from the CO that DSL cannot be supported on the metallic paired cable. Again, in such a case, deployment of a remote DSL transceiver is the only means of providing the service.

##### **3.1.2. Loading**

Annex A provides a definition of loading. Most DSL systems cannot operate over loaded loops. Note that loading coils generally exist only in the feeder portion of the loop. Where loops are short enough such that loading is not required to ensure adequate voice grade performance, the load coils may be removed to enable DSL service. Otherwise, a remote DSL transceiver connected to the FDI (hence, beyond the last loading coil) is generally the only means of providing the service.

##### **3.1.3. Long, Non-Loaded Loops**

Successful DSL transmission, like any digital transmission scheme, requires that the DSL 'receiver' enjoy some minimum Signal-to-Noise Ratio (SNR). This metric consists of two components, i.e., the received signal level, and the noise level. As the loop gets longer, the received signal level drops. The received noise is assumed to be due to crosstalk from systems on other cable pairs. The pair-to-pair coupling

## ***Remote Deployments of DSL: Advantages, Challenges, and Solutions***

provided by the crosstalk, though, is non-deterministic, i.e., some pair-combinations provide for greater coupling than do other combinations.

Given that the noise coupled via crosstalk is an unknown, it can be seen that, as a loop gets longer, the probability that a specific DSL system will enjoy some minimum SNR (and thus be capable of providing an acceptable grade of service) diminishes. This factor, coupled with the variables in the wiring in a customer's premises and the desire to maximize the ratio of successful installations, has resulted in a decision by some service providers to 'disqualify' longer non-loaded loops.

Again, in such a case, deployment of a remote DSL transceiver is generally the only means of providing the service.<sup>3</sup>

### ***3.2. Greater Data Rates***

In addition to providing DSL service to those customers that could otherwise not obtain service, remote DSL platforms provide a means to evolve broadband capabilities. Although DSL service might be available, for instance, to a customer on a loop consisting of 14 kft of 26 AWG (American Wire Gauge) cable, the resultant data rate may not prove to be satisfactory as the broadband access market matures. While a customer might initially be satisfied with something less than 1 million bits per second (Mbps), that data rate might not be satisfactory in a few years.

Because remote DSL transceivers are located at a point much closer to the customer (than from the CO) the DSL service from the remote platform can be arranged to operate at a significantly greater data rate, relative to that data rate that could be achieved from the CO. The data rate could be achieved through exploiting the entire capacity of the mature Asymmetric Digital Subscriber Line (ADSL) technology, or through the use of an evolving technology, such as Very-high-bit-rate Digital Subscriber Line (VDSL).

### ***3.3. Summary of Remote DSL Advantages***

In summary, remote DSL platforms provide the following two benefits:

- DSL service to those customers who could not otherwise obtain the service, and
- Higher data rates, relative to the data rate that could have been obtained via metallic paired cable from the CO.

## **4. Challenges of Deploying Remote DSL Transceivers**

The environment into which remote DSL transceivers are deployed presents several unique challenges to service providers, including the following:

- Space – Remote cabinets and enclosures have space limitations that are not generally encountered in Central Offices.

---

<sup>3</sup> Some proprietary DSL implementations may provide for greater loop reach in this case than does standards-based ADSL. However, such implementations may not provide the data rate afforded by a remote DSL transceiver, or meet other service provider requirements.

## *Remote Deployments of DSL: Advantages, Challenges, and Solutions*

- Variety of services – Because remote locations do not have the size and scalability of Central Office locations, the variety of DSL services that can be economically offered by multiple service providers is limited.
- Backhaul of data – In some cases, there is insufficient data capacity between the CO and the RT to adequately serve remote DSL deployments.
- Power – Remote locations are less likely to have excess reserve dc powering and battery backup than Central Office locations.
- Craft access – Unlike Central Office equipment, Remote equipment is generally not in open racks that can be easily accessed.
- Environmental requirements – Remote locations often require the use of environmental vaults or temperature hardened equipment that is not needed for Central Office deployments.
- Economics – The smaller number of customers typically served by a remote location (as compared to a CO) presents a challenge to the service provider's business case.
- Competitive access – Collocation space is generally less abundant in remote locations than in CO locations.
- Voice switch access – It may be difficult to wire DSL equipment to voice switches and splitters in a remote environment.
- Competitor's ease of connectivity - Cross-connection access to the incumbent's facilities may not be readily available to competitors in a remote environment.

Another significant challenge to deployment of remote DSL transceivers is maintaining spectral compatibility between the remote DSL and CO-based DSL. This spectral compatibility challenge is discussed in detail in Section 5.

### **5. Wireline Network Spectral Integrity Issues**

While there are advantages of delivering DSL service via remote platforms, there are some instances where the remote DSL can cause significant interference into DSL being served from the CO. The problem will primarily be seen when remote and central office deployments of ADSL serve customers using the same distribution cable and the total loop length from the CO to the customer premises is short enough (e.g. 15.5 kft EWL, or Equivalent Working Length, according to T1.417-2001[1]) to support the affected DSL (namely ADSL).

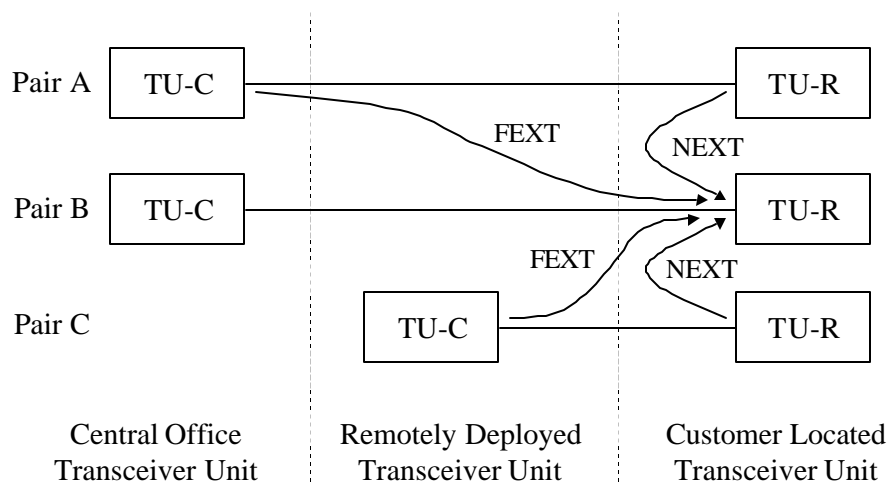
For many remote DSL deployments, either because of the distance of the deployment from the CO or because there are no copper facilities between the CO and the customer, this interference is not an issue. In addition, when all of the service providers' DSL transceivers are deployed at the same remote location, the existing spectrum compatibility requirements and assumptions from T1.417-2001 [1] apply.<sup>4</sup> However, there are currently no standards (i.e. Committee T1/T1E1.4) or regulations, which prevent deployments where interference could be a significant problem. Given that remote deployments of DSL are ongoing, it is important that the issues are understood and appropriate action taken. This section provides a technical background of the issues involved.

---

<sup>4</sup> This was proposed in T1E1.4/2001-060 [2] and agreed in T1E1.4 as new text for the next issue of T1.417-2001 [1].

**5.1. Crosstalk and DSL performance**

Figure 2 shows a DSL deployment with multiple pairs in a single binder group. Two of the pairs, A and B, run from the CO DSL transceiver to the customer located DSL transceiver while the third pair, C, runs from a remotely deployed DSL transceiver to the customer located DSL transceiver.



**Figure 2:** Model of remotely deployed transceiver units in a multi-pair cable.

The quality of the signal at the receiver limits the performance of DSL systems. Both the absolute strength of the signal at the receiver, and the strength of the desired signal relative to the noise seen at the receiver are critical to reception. The cable length and attenuation, along with the transmitter power, largely determine the strength of the signal at the receiver. When multiple DSLs coexist in the same binder group, crosstalk between pairs in the binder is a major source of noise, and a major limiter of performance.

Crosstalk caused when the signal transmitted from the (CO and/or remotely deployed) TU-C of one pair appears at the far end of another pair is called Far End crosstalk (FEXT). In Figure 2, the crosstalk caused by the TU-C transmitters of pair A and pair C create noise which limits the ability of the customer located TU-R receiver at the end of pair B to detect the signal intended for it.

Similarly, crosstalk caused when the signal transmitted from the (customer located) TU-R of one pair appears at the near end of another pair is called Near End crosstalk (NEXT). In Figure 2, the crosstalk caused by the TU-R transmitters of pair A and pair C create noise which limits the ability of the customer located TU-R receiver at the end of pair B to detect the signal intended for it. NEXT can also occur between TU-C's, for example between the TU-C's of pairs A and B in Figure 2.

DSL systems can be classified as frequency division duplex (FDD), echo cancelled (EC), and hybrid. FDD DSL systems use different frequency bands for upstream (TU-R to TU-C) and downstream (TU-C to TU-R) traffic. Echo cancelled systems use the same upstream and downstream frequency bands and have echo cancellers to eliminate interference from the echo generated at the far end of the pair. Hybrid systems have partially overlapping frequency bands in the upstream and downstream directions.

## *Remote Deployments of DSL: Advantages, Challenges, and Solutions*

Frequency division duplex system performance is typically limited by FEXT, while echo cancelled system performance is typically limited by NEXT.

### **5.2. *Effect of DSL Transceiver Location***

The effect of NEXT and FEXT on ultimate performance depends on the construction of the cable, the relative location of the DSL transceivers, and on the type of DSL. Cable design can change both the attenuation and the inter-pair coupling. As coupling between pairs increases, so does the crosstalk experienced at the receiver. In Figure 2, the downstream DSL transmitter for pair C is much closer to the receiver for pair B than the downstream transmitter for pair B. The cable for pair B attenuates the signal from the Central Office located DSL transmitter to the customer located DSL receiver much more than the cable for pair C attenuates the signal from the remotely deployed DSL transmitter to the customer located DSL receiver. Subscriber C may have better performance than subscriber B because of the reduced attenuation and resulting stronger signal. Unfortunately, the crosstalk induced in pair B by the downstream transmitter for pair C has similarly reduced attenuation. More FEXT is detected at the receiver on pair B from pair C than is detected at the receiver on pair B from pair A. In some deployments, the FEXT from pair C detected at the receiver from pair B may be nearly as strong as the desired signal from the transmitter at the far end of pair B. In this case, the customer on pair B experiences service that may have significantly reduced performance or may be rendered completely inoperable.

### **5.3. *The CO-RT crosstalk model***

When customers served from remotely deployed DSL transceivers (hereafter simply referred to as RTs) using the same distribution cable as customers served from the Central Office (CO), the crosstalk models<sup>5</sup> are different than when all DSL transceivers are collocated. Compared to the case where all service providers' DSL transceivers are deployed from the same location, the DSL transceivers at the customer sites experience greater far-end crosstalk (FEXT) from the remote DSL transceivers than from the CO-based DSL transceivers. See Annex C for a more complete description of FEXT and near-end crosstalk (NEXT). Increased FEXT may occur when customers whose loops are in the same distribution cable are served both from CO-based and remote DSL deployments.

### **5.4. *Influence of DSL technology specific characteristics***

The effect of the RT crosstalk coupling is quite different depending on the spectral properties of the DSL technologies that are involved. The increased FEXT coupling from the RT-based signals can significantly reduce the level of performance (either in data rate capacity or bit error ratio) in the downstream (CO-to-customer) direction for systems that are designed to have their performance limited by the level of FEXT that is present. ADSL and VDSL are deployed as self-FEXT limited systems because they use different transmit frequencies in each direction, a technique known as frequency division duplexing. As a result, CO-based DSL transceivers may exhibit significantly reduced performance or be rendered completely inoperable when significant FEXT coupling from RT-based ADSL systems is present. This reduced

---

<sup>5</sup> A model showing the crosstalk coupling functions of interest is included in Annex L of T1.417-2001[1]. This model assumes that the pairs from the CO and RT share a binder group the entire distance from the RT to the customer. This assumption is a bit pessimistic. As shown in LA#5 of Figure 3 in Annex B (and in Figure 1 of Section 2), the FEXT from the RT-based TU-C is attenuated by the loss of the sub-feeder. The new model, which does include the effects of the sub-feeder, is shown in Annex C.

## *Remote Deployments of DSL: Advantages, Challenges, and Solutions*

performance has been documented in several T1E1.4 contributions, including T1E1.4/2000-302 [7] and T1E1.4/2000-336 [8].

Relatively unaffected by the increased FEXT coupling from remotely deployed DSL transceivers are full-duplex DSL systems that use identical transmit spectra from both the service providers' and customers DSL transceivers; it is self-NEXT that limits the performance of these systems.<sup>6</sup> Because the performance of these systems is limited by self-NEXT, the increased level of FEXT only slightly reduces their performance. The NEXT coupling is still stronger than the increased FEXT coupling for most loop lengths). This has been documented in T1E1.4/2000-240 [11] and T1E1.4/2001-081 [12].

Affected to a greater degree than classical self-NEXT limited systems, but still less than ADSL, are the full-duplex DSL systems, which use transmit spectra that are different in each direction but overlapped in frequency.<sup>7</sup> Remote deployment of these systems also affects the performance of CO-based ADSL more than the classical self-NEXT limited systems.

Documentation of the effect that RT-based ADSL has on HDSL2 has been provided in T1E1.4/2001-081 [12].

### **5.5. *Influence of loop plant design (or architecture) on expected rate of incidence***

The expected rate of occurrence of CO and RT-based xDSL sharing the same distribution cables is dependent on loop architecture. Since the affected distribution area must be served from both the remote location and the CO, the problem is more likely to be seen where the remote platform has been added to reinforce the loop plant originally served from the CO.

Several T1E1.4 contributions have addressed the issue of how likely this is to occur. In T1E1.4/2001-069 [13] and in contributions to NRIC-V FG3, BellSouth reported that in their loop plant, less than 7% of the loops working through a Feeder-Distribution Interface (FDI) and within 15 kft of the CO are served via DLC. For this particular loop plant, this number represents an upper bound on the percent of loops that have the potential to see this problem. T1E1.4/2001-179 [15] provides a similar analysis, using data from a 1990 survey of 126 wire centers in five regions (T1E1.4/2001-132)[14], finding 12 to 18% of loops eligible for remote DSL deployments are within 15.5 kft, and thus candidates for the crosstalk problem. When presented, several expressed concern that, since the data was 10 years old, quite a small sample, and did not include the impact of recent DSL deployments such as SBC's "Project Pronto", the analysis was not necessarily reflective of the current loop plant. These studies may not necessarily represent the impact of all future loop plant deployment architectures. For example, VDSL (which is very likely to be deployed from a remote location) has not been considered.

## **6. Possible Solutions to the Spectrum Compatibility Challenge of Remote DSL**

In the previous sections, we detailed the problem created when DSL transceivers are deployed at locations remote from the central office (CO) yet within the potential reach of CO-based DSL transceivers. In this section, we discuss possible solutions to this problem.

---

<sup>6</sup> Examples of such systems include Basic Rate ISDN, IDSL (T1.601 [3]), HDSL (G.991.1 [4]), SDSL, and the versions of SHDSL with symmetric spectra (G.991.2 [5], T1.422 [6]).

<sup>7</sup> Examples of such systems include HDSL2 (T1.418 [9]), HDSL4 (T1.418 issue 2 [10]) and the versions of SHDSL with asymmetric spectra (G.991.2 [5], T1.422 [6]).



## *Remote Deployments of DSL: Advantages, Challenges, and Solutions*

Within NRIC-V FG3 there was unanimous agreement that where spectral compatibility problems occur due to the presence of remotely deployed DSL transceivers, a resolution to the problem needs to be available. However, there was disagreement on whether these solutions would be employed as a reaction to reported problems (reactive), or whether, as in the guidelines of T1.417-2001 [1], these solutions would be employed in a proactive manner, with the intent to keep spectral compatibility problems to a minimum. In this context, we define the following:

- Proactive means taking steps to assure that agreed-to analytical performance targets, such as those in T1.417, can be met by a CO-based DSL Service Provider such that the CO-based service provider's circuit is unlikely to become impaired by crosstalk originating from the remote DSL transceiver.
- Reactive means taking steps to mitigate the effects of crosstalk from the remote DSL platform, after these effects have resulted in degradation below the agreed-to performance targets of the CO-based DSL circuit.

Note that both proactive and reactive approaches could be applied on an "as needed" basis.

There was also no consensus on which party should be responsible for implementing solutions in either case.

Because of the wide variety of loop architectures and their impact on the spectrum compatibility problem, NRIC-V FG3 was unable to reach consensus on a one-size-fits-all solution. This section outlines pros and cons of the potential technical solutions that were discussed within the group.

Note that the solutions described below should not be considered an exhaustive list; other solutions may be possible.

### **6.1. Technical Solutions using PSD-Based Approaches**

The spectrum compatibility problem we have been discussing is caused by the presence of greater FEXT from the remotely deployed DSL transceiver than the FEXT-limited CO-based DSL transceiver was expecting. Because the characteristics of the cable cannot be changed, a solution to this problem involves adjusting the power and/or power spectral density of the DSL transceivers in such a way so that the power of the signals at the RT are all approximately the same. This can be done with one of two basic approaches (also referred to as categories):

- (a) Set the power of all signals at the RT (or equivalent points in the feeder) at standard transmit-levels. This can involve amplifying CO-based signals and/or moving the appearance of all ADSL<sup>8</sup> transceivers to the RT via RT collocation or derived logical circuits. This approach is applicable in either a reactive or proactive manner.
- (b) Lower or Alter the PSD of RT based systems so that they do not adversely affect CO-based ADSL systems. While this approach may be used in both reactive and proactive approaches, the reactive approach is most likely.

---

<sup>8</sup> ADSL is commonly referred to in this context, since it is a well-known and understood FEXT-limited DSL transceiver technology. Other FEXT-limited DSL transceiver technologies, including, but not limited to, VDSL, would be treated in a manner similar to ADSL.

## *Remote Deployments of DSL: Advantages, Challenges, and Solutions*

### **6.1.1. Discussion on category (a)**

Solutions that fall into category (a) either involve competitive access at the RT site or some sort of amplification of the CO-based ADSL signals at or near the RT so that the signal is of the same strength as the RT-based ADSL. Possible solutions to competitive access at RT sites include the following:

- Traditional physical collocation: This typically involves using the loop providers' existing remote enclosure to house the remote DSL Transceiver equipment of multiple service providers. This solution is in use today.
- Separate cabinets or enclosures: Such separate cabinets or enclosures would be located at or very near the existing remote site and would house the DSL Transceivers of additional and subsequent service providers. This solution is in widespread use today.
- Unbundled virtual circuit: This typically involves sharing the physical DSL Transceiver ports (deployed by the loop provider at the remote location) among multiple service providers thus offering all service providers a virtual path between the customer and a convenient point of presence. This solution is in use today.
- "Open backplane" with line card collocation: While included here for completeness, such solutions have found little support due to the operational complexities as well as the long and costly equipment development required to gain the proper economies of scale in future deployments. This solution is not in use today.

In general, amplifiers introduce additional spectrum management concerns. However, for the particular case of resolving spectrum management issues at the RT, amplifiers may be attractive. Amplifiers provide the RT-deploying service provider a way to "fix" any affected CO-based ADSL circuits, without getting involved in the actual modem signal processing, and the associated interoperability difficulties. There is a concern that such a solution is not scaleable. Difficulties related to this solution include finding a suitable location for the amplifiers and providing power to this location, which in many cases is not located at the RT-site, but rather at an equivalent spot on the CO-FDI feeder route. (See Annex B, Figure 3, loop architecture LA#5).

The solutions in this category provide an opportunity for RT-deploying service providers to accommodate the affected CO-based circuits of other service providers, without affecting the performance of their own deployments. Much of the discussion concerning these solutions revolved around who would pay for the solution and whether it would have to be provided for only existing affected ADSL circuits, or future CO-deployments as well (i.e. circuits that might be turned up in the future using equipment already deployed, or even new deployments of equipment in the COs). This last item was a subject of much disagreement and was the downfall of a proposed agreement.

There was also discussion concerning a different idea that has been adopted by the Australian network. The idea here is that spectral compatibility for all DSL deployments would be determined from a defined "deployment reference point" (DRP). In Australia, the DRP could be at any feasible interconnection point along the loop. It is believed that when a service provider desires to deploy DSL at an intermediate interconnection point (e.g. at a RT site), some form of policy exists which enacts a defined set of procedures to move the DRP to that remote deployment closest to the customer. Once a deployment has been made at an RT site, FEXT-limited systems deployed from "upstream" locations are deployed at their own risk; all attempts at being spectrally compatible with them are ended. Concerns about this approach include:

## *Remote Deployments of DSL: Advantages, Challenges, and Solutions*

- How service providers would be notified about the change in DRP,
- Whether service providers would have input into the decision to change the DRP,
- How much time service providers would have to modify their deployments to operate in the new environment,
- How effectively competitors could deploy in progressively smaller service areas as the DRP moves closer to the customer, and
- Additional stranded investment at RT(s) behind the DRP, as well as at the CO.

### **6.1.2. Discussion on category (b)**

Several solutions that fall into category (b) have been investigated and the results presented in T1E1.4. They have involved lowering of the entire power spectral density (PSD) mask (T1E1.4/2000-321 [16]), lowering portions of the PSD mask (T1E1.4/2000-321, 2001-080, -159, -160, -161 [16] through [20]) and limiting the maximum excess noise margin of deployed ADSL systems. (T1E1.4/2001-136, -137 [21] and [22])

All of these methods have been shown to reduce the amount of FEXT from RT-deployed ADSL into CO-deployed ADSL circuits. However, most of the techniques cannot be implemented using the currently deployed RT-based ADSL transceivers. Also, interoperability with the multitude of ADSL CPE modems appears to be problematic. More technical work is required to determine if viable solutions can be developed.

### **6.2. Technical Solutions using Alternate DSL technology**

DSL service from the CO to the customer could also be provided through the use of an alternate DSL technology that is relatively insensitive to the increased crosstalk due to the RT deployment (see 5.5). This capability could be provided at the CO through the use of interworking devices<sup>9</sup>. Solutions of this type could be applied in either a proactive or reactive manner.

Solutions that fall into this category include:

- Those that employ a pair of interworking devices (one at the CO and one at the customer location) to digitally transport both the POTS signals and DSL payload to the customer location where the CO-based interfaces are re-created, and
- Those that employ a dual-mode customer modem (ADSL plus alternate DSL technology) and a single CO-based interworking device (alternate DSL technology), operating in the frequencies above the voice band, to transport the ADSL payload using the alternate DSL technology.

These solutions can be implemented quickly when deployed on a line-by-line basis. However, while these solutions reliably provide broadband service, the data rates provided may not be as high as those offered by CO-based ADSL in the absence of RT deployments. Therefore, these solutions may only be of value on longer CO-based loops, where the alternate DSL technology can accommodate the lower ADSL target rates. There are concerns about operational issues and that such solutions are not economical in large scale. In addition, there are concerns with who would pay for the solution and whether it would have to be provided only for existing affected ADSL circuits, or future CO-deployments as well.

---

<sup>9</sup> An interworking device translates between ADSL (possibly along with voice) and an alternative DSL technology.

## *Remote Deployments of DSL: Advantages, Challenges, and Solutions*

### **7. Summary**

This paper has provided information on the background, technologies, architectures and major issues surrounding telecommunications access network evolution as it affects, and is affected by, wireline network spectral integrity. It specifically addressed the wireline network spectral integrity challenge created when DSL transceivers are deployed at locations remote from the central office (CO) yet within the potential reach of CO-based DSL transceivers.<sup>10</sup> It also offered options for possible solutions to the deployment of remote DSL transceivers.

Within NRIC-V FG3 there was unanimous agreement that where spectral compatibility problems occur due to the presence of remotely deployed DSL transceivers, a resolution to the problem needs to be available. However, there was disagreement on the following issues:

- 1) Whether these solutions would be employed
  - In a reactive manner, which implicitly assumes that the probability of a spectral compatibility problem is low, or
  - In a proactive manner, where solutions would be employed per the guidelines of T1.417-2001 [1] for CO-based DSL transceivers with the intent to keep spectral compatibility problems to a minimum.
- 2) Given the impact of the reactive solution on the customer of the CO-based service provider, what probability of a spectral compatibility problem is "low enough" to make the reactive solution broadly acceptable?
- 3) If the reactive approach is taken, would the service provider deploying the remote DSL transceivers (RT) be required to accommodate (i.e. ensure no disruption of service to) only those CO-based DSL transceivers installed at the time of the RT deployment, or would that party be responsible for all CO-based DSL transceivers, including those installed at any time after the RT deployment?
- 4) Which party would be responsible for the costs involved in providing proactive or reactive measures, either at the time of deployment or at any time after the deployment?

Because of the wide variety of loop architectures and their impact on the spectrum compatibility problem, NRIC-V FG3 was unable to reach consensus on a one-size-fits-all solution.

The paper aims to assist the FCC and the industry in managing this very complex and difficult problem by promulgating a consistent understanding of it.

### **8. References**

- [1] T1.417-2001 "Spectrum Management For Loop Transmission Systems: January, 2001"
- [2] T1E1.4/2001-060 "T1.417 provides compatibility for RT-Based xDSL systems" – Verizon: Trone Bishop (trone.t.bishop.jr@verizon.com (301) 236-3754)

---

<sup>10</sup> This problem has the potential to take on different forms as DSL transceivers are placed between RTs and the end user (e.g. FTTx, ONU or MTU architectures).

## *Remote Deployments of DSL: Advantages, Challenges, and Solutions*

- [3] T1.601 “ISDN Basic Access Interface for Use on Metallic Loops for Application at the Network Side of NT, Layer 1 Specification: July, 1999”
- [4] ITU-T Recommendation G.991.1 “High bit rate Digital Subscriber Line (HDSL) Transceivers” October 1998
- [5] ITU-T Recommendation G.991.2 “Single-Pair High-Speed Digital Subscriber Line (SHDSL) Transceivers” Approved, publication pending.
- [6] T1.422 “Single-Pair High-Speed Digital Subscriber Line (SHDSL) Transceivers: publication pending”
- [7] T1E1.4/2000-302 “Performance of CO Deployed ADSL due to Crosstalk from RT Deployed ADSL” - Rhythms, Copper Mountain: David Reilly (dreilly@rhythms.net 303 476-5717), Jack Yang (jyang@coppermountain.com 858-812-8107)
- [8] T1E1.4/2000-336 “Impact and Performance of Reduced Power RT-deployed ADSL” – Verizon: Dale Veeneman (dale.veeneman@verizon.com 781 466-2467)
- [9] T1.418-2000 “High Bit Rate Digital Subscriber Line - 2nd Generation (HDSL2): April, 2000”
- [10] T1.418-200x “High Bit Rate Digital Subscriber Line - 2nd Generation (HDSL2): publication of 2001 revision pending”
- [11] T1E1.4/2000-240 “Simulation of ADSL with Crosstalk from Remotely-Deployed SDSL” – Verizon: Dale Veeneman (dveeneman@gte.com 781 466-2467)
- [12] T1E1.4/2001-081 “Spectral Compatibility of RT-Based ADSL with Everything Except ADSL” – Telcordia: Kenneth Kerpez (kkerpez@telcordia.com (973) 829-4747)
- [13] T1E1.4/2001-069 “Data Relating to the Spectral Compatibility of Remote ADSL with CO-fed ADSL” – BellSouth: Gary Tennyson (gary.j.tennyson@bridge.bst.bls.com (205) 985 6087)
- [14] T1E1.4/2001-132 “Statistical Variables for Evaluating Compatibility of Remote Deployments” - Telcordia Technologies: Kenneth Kerpez (kkerpez@telcordia.com (973) 829-4747), Craig Valenti (cvalenti@telcordia.com (973) 829-4203)
- [15] T1E1.4/2001-179 “The Probability of RT-based ADSL Disturbing CO-based ADSL” - Telcordia Technologies: Kenneth Kerpez (kkerpez@telcordia.com (973) 829-4747)
- [16] T1E1.4/2000-321 “Spectrally Compatible RT-Based ADSL” - Telcordia Technologies, pursuant to work supported by BellSouth and SBC; Kenneth Kerpez (kkerpez@telcordia.com 973 829-4747)
- [17] T1E1.4/2001-080 “More Work on Spectrally Compatible RT-based ADSL” - Telcordia Technologies: Kenneth Kerpez (kkerpez@telcordia.com (973) 829-4747)
- [18] T1E1.4/2001-159 “Spectrally Compatible RT-based ADSL using Tone Masking and Flat Power Backoff” – Alcatel: Lane Moss (John.L.Moss@usa.alcatel.com (919) 850-1251)
- [19] T1E1.4/2001-160 “RT-fed ADSL: Examining mix crosstalk” – Alcatel: Lane Moss (John.L.Moss@usa.alcatel.com (919) 850-1251)
- [20] T1E1.4/2001-161 “Limitations on ADSL Notching and Power Backoff in G.992.1 and G.994.1” – Alcatel: Lane Moss (John.L.Moss@usa.alcatel.com (919) 850-1251)
- [21] T1E1.4/2001-136 “Performance related to reduction in NMR” – SBC: Clifford Yackle (cyackle@tri.sbc.com (512) 372-5654)

*Remote Deployments of DSL: Advantages, Challenges, and Solutions*

[22] T1E1.4/2001-137 “Reduction in NMR” – SBC: Clifford Yackle (cyackle@tri.sbc.com (512) 372-5654)

NOTE:

- Published and pre-published T1 Standards may be obtained at: <http://www.t1.org/html/standard.htm>
- Contributions to Working Group T1E1.4 are public documents however the readers attention is called to the “NOTICE” at the bottom of each contribution. These documents may be obtained at: <http://www.t1.org/filemgr/filesearch.taf>
- Published versions of ITU-T Recommendations may be obtained at: <http://www.itu.org>

## **Annexes**

### **A. Evolution of the Loop Architecture**

#### ***A.1. Overview***

The access network consists of the outside plant cable infrastructure and the drop that connects the cable to the premises wiring. Historically, outside plant cabling has been designed to support the transmission of voice grade signals with a useful bandwidth of between 3 and 4 kHz. The transmission path historically consisted of metallic paired cable. In the past decade, use of optical fiber has become a significant means of providing for new growth and for new services.

Metallic cable consists of pairs of solid copper conductors that are twisted together into units called pairs. During manufacturing, several pairs, usually in 25 pair complements (also called binders), are twisted together as separate bundles and the bundles are twisted together and wrapped in a polyethylene and aluminum jacket. When signals are transmitted across a pair, an electromagnetic field is created around the pair that is induced into other pairs in the same cable. As a result, a portion of the signal appears on neighboring pairs. This effect is called crosstalk. The greatest effect of crosstalk is within the same bundle. The twisting of the pairs and bundles tends to minimize coupling. However, the cable design was intended to minimize crosstalk around voice frequencies. DSL technologies use frequencies above the voice band. As the signals in copper cables increase in frequencies, crosstalk between pairs also increases. Simulation models that characterize this phenomenon are used to evaluate the effect of crosstalk on other services.

Optical fiber cable is also increasingly being used in place of metallic cable. Fiber is used because of its generally lower cost per line, greatly increased bandwidth capability, and lower maintenance costs than traditional copper plant. DSL applications generally permit much higher data rates when provided over facilities that include fiber.

The design of telephone cables between the local wire exchange and the customer is referred to as Outside Plant Design. Over the years, several sets of design rules for metallic cable have evolved. Many of the rules were developed before divestiture of AT&T in 1983, so there is a fair degree of consistency in their application throughout the country. Some variations will be noted in this document. This description is not exhaustive but is intended to cover the most common designs that are still in use today. It also describes some of the ramifications of using DSL bandwidths over voice-grade cable.

#### ***A.2. Resistance Design***

The conductors in metallic cable vary in thickness, or gauge. They typically range from 26 and 24 AWG (American Wire Gauge) for shorter cables to 22 and occasionally 19 AWG for the longest cables. Use of the minimum gauge necessary, to control the voice band loss to an acceptable level, results in the most economic design. Use of finer gauges for customers close to the central office is economical, allowing lower cost per loop and allowing higher densities of customers served in the same cable and over the same infrastructure of underground conduit, public and private easements, and pole lines. A simple way to implement this efficiency was through the use of Resistance Design rules. These rules allow a maximum

## *Remote Deployments of DSL: Advantages, Challenges, and Solutions*

of 1300 Ohms loop resistance<sup>11</sup>. For 26 AWG, this equates to about 15 kft, assuming a cable temperature of 90 degrees F. For longer loops, combinations of gauges are used that keep the total resistance within the 1300-Ohm limit. For non-loaded loops, the embedded base generally consists of 26 AWG out to about 15 kft and consists of a combination of 26 and 24 AWG from 15 kft out to the non-loaded loop limit. Resistance design also includes rules for permitting bridged taps. A bridged tap is any portion of the loop that is not in the direct path between the customer and the central office. For example, if a loop serving a particular home also extends beyond the home to the end of the street, that extension would be called a bridged tap. Bridged taps are commonly not limited to a single loop, but are consistent throughout the binder. An exception is noted for situations where the extension of a single loop beyond a customer terminal is sometimes removed to control bridged tap. In resistance design, any number of bridged-taps is allowed with a maximum combined bridged-tap length of less than 6 kft. According to loop surveys, most bridged taps are relatively short. In general, longer bridged taps have the greatest impact on voice frequency while shorter bridged taps have the greatest impact on ADSL frequencies.

Even with control of cable gauge and bridged-tap length, losses increase with frequency. For this reason, loops over 18 kft require inductors, commonly called load coils<sup>12,13</sup>. To reduce this loss near the telephony voice upper-band edge, inductors can be inserted in series with the loop at periodic intervals to reduce and flatten the voice-band loss. The first coil is placed at 3 kft from the central office and additional coils are placed every 6 kft thereafter. A minimum of 3 kft (12 kft maximum) is required between the last load coil and the customer. While load coils flatten the voice band attenuation response, it is at the expense of increasing attenuation above 3 kHz. This increase in attenuation makes DSL transmission over loaded loops difficult, if not impossible for most technologies. Loading coils are placed on cables in increments of 25 pair binders.

### ***A.3. Outside Plant Infrastructure***

Most cable plant designed in the last few decades is divided into feeder and distribution plant. Feeder plant extends from the wire center to a location that permits cross-connects to the distribution plant. Feeder cable is usually pulled through underground conduit in urban locations. Splice locations are accessible to permit splicing unused segments of one cable to other cables that need additional capacity. Bridged taps appear only occasionally on feeder cable. Distribution plant extends from the cross-connect box to the premises. It is not designed to be as flexible for rearrangements as feeder plant. This is because distribution plant is near the customer and must accommodate placement under sidewalks, fences, driveways and foliage. Rearrangements are usually disruptive and expensive. For this reason, distribution cable is sized so customers can order more than one line without need to rearrange the cable. Typically, this flexibility is enabled by use of bridged taps. Since the loop provider does not know how many lines a particular customer premises will require, bridged taps permit the same loops to pass by several homes so

---

<sup>11</sup> Many service providers use a set of rules called Revised Resistance Design (RRD) to determine loop gauge. While rules have changed over time, the current rules allow a maximum of 1300 ohms loop resistance for nonloaded loops and a maximum of 1500 ohms for loaded loops.

<sup>12</sup> In the past loading rules for some services, such as PBX trunks, required the application of two load coils on some loops less than 18 kilofeet in length.

<sup>13</sup> Additionally, single load coils are occasionally found on loops that were originally properly loaded, but at sometime in the past were re-arranged to serve an area closer to the CO. Apparently, for whatever reason, some of the load coils were not removed at the time of re-arrangement.



## *Remote Deployments of DSL: Advantages, Challenges, and Solutions*

that additional lines are available to whoever needs them. A Feeder-Distribution Interface (FDI) is used to connect feeder and distribution loops to form a working line between the wire center and the customer. In certain kinds of outside plant construction, the FDI is denoted as a Serving Area Interface (SAI).

### ***A.4. Carrier Serving Area Design***

In the early 1980s, Carrier Serving Area (CSA) rules were written for the design of distribution cable. CSA rules were originally written to enable the deployment of certain types of services without having to condition the loops. These services included voice grade specials, Digital Data Service, and switched 56 kb/s services. CSA rules allow a maximum of 9 kft for loops that contain any 26 AWG and allow a maximum of 12 kft for loops that contain only 24 AWG or coarser. A maximum of two bridged taps are allowed. A single bridged tap cannot exceed 2 kft and the combination of both bridged taps cannot exceed 2.5 kft. CSA bridged tap rules were intended to maximize voice-band performance; they do not address those bridged tap lengths that have the most impact on ADSL performance.

With the advent of DSL technologies, these rules were used to define performance objectives in the standardization process. Specifically, High-bit-rate Digital Subscriber Line (HDSL) (and its later versions) was designed to work on CSA loops. Performance objectives were also established for ADSL operating over CSA loops.

### ***A.5. Digital Loop Carrier***

In the 1980s, loop providers began provisioning access lines using a technology called Digital Loop Carrier (DLC). DLC was provisioned in place of new copper cables to provide for subscriber line growth. DLC entails the provisioning of channelized T-1 lines from the central office to a remote location near the FDI. A Central Office terminal (COT) is placed at the central office end and a Remote Terminal (RT) is placed near the FDI. The T-1 lines are repeatered every few kft. The length between repeaters varies with cable gauge and whether the upstream and downstream channels are in the same binder, adjacent binders, or non-adjacent binders. They carry time division multiplexed channels that carry voice grade (up to 3.4 kHz bandwidth) traffic. The terminals at each end multiplex and demultiplex traffic.

The DLC system described above is called a Universal DLC system. Later improvements replaced the T-1 lines with optical fiber and integrated the COT into the central office switch. In the 1990s, another improvement called Next generation Digital Loop Carrier (NGDLC) was deployed that uses time slot interchange (TSI) to make more efficient use of the channels during quiet periods. More recently, advances have been made to permit both DSL and voice over the DLC.

### ***A.6. Enclosures***

DLC systems typically employ battery backup. Early RT's (and their associated batteries) were typically deployed in pedestals and pole-mounted cabinets. As the demand for larger systems developed, RT's were deployed in huts and Controlled-Environment Vaults (CEV's). As the deployment of fiber moves closer to the customer, e.g., in Fiber To The Curb (FTTC) systems, the number of customers served via one remote site is smaller, thus resulting in smaller enclosures. These enclosures are designed to house the equipment that is planned for a specific forecast period, and thus there is often no space to accommodate unplanned equipment additions.

### ***A.7. Dual Provisioning with DLC and copper***

In some instances, DLC transport parallels existing copper feeder cable. At or near the RT, an FDI provides for connection to either the copper feeder cable or the feeder circuits provided via DLC. This

## *Remote Deployments of DSL: Advantages, Challenges, and Solutions*

arrangement allows the service provider to provide service to the customer via the copper plant or via the DLC remote terminal. This architecture permits DSL services to be served from the RT or, if the copper feeder is short enough, from the central office. Spectral compatibility issues may arise when remote DSL is used to serve areas that can also be served via the copper feeder.

See Figure 1 in Section 2 and LA#5 in Annex B for pictorial representations of this arrangement.

As loop architectures continue to evolve, concerns for wireline spectral integrity will continue.

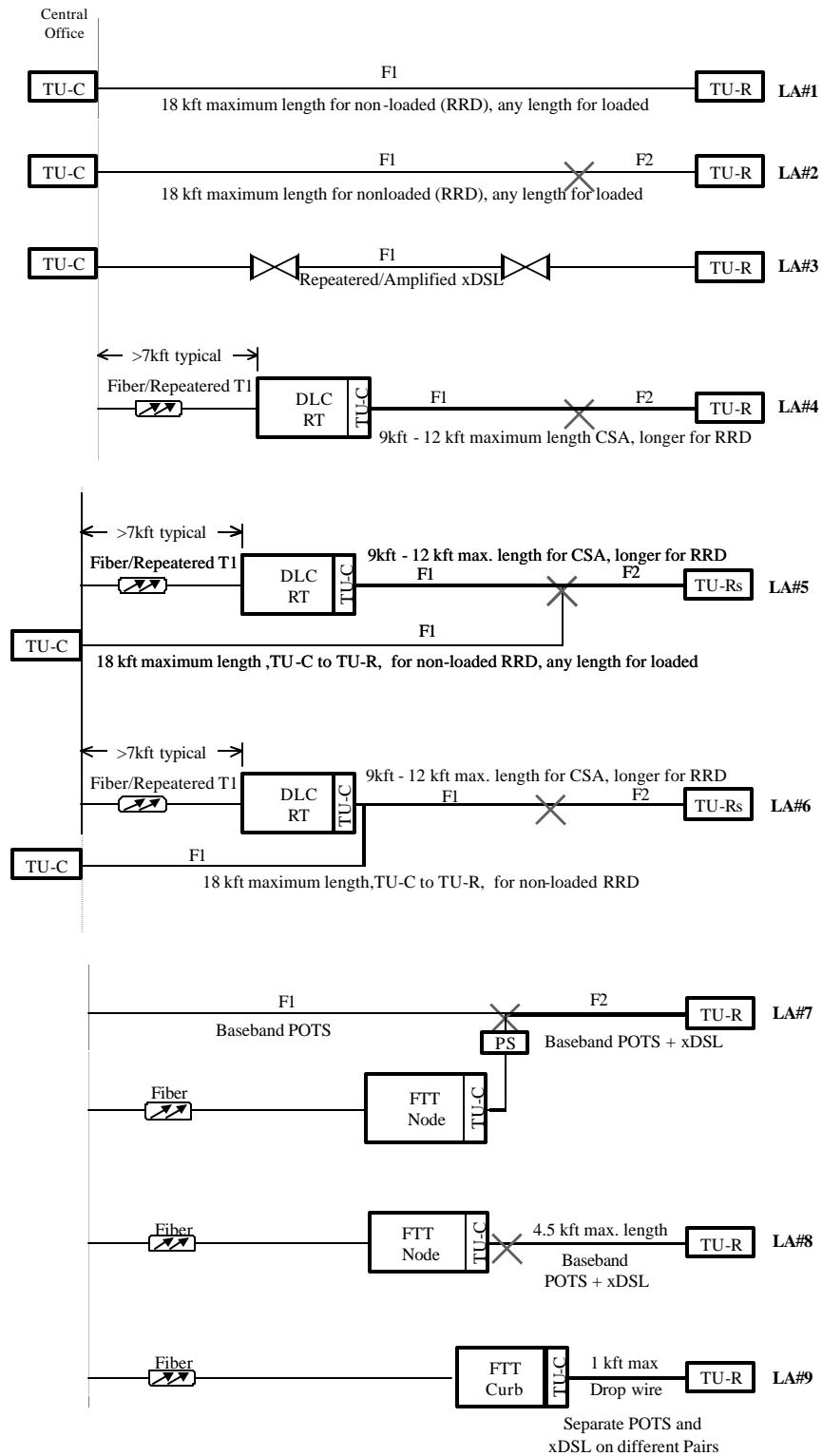
### **B. Loop Architectures**

This Annex describes the various DSL loop architectures, including remote TUs and repeaters. The loop architectures described include DSLs deployed

- Using direct metallic access from the CO
- With repeaters or amplifiers in the loop
- In or near RT cabinets at intermediate points in the loop plant, and
- At fiber ONUs at intermediate points in the loop plant or near the customer premises.

Figure 3 shows the different possible loop architectures.

## Remote Deployments of DSL: Advantages, Challenges, and Solutions



**Figure 3:** DSL Loop Architectures (LA).

## C. Crosstalk Simulation Models

### C.1. Crosstalk in the Loop Plant

Crosstalk generally refers to interference that enters a communication channel, such as a twisted wire pair, through some coupling path. The diagram in Figure 4 shows two examples of crosstalk generated in a multi-pair cable. On the left-hand side of the figure, signal source  $V_j(t)$  transmits a signal at full power on twisted wire pair  $j$ . This signal, when propagating through the loop, generates two types of crosstalk into the other wire pairs in the cable. The crosstalk that appears on the left-hand side,  $x_n(t)$  in wire pair  $i$ , is called near-end crosstalk (NEXT) because it is at the same end of the cable as the cross-talking signal source. The crosstalk that appears on the right-hand side,  $x_f(t)$  in wire pair  $i$ , is called far-end crosstalk (FEXT) because the crosstalk appears on the end of the loop opposite to the reference signal source. In the loop plant, NEXT is generally far more damaging than FEXT because NEXT has a higher coupling coefficient and, unlike far-end crosstalk, near-end crosstalk directly disturbs the received signal transmitted from the far-end after it has experienced the propagation loss from traversing the distance from the far-end down the disturbed wire pair.

In a multi-pair cable, relative to the wire-pair the desired receive signal, all of the other wire pairs are sources of crosstalk. For DSL systems, the reference cable size for evaluating performance in the presence of crosstalk is a 50 pair cable [2]. So by reviewing the example shown in Figure 4, we see that relative to the received signal on wire pair  $i$ , the other 49 wire pairs are sources of crosstalk (both near-end and far-end).

#### C.1.1. Near-end Crosstalk Model

As described in references [2,3,5 and 6], for the reference 50 pair cable, the near-end crosstalk *coupling* of signals into other wire pairs within the cable is modeled as

$$|H_{NEXT}(f)|^2 = c_{49} \times \left(\frac{N}{49}\right)^{0.6} \times f^{\frac{3}{2}}$$

where  $c_{49} = 8.818 \times 10^{-14}$  is the coupling coefficient for 49 NEXT disturbers,  $N$  is the number of disturbers in the cable, and  $f$  is the frequency in Hz. Note that the maximum number of disturbers in a 50 pair cable is 49. A signal source that outputs a signal with power spectral density  $PSD_{Signal}(f)$  will inject a level of NEXT into a near-end receiver that is

$$PSD_{NEXT}(f) = PSD_{Signal}(f) \times |H_{NEXT}(f)|^2$$

So as illustrated in Figure 4, if there are  $N$  signals in the cable with the same power spectral density  $PSD_{Signal}(f)$ , the PSD of the NEXT at the input to the near-end receiver on wire pair  $i$  is  $PSD_{NEXT}(f)$ .

Note from the above expressions that the crosstalk coupling is very low at the lower frequencies and the coupling increases at 15 dB per decade with increasing frequency. For example, at 80 kHz, the coupling

## *Remote Deployments of DSL: Advantages, Challenges, and Solutions*

loss is 57 dB for 49 disturbers. The loss (in dB) for 49 disturbers at other frequencies may be computed using the following formula:

$$L_{49} = 57 \text{ dB} - 15 \cdot \log\left(\frac{f}{80 \text{ kHz}}\right),$$

where  $L_{49}$  is the near-end crosstalk coupling loss in dB and  $f$  is the frequency in kHz.

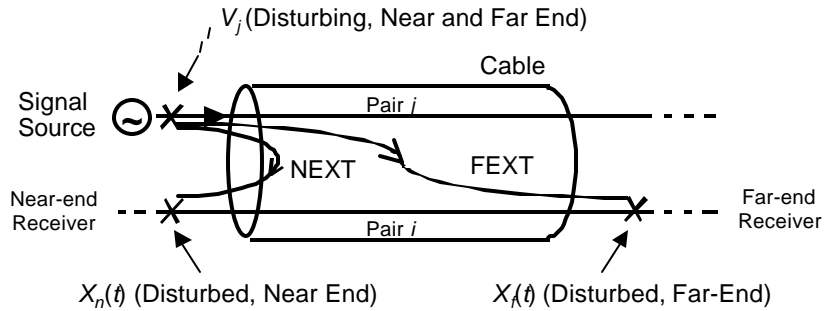
### **C.1.2. Far-end Crosstalk Model**

Correspondingly, in the same 50 pair cable, the far-end crosstalk coupling of signals into other wire pairs is modeled as

$$|H_{FEXT}(f)|^2 = |H_{channel}(f)|^2 \times \left(\frac{N}{49}\right)^{0.6} \times k \times l \times f^2$$

where  $H_{channel}(f)$  is the channel transfer function,  $k = 8 \times 10^{-20}$  is the coupling coefficient for 49 FEXT disturbers,  $N$  is the number of disturbers,  $l$  is the coupling path length in feet, and  $f$  is the frequency in Hz.

Note that the coupling is small at low frequencies and large at higher frequencies. The coupling slope increases at 20 dB/decade with increasing frequency.



**Figure 4:** NEXT and FEXT in a multi-pair cable.

### **C.2. Applications that use Intermediate TU Devices**

In some instances it may be desired to evaluate the effect of interference from systems that use intermediate (TU-I) devices between the CO and CI to another system. In these cases, the TU-I is integrated in to the same binder at some intermediate point between the CO and the CI such as may be the case in DLC deployments. In this case, crosstalk from the intermediate TU system will and affect the CO based system. The reverse is generally not of concern because the intermediate TU system benefits from higher signal levels as a result of the shorter path for the signals in the intermediate TU system.

The configuration in Figure 5 shows the sources of the crosstalk that are represented in the simulation model for the basis system downstream receiver.

## *Remote Deployments of DSL: Advantages, Challenges, and Solutions*

### **C.2.1. Interference into the Basis System Downstream Receiver**

The model in Figure 6 should be used when performing a computer simulation of the effect of the new technology intermediate TU-I system NEXT and FEXT interference into the basis system downstream receiver.

Assumptions:

- The TU-I will integrate with the CO based binders at an intermediate point between the CO and the CI, such as at the FDI (or SAI).
- The head-end transmitters (TU-Cs) for the two systems are not co-located.
- All customer premises transmitters (TU-Rs) for both systems are co-located.
- The binders are contiguous for the purposes of demonstrating spectral compatibility with the exception of the TU-I integration

The first cable section is adjusted to cover the distance from the CO based TU-C to the intermediate TU-I, ( $Z-D$  ft), and the second cable section is adjusted to cover the remaining length ( $D$  ft) of the test loop under consideration. The new technology New TU-I FEXT noise is equivalent to the New TU-I output signal passed through the FEXT coupling loss, using a coupling length equal to the second cable section (labeled  $Z - Y - A + D$  ft). The resulting FEXT coupling equation for this second cable section is expressed by

$$|H_{FEXT}(f)|^2 = |H_{L1}(f)|^2 \times \left(\frac{N}{49}\right)^{0.6} \times k \times L2 \times f^2$$

where  $H_{L1}(f)$  is the transfer function of the cable section from the New TU-I to the New TU-R,  $N$  is the number of disturbers,  $k = 8 \times 10^{-20}$  is the coupling coefficient for 49 FEXT disturbers,  $L2 = D = Z - Y - A$  is the coupling path distance in ft, and  $f$  is the frequency in Hz.

### **C.2.2. Interference into the Basis System Upstream Receiver**

The model in Figure 7 should be used when performing a computer simulation of the effect of the intermediate TU-C system new technology NEXT and FEXT interference into the basis system upstream receiver.

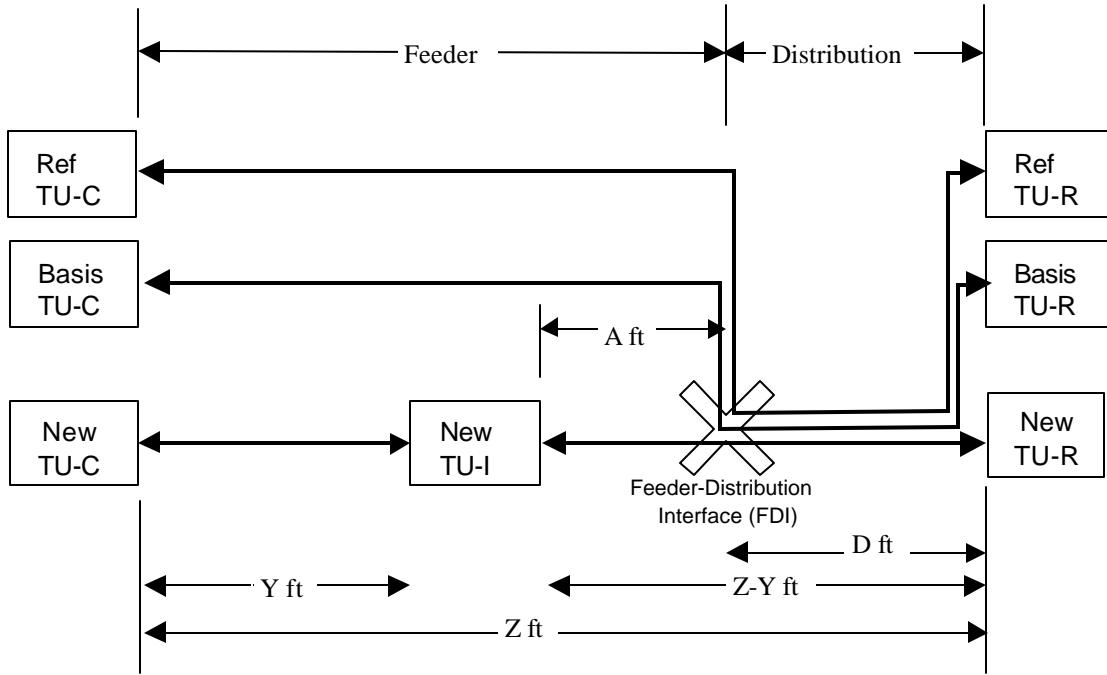
Assumptions:

- The intermediate TU-I will integrate with the CO based binders at an intermediate point between the CO and the CI.
- The head-end transmitters (TU-C) for the two systems are not co-located.
- The customer premises transmitters (TU-R) for both systems are co-located.
- The binders are contiguous for the purposes of demonstrating spectral compatibility with the exception of the TU-I integration.

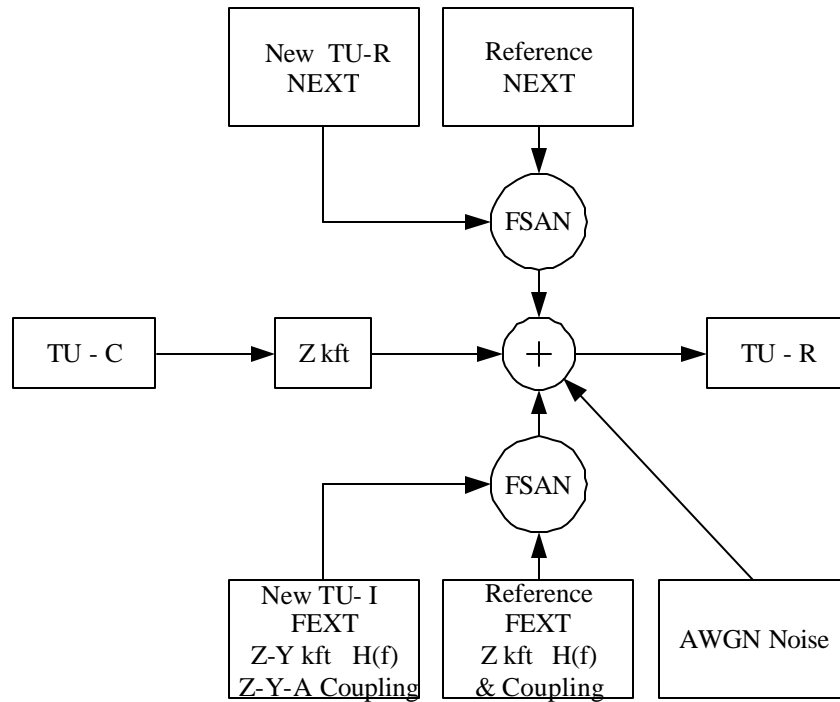
The first cable section is adjusted to cover the distance from the CO based TU-C to the TU-I, and the second cable section is adjusted to cover the remaining length of the test loop under consideration. The new technology New TU-R FEXT noise is equivalent to a New TU-R output signal passed through the FEXT coupling loss, using a coupling length equal to the second cable section. The New TU-R FEXT

**Remote Deployments of DSL: Advantages, Challenges, and Solutions**

noise is attenuated by the first cable length. The new technology New TU-C NEXT noise is determined by the New TU-C output signal. The New TU-C NEXT noise is attenuated by the first cable length.

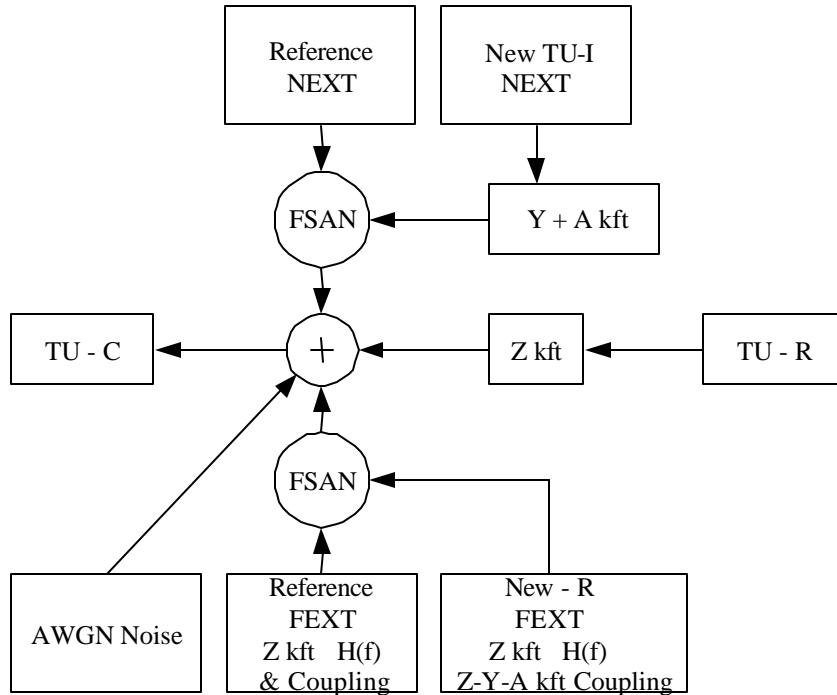


**Figure 5:** NEXT & FEXT from New TU-I into TU-R.



*Remote Deployments of DSL: Advantages, Challenges, and Solutions*

**Figure 6:** Model for Reference and New Crosstalk into TU-R with New TU-I Device.



**Figure 7:** Model for Reference and New Crosstalk into TU-C with New TU-I Device.