

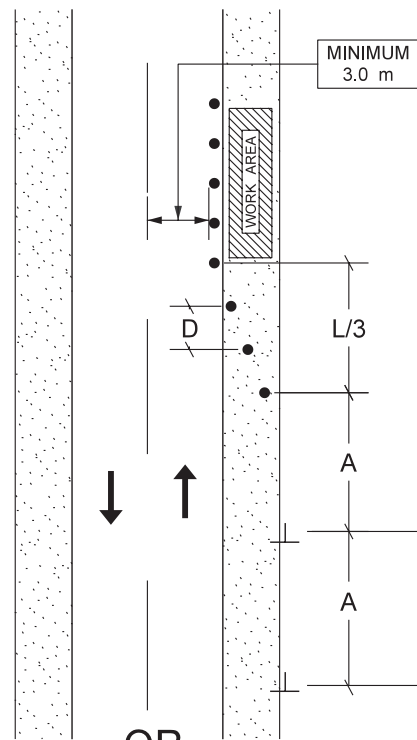

ENCROACHMENT IN RIGHT LANE



S(km/h)	A(m)	L(m)	B(m)	D(m)
50	50	60	35	15
60	50	90	45	15
70	75	120	50	15
80	100	175	55	15
90	100	200	65	20
100	150	250	70	20

WHERE:

S = SPEED LIMIT

A = SPACING BETWEEN SIGNS

L = LENGTH OF TAPER

B = LENGTH OF LONGITUDINAL BUFFER SPACE

D = SPACING BETWEEN DELINEATION DEVICES



WHERE REQUIRED
(SEE POLICY 900-C-6)



OR

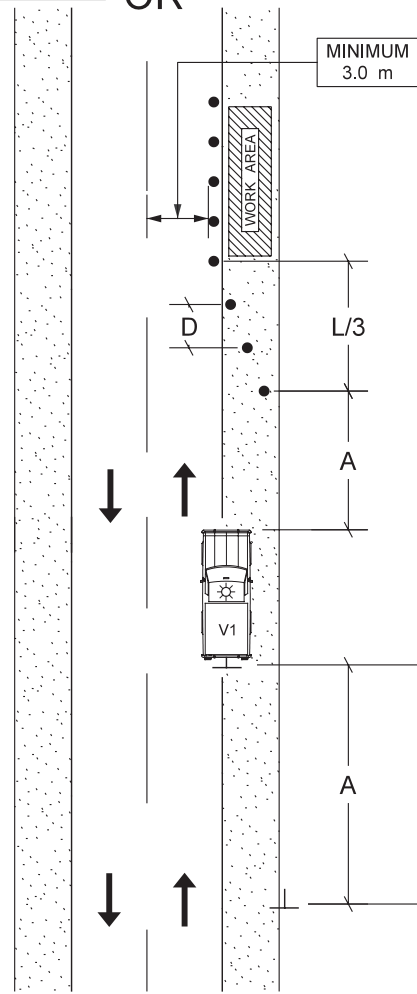

360° BEACON
AND
4-WAY FLASHERS

OR

FLASHING ARROW
BOARD

NOTE: NON-DIRECTIONAL
NO ARROW MODE ONLY

