TABLE OF CONTENTS

Letter Carrier Presort

1	Overview	1
1.1	Who Should Use This Guide	1
1.1.1	What is Mail Presortation and Preparation?	1
1.1.2	What is Letter Carrier Presort (LCP)?	1
1.2	Requirements for Letter Carrier Presort	2
1.3	Information Sources	3
2	What You Need to Know Before You Start	3
2.1	The Postal Code	3
2.2	Delivery Mode Code	4
2.2.1	Delivery Mode Audit Code	5
2.2.2	Delivery Mode Details	5
2.2.3	Placement of Delivery Mode Code	6
2.3	Alphanumeric Sequencing	7
2.3.1	Alphanumeric Sequencing by Delivery Mode Details	7
2.3.2	Sequencing by Postal Code	8
2.4	National Presortation Schematic (Non-Lettermail)	9
2.4.1	Levels of Access for Groupings	10
2.4.2	Using Containers	10
2.5	Electronic Shipping Tools	11
2.6	Steps for Letter Carrier Presort	11
3	Sequence the Mail (Step 1)	11
3.1	Sequencing Urban Mail (Level 1)	12
3.2	Sequencing Rural Mail (Level 1)	13
3.3	Sequencing Mail by DCF (Level 3)	13
3.4	Sequencing Mail by FCP (Level 4)	14
4	Group the Mail (Step 2)	15
4.1	Grouping Elements	15
4.2	Grouping Urban Mail (Level 1)	16
4.3	Grouping Rural Mail (Level 1)	16
4.4	Grouping Mail for DCF (Level 3)	17
4.5	Grouping Mail for FCP (Level 4)	18
4.6	Grouping Mail for Residue	19
4.7	Segregating Groupings	19
4.7.1	Separator Cards	20
4.7.2	Edgemarking	21
4.7.3	Bundling	22
4.7.3.1	Single-Strapping (Hardsided Containers)	22
4.7.3.2	Double-Strapping (Bags and Hardsided Containers)	23
4.7.3.3	Shrink-wrapping	23
4.7.3.4	Uneven Spines	23
4.7.4	Labelling Bundles	24
4.7.4.1	Bundle Label Specifications	24
4.7.4.2	Labels for Distribution Centre Facility (DCF) Bundles	24
4.7.4.3	Labels for Forward Consolidation Point (FCP) (Level 4) Bundles	25

- 4.7.5 Labelling Residue Groupings 25
- 5 Place Groupings in Containers (Step 3) 26**
 - 5.1 Hardsided Containers 26
 - 5.1.1 Hardsided Container Fill Requirements 27
 - 5.1.2 Dealing with Leftover Mail Items for Hardsided Containers 28
 - 5.2 Bags 29
 - 5.3 Levels of Containerization 30
 - 5.3.1 Rules for Consolidating Mail in Containers 31
 - 5.4 Sequencing Groupings within Hardsided Containers 31
 - 5.4.1 Residue Containers 32
- 6 Label the Containers (Step 4) 33**
 - 6.1 Labels/Tags, Service and Routing Information 33
 - 6.1.1 NPS Routing Information 34
 - 6.1.2 Labelling Residue Containers 36
 - 6.2 Labelling Hardsided Containers 37
 - 6.3 Labelling Bags 37
 - 6.3.1 Vinyl Label Holders 37
 - 6.3.2 Tie-on Tags and Bag Labels (Keeper Tags) 38
 - 6.4 Producing Labels and Tie-on Tags 39
 - 6.4.1 Special Instructions for Producing Labels 39
- 7 Make Up Monotainers and Pallets (Step 5) 40**
 - 7.1 Using the NPS to Make up Monotainers and Pallets 41
 - 7.2 Labelling Monotainers and Pallets 43
- 8 Prepare the Mailing Summary (Step 6) 44**
 - 8.1 What is a Mailing Summary? 44
 - 8.1.1 General Information 45
 - 8.1.2 Software Name and Version 45
 - 8.1.2.1 Software Parameters 45
 - 8.2 Mailing Details 45
 - 8.3 Letter Carrier Volume Summary (Dimensional Addressed Admail only) 46

LETTER CARRIER PRESORT

Canada Post has made every reasonable effort to ensure the information provided in this Guide is accurate at the time of publication. For further details, Customers should refer to their Agreement and other sources. See section 1.3 "Information Sources" on page 3 for other information sources.

Notice for Developers of Presortation Software: If there is any discrepancy between this Guide and the *Presortation Technical Specifications* (PTS), the PTS takes precedence.

1 OVERVIEW

1.1 Who Should Use This Guide

This Guide is for Canada Post Customers that use presortation software to explain how to do Letter Carrier Presort (LCP) for the following services:

- Addressed Admail (AA), including Dimensional Addressed Admail (DAA); and
- Publications Mail.

Visit www.canadapost.ca/customer_guides documents for a list of support documents detailing the requirements, qualifications, terms and conditions and pricing.

1.1.1 WHAT IS MAIL PRESORTATION AND PREPARATION?

Mail preparation is the process of facing and containerizing the items and labelling the containers. It helps ensure machineability of mail (where applicable), protection of mail, identification of the type of mail and ease of handling.

Mail presortation is the process of sequencing, grouping and containerizing the items and labelling the containers to allow Canada Post to bypass various processing steps and facilities within its mail distribution network.

1.1.2 WHAT IS LETTER CARRIER PRESORT (LCP)?

The LCP option allows Customers to presort items to specific letter carrier walks (or other delivery routes) using Delivery Mode Codes and presortation software recognized by Canada Post, allowing Canada Post to bypass various processing steps and facilities within its mail distribution network.

1.2 Requirements for Letter Carrier Presort

To qualify for LCP presortation:

- the mailing must consist of at least 1,000 items
- the mail items must be mailed in Canada for delivery in Canada
- the mail items must meet all Canada Post requirements for service and type of mail such as size and weight. Consult the appropriate *Customer Guide* (see section 1.3 “Information Sources” on page 3)
- the mail items must meet any requirement specified in the Agreement, the Presort Technical Specifications and the *Canada Postal Guide*, and
- the mailing must use presortation software recognized by Canada Post.

Commingling of Letter Carrier Presort items is not permitted. Commingling occurs when a number of separate and notably different mailings are combined to achieve the minimum deposit requirement or sufficient densities to achieve discount prices.

Table 1: Letter Carrier Presort Key Requirements

KEY REQUIREMENTS	ADDRESSED ADMAIL	PUBLICATIONS MAIL
Minimum volume per deposit*	1,000 items per Order	
Mail type	<ul style="list-style-type: none"> • Addressed Admail: Short and Long (S/L) & Oversize (O/S) • Dimensional Addressed Admail: Small, Medium and Large 	<ul style="list-style-type: none"> • S/L & O/S
Delivery Mode Code required	Yes	
Minimum items per grouping (except Residue)	8 items	6 items
Levels of consolidation (groupings)	<ul style="list-style-type: none"> • Delivery Mode (“Direct to walk” level) • Urban Delivery Facility/Rural Delivery Facility – Level 1 • Distribution Centre Facility (DCF) – Level 3 • Forward Consolidation Point (FCP) – Level 4 • Residue 	<ul style="list-style-type: none"> • Delivery Mode (“Direct to walk” level) • Urban Delivery Facility/Rural Delivery Facility – Level 1 • Distribution Centre Facility – Level 3 • Forward Consolidation Point – Level 4 • Residue
Levels of consolidation (containers)	<ul style="list-style-type: none"> • Urban Delivery Facility/Rural Delivery Facility – Level 1 • City – Level 2 • Distribution Centre Facility (DCF) – Level 3 • Forward Consolidation Point (FCP) – Level 4 • Residue 	<ul style="list-style-type: none"> • Urban Delivery Facility/Rural Delivery Facility – Level 1 • City – Level 2 • Distribution Centre Facility – Level 3 • Forward Consolidation Point – Level 4 • Residue
Container requirements	<ul style="list-style-type: none"> • lettertainer: S/L AA, small and medium Dimensional AA • flats tub: O/S AA and large Dimensional AA • bag: S/L & O/S AA (bags cannot be used for Dimensional AA) • consolidating containers on monotainers or pallets mandatory for Dimensional AA 	<ul style="list-style-type: none"> • lettertainer: S/L • flats tub: O/S • bag: S/L & O/S
Address Accuracy**	Deposits in excess of 5,000 items	
Machine readability	Not applicable	

* Phantom Pricing, that is, charges for mail volumes that the Customer commits to but does not meet, will be applied to mailings that do not meet the minimum deposit requirement.

** Address Accuracy is a program designed to improve delivery by encouraging Customers to accurately address mail. The standard for Address Accuracy is 95%. This means that 95% of the addresses on the Customer's database are determined to be valid. This is done by using a Canada Post-recognized address validation and/or address validation and correction software. If the percentage on the *Statement of Accuracy* (SOA) produced by the software is less than 95%, an adjustment will be applied to the mailing.

1.3 Information Sources

This *Mail Preparation and Presortation Guide* forms part of the Agreement noting that the *Canada Postal Act and Regulations* takes precedence, then the Customer's Agreement, then the *Customer Guide*, then the *Canada Postal Guide*.

Table 2: Quick Reference Chart

INFORMATION SOURCES	WEB ADDRESSES
<i>Address Accuracy Program Customer Guide</i>	www.canadapost.ca/am
Addressed Admail support documents	www.canadapost.ca/aasupportdocuments
Artwork for postal indicia and container labels	www.canadapost.ca/postalservices
<i>Canada Post Act and Regulations</i>	laws.justice.gc.ca/en/C-10/index.html
<i>Canada Postal Guide</i>	www.canadapost.ca/postalguide
Canadian Postal Standards	www.canadapost.ca/postalstandards
<i>Customer Guide</i> (including all amendments)	www.canadapost.ca/customer_guides
Delivery Mode Data Product (updated monthly; also available on CD-ROM)	www.canadapost.ca/offerings/address_management/can/other_data-e.asp
Electronic Shipping Tools	www.canadapost.ca/obc
Glossary of Canada Post terms	www.canadapost.ca/postalservices
<i>Mail Preparation and Presortation Guides</i>	www.canadapost.ca/mailpreparation
National Presortation Schematic (LPNS)	www.canadapost.ca/nps
Publications Mail support documents	www.canadapost.ca/pmsupportdocuments
Recognized Presortation and Bar Code Recognition Software	www.canadapost.ca/am_list
Recognized Software: Address Accuracy, Validation and Correction and Postal Code Lookup	www.canadapost.ca/common/offerings/address_management/pdf/addaccu-e.pdf

2 WHAT YOU NEED TO KNOW BEFORE YOU START

This section explains basic information on postal codes, Delivery Mode Codes, alphanumeric sequencing and the National Presortation Schematic (NPS) that the Customer needs to know for preparing Letter Carrier Presort (LCP) mailings.

2.1 The Postal Code

The postal code is an integral part of every postal address in Canada. It was designed to aid in sorting mail by both mechanized and manual methods.

The postal code is a six-character, alphanumeric code in the form of ANA NAN in which "A" represents a letter of the alphabet and "N" represents a number.

For example, the postal code **M4B 1G5** is made up of two segments (as shown in Figure 1).

Figure 1: Postal Code Segments

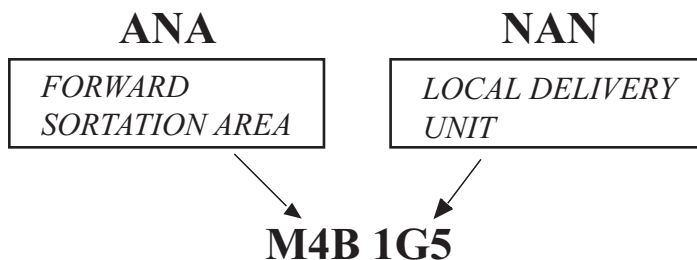

The first segment (the first three characters) represents a Forward Sortation Area (FSA). The first letter indicates which major geographical region (as shown in Table 3).

Table 3: Major Geographical Regions

FIRST LETTER OF POSTAL CODE	GEOGRAPHICAL REGION	FIRST LETTER OF POSTAL CODE	GEOGRAPHICAL REGION
A	Newfoundland	M	Metropolitan Toronto
B	Nova Scotia	N	Southwestern Ontario
C	Prince Edward Island	P	Northern Ontario
E	New Brunswick	R	Manitoba
G	Eastern Québec	S	Saskatchewan
H	Metropolitan Montreal	T	Alberta
J	Western Québec	V	British Columbia
K	Eastern Ontario	X	Northeast Territories Nunavut Territory
L	Central Ontario	Y	Yukon

The second segment represents a Local Delivery Unit (LDU). It identifies the smallest delivery unit within an FSA. In urban areas, the LDU may indicate a specific city block (one side of a street between two intersecting streets), a single building or, in some cases, a large-volume mail receiver. In rural areas (as indicated by the zero in the FSA), the LDU combines with the FSA to identify a specific rural community.

For more information on postal codes, visit www.canadapost.ca/postalguide under Addressing.

2.2 Delivery Mode Code

The Delivery Mode Code (DMC) appears to the right of an address (as shown in Figure 2) and identifies a specific type of delivery and a specific delivery route for urban mail. The DMC is required on each item of urban mail for LCP presortation.

Figure 2: Delivery Mode Code

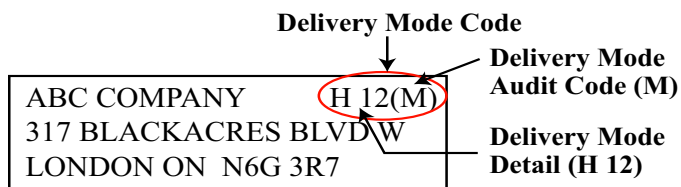

The DMC consists of the Delivery Mode Audit Code and Delivery Mode Details (DMDs).

2.2.1 DELIVERY MODE AUDIT CODE

The Delivery Mode Audit Code is required on all urban and rural mail for LCP.

The Delivery Mode Audit Code identifies which version of the Delivery Mode Data was used to prepare a mailing. The Delivery Mode Audit Code is a code that appears on the mail item and changes every five to six weeks. It allows a Receipt Verification Unit (RVU) to identify if the Customer is using the current presort tape. The Delivery Mode Audit Code must be placed in parentheses (as shown in Figure :2 “Delivery Mode Code” on page 4).

2.2.2 DELIVERY MODE DETAILS

The DMD is a combination of alphabetical and/or numerical characters representing a particular type of mail delivery in an urban area. The DMD includes the Delivery Mode type (e.g., H) and the Delivery Mode Details (as shown in Figure 2). There is no DMD for rural postal codes.

The purpose of the DMD is to establish how to group items, that is, items with the same DMD will be grouped together. For LCP groupings that have fewer than the minimum required number of items bearing the same DMD (as shown in Figure 3), the software will print two Xs (XX) immediately to the left of the DMD. The two Xs indicate that the grouping contains items for more than one DMD.

Figure 3:

Example

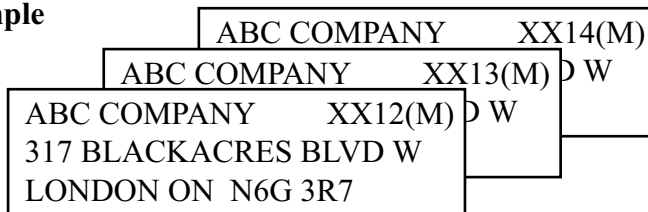

The alphabetic characters of the DMD denote the Delivery Mode type. Delivery Mode types are indicated by the following letters:

A = Delivery to a block face address

B = Delivery to an apartment building

E = Delivery to a business building

G = Delivery to a large-volume receiver

H = Delivery via a rural route

J = General Delivery

K = Delivery to a Post Office box (PO Box), not a community mail box (CMB)

M = Delivery to a large-volume receiver (PO Box)

T = Delivery via a suburban service

X = Delivery via a mobile route

Z = Postal code is retired (No further delivery to this code. The Customer needs to segregate this mail in Residue and pay a higher rate.)

The letter denoting Delivery Mode type is not always required. For instance, it is possible that the same Letter Carrier can serve A, B, E and G. In this case, because the software groups the four Delivery Mode types together to the same Letter Carrier Route – that is, the numeric characters – it will not print the alphabetic character denoting the Delivery Mode type (as shown in Figure 4).

Figure 4: Delivery Mode Type

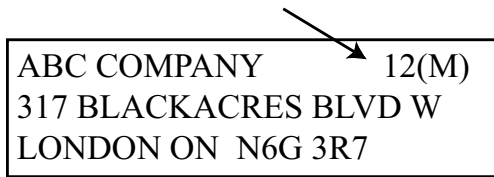

2.2.3 PLACEMENT OF DELIVERY MODE CODE

A DMC can appear up to two lines above the address block or three to four blank spaces to the right of any line in the address block that does not contain the delivery address information, that is, lines containing company and personal names and titles, and building names. It cannot appear on the same line as street addresses, city or province names, or postal codes.

Examples of placement are shown in Figure 5, Figure 6, and Figure 7.

Figure 5: DMC Placement – Example 1

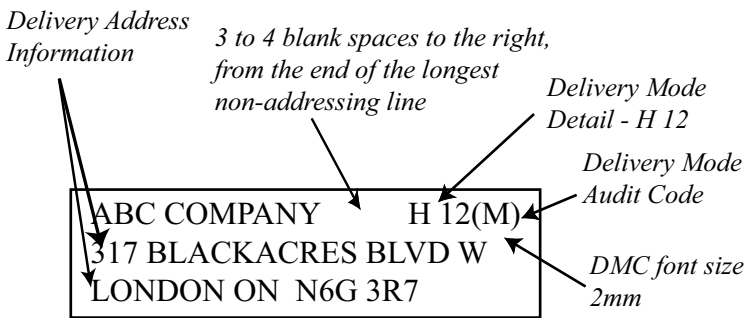

Suitable for addresses with three (or more) lines.

Figure 6: DMC Placement – Example 2

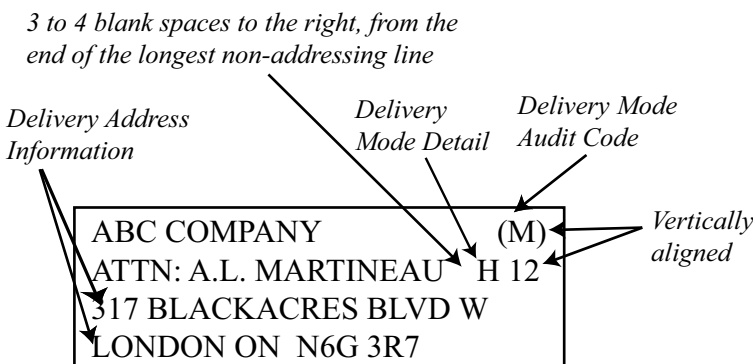

Suitable for addresses with four (or more) lines.

Figure 7: DMC Placement – Example 3

Up to two lines above the address block,
3 to 4 blank spaces to the right, from the
end of the longest non-addressing line

Delivery Mode Detail (H 12)

Delivery Mode Audit Code (M)
represents the version of the
Delivery Mode Data product.
The use of parentheses is
required around the Audit Code

H 12(M)
ABC COMPANY
317 BLACKACRES BLVD W
LONDON ON N6G 3R7

Suitable for placement of DMC above the address block.

2.3 Alphanumeric Sequencing

2.3.1 ALPHANUMERIC SEQUENCING BY DELIVERY MODE DETAILS

At a minimum, Canada Post requires that groupings be sequenced by the DMDs in alphanumeric order. Within DMDs, they can then be sorted by FSA, and then LDU.

The software first sorts records with DMDs that have numeric characters only in numerical, ascending order (e.g., 1, 2, 3, etc.). It then sorts records with DMDs that have alphabetical characters in the left-most positions alphabetically, in ascending order and then by any numerical characters in numeric, ascending order (e.g., CF, DIR, GD, H1, H10, H11, etc.).

For overall sequencing of DMDs, ascending order is preferred. If the Customer prefers descending order, that is acceptable as long as the entire mailing is in descending order (as shown in Table 4).

Table 4: Examples of Alphanumeric Sequencing of DMDs

ASCENDING ORDER	DESCENDING ORDER
1	T11
2	T10
3	T1
4	RET
5	P2
6	P1
7	H11
CF	H10
GD	GD
H1	DIR
H10	CF
H11	11
P1	10
P2	5
RET	4
T1	3
T10	2

2.3.2 SEQUENCING BY POSTAL CODE

This type of sequencing is done after sortation by DMD. This is usually done by the software.

When sequencing by postal code, first sequence by the FSA (the first three characters) according to the NPS (as shown in Figure 8).

Figure 8: Example of Sequencing by FSA

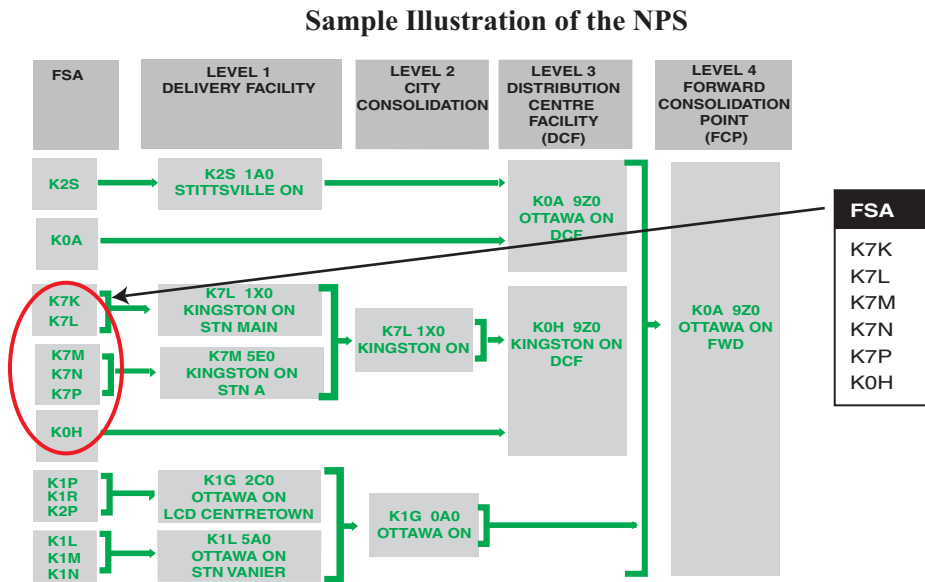

NOTE: Canada Post updates the National Presentation Schematic (NPS) monthly. The NPS sample illustrations may not reflect the current NPS. To receive optimal service, Customers must use the current version of the NPS.

Then, within each FSA, sequence by LDU (the last three characters of the postal code; as shown in Table 5).

Table 5: Example of Alphanumeric Sequencing by LDU

FSA	LDUS WITHIN THE FSA		
K1A	1A1	4A9	5C9
	1A2	4B1	5H1
	1A4	4B3	5J6
	1B1	4B8	6L4
	1B2	4C2	6L9

2.4 National Presortation Schematic (Non-Lettermail)

The National Presortation Schematic (NPS) has two schematics: for Lettermail and for Non-Lettermail. Customers must use the correct NPS, depending on the type of mail to be sorted.

The NPS is a set of tables that indicates how to consolidate mail through Canada Post's mail distribution network, beginning with the FSA.

The NPS is used for all Canada Post presortation processes, including Letter Carrier Presort. The NPS has four levels of access:

- Level 1 – Delivery Facility;
- Level 2 – City;
- Level 3 – Distribution Consolidation Facility (DCF); and
- Level 4 – Forward Consolidation Point (FCP).

Following the NPS levels of access is key to sequencing, grouping, containerizing and labelling mail for presortation (as shown in Figure 9).

Figure 9: Illustration of the NPS

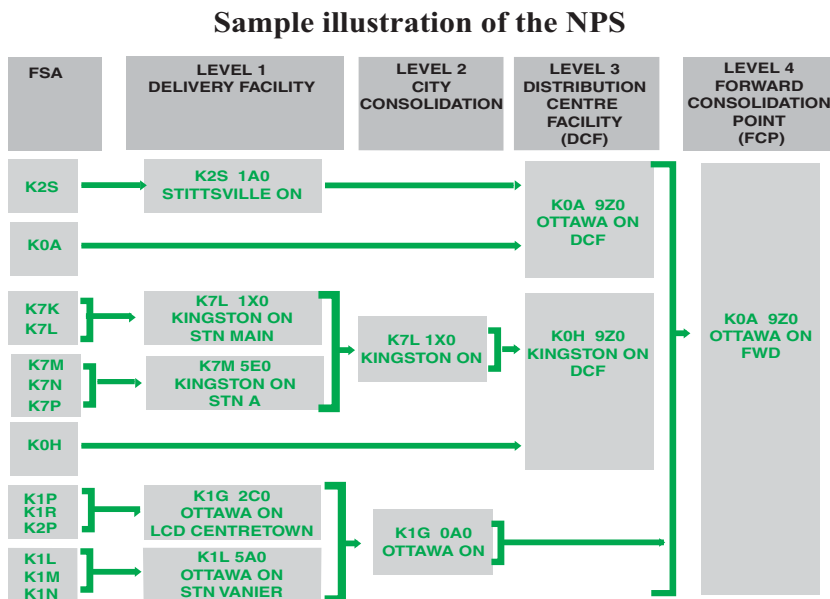

NOTE: Canada Post updates the National Presortation Schematic (NPS) monthly. The NPS sample illustrations may not reflect the current NPS. To receive optimal service, Customers must use the current version of the NPS.

To avoid delays and extra handling charges, the Customer must use the current version, available on the Canada Post website at www.canadapost.ca/nps.

2.4.1 LEVELS OF ACCESS FOR GROUPINGS

Figure 10 shows the NPS levels of access for grouping mail for LCP presortation. Addressed Admail and Dimensional Addressed Admail require a minimum of eight items to create a grouping. Publications Mail requires a minimum of six items to create a grouping. If there are not enough items for a DMD grouping, consolidate to Level 1; if there are not enough items for that level, consolidate to Level 3; if there are not enough items for that level, consolidate to Level 4; if there are still not enough items, consolidate to Residue.

Figure 10:

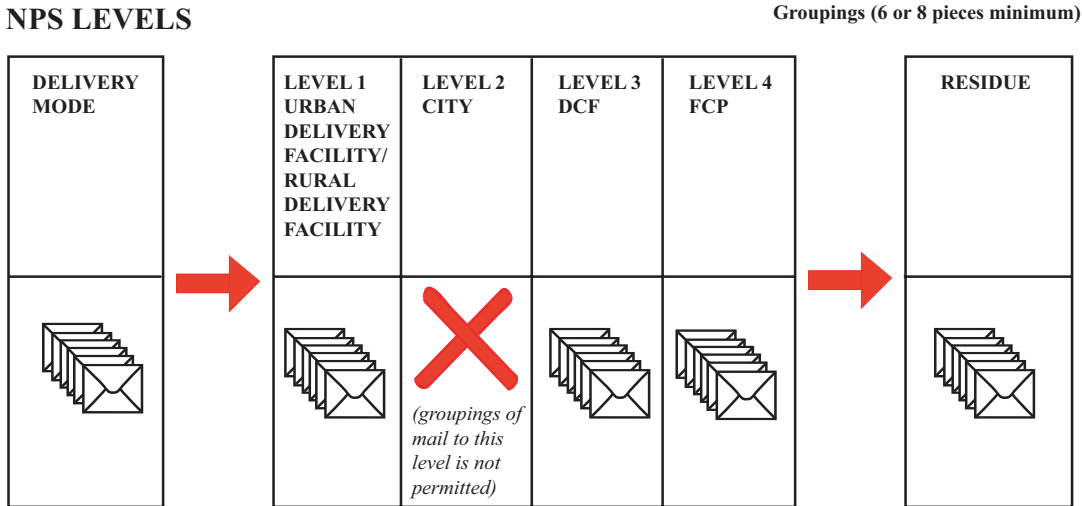

NOTE: Addressed Admail and Dimensional Addressed Admail require a minimum of eight (8) items to create a grouping. Publications Mail requires a minimum of six (6) items to create a grouping.

2.4.2 USING CONTAINERS

The Customer consolidates groupings in containers. The NPS groupings that the Customer places in a container determine the container’s NPS access level. For example, when there are not enough groupings for Level 1 consolidation, consider preparing a container for a Level 2 consolidation. Figure 11 shows the NPS access levels for containerization of mail (see section 5 “Place Groupings in Containers (Step 3)” on page 26 for more information).

Figure 11:

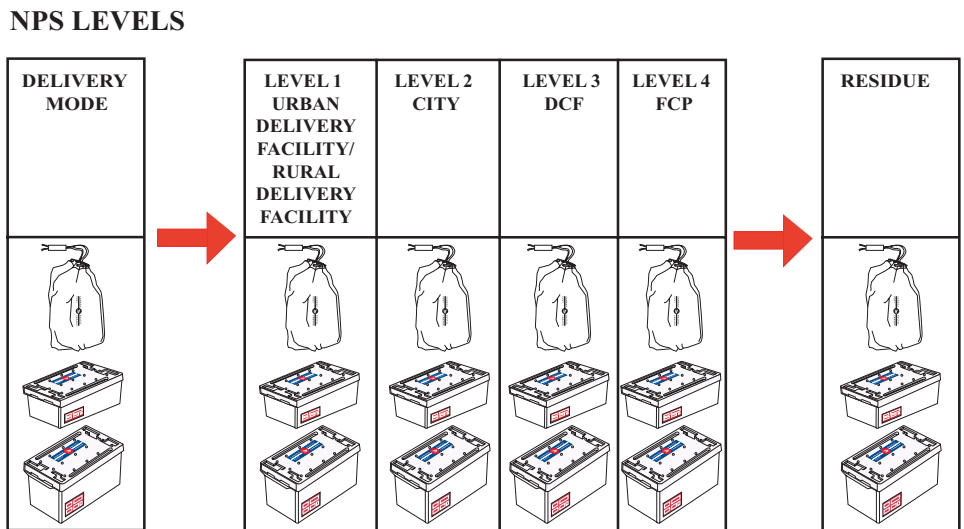

NOTE: Bags are not permitted for Dimensional Addressed Admail.

2.5 Electronic Shipping Tools

Customers can obtain the Electronic Shipping Tools (EST), free of charge, by registering for a user ID and password at www.canadapost.ca/obc. For technical inquiries regarding the Electronic Shipping Tools (EST), please call the Technical Help Line at 1-800-277-4799.

Customers have the option of using either the Electronic Shipping Tools (EST) online, or the desktop version, which can be downloaded to prepare *Orders* offline and submitted later. This method reduces paperwork and opportunities for error, while providing added Customer convenience. Visit www.canadapost.ca/obc for more information.

2.6 Steps for Letter Carrier Presort

The essential steps for LCP presortation are:

1. **Sequence the Mail (Step 1)** – The software will generate address labels in order by postal codes, delivery mode codes and alphanumeric sequencing.
2. **Group the Mail (Step 2)** – This involves segregating the mail, including labelling for some groupings. This step prepares the mail for placing it in containers. Some software does this task.
3. **Place Groupings in Containers (Step 3)** – Proper facing will ensure efficient handling of the mailing.
4. **Label the Containers (Step 4)** – Correct labelling ensures that mail is directed to the appropriate work centre within a Canada Post facility and/or downstream destination.
5. **Make Up Monotainers and Pallets (Step 5)** – Monotainers and pallets make it much easier to move the mail and maintain the integrity of the presortation, ensuring efficient handling by Canada Post.
6. **Prepare the Mailing Summary (Step 6)** – If not completed properly, the deposit will be refused.

3 SEQUENCE THE MAIL (STEP 1)

The first step in presorting mail is called sequencing. Sequencing is the process of placing the mail in order to prepare for grouping the mail. The software should already sort the mail by NPS level:

- NPS Level 1 Urban
- NPS Level 1 Rural
- NPS Level 3 Distribution Centre Facility (DCF)
- NPS Level 4 Forward Consolidation Point (FCP)

NOTE : LCP mail is not grouped to NPS Level 2 City Consolidation.

For all levels of sortation, Canada Post prefers sequencing in ascending order (i.e., from lowest to highest numerically or alphabetically; as shown in Figure 12). The Customer can use descending order, provided it is used consistently for the entire mailing.

Figure 12:

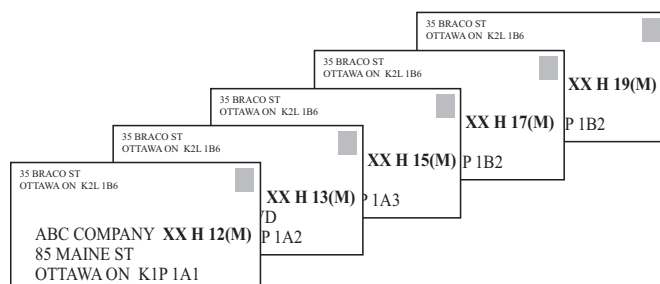

3.1 Sequencing Urban Mail (Level 1)

If the software has not already done so, sequence NPS Level 1 urban mail items by the following information:

1. Sort by Urban Delivery Facility in NPS order.
2. Within each Urban Delivery Facility, sequence in alphanumeric order by Delivery Mode Detail (DMD) (as shown in Figure 13).
3. Within each DMD, sequence in order by Forward Sortation Area (FSA) (as shown in Figure 13).
4. Within each FSA, sequence in alphanumeric order by Local Delivery Unit (LDU) (as shown in Figure 13) or by delivery address information (DAI) (as shown in Table 6). (Sequencing by DAI is an option, not a requirement.)

Figure 13: Examples of Sequencing

Table 6: Sequencing Urban Mail by Delivery Address Information

SEQUENCE ORDER		
Sequence by:	street name	in alphanumeric order
Then by	street type	in alphanumeric order
Then by	street direction	in alphanumeric order
Then by	civic number	group all odd numbers together in ascending alphanumeric order and then group all even numbers together
Then by	suite number	in alphanumeric order

3.2 Sequencing Rural Mail (Level 1)

If the software has not already done so, sequence NPS Level 1 Rural mail items by the following information (as shown in Figure 14):

NOTE : Rural mail is easily recognizable since the second character of the first segment (FSA) of the postal code is always zero (e.g., KOA, KOH).

1. Sort by Rural Delivery Facility in NPS order.
2. Within each Rural Delivery Facility, sequence items by all six characters of the postal code, in alphanumeric order.

Figure 14: Sequencing Rural Mail

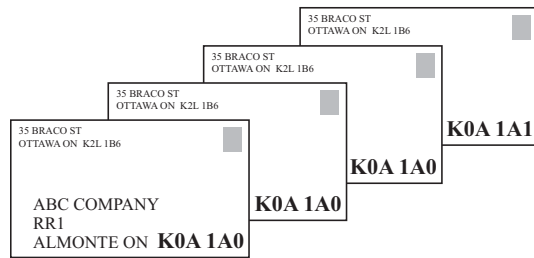

3.3 Sequencing Mail by DCF (Level 3)

DCF groupings typically consist of a combination of urban and rural mail. However, some major urban centres do not consolidate to a DCF (as shown in Table 7). These major urban areas consolidate to FCP (Level 4).

Table 7: Major Urban Centres That Do Not Consolidate to a DCF

MAJOR CENTRE NAME	
Calgary AB	Québec QC
Edmonton AB	Regina SK
Halifax NS (includes Dartmouth)	Saint John NB
Hamilton ON	Saskatoon SK
Kitchener ON	Toronto ON (and Greater Toronto area)
London ON	Vancouver BC
Montréal QC	Victoria BC
Moncton NB	Windsor ON
Ottawa ON	Winnipeg MB

Where DCF consolidation is permitted and the software has not already done so, sequence mail items by the following information (as shown in Figure 15):

1. Within each DCF, sort by Urban Delivery Facility (Level 1) in NPS order.
2. Within each Urban Delivery Facility, in NPS order for that DCF, then within each delivery facility, sort by Delivery Mode Detail (DMD), in alphanumeric order.
3. Within each DMD, sort by Forward Sortation Area (FSA), in alphanumeric order.
4. Within the FSA, sort by Local Delivery Unit (LDU), in alphanumeric order, or by delivery address information (DAI) (see also Table 6: “Sequencing Urban Mail by Delivery Address Information” on page 12).

5. Repeat 2–4 above for each Urban Delivery Facility.
6. After all Urban Delivery Facilities are sequenced, sequence by Rural Delivery Facility in NPS order.
7. Within each Rural Delivery Facility, sequence by all six characters of the postal code in alphanumeric order.

Figure 15:

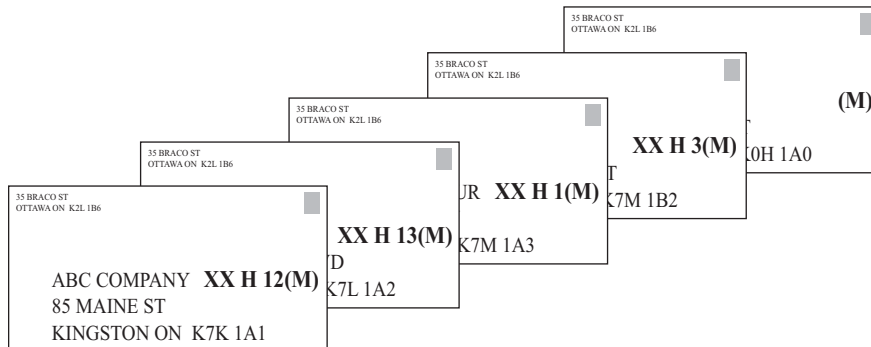

NOTE: Step 2 must be repeated for each Urban Delivery Facility within that DCF, in NPS order, before the sequencing of the Rural Delivery Facility.

3.4 Sequencing Mail by FCP (Level 4)

Where the software has not already done so, sequence mail by FCP (Level 4) by the following information (as shown in Figure 16):

1. Sequence each FCP in NPS order.
2. Within each FCP, sort by DCF (Level 3) in NPS order.
3. Within each DCF where DCF consolidation is permitted, sort by Urban Delivery Facility (Level 1) and Rural Delivery Facility in NPS order.
4. Within each Urban Delivery Facility, sort by Delivery Mode Detail (DMD) in alphanumeric order.
5. Within each DMD, sort by Forward Sortation Area (FSA) in alphanumeric order.
6. Within the FSA, sort by Local Delivery Unit (LDU) in alphanumeric order, or by delivery address information (see also Table 6: “Sequencing Urban Mail by Delivery Address Information” on page 12).
7. Repeat 4–6 above for each Urban Delivery Facility.
8. After all Urban Delivery Facilities are sequenced, sort by Rural Delivery Facility in NPS order.
9. Within each Rural Delivery Facility, sequence by all six characters of the postal code in alphanumeric order.
10. Repeat 1–9 above for each DCF within the FCP.
11. For major urban centres where DCF consolidation is not permitted, sort by Urban Delivery Facility (Level 1) in NPS order within the Forward Consolidation Point (FCP).
12. Within each Urban Delivery Facility, sort by Delivery Mode Detail (DMD), in alphanumeric order.

13. Within each DMD, sort by Forward Sortation Area (FSA), in alphanumeric order.
14. Within each FSA, sort by Local Delivery Unit (LDU), in alphanumeric order, or by delivery address information (see also Table 6: “Sequencing Urban Mail by Delivery Address Information” on page 12).
15. Repeat 12–14 above for each Urban Delivery Facility that does not consolidate to a DCF within the FCP.

Figure 16:

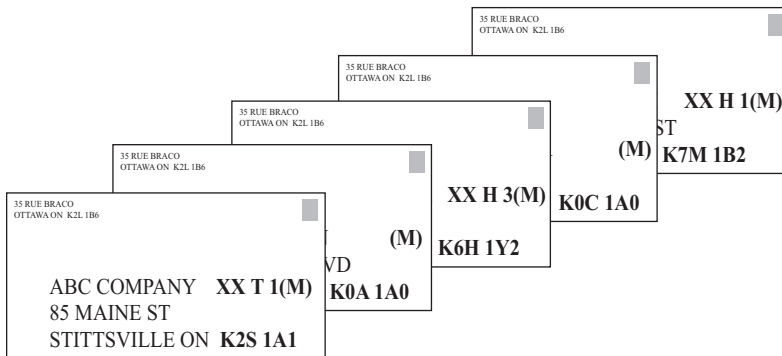

4 GROUP THE MAIL (STEP 2)

Grouping is the process of combining mail together by a common element. Some software does this step entirely.

NOTE 1: A minimum of 8 items is required for grouping Addressed Admail/Dimensional Addressed Admail.

2: A minimum of 6 items is required for grouping Publications Mail.

4.1 Grouping Elements

Key grouping elements for urban and rural mail are outlined in Table 8 (see also Figure 10).

Table 8: Grouping Elements

GROUPING ELEMENT	DESCRIPTION	GROUPINGS CONSIST OF...
Delivery Mode Detail (DMD)	DMD (up to a four-character code representing a particular Letter Carrier Walk identifier or other mode of delivery)	all urban addresses that fall under the same DMD
Urban Delivery Facility (Level 1)	Urban Delivery Facility	all DMDs within a single Urban Delivery Facility
Rural Delivery Facility (Level 1)	Rural Delivery Facility	all rural addresses (identified by a 0 in FSA) where the first five characters of the postal code are identical
Distribution Centre Facility (DCF) (Level 3)	level 3 is a combination of Urban Delivery Facilities (where DCF consolidation is permitted) and Rural Delivery Facilities	one or more Urban Delivery Facilities (where DCF consolidation is permitted) and/or Rural Delivery Facilities within the same DCF
Forward Consolidation Point (FCP) (Level 4)	level 4 is a combination of DCF and/ or Urban Delivery Facilities that do not consolidate to a DCF	one or more DCFs within the same FCP and/or one or more Urban Delivery Facilities that do not consolidate to a DCF within the same FCP
Residue	not applicable	any combination of the above, but must be sequenced according to the NPS. <i>Addressed Admail and Publications Mail items that are non-qualified/uncoded must be bundled and may be included with Residue mail. The Residue price will apply to each item.</i>

4.2 Grouping Urban Mail (Level 1)

For Urban mail (Level 1), group mail by Delivery Mode Detail (DMD) when there are enough items to make up a grouping. When there are not enough items in a DMD for a grouping, create a mixed grouping of items by Urban Delivery Facility (as shown in Figure 17). Groupings of two or more Delivery Mode Codes (DMCs) are often referred to as “XX groupings” because the software places an XX in front of the DMD (see section 2.2.2 “Delivery Mode Details” on page 5 for more information), when two or more DMCs are combined in a grouping. The two Xs indicate to the Letter Carrier that it is a mixed grouping, that is, that the grouping should be further sorted since it is not destined for a single DMC.

Figure 17: Grouping Urban Mail

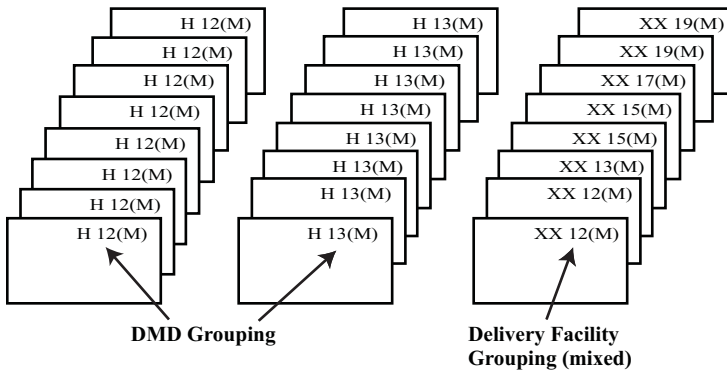

In rural areas, by Rural Delivery Facility (first five characters of the postal code).

4.3 Grouping Rural Mail (Level 1)

For Rural mail (Level 1), group mail by Rural Delivery Facility. In the example shown in Figure 18, the first five characters of the postal code represent a Rural Delivery Facility; the sixth character identifies service codes with the facility.

Figure 18: Grouping Rural Mail

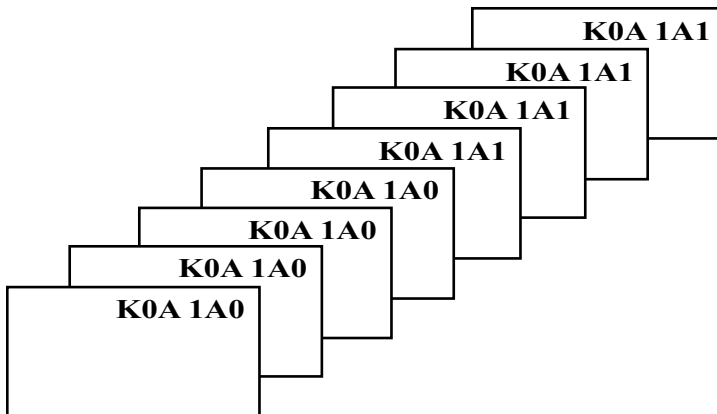

4.4 Grouping Mail for DCF (Level 3)

DCF groupings typically consist of a combination of urban and rural mail. However, some major urban centres do not consolidate to a DCF (see also Table 7: “Major Urban Centres That Do Not Consolidate to a DCF” on page 13).

Group mail for DCF (Level 3) as indicated by the NPS. For example, Figure 19 shows a grouping of FSAs beginning with K8N, K8P and K8R, for DCF Belleville.

Figure 19:

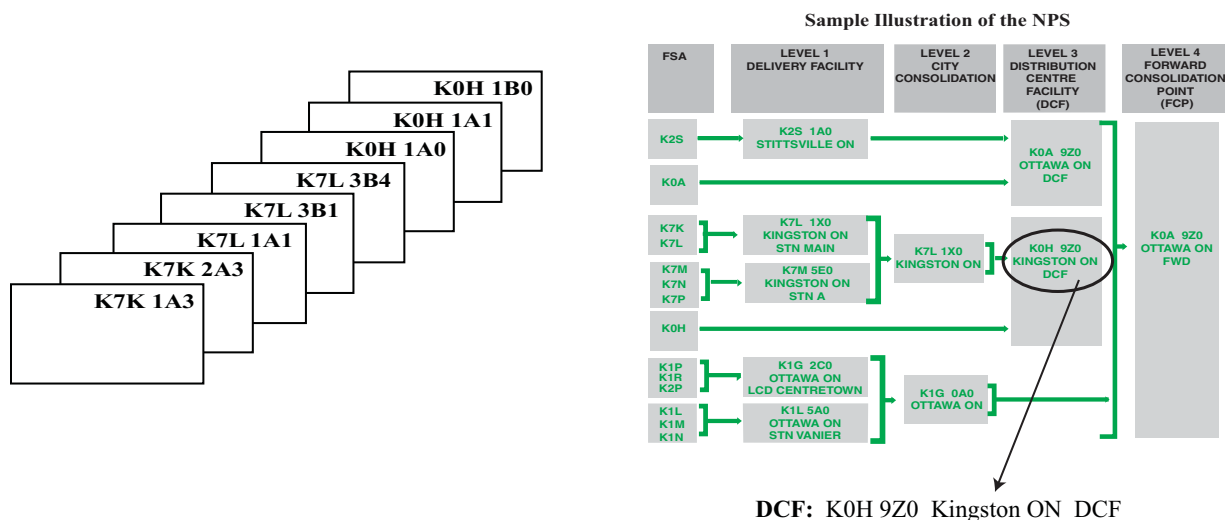

NOTE : This example is for illustration purposes only and may not reflect the current NPS.

If the Customer does not have the minimum number of items required for a DMD grouping or an Urban Delivery Facility grouping, the urban mail may be combined with rural mail within the same DCF (Level 3), as indicated by the NPS, to create a DCF grouping.

Figure 20 shows how urban and rural mail can be combined for a DCF grouping.

Figure 20:

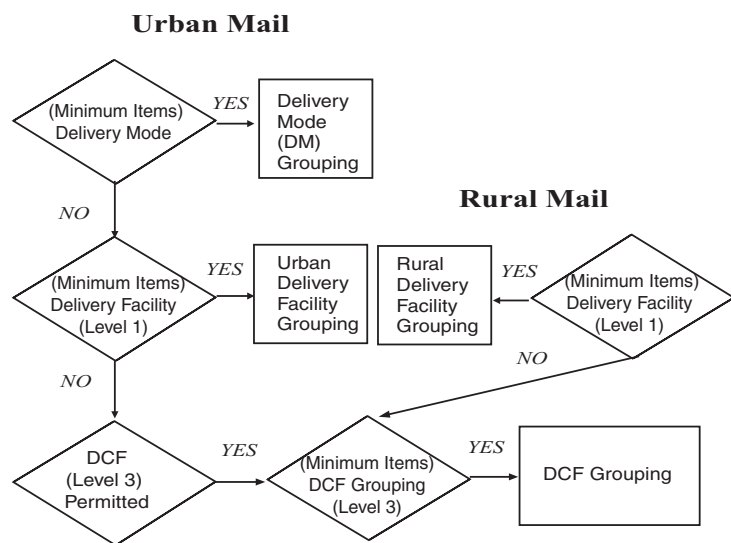

If the Customer does not have the minimum number of items required for a DCF grouping, create an FCP grouping as described below.

If there are not enough items for a grouping at Level 1 (DMD grouping or Delivery Facility grouping) for major urban centres where DCF consolidation is not permitted, consolidate at FCP (Level 4).

4.5 Grouping Mail for FCP (Level 4)

FCP (Level 4) groupings typically consist of a combination of mail destined for major urban centres where DCF consolidation is not permitted and mail destined for Distribution Centre Facilities (DCFs) within the same FCP for which there are not enough items per DCF. Figure 21 shows how mail can be combined for an FCP grouping.

Figure 21:

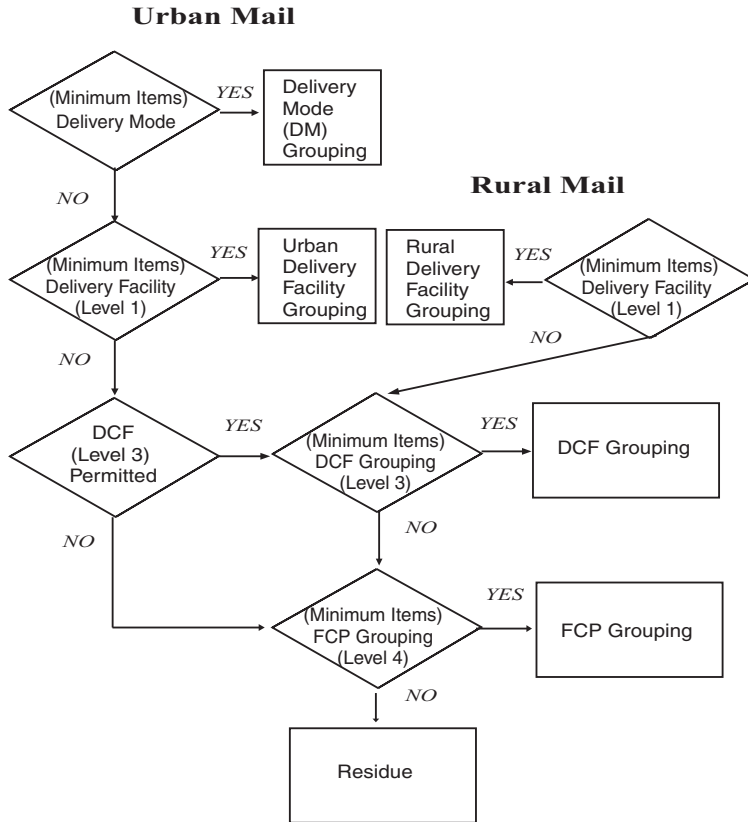

NOTE: The items within the DCF, FCP and Residue groupings are to be sequenced by NPS order.

Group mail for FCP as indicated by the NPS (as shown in Figure 22).

Figure 22:

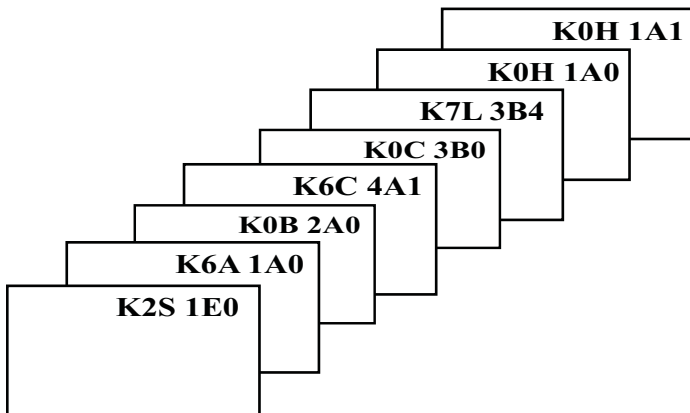

4.6 Grouping Mail for Residue

Residue mail is mail that the Customer cannot make up in accordance with the NPS because there is not enough mail volume to qualify to consolidate to an NPS level. Label Residue mail to go to the originating Office of Deposit, which will work on the items.

If the Customer does not have the minimum number of items required for an FCP grouping, then a Residue grouping is to be created. The Residue grouping has no minimum number of items. All items must be facing the same way with the address visible on the top side of the grouping.

Addressed Admail and Publications Mail items that are non-qualified/uncoded must be bundled and may be included with Residue mail. The Residue price will apply to each item.

Group mail for Residue as indicated by the NPS (as shown in Figure 23).

Figure 23:

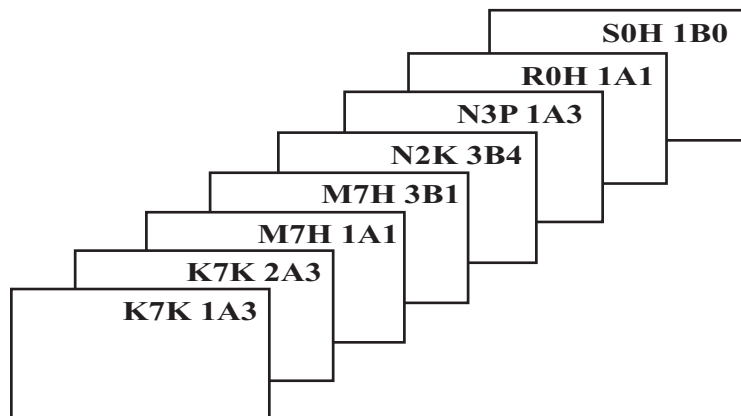

4.7 Segregating Groupings

Groupings must be prepared so as to maintain the integrity of the mail presortation during handling. They are placed within containers (that is, hardsided containers or bags) and are segregated by one of the following methods:

- separator cards or edgemarking for hardsided containers only; or
- bundling (includes shrink-wrapping) for bags, as well as for hardsided containers.

When using separator cards or edgemarking to segregate groupings, there is no maximum number of items per grouping. For example, if the Customer has 100 items for one grouping, only one edgemark or separator card is permitted to identify the start of the grouping while still grouping items. (When placing groupings in containers, if a grouping is too large to fit in one container, a second separator card at the beginning of the second container is needed. Additional edgemarking is not therefore applied.)

Maximum thickness for bundles is listed in Table 9: "Bundling Specifications" on page 22.

DCF, FCP and Residue groupings must be identified for each grouping:

- identify the groupings on the separator card – this needs to be visible on the part of the card that shows above mail items;
- if using edgemarking, apply the edgemarks to only the first envelope in each grouping; and
- identify groupings on bundle labels (formerly called facing slips).

4.7.1 SEPARATOR CARDS

Separator cards are used to indicate a break between groupings (as shown in Figure 24) and are made of thin, rigid cardboard (a weight of 120 to 160 grams per square metre is normally adequate), and can be any colour.

Figure 24: Separator Cards

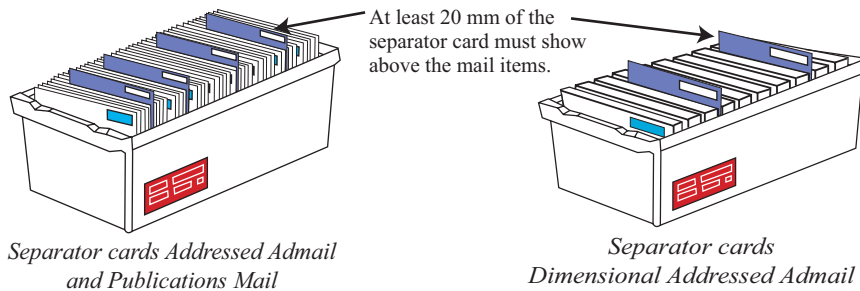

Separator cards must also:

- extend at least 20 mm above the top of the mail;
- be at least 155 mm wide (1/2 the width of the container) to minimize the likelihood of the card tipping (as shown in Figure 25);
- be placed in front of the first mail item in each grouping; and
- be big enough and heavy enough card stock to prevent them from sliding under the level of the mail or tipping sideways.

Figure 25: Separator Card Dimensions

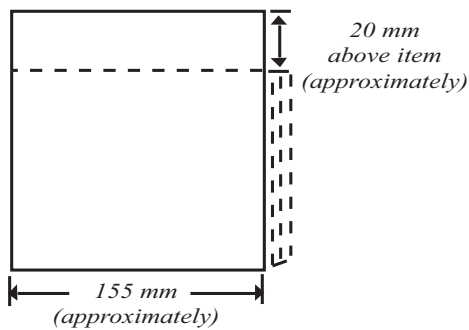

The Customer may use other types of separators (for example, the re-use of card stock that is no longer needed for its original purpose, such as advertising) with prior Canada Post approval.

4.7.2 EDGEMARKING

Edgemarking refers to the use of ink or paint applied to the top edge of a mail item (envelope or box) to indicate a break between groupings within a hardsided container. The same colour is used for the entire mailing. Some software performs this task. Edgemarks are applied only to the first item at the beginning of each grouping (as shown in Figure 26).

Figure 26: Edgemarking

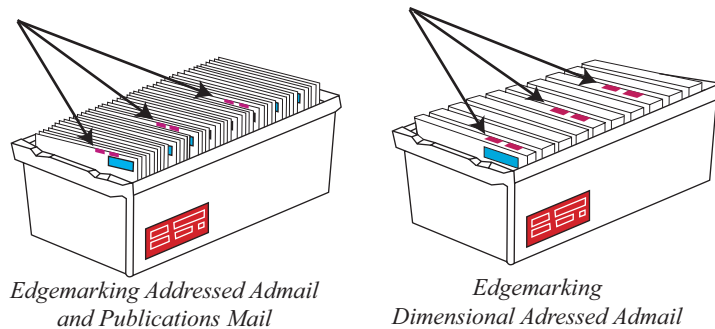

If the Customer uses edgemarking:

- the colour of edgemarks must significantly contrast with the colour of the mail items
- edgemarks must begin approximately 40 mm from the right, upper edge of the mail item
- the first marking indicates a DMD grouping and is approximately 20 mm long
- the second edgemarking indicates a Delivery Facility grouping and is approximately 20 mm long (as shown in Figure 27)
- there is a gap of approximately 25 mm between the DMC mark and the Delivery Facility mark.

Figure 27 shows the preferred method for edgemarking, in which both the DMC mark and the Delivery Facility mark are included. Canada Post will accept a single mark, which can identify either DMC or Delivery Facility, but any type of single mark must be in the location indicated for DMC.

Figure 27: Edgemarking Dimensions

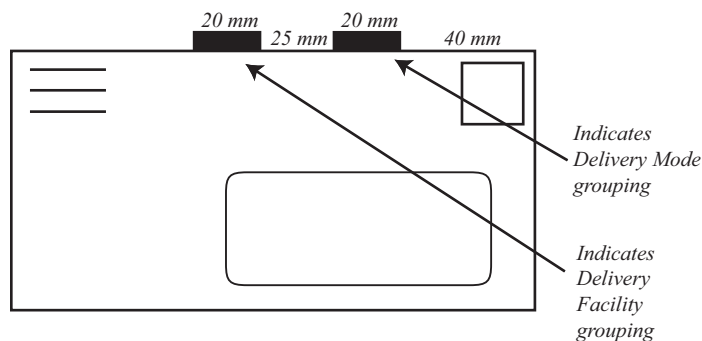

Edgemarking to identify the end of the container for the Customers own operational use is acceptable, but should not be placed in either of the locations reserved for the DMC or Delivery Facility.

4.7.3 BUNDLING

A “bundle” describes a number of mail items secured together by strapping (using elastic bands, string or plastic straps) or by shrink-wrapping. The maximum thickness of a bundle is shown in Table 9.

Table 9: Bundling Specifications

MAXIMUM THICKNESS	MINIMUM NUMBER OF ITEMS*
100 mm (4 inches) for S/L AA/Publications Mail and Small and Medium DAA	6 for Publications Mail 8 for Addressed Admail and Dimensional Addressed Admail
200 mm (8 inches) for O/S AA/Publications Mail and Large DAA	6 for Publications Mail 8 for Addressed Admail and Dimensional Addressed Admail

* The maximum thickness takes precedence over the minimum number of items. The last Residue bundle has no minimum number of items, although it still must follow the specifications for maximum thickness per bundle or grouping.

When a bundle exceeds the maximum thickness and there are sufficient items to create a full second bundle, it is preferable to split the total number of items into two equal bundles, rather than create one full bundle and one very small bundle. For example, if the Customer has an S/L bundle of 52 items with a thickness of 125 mm, make two bundles of 26 items.

If a bundle exceeds the maximum thickness, and there are insufficient items to create a full second bundle, it is acceptable to split the bundle, resulting in fewer than the minimum number of items in the second bundle. For example, if the Customer has an O/S bundle of 11 items with a thickness of 250 mm, split the bundle into two (2) bundles, one containing six (6) items and the other containing five.

4.7.3.1 Single-Strapping (Hardsided Containers)

NOTE : Strapping must be strong and tight enough to hold the bundle together when held vertically, without the contents sliding.

Single-strapping (as shown on the left in Figure 28) is sufficient for the following types of mail to be placed in hardsided containers:

- Short/Long (S/L) AA/Publications Mail;
- Small/Medium DAA; and
- Oversize (O/S) AA/Publications Mail and Large DAA bundles grouped for Level 1 of the NPS only

Figure 28: Example of Single-Strapping

Hardsided Containers

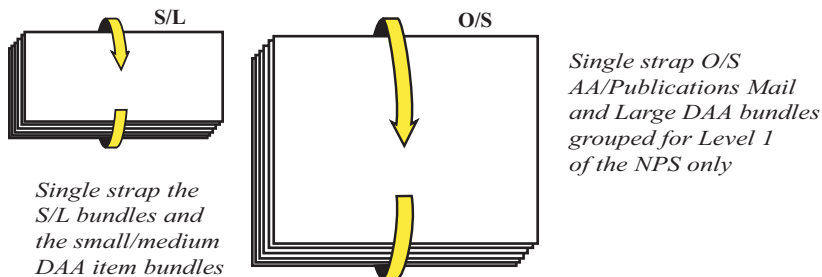

4.7.3.2 Double-Strapping (Bags and Hardsided Containers)

NOTE : DAA mail items are not permitted in bags.

Double-strapping must be used for all items to be placed in bags and for O/S items in hardsided containers as listed below (as shown in Figure 29):

- Short/Long (S/L) AA/Publications Mail (bags);
- Oversize (O/S) AA/Publications Mail (bags); and
- Oversize (O/S) AA/Publications Mail and Large DAA (hardsided containers).

Figure 29: Example of Double-Strapping

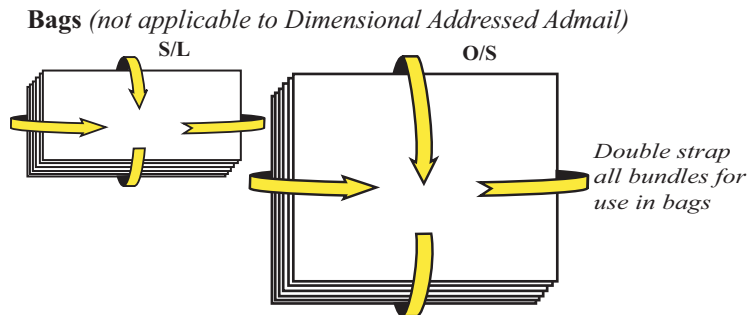

4.7.3.3 Shrink-wrapping

Shrink-wrapping is an acceptable method of bundling O/S items of AA/Publications Mail and Large DAA items. The plastic used for the shrink-wrapping must be strong enough to ensure the bundle remains secured during handling.

4.7.3.4 Uneven Spines

A bundle with publications whose spines make the mail pile uneven may be split into two, so that the bottom half has the spines facing one way and the top half has the spines facing the other way to create a level bundle (as shown in Figure 30). All destination addresses and postal indicia must still face in the same direction.

Figure 30: Bundling Uneven Spines

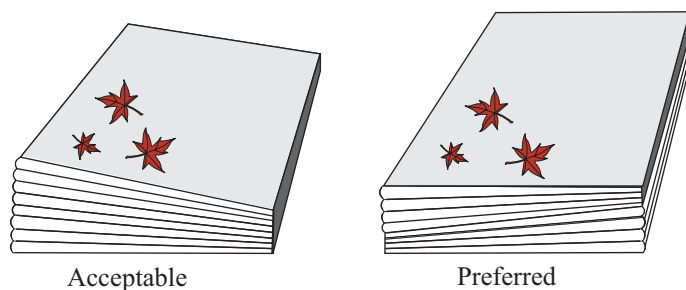

4.7.4 LABELLING BUNDLES

Table 10 describes when bundles must be labelled. When bundling, Customers must use a bundle label (also called a facing slip) to identify DCF (Level 3), FCP (Level 4) and Residue groupings.

Table 10: Labelling Bundles

NPS LEVEL	GROUPING	LABEL REQUIRED
Not Applicable	Delivery Mode Detail (DMD)	No
Level 1	Urban Delivery Facility	No
Level 1	Rural Delivery Facility	No
Level 3	Distribution Centre Facility (DCF)	Yes
Level 4	Forward Consolidation Point (FCP)	Yes
Not Applicable	Residue	Yes

4.7.4.1 Bundle Label Specifications

Bundle labels must be 86 mm high by 95 mm wide. They must be white and securely fastened to the bundle. For shrink-wrapped bundles, labels can be placed, but not glued, on or under the plastic film; however, the label contents must remain clearly visible.

4.7.4.2 Labels for Distribution Centre Facility (DCF) Bundles

For DCF bundles, the label must include the following routing information:

- postal code of the DCF, as per the NPS, e.g., K0A 9Z0;
- name of the DCF, e.g., OTTAWA ON DCF; and
- service option, i.e., LCP.

Additional information, such as which bag or which bundle, is permitted above or below the routing information. However, the routing information must be predominant. Figure 31 shows a sample bundle label for a DCF grouping.

Figure 31:

DCF Bundle Label

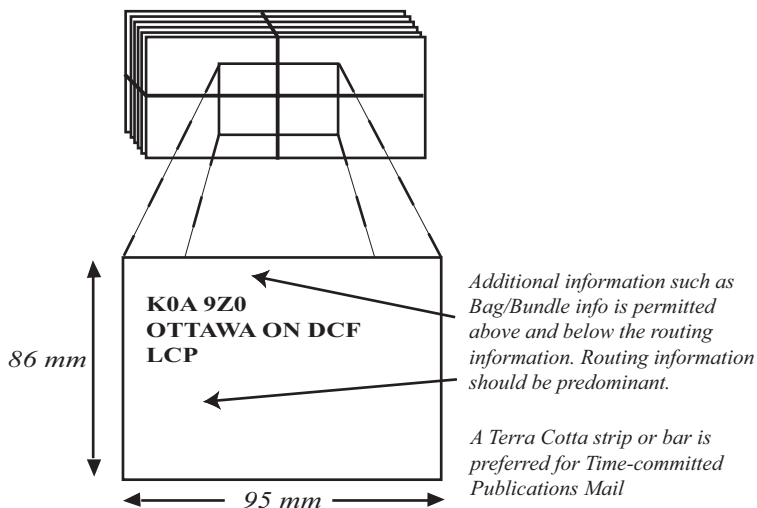

4.7.4.3 Labels for Forward Consolidation Point (FCP) (Level 4) Bundles

For FCP groupings, the label must include the following routing information:

- postal code of the FCP, e.g., K0A 9Z0;
- name of FCP, e.g., OTTAWA ON FWD; and
- service option, e.g., LCP.

Additional information, such as bag/bundle information, is permitted above or below the routing information. However, the routing information must be predominant. Figure 32 shows a sample label for an FCP grouping.

Figure 32:

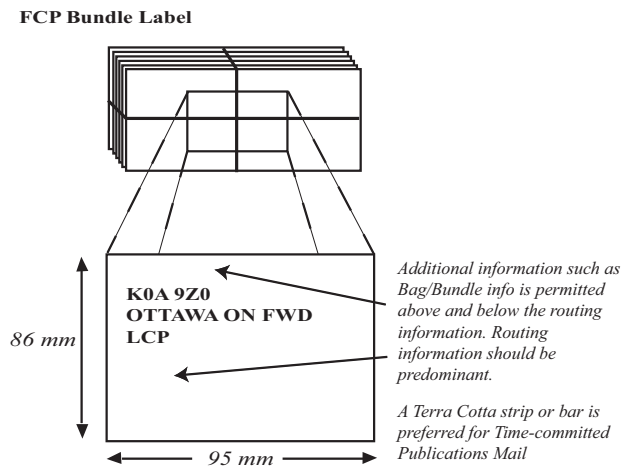

4.7.5 LABELLING RESIDUE GROUPINGS

Labels for Residue groupings cannot show a postal code. Instead, the label must include the following routing information:

- name of the Office of Deposit with the forward abbreviation FWD, e.g., OTTAWA ON FWD;
- the word Residue; and
- the service option, e.g., LCP.

Additional information, such as bag/bundle information, is permitted above or below the routing information. However, the routing information must be predominant.

Figure 33 shows a sample bundle label for a Residue grouping.

Figure 33:

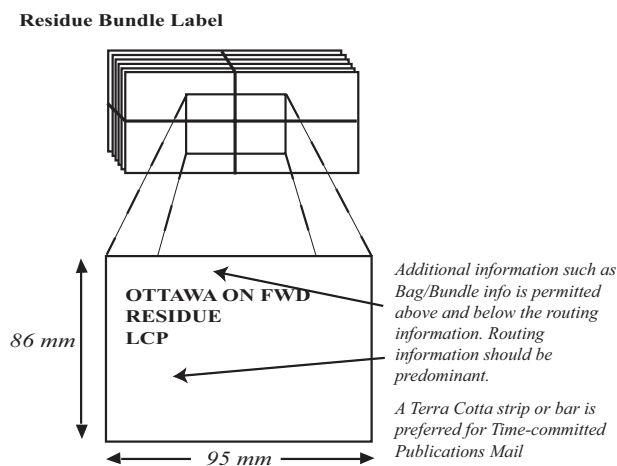

5 PLACE GROUPINGS IN CONTAINERS (STEP 3)

Canada Post accepts four types of containers, including two types of hardsided containers and two types of bags, as described below. The same type of container must be used for the entire deposit.

NOTE : Customers cannot use bags for Dimensional Addressed Admail.

5.1 Hardsided Containers

There are two basic types of hardsided containers: lettertainers and flats tubs:

Lettertainers (as shown in Figure 34) are used for:

- Short and Long (S/L)
- Publications Mail
- Addressed Admail
- Small and Medium Dimensional Addressed Admail

Flats tubs (as shown in Figure 35) are used for:

- Oversize (O/S)
- Publications Mail
- Addressed Admail
- Large Dimensional Addressed Admail.

NOTE : Other hardsided containers may be used with prior approval from Canada Post.

Figure 34: Lettertainer

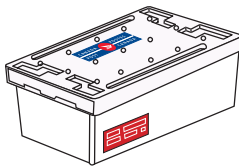

Lettertainer

Figure 35: Flats Tub

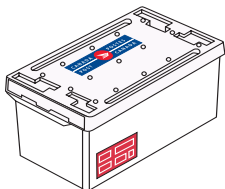

Flats Tub

The maximum weight of a hardsided container and its contents cannot exceed 25 kg. All containers must be deposited with lids unless other local arrangements have been made with a Canada Post Representative. Table 11 lists the specifications for hardsided containers.

Table 11: Hardsided Container Specifications

TYPE OF CONTAINER	WEIGHT	LENGTH	WIDTH	HEIGHT	MAX WEIGHT (INCLUDING CONTAINER)
Lettertainer	1.8 kg	535 mm	251 mm	156 mm	25 kg
Flats Tub	1.7 kg	405 mm	240 mm	303 mm	25 kg

Face all bundles in hardsided containers in the same direction (as shown in Figure 36).

Figure 36:

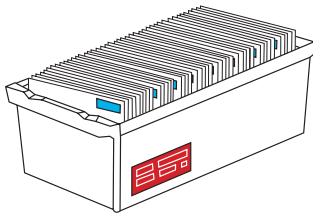

To maximize the use of space for uneven bundles, the preferred method is to alternate the spines within each bundle. However, it is acceptable to place the mail so that all the spines rest on the bottom of the container or at the top (as shown in Figure 37).

Figure 37:

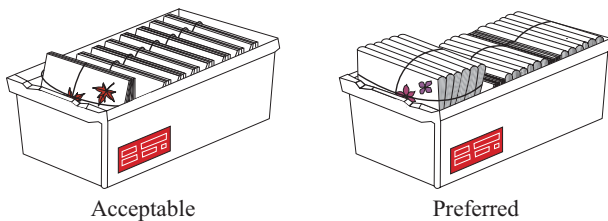

Mail can be placed lengthwise in the container (as shown in Figure 38), only when none of the other options can be used.

Figure 38:

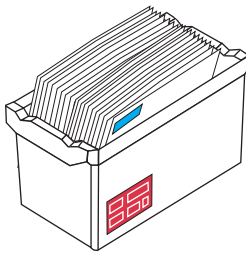

5.1.1 HARSDSIDED CONTAINER FILL REQUIREMENTS

All containers should be full (as shown in Figure 39). While the ideal is that all containers be 100% full, the minimum acceptable is 70%. A container is considered full when:

- the contents and the container weigh 25 kg. This maximum weight must not be exceeded, even if it is necessary to reduce the number of items in the container.
- its contents, when the container is tipped on its short end at a 45–90° angle, are compressed by their own weight to fill at least 70% of the container's length. This holds true even when only one container is going to a destination. If such a container contains less than 70%, consolidate that mail to the next level.

Figure 39: Full Container

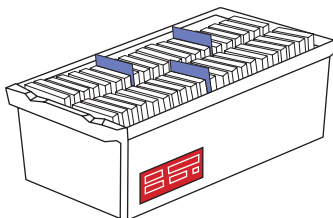

*Example of a full container
showing items placed
side by side*

There is no minimum fill requirement when there is only one Residue container.

5.1.2 DEALING WITH LEFTOVER MAIL ITEMS FOR HARSDIDED CONTAINERS

After the Customer has filled as many hardsided containers as possible to the same destination and still have mail items to that destination left over, the Customer may prepare one less-than-full container for that destination. The less-than-full container has no minimum fill requirement, but the Customer must keep the mail in its presorted order by strapping or bundling the mail items. The Customer may use single strapping for O/S bundles in hand-sided containers accessing Level 1 of the NPS. For all other types of mail, use double strapping (as shown in Figure 40).

Figure 40: Less-Than-Full

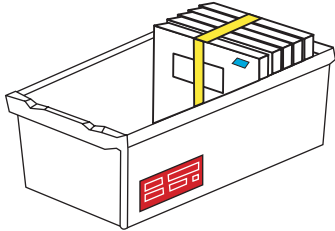

*Less than full container,
strapped to maintain
sort integrity*

Here are some guidelines for dealing with leftover mail items that cannot fill a container:

- **Urban consolidation applies to those Urban Delivery Facilities with no DCF (Level 3) consolidation** – Where there is sufficient volume to fill at least one container for an Urban Delivery Facility, prepare a container for that Facility. If not, where there is sufficient volume to fill at least one container at the City Level (Level 2), prepare a City container. If there is less than one container at the City Level, prepare an FCP container. If there is less than one container of FCP, place the mail in a Residue container. (The last Residue container has no minimum number of groupings.)
- **Urban consolidation applies to those Delivery Facilities with DCF (Level 3) consolidation** – For urban mail, where there are sufficient groupings to fill at least one container for an Urban Delivery Facility, prepare a container for that facility. If not, where there are sufficient groupings to fill at least one container at the City Level (Level 2), prepare a City container. If not, the urban groupings, the rural groupings and the DCF groupings (Level 3), can be combined to create a DCF container. If not, where there are sufficient urban and rural groupings, DCF groupings within the same FCP and groupings within that FCP (Level 4), combine the groupings to prepare an FCP container. If there is less than one container for the FCP, place this mail in the Residue container.
- When the Customer cannot fit the last bundle into a container, and without the last bundle the container would be less than 95% full, the Customer may break the bundle, ensuring that the minimum number of items is in the next container. If the minimum bundle requirement cannot be met, the Customer may move the whole bundle into the next container and leave the other container at less than 95% full.
- When using edgemarking or separator cards to group items, if the Customer cannot fit the items for the last grouping into the container, place the remaining items from the grouping into the next container. If this results in placing fewer than the minimum number of items of that grouping into the container, that is acceptable.

5.2 Bags

There are two types of bags:

- **Large bags (A-3)** are used for Short and Long (S/L) and Oversize (O/S) Publications Mail and Addressed Admail (as shown in Figure 41). A large bag must contain at least 6 bundles or weigh at least 7 kg.
- **Small bags (A-6)** are used for Short and Long (S/L) and Oversize (O/S) Publications Mail and Addressed Admail (as shown in Figure 41). A small bag must contain at least 4 bundles or weigh at least 3.5 kg.

If the Customer is using bags, the entire mailing must be in the same-sized bags.

Figure 41: Types of Bags

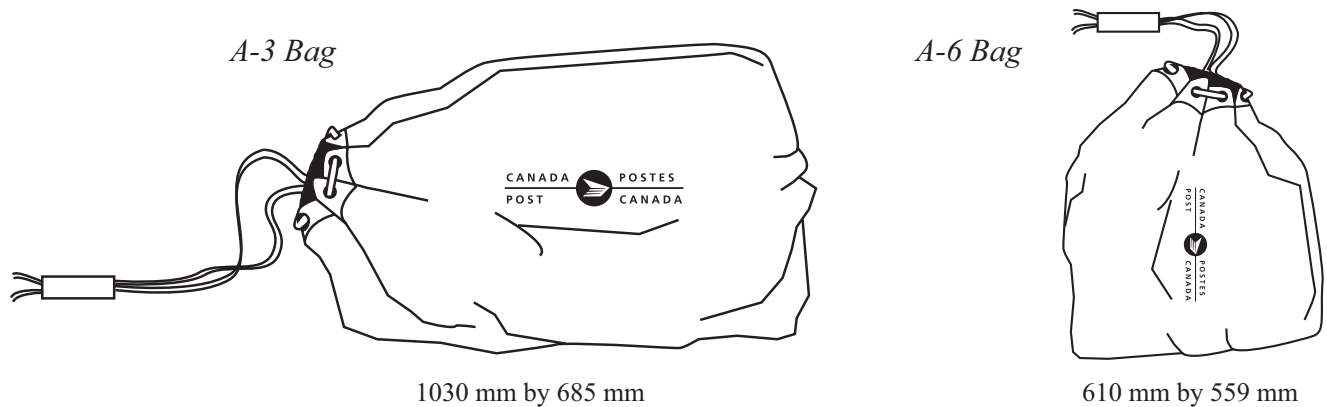

The maximum weight of a bag (including the bag) cannot exceed 25 kg. The Customer cannot use bags for Dimensional Addressed Admail. Table 12 lists the specifications for bags.

Table 12: Bag Specifications

TYPE OF BAG	WEIGHT	LENGTH	WIDTH	MAX WEIGHT (INCLUDING BAG)	MINIMUM NUMBER OF BUNDLES/WEIGHT
Large bag (A-3)	1 kg	1030 mm	685 mm	25 kg	6 bundles or 7 kg
Small bag (A-6)	0.5 kg	610 mm	559 mm	25 kg	4 bundles or 3.5 kg

NOTE : If the Customer does not have the minimum required to fill a bag, consolidate the mail to the next level. If the Customer does not have the six (6) bundles or 7 kg required to fill a large bag or the four (4) bundles or 3.5 kg needed to fill a small bag, consolidate the mail to the next level. However, the Customer cannot consolidate to the next level mail that qualifies for containerization at Level 1. For example, if the Customer has 22 bundles for a Delivery Facility and has placed a maximum of 20 bundles weighing 25 kg in one bag, all 22 bundles must be containerized to the Delivery Facility. The two remaining bundles cannot be consolidated to the next level. In this instance, the Customer would put the two bundles in another bag for DF (Level 1), but only because the Customer already has at least one full container to the Delivery Facility.

5.3 Levels of Containerization

When placing groupings in containers, the Customer needs to consider how the Customer has sorted them and how much mail the Customer needs to fill a container for a type of delivery facility (see section 5.3.1 “Rules for Consolidating Mail in Containers” on page 31 for more information). Also, if a grouping is too large to fit in one container, the Customer would need to prepare and insert a second separator card at the beginning of the second container for that grouping.

Table 13: “Elements for Consolidating Mail in Containers” on page 30 lists how to use groupings to consolidate mail in containers and Figure 42 shows the steps for deciding when to consolidate to the next level (see also Figure 11).

Table 13: Elements for Consolidating Mail in Containers

CONSOLIDATION ELEMENT	CONTAINERS CONSIST OF GROUPINGS FOR..
Urban Delivery Facility (Level 1)	Delivery Mode Code (DMC) and Urban Delivery Facility
Rural Delivery Facility (Level 1)	Rural Delivery Facility
City Consolidation (Level 2)	DMC and Urban Delivery Facility in the same city when there are not enough mail items to fill at least one container for Urban Delivery Facility
Distribution Centre Facility (DCF) (Level 3), where permitted	DMC, Urban Delivery Facility and Rural Delivery Facility in the same DCF that could not fill a container for Level 1 or Level 2
Forward Consolidation Point (FCP) (Level 4)	DMC, Urban Delivery Facility, Rural Delivery Facility and DCF in the same FCP and/or one or more Urban Delivery Facilities that do not consolidate to a DCF within the same FCP that could not fill a container for Level 1, Level 2 or Level 3
Residue	Any combination of items that could not fill a container for Level 1, Level 2, Level 3 or Level 4

Figure 42:

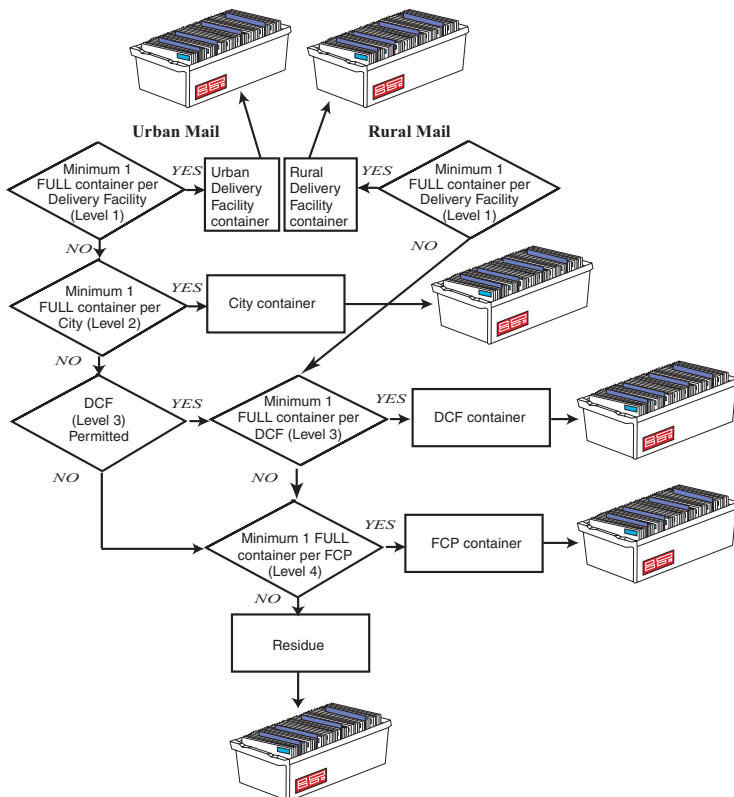

5.3.1 RULES FOR CONSOLIDATING MAIL IN CONTAINERS

- consolidate to the lowest grouping/container possible
- if there are sufficient groupings to fill at least one container for a Delivery Facility (Level 1), create a container for that facility **maintaining NPS order**
- if there are sufficient groupings to fill at least one container for City (Level 2), create a City container **maintaining NPS order**
- in the major urban area where DCF (Level 3) consolidation is not permitted; if the Customer is unable to create a Delivery Facility (Level 1) or a City container (Level 2), create a FCP container (Level 4) **maintaining NPS order**
- where DCF (Level 3) consolidation is permitted and if the Customer is unable to fill at least one container to a Delivery Facility (Level 1), or one container to a City (Level 2), create a DCF (Level 3) container with the urban, rural and DCF groupings **maintaining NPS order**
- if the Customer does not have sufficient groupings to meet the minimum fill requirement of a DCF (Level 3) container, create an FCP (Level 4) container **maintaining NPS order**
- if the Customer does not have sufficient groupings to meet the minimum fill requirement of a FCP (Level 4) container, create a Residue container **maintaining NPS order**.

5.4 Sequencing Groupings within Hardsided Containers

It is important to maintain the integrity of the presort when the Customer places their mailing in containers. Here are some rules for placing groupings in hardsided containers (sequencing is not required when bags are used.):

1. Consider first whether the Customer has enough mail for a single Urban Delivery Facility or single Rural Delivery Facility (both Level 1) to fill at least one container. If not, consolidate the mail to the Level 2, City Consolidation, and determine whether they have enough for at least one container. If not, consolidate to a DCF, where permitted. If none of these options are viable, consolidate to Level 4, FCP. For Residue, see section 5.4.1 “Residue Containers” on page 32.
2. Maintain **NPS** order as the Customer places the mail in containers.
3. Face all mail in the same direction.
4. Use any edge markings or divider cards the Customer prepared for the groupings.
5. If the Customer has two rows of mail in the same container, have the first row start on the left moving from front to back and the second row start where the first row left off, also moving from front to back (as shown in Figure 43).

Figure 43:

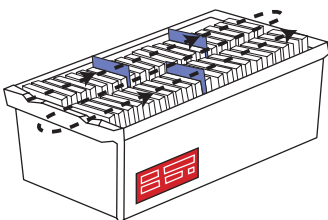

5.4.1 RESIDUE CONTAINERS

For mail that cannot fit in containers consolidated to the four NPS levels, prepare a Residue container (as shown in Figure 44) and sequence the mail as follows:

1. If there is only one Residue grouping, place it in NPS order in its own container.
2. Sequence by Forward Consolidation Point (FCP) (Level 4) in NPS order.
3. Then, within each Forward Consolidation Point (FCP), sequence by Distribution Centre Facility (DCF) (Level 3) in NPS order.
4. Then, within each Distribution Centre Facility (DCF), sequence by Urban Delivery Facility (Level 1) where DCF consolidation is permitted in NPS order.
5. Within each Urban Delivery Facility, sequence by DMD in alphanumeric order.
6. Then, sequence by Delivery Facility groupings in NPS order.
7. Repeat this step for each Urban Delivery Facility within a DCF.
8. Then, sequence by Rural Delivery Facility, by postal code in alphanumeric order.
9. Then, sequence by DCF grouping (Level 3) in NPS order.
10. Repeat Steps 2 through 5 above for each DCF within a FCP, in NPS order.
11. Then, sequence by City where DCF consolidation is not permitted in NPS order.
12. Within each Delivery Facility, sequence by DMD in alphanumeric order.
13. Then, sequence by Delivery Facility groupings in NPS order.
14. Repeat this step for each Urban Delivery Facility that does not consolidate to a DCF within an FCP, in NPS order.
15. Then, sequence by FCP (Level 4) groupings in NPS order.
16. Repeat Steps 2 through 8 for each FCP, in NPS order.
17. Then sequence by Residue grouping in NPS order.

Figure 44:

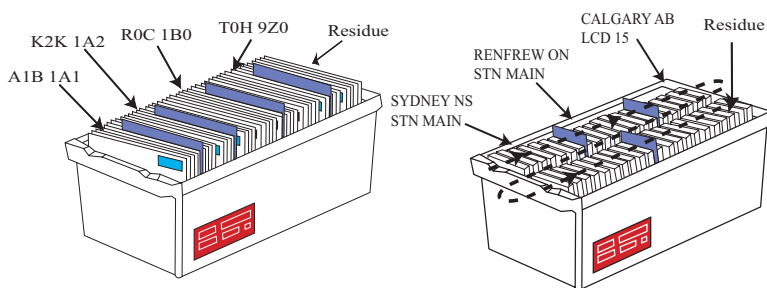

Example of Residue containers

6 LABEL THE CONTAINERS (STEP 4)

All containers must be labelled to their destination using routing information determined from the National Presortation Schematic (NPS). Correct labelling of containers ensures that mail is directed to the appropriate work centre (e.g., City, FWD) within a Canada Post facility.

6.1 Labels/Tags, Service and Routing Information

Container labels and bag tags must be bilingual and include the following information (as shown in Figure 45):

- service name (Addressed Admail, Dimensional Addressed Admail or Publications Mail);
- service option (e.g., LCP);
- NPS routing information (see section 6.1.2 “Labelling Residue Containers” on page 36) as follows:
 - facility postal code,
 - facility name (e.g., OTTAWA), province abbreviation (e.g., ON, MB, SK), and
 - routing designation (e.g., STN Vanier, LCD Centretown).

Figure 45:

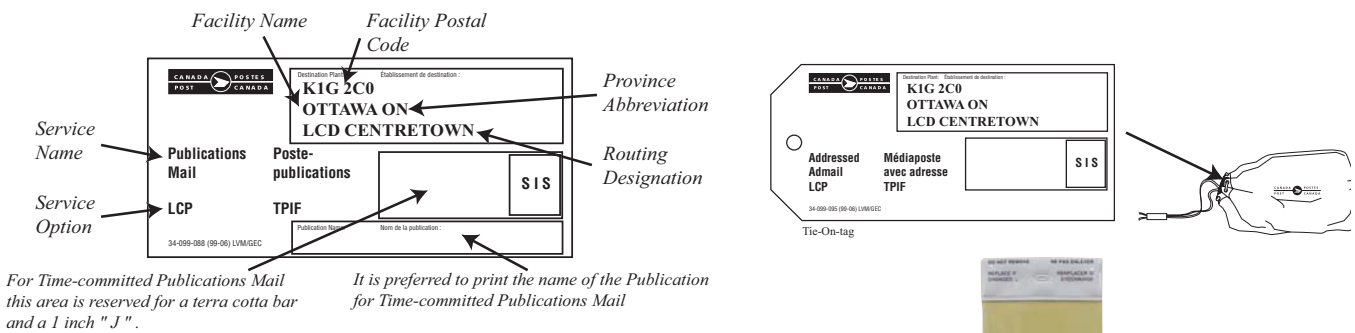

This label can be used for Bags also, if vinyl label holder option is used

6.1.1 NPS ROUTING INFORMATION

Figure 46, Figure 47, Figure 48, Figure 49, and Figure 50 show examples of how to determine routing information from the National Presentation Schematic (NPS).

Figure 46:

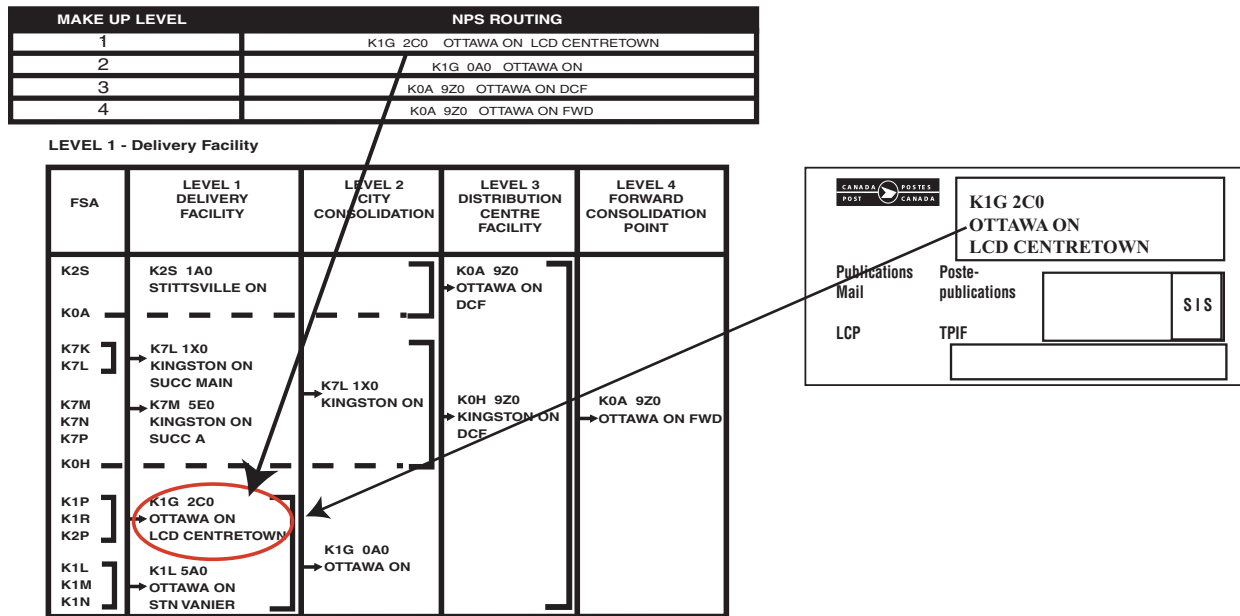

Figure 47:

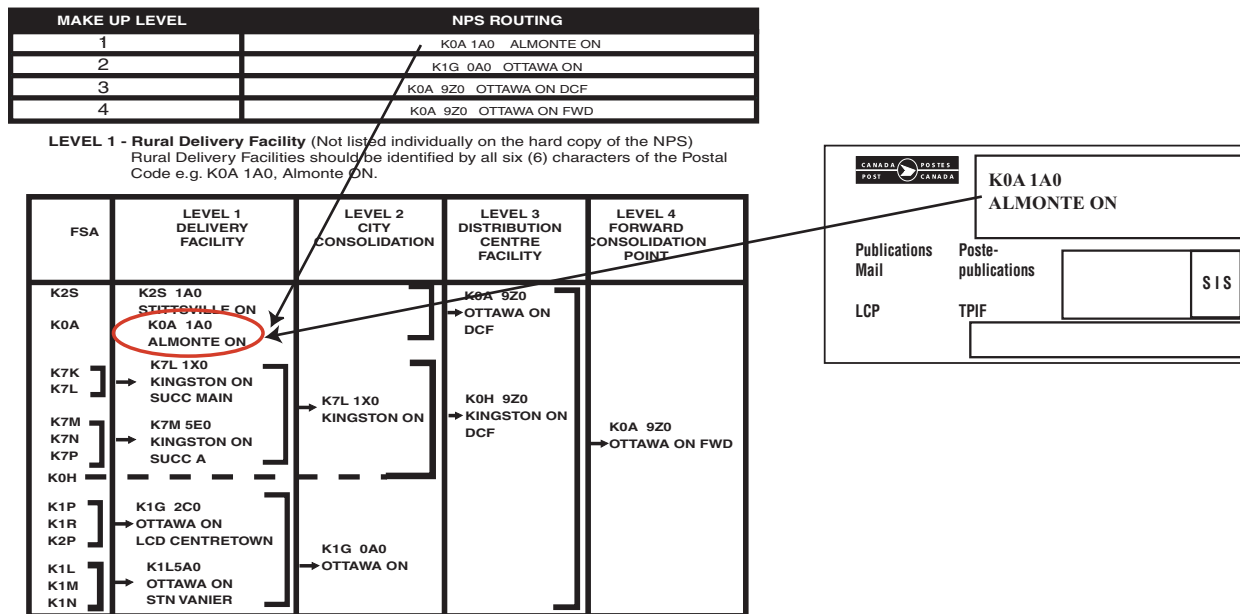

Figure 48:

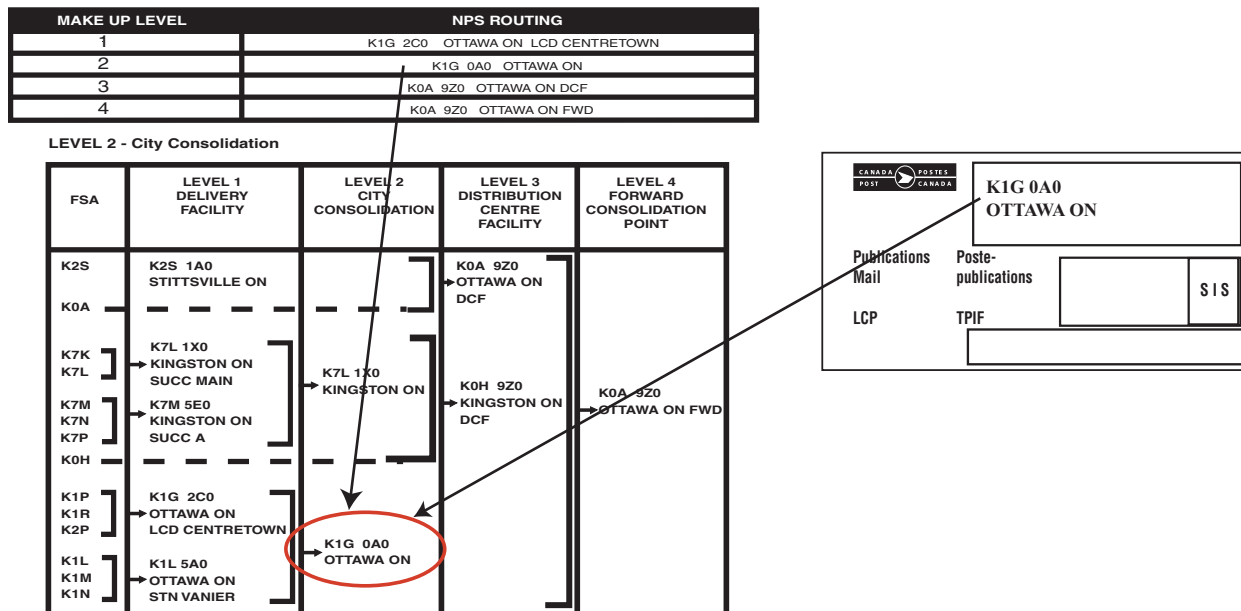

Figure 49:

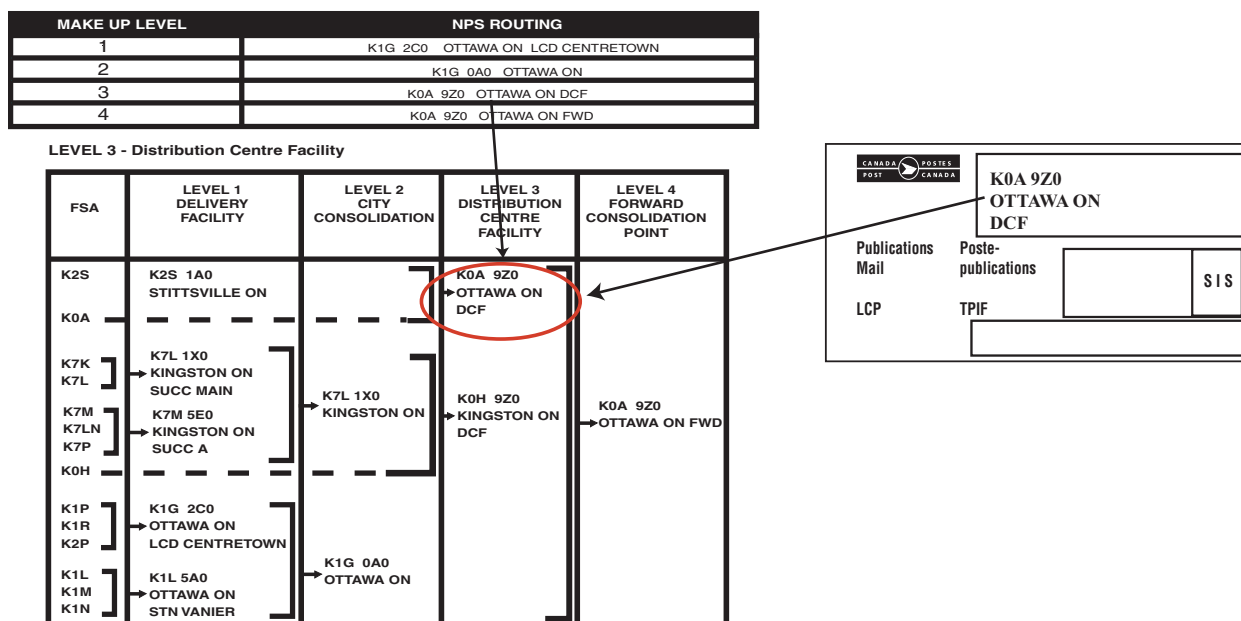
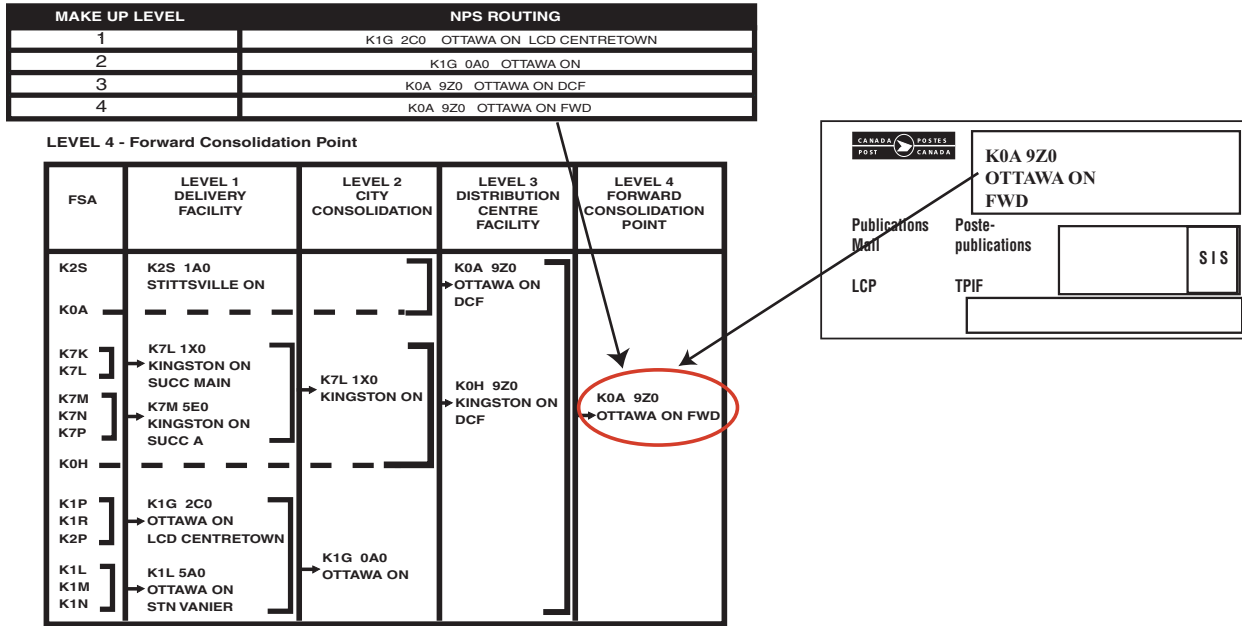

Figure 50:



6.1.2 LABELLING RESIDUE CONTAINERS

Labels for Residue containers and bags require the name of the Office of Deposit, as well as FWD and the word "Residue" (as shown in Figure 51). In certain areas, A Canada Post Representative may request that the Customer address the Residue containers/bags to the office responsible for processing the Residue mail instead of the Office of Deposit.

Figure 51:

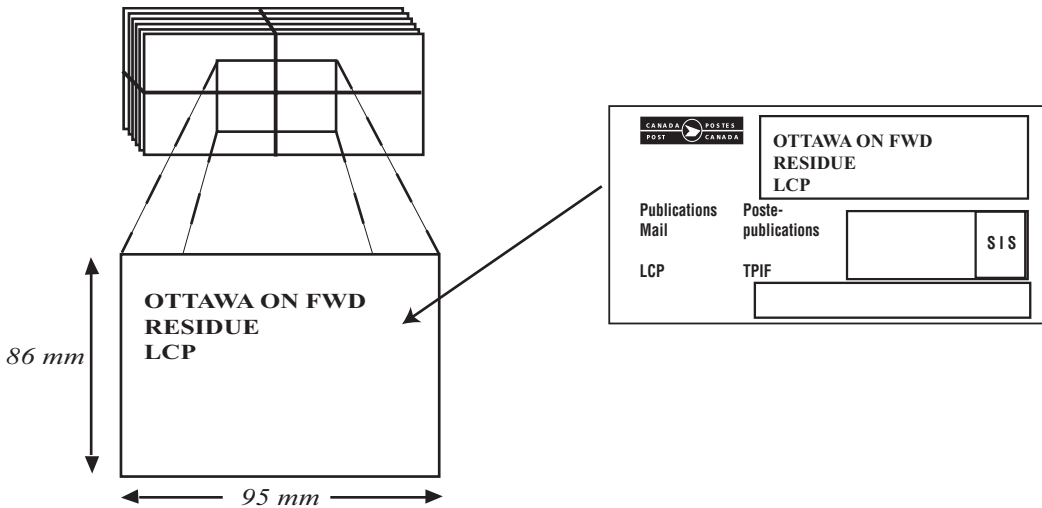

6.2 Labelling Hardsided Containers

Labels must be placed in the label holder on hardsided containers (as shown in Figure 52) before being deposited.

Figure 52:

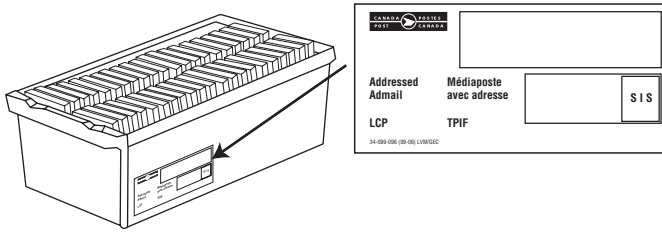

6.3 Labelling Bags

NOTE : The Customer cannot use bags for Dimensional Addressed Admail.

When the Customer deposits Canada Post mailbags, the Customer can label the mailbags with a vinyl label holder (which are used on their own, without keeper labels) or with tie-on tags and keeper labels. Attach all labels securely.

6.3.1 VINYL LABEL HOLDERS

The Customer may use a vinyl label holder (as shown in Figure 53) securely attached to the corner of the bag by a plastic cable tie or twine (as shown in Figure 54). If the Customer does, the Customer does not need to attach a tie-on tag or to produce a bag label (keeper tag). Customers need only insert a hardsided container label into the vinyl label holder.

Figure 53:



Figure 54:

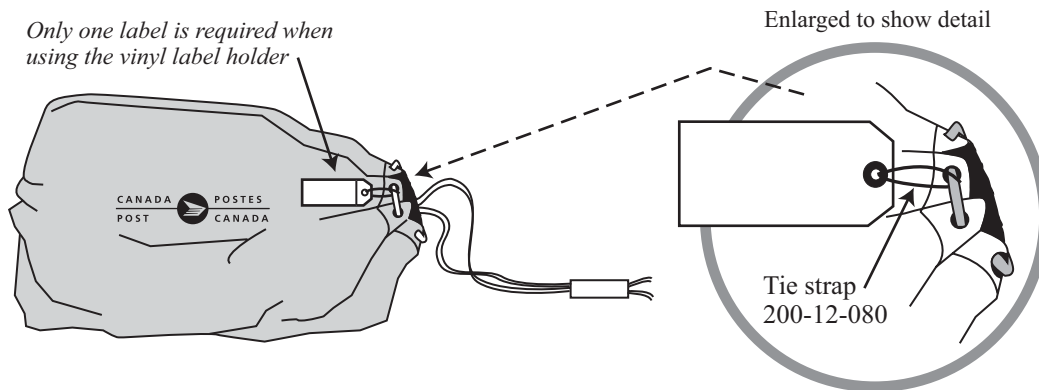

The Customer can order vinyl label holders (SO-54) and plastic tie straps (200-12-080) from the Canada Post Customer Relationship Network by calling 1-888-550-6333 or 1-800-260-7678.

6.3.2 TIE-ON TAGS AND BAG LABELS (KEEPER TAGS)

If the Customer does not use vinyl label holders, use tie-on tags on all mail bags fastening the tags securely by plastic cable ties or twine to the neck of the bag (as shown in Figure 55) before deposit.

Figure 55:

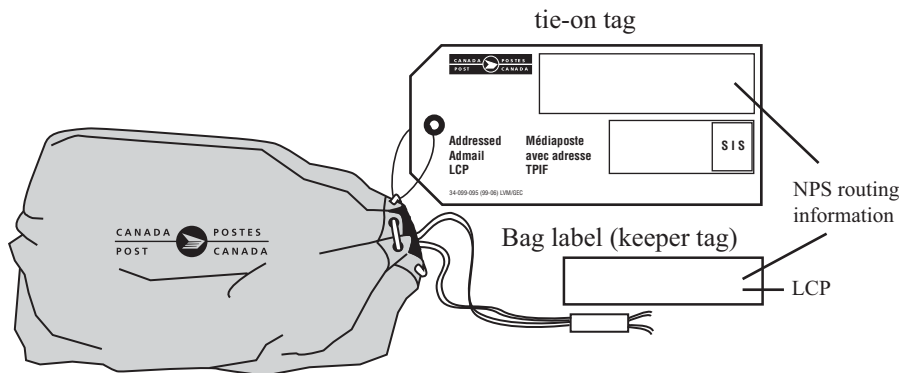

Bags with tie-on tags must also bear a bag label or keeper tag (as shown in Figure 56). Insert bag label in the label holder (as shown in Figure 55). Bag labels must contain the complete NPS Routing information for which the bundles are destined, and all the information must show after on the label which is then placed into the label holder.

Figure 56:

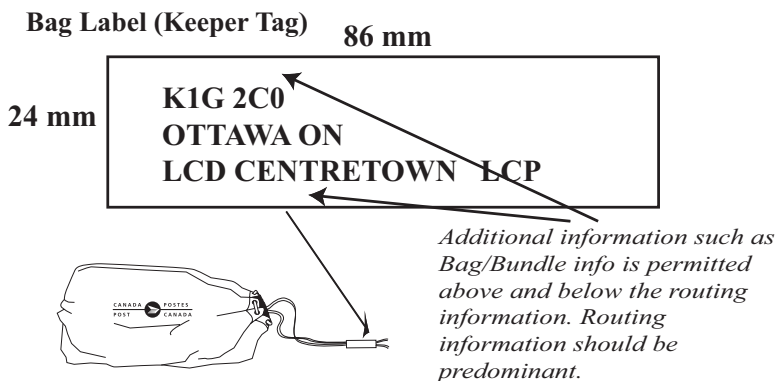

6.4 Producing Labels and Tie-on Tags

The Customer has three options for producing labels:

- ordering labels from Canada Post
- printing labels from Canada Post templates, or
- making custom labels using Canada Post specifications.

Customers can order labels, by contacting the Customer Relationship Network (1-888-550-6333 or 1-800-260-7678) and use the label form number to order labels. The label form numbers are listed in Table 14.

Table 14: Form Numbers for Labels and Tie-on Tags

TYPE OF MAIL	FORM NUMBER	ORDERING INFORMATION
Hardsided Container Labels		
Addressed Admail – Letter Carrier Presort (LCP)	34-099-096 (99-06) LVM/GEC (white stock with black ink)	Order from the Canada Post Customer Relationship Network 1-888-550-6333 1-800-260-7678
Dimensional Addressed Admail – LCP	34-099-119 (99-06) LVM/GEC (white stock with black ink)	
Publications Mail – LCP	34-099-088 (99-06) LVM/GEC (white stock with black ink)	
Publications Mail (Time-committed) – LCP	34-099-090 (99-06) LVM/GEC (white stock with terra cotta/PMS 470 ink; routing detail is printed in black)	
Tie-on Tags		
Addressed Admail – LCP	34-099-095 (99-06) LVM/GEC (white stock with black ink)	Order from the Canada Post Customer Relationship Network 1-888-550-6333 1-800-260-7678
Publications Mail – LCP	34-099-087 (99-06) LVM/GEC (white stock with black ink)	
Publications Mail (Time-committed) – LCP	34-099-582 (99-06) LVM/GEC (white stock with terra cotta/PMS 470 ink; routing detail is printed in black)	
Continuous Self-Adhesive Label*		
Dimensional Addressed Admail – LCP	34-099-120 (00-07) LVM/GEC (white stock with black ink)	Order from the Canada Post Customer Relationship Network 1-888-550-6333 1-800-260-7678

- * Continuous self-adhesive labels can be affixed only to Customer-supplied containers such as boxes or shrink-wrapped units, not to Canada Post equipment.

If the Customer is producing labels using Canada Post templates or producing their own labels, the site www.canadapost.ca/postalservices under Container Labels offers both camera-ready artwork for the templates and Canada Post specifications for producing custom labels.

NOTE : If the Customer is a large-volume mailer, the Customer may choose between producing labels individually or in continuous strips (1 up, 2 up, etc.) as best suited to the intended overprinting process.

6.4.1 SPECIAL INSTRUCTIONS FOR PRODUCING LABELS

- print one side only
- labels must fit into label holders and be easily extracted from the label holders
- labels must be in bilingual format
- use PMS 470 (Terra Cotta) colouring for time-committed Publications Mail.

7 MAKE UP MONOTAINERS AND PALLETS (STEP 5)

A monotainer (as shown in Figure 57) is a large, collapsible, steel-frame container provided by Canada Post. During peak periods, such as Christmas, the Customer may not always be able to obtain the number of monotainers needed.

A pallet (also referred to as a skid) is a platform used for the conveyance of hardsided containers or bags and/or Brick-piled mail items (visit www.canadapost.ca/mailpreparation under Brick-piling). Customers must provide their own pallets.

Figure 57:

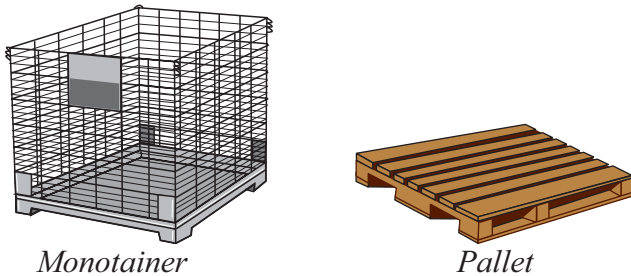

Monotainers and pallets keep together all mail intended for identical destination (e.g., all mail for Vancouver arrives on one pallet), which reduces the amount of handling and ensures a complete mailing arrives at its destination.

Use of monotainers or pallets is mandatory for Dimensional Addressed Admail. It is optional for Publications Mail and Addressed Admail but Canada Post encourages Customers to consolidate lettertainers and flats tubs by using monotainers or pallets and, if Customers have monotainers, to consolidate bags.

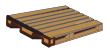
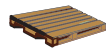
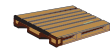
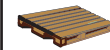



Table 15: Summary of Monotainer and Pallet Specifications

CATEGORY	PALLET	MONOTAINDER
Length	1.22 m	1.322 m
Width	1.02 m	1.067 m
Height	150 mm	1.115 m
Maximum weight (including mail and container)	900 kg	900 kg (monotainer is 97 kg)
Requirements	<ul style="list-style-type: none"> • minimum load: at least 18 lettertainers or 12 flats tubs • maximum load: 48 lettertainers or 32 flats tubs • minimum load height: 500 mm • maximum load height: 1.5 m (including height of the pallet) • stretch-wrapping required three times around the pallet as well as the pallet load • must allow four-way entry by a Canada Post forklift and two-way entry by a Canada Post pallet jack 	<ul style="list-style-type: none"> • holds 36 lettertainers or 24 flats tubs • contents may be piled up to 25 mm below the top of the monotainer
Fill requirements for mail destined for within province of deposit	No change in requirements by destination: <ul style="list-style-type: none"> • minimum load height 500 mm • maximum height (including pallet) 1.5 m 	<ul style="list-style-type: none"> • at least 18 lettertainers or 12 flats tubs • for presorted bags, at least 50 percent full by height (that is, not by weight)
Fill requirements for mail destined for outside province of deposit	No change in requirements by destination: <ul style="list-style-type: none"> • minimum load height 500 mm • maximum height (including pallet) 1.5 m 	<ul style="list-style-type: none"> • at least 27 lettertainers or 18 flats tubs • for presorted bags, at least 75 percent full by height

7.1 Using the NPS to Make up Monotainers and Pallets

The Customer may consolidate containers into monotainers or onto pallets for all four levels of the NPS, (as shown in Figure 58).

Figure 58:

NPS LEVELS			
LEVEL 1 URBAN DELIVERY FACILITY/ RURAL DELIVERY FACILITY	LEVEL 2 CITY	LEVEL 3 DCF	LEVEL 4 FCP
			
			

NOTE: Monotainer and pallet make-up is mandatory for Dimensional Addressed Admail and optional for Addressed Admail and Publications Mail.

If there are sufficient containers to fill a monotainer or pallet, make an Urban Delivery Facility or a Rural Delivery Facility (both Level 1) monotainer or pallet. Figure 59 shows the label the Customer would produce when there are enough containers to fill a monotainer or pallet for K1P, K1R and K2P. See section 7.2 “Labelling Monotainers and Pallets” on page 43 for more information about labelling.

Figure 59:

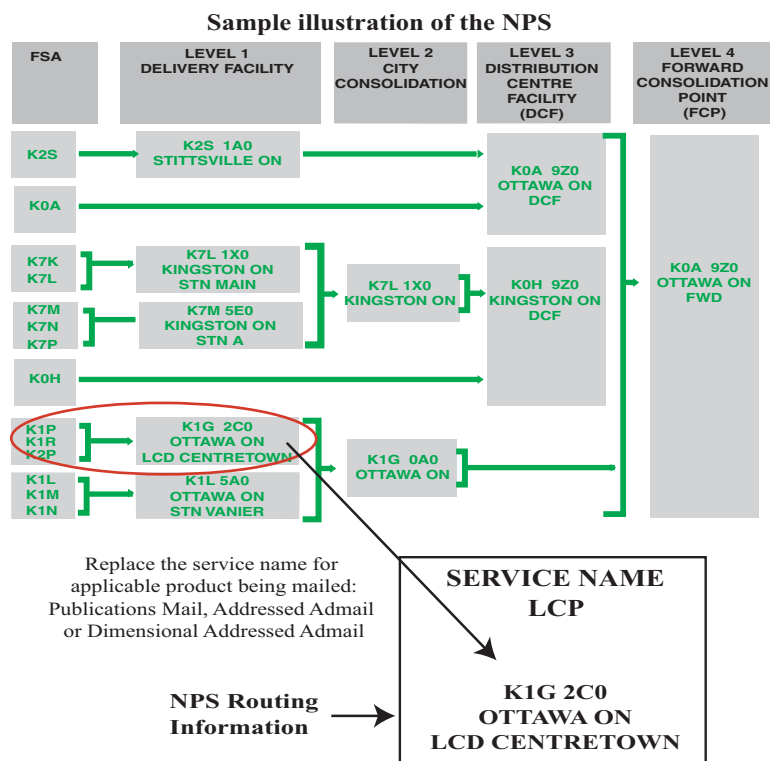

If not, the next option is to consolidate containers for more than one Urban Delivery Facility (as indicated by brackets of inclusion on the NPS) to make a City Consolidation (Level 2) monotainer or pallet. For example, consolidate containers for K1P, K1R and K2P with containers for K1L, K1M and K1N (as shown in Figure 60).

Figure 60:

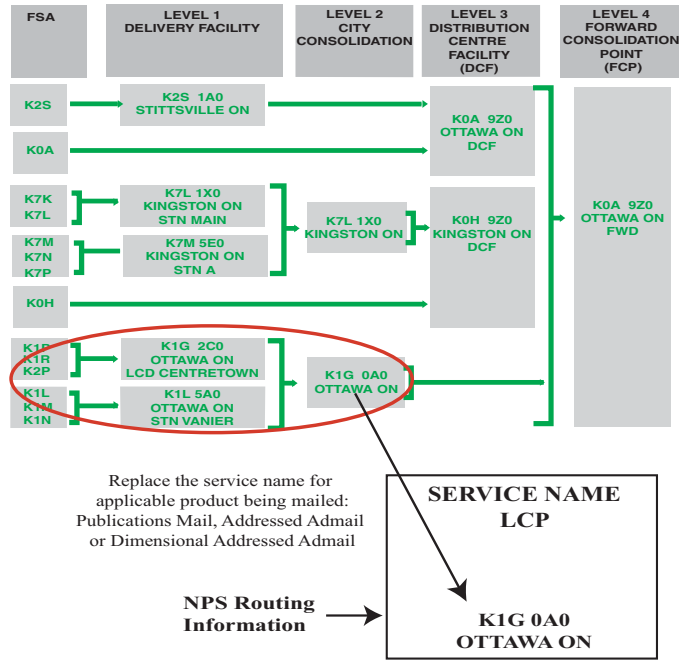

If the Customer does not have enough containers for City Consolidation, the Customer determines whether DCF Consolidation is permitted for the next level. If it is permitted, consolidate containers with other Urban and/or Rural Delivery Facilities (as indicated by brackets of inclusion on the NPS), to make a DCF (Level 3) monotainer or pallet. For example, consolidate containers for K7K and K7L above with those for K0H (as shown in Figure 61).

Figure 61:

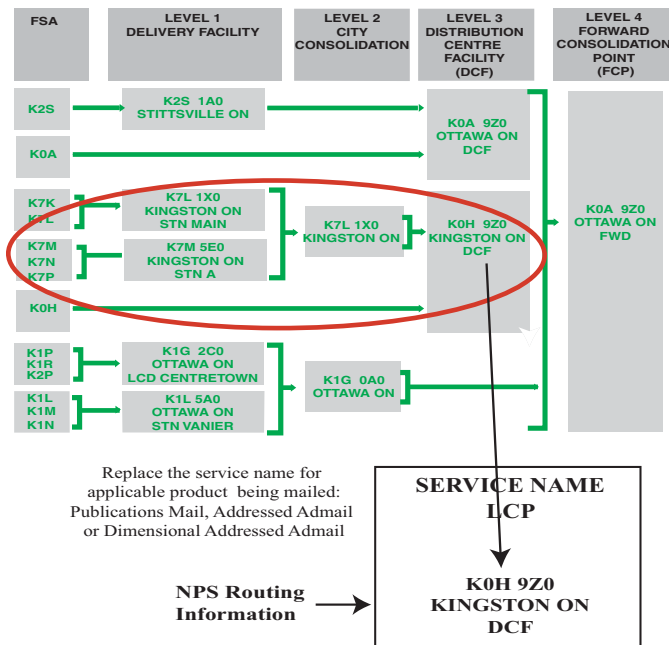

If DCF consolidation is not permitted or if there are not enough containers for DCF consolidation, consolidate containers with other Urban and/or Rural Delivery Facilities (as indicated by brackets of inclusion on the NPS), to make an FCP (Level 4) monotainer or pallet. For example, consolidate all of the above with containers for K2S and K0A (as shown in Figure 62).

Figure 62:

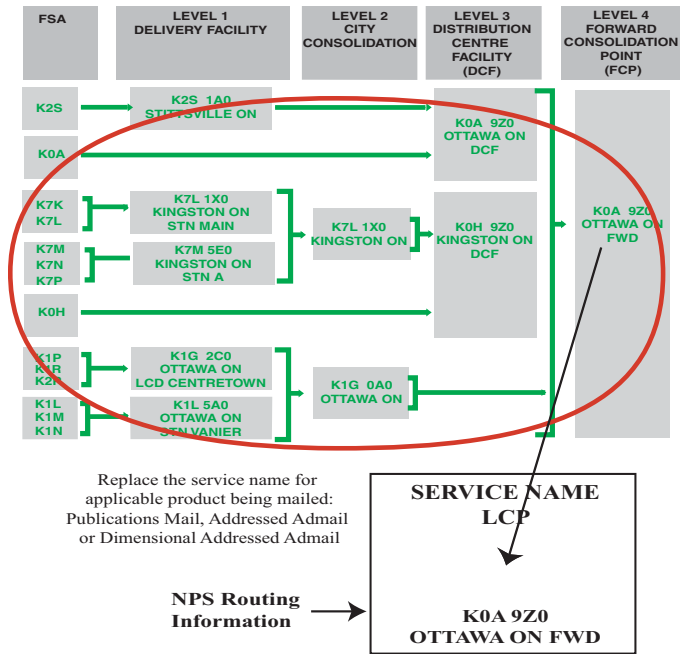

Remaining containers that cannot be consolidated to NPS Levels 1 to 4 can be placed in a Residue monotainer or pallet. Canada Post will accept mailings in which all mail has been consolidated into pallets or monotainers except the Residue containers.

7.2 Labelling Monotainers and Pallets

Labelling monotainers and pallets ensures that mail is directed to the appropriate work centre within a Canada Post facility.

Each label must be white with black lettering and must include the following information (as shown in Figure 63):

- Service name (Publications Mail, Addressed Admail or Dimensional Addressed Admail)
- Service option (e.g., LCP)
- National Presortation Schematic (NPS) routing information, if it is not a Residue container, as follows:
 - facility postal code (e.g., K0A 9Z0)
 - facility name (e.g., OTTAWA)
 - province abbreviation (e.g., ON, MB, SK), and
 - routing designation (e.g., DCF).

Figure 64 shows how what information should be on a Residue label for a monotainer or pallet.

Figure 63:

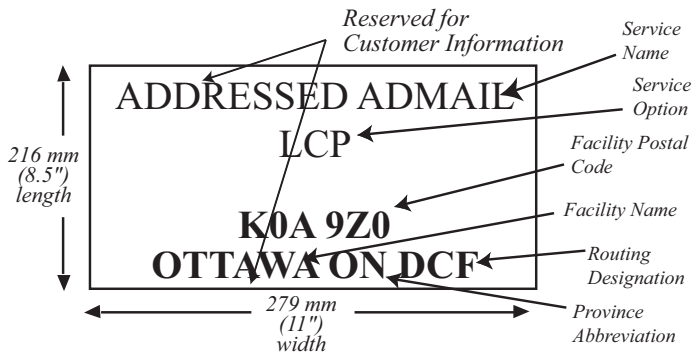
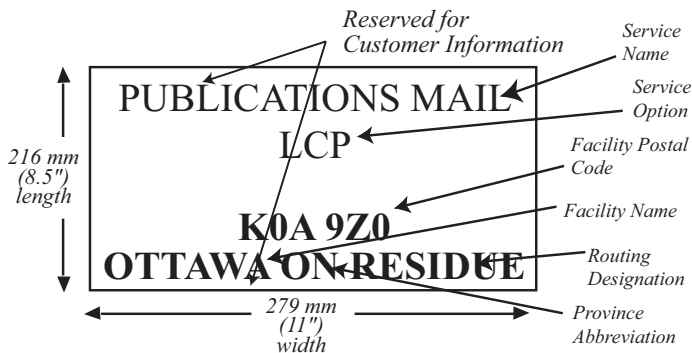

Figure 64:



Choose a font size large enough to use the entire label. The destination plant must be visibly larger than other information, including Customer information.

Each pallet or monotainer should have two labels on different sides (as shown in Figure 65).

Figure 65:

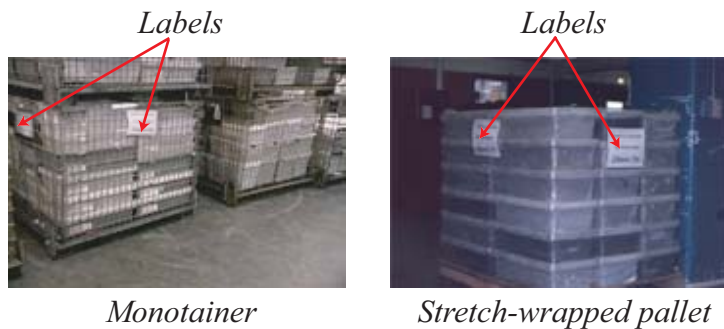

8 PREPARE THE MAILING SUMMARY (STEP 6)

8.1 What is a Mailing Summary?

The *Mailing Summary* is a software-generated report that captures the presortation details and parameters associated with the mailing. A Mailing Summary in hard-copy format is required for all LCP mailings, at the time and location of deposit. (An electronic version may be acceptable if prior approval from Canada Post obtained.)

The *Mailing Summary* must contain the following information, subject to approval by Canada Post.

8.1.1 GENERAL INFORMATION

- Customer name
- Customer address
- Customer telephone number
- Customer contract number
- Service name
- Service option
- Statement of Mailing #: (entered at a later date)
- Delivery Mode Data Product valid for mailing dates
- Delivery Mode Audit Code

8.1.2 SOFTWARE NAME AND VERSION

8.1.2.1 Software Parameters

- Lists all parameters and/or defaults used (i.e., piece weight, maximum container weight, Office of Deposit, etc.)
- # of Monotainers/Pallets
- # of Containers

Table 16: Volume Distribution

LEVELS OF CONSOLIDATION	RESTRUCTURED ITEMS	NON-RESTRUCTURED ITEMS	TOTAL ITEMS
Delivery Mode Direct			
Delivery Facility			
Distribution Centre Facility			
Forward Consolidation Point			
Residue			

8.2 Mailing Details

The Mailing Details are required only when requested by Canada Post. They must contain the following:

- monotainers and pallets (if applicable)
- within monotainers or pallets: containers
- within containers: groupings and bundles, and
- for groupings and bundles: Delivery Mode Details, type, size, and routing information (see section 6 “Label the Containers (Step 4)” on page 33 for more information).

Monotainer or pallet (if applicable) and container level, service option and routing information must also be indicated.

Table 17: Sample Layout for Monotainer/Pallet Summary

CONTAINER TYPE	NPS LEVEL OF ACCESS	ROUTING INFORMATION
Monotainer #1	FCP	VOE 9Z0 KAMLOOPS BC FWD
Lettertainer #1	CITY	V2C 5P0 KAMLOOPS BC

Table 18: This is a part of the software breakdown by Presort

GROUPING	TYPE	VOLUME	DMC	ROUTING INFORMATION
1	DMD	15	3	V2B 3H0 KAMLOOPS BC STN NORTH DEL CTR
2	DMD	12	8	V2B 3H0 KAMLOOPS BC STN NORTH DEL CTR
3	DMD	20	12	V2C 5P0 KAMLOOPS BC STN SOUTH DEL CTR
4	DF	20		V2C 5P0 KAMLOOPS BC STN SOUTH DEL CTR
5	DF	8		V2C 5P0 KAMLOOPS BC STN SOUTH DEL CTR
6	DF	50		V2C 5P0 KAMLOOPS BC STN SOUTH DEL CTR
		Total		
		125		

Table 19: Delivery Office Volume Summary

TYPE OF CONTAINER AND COUNT	ITEM COUNT	DELIVERY INSTALLATION POSTAL CODE	ROUTING INFORMATION
1 Lettertainer	51	JOB 9Z0	SHERBROOKE QC DCF
3 Flat Tubs	44	JOE 9Z0	GRANBY QC DCF
Total			
4	95		

8.3 Letter Carrier Volume Summary (Dimensional Addressed Admail only)

An electronic version of the Letter Carrier Presort Volume Summary is required by Canada Post 10 business days before a deposit of Dimensional Addressed Admail. The 10-day advance notice allows Canada Post to hire additional resources/equipment/transportation to accommodate the Dimensional Admail if necessary.

Table 20:

DMD	ITEM COUNT	DELIVERY INSTALLATION POSTAL CODE	ROUTING INFORMATION
1	51	V8C 1T0	KITIMAT BC STN MAIN
3	44	K9V 3B0	LINDSAY ON STN MAIN