

**ALBERTA
SENIORS
ANNUAL
REPORT**

2002-2003



PREFACE

The Public Accounts of Alberta are prepared in accordance with the *Financial Administration Act* and the *Government Accountability Act*. The Public Accounts consist of the annual reports of each of the 24 ministries.

The annual report of the Government of Alberta released June 24, 2003 contains the Minister of Finance's accountability statement, the consolidated financial statements of the Province and a comparison of the actual performance results to desired results set out in the government's business plan, including the *Measuring Up* report.

This annual report of the Ministry of Seniors contains the Minister's accountability statement, the audited consolidated financial statements of the ministry and a comparison of actual performance results to desired results set out in the ministry business plan. This ministry annual report also includes:

- the financial statements of entities making up the ministry including the Department of Seniors and the Alberta Social Housing Corporation for which the Minister is responsible,
- other financial information as required by the *Financial Administration Act* and *Government Accountability Act*, either as separate reports or as a part of the financial statements, to the extent that the ministry has anything to report.

MINISTER'S ACCOUNTABILITY STATEMENT

The Ministry's Annual Report for the year ended March 31, 2003, was prepared under my direction in accordance with the *Government Accountability Act* and the government's accounting policies. All the government's policy decisions as at September 8, 2003 with material economic or fiscal implications of which I am aware have been considered in the preparation of this report.

Original signed by
Stan Woloshyn
Minister of Seniors

TABLE OF CONTENTS

Message from the Minister	5
Management’s Responsibility for Reporting.....	7
Overview	
Ministry Entities	9
Operational Overview	10
Summary of Key Activities	15
Results Analysis	
Auditor General’s Report	22
Ministry Expense by Core Business	23
Results by Core Business	23
Corporate Strategies	43
Looking Forward	45
Financial Performance Highlights	48
Financial Information	
Financial Statements	53
Alphabetical List of Government Entities’ Financial Statements	122

MESSAGE FROM MINISTER

It is my privilege to present the Alberta Seniors annual report for the fiscal year ended March 31, 2003.

My ministry's vision for Alberta is a vibrant province where seniors and other Albertans live with dignity and experience the best possible well being and independence. This annual report documents the many accomplishments of my ministry in 2002-03 towards fulfilling that vision.

The 2002-03 fiscal year was a very successful one for the ministry. We operated within our approved budget and our clients and stakeholders expressed a high level of satisfaction with our services, as is documented in our performance measures. These results speak to the dedication of my ministry staff in providing exemplary service to both seniors and lower-income Albertans in need of housing.

We were quick to respond when rising utility costs resulted in financial hardships for many low-income seniors. The flexibility of the Special Needs Assistance for Seniors program enabled my ministry to temporarily change the program to include rising utility costs as an allowable expense. This provided low-income seniors most in need with financial assistance with the increase in their utility costs.

Another initiative undertaken by the ministry was to enhance access to information on seniors' programs and services. Following transfer of Seniors Services Offices to Alberta Seniors in April 2002, the ministry developed partnerships with seniors' organizations in Lethbridge, Calgary and Red Deer, to facilitate more direct services to seniors. This new model of service focused on working more closely with seniors' organizations and taking services directly to seniors.

In 2002-03, we continued to support the provision of basic housing and shelter for low-income seniors, families, individuals and persons with special needs. We contributed funding towards the development of 420 much needed affordable housing units for lower-income Albertans through the Canada-Alberta Affordable Housing Program Agreement

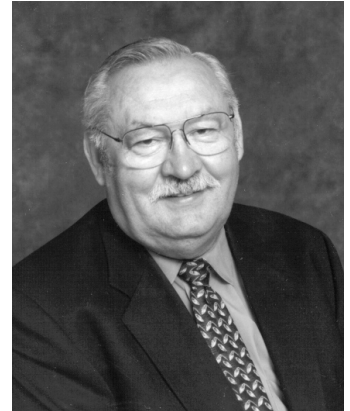

that was signed in June 2002. This agreement provides \$67.12 million in federal funds over five years, to be matched by an equal contribution from the province, and used for increasing the supply of affordable housing in high-need areas of the province.

In addition to affordable housing, 321 supportive housing units for lower-income seniors were completed under the Healthy Aging Partnership Initiative and the Seniors Supportive Housing Incentive Program. Through the Provincial Homelessness Initiative, the ministry continued to work in partnership with the federal/municipal governments and community organizations to develop shelter units for homeless Albertans. Alberta Seniors' annual investment of \$3 million has, over the last three years, generated approximately \$81.6 million in additional contributions from municipalities and community organizations, in addition to \$50 million provided in federal funds. I am proud to report that the ministry was awarded a Silver Premier's Award of Excellence in recognition of the department's achievements in addressing housing for homeless people in Alberta through the Provincial Homelessness Initiative.

As we continue to work towards our vision, we do so in a fiscally responsible manner thus ensuring that our programs and services remain viable and meaningful into the future. To foster sustainability over the long term, my ministry will continue to analyze social and economic trends to help set a future direction for policy and planning initiatives.

I commend my ministry staff, stakeholder groups and our many partners for the excellent progress we have made in making Alberta a better place to live for seniors and lower-income Albertans in need of housing.

Original signed by
Stan Woloshyn
Minister, Alberta Seniors

MANAGEMENT'S RESPONSIBILITY FOR REPORTING

The Ministry of Seniors includes the Department of Seniors, and the agency and corporation listed on the ministry entities chart on page nine.

The executives of the individual entities within the ministry have the primary responsibility and accountability for the respective entities. Collectively, the executives ensure the ministry complies with all relevant legislation, regulations and policies.

Ministry business plans, annual reports, performance results and the supporting management information are integral to the government's fiscal and business plans, annual report, quarterly reports and other financial and performance reporting.

Responsibility for the integrity and objectivity of the consolidated financial statements and performance results for the ministry rests with the Minister of Seniors. Under the direction of the Minister, I oversee the preparation of the ministry's annual report, including consolidated financial statements and performance results. The consolidated financial statements and the performance results, of necessity, include amounts that are based on estimates and judgments. The consolidated financial statements are prepared in accordance with the government's stated accounting policies.

As Deputy Minister, in addition to program responsibilities, I establish and maintain the ministry's financial administration and reporting functions. The ministry maintains systems of financial management and internal control which give consideration to costs, benefits, and risks that are designed to:

- provide reasonable assurance that transactions are properly authorized, executed in accordance with prescribed legislation and regulations, and properly recorded so as to maintain accountability of public money,

-
- provide information to manage and report on performance,
 - safeguard the assets and properties of the province under ministry administration,
 - provide Executive Council, Treasury Board, the Minister of Finance and the Minister of Seniors any information needed to fulfill their responsibilities, and
 - facilitate preparation of ministry business plans and annual reports required under the *Government Accountability Act*.

In fulfilling my responsibilities for the ministry, I have relied, as necessary, on the executive of the individual entities within the ministry.

Original signed by
Ken J. Wilson
Deputy Minister
August 26, 2003

OVERVIEW

MINISTRY ENTITIES

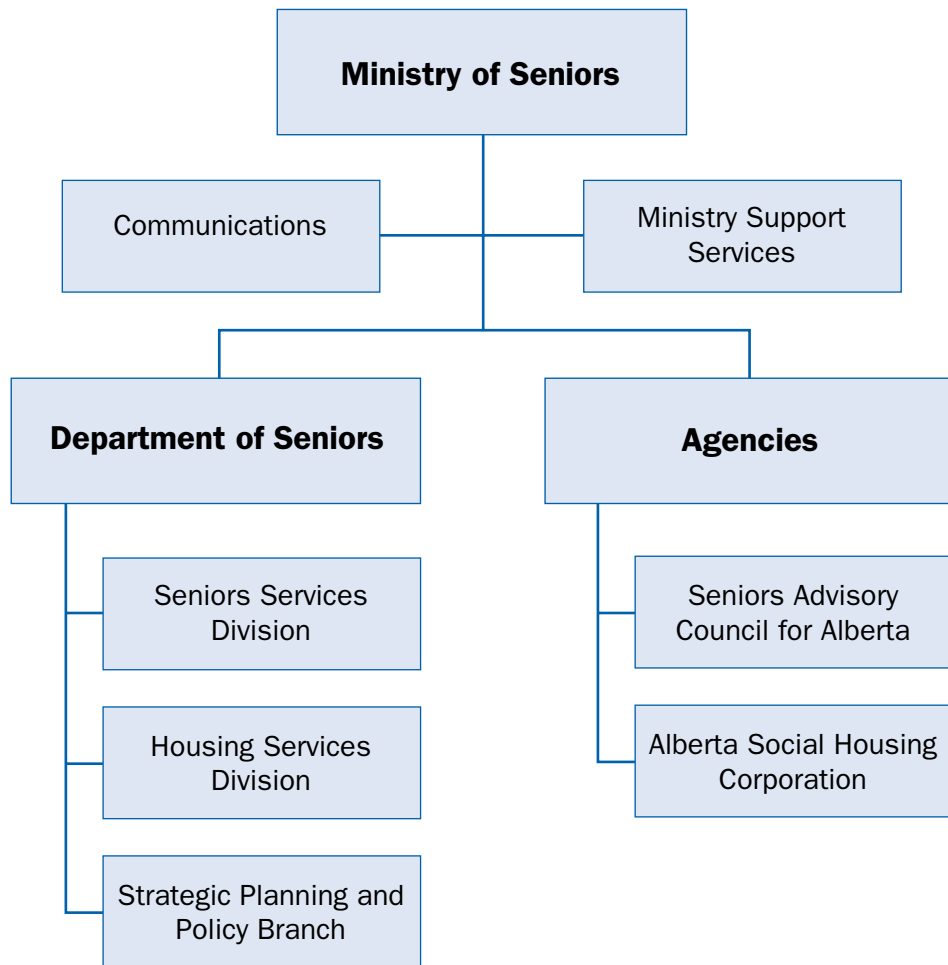

OPERATIONAL OVERVIEW

Alberta Seniors' mission for 2002-03 was: *To provide services, programs and information to seniors, and to Albertans in need of housing.*

In 2002-03, the ministry had three core businesses, as follows:

1. Provide financial support and information services to seniors;
2. Support provision and management of seniors, family and special purpose housing; and,
3. Provide planning and policy development for seniors and housing.

The Department

In 2002-03, Alberta Seniors was composed of Seniors Services Division, Housing Services Division, and Strategic Planning and Policy Branch, with support provided by Ministry Support Services (Corporate Services) and Communications.

Seniors Services Division

The Seniors Services Division is responsible for delivering the ministry's financial support programs to low-income seniors and providing information to the public on seniors' programs and services. It is comprised of three branches and also has administrative responsibility for the Seniors Advisory Council for Alberta.

The Seniors Financial Assistance Branch administers the Alberta Seniors Benefit program under the *Seniors Benefit Act*. Through this program, the branch delivers income-based, monthly cash benefits to eligible seniors and determines the level of exemption from Alberta Health Care Insurance Plan premiums for low-income seniors. To ensure that supports continue to be targeted to seniors most in need of assistance, the branch monitors issues relating to seniors' financial situations, and supports research activities on seniors' incomes.

The Special Needs Assistance for Seniors Branch administers the Special Needs Assistance for Seniors program. This is an income-based program that provides a lump-sum cash payment to eligible low-income seniors who demonstrate that they are experiencing financial difficulties or unexpected expenses above their basic living requirements. The amount received is based on income and the amount of an applicant's allowable extraordinary expenses. The maximum payment in any one year is \$5,000.

The Client and Information Services Branch provides information, focusing on the Alberta Seniors Benefit and Special Needs Assistance for Seniors programs, through telephone access, letters, the Alberta Seniors website, and by coordinating services provided by regional Seniors Information Services Offices. It provides additional information to seniors and service providers by producing publications such as the annual *Programs and Services for Seniors* booklet, and promotes knowledge and understanding of seniors and their contributions. The branch also provides administrative support to the Seniors Advisory Council for Alberta.

Strategic Planning and Policy Branch

The Strategic Planning and Policy Branch works with other government departments and stakeholders to ensure that seniors' issues are considered in government and non-government initiatives. The branch monitors demographic, economic and social trends, undertakes policy research, and provides information to assist the ministry in developing responses to issues affecting seniors, seniors' housing, and planning for Alberta's aging population. The branch coordinates federal/provincial/territorial activities relating to seniors and seniors' housing. As well, the branch coordinates the development of the ministry three-year business plan and the annual report, and coordinates ministry-wide initiatives, such as legislative and regulatory reviews, and in 2002-03 was responsible for strategic human resources planning.

Housing Services Division

The Housing Services Division ensures that provincially-owned and/or -supported housing is effectively managed by local housing providers, non-profit organizations, and municipalities, and provides housing for lower-income families, individuals with special needs, and seniors. It also manages the assets of the Alberta Social Housing Corporation. These services are delivered through three branches.

The Housing Innovation and Policy Branch provides strategic research, analysis, planning, and support on a broad range of family and special purpose housing issues for the Minister, Deputy Minister and the division. It also plays a leadership role in coordinating the division's legislation development, business planning and reporting requirements for all housing programs.

The Major Housing Initiatives and Program Delivery Branch assists local governments, not-for-profit and private sector organizations in providing affordable and appropriate housing options for low-income earners, persons with special needs, and homeless persons. The branch achieves this through administering operating and capital funding; administering ministry-owned properties for the provision of emergency, transitional, and other forms of low-income housing accommodation; and delivering information, advice and referral services on tenancy, maintenance and security for residents in lower-income housing.

The Division Support Branch administers homeless shelter contracts, housing grant programs and the mortgages and loan guarantees of the Alberta Social Housing Corporation, and provides central support services to the Assistant Deputy Minister of the Housing Services Division.

Ministry Support Services

Corporate Services

Corporate Services within the ministry include strategic services in the areas of financial planning and reporting, information technology (which Alberta Seniors also provided to the Ministry of Community Development), and administration of the *Freedom of Information and Protection of Privacy Act*. During 2002-03, the ministry also received some strategic financial and administrative services through a contract with Community Development's Strategic Corporate Services Division. Alberta Corporate Services Centre is contracted to provide transactional services in finance, human resources, administration and information technology.

Communications

Communications assists the ministry in communicating initiatives identified in the ministry's business plan to target audiences.

Communications was very active in communicating a number of issues that arose during 2002-03. In addition, Communications provides consulting services in the areas of issues management, media relations—including acting as ministry spokesperson—strategic writing, and technical support and expertise.

Agencies

Seniors Advisory Council for Alberta

The Seniors Advisory Council for Alberta brings the views of seniors to the attention of government. The council makes recommendations to the government on the coordination of policies and programs relating to seniors, and responds to government reports and specific requests for advice. It is also responsible for coordinating the annual Seniors' Week celebrations.

Alberta Social Housing Corporation

The Alberta Social Housing Corporation is an agent of the Crown operating under the authority of the *Alberta Housing Act*. The corporation is the owner of a substantial portfolio of housing and land assets, and facilitates the provision of social housing to low-income families and individuals, and those with special needs. The officers of the corporation are all employees of the Alberta government and are primarily the senior management of Alberta Seniors.

SUMMARY OF KEY ACTIVITIES

The following provides a summary of some of the business plan activities that the ministry engaged in during 2002-03. Key program initiatives, improvements in efficiency, consultations with stakeholders, and outsourcing initiatives are noted within this summary.

CORE BUSINESS 1:

Provide financial support and information services to seniors

Goal 1.1: Seniors in need have access to financial supports that enable them to live in a secure and dignified way.

- A preliminary model for forecasting seniors' income needs was developed and used to generate cost projections for the adjustment to the Alberta Seniors Benefit program income thresholds implemented in July 2002, and for the 2003-04 budget planning process. Forecasting the income needs of future seniors is an important part of the ministry's planning process for providing a level of support to both current and soon-to-be seniors.
- The ministry began participating in a new Canada Customs and Revenue Agency initiative that will provide quicker and more efficient access to information needed for annual adjustments to seniors' benefits to reflect their changes in income. The ministry obtains permission from seniors to use income information collected by Canada Customs and Revenue Agency.
- A successful campaign was conducted to encourage seniors to opt for direct deposit of their Alberta Seniors Benefit payments, as a more secure and convenient way to receive their benefits.
- The ministry revised the Special Needs Assistance for Seniors program application form to make it simpler and easier to complete.

Goal 1.2: Seniors and their families have access to information and educational material about programs, services, and initiatives that are designed to enhance their well being.

- Following the transfer of Seniors Services Offices from Alberta Community Development to Alberta Seniors on April 1, 2002, the ministry developed partnerships with seniors' organizations in Lethbridge, Calgary and Red Deer to deliver seniors information services in these cities and surrounding regions. These partnership agreements were part of a new model of working more closely with seniors' organizations and taking services directly to seniors.
- The ministry supported *Service Alberta*, a one-stop source of Government of Alberta information and services for citizens, in developing specific information for Albertans retiring or turning age 65. The information was placed on the *Service Alberta* website with a link on the Alberta Seniors website.
- Alberta Seniors continued to coordinate Alberta's contribution to the national *Seniors Policies and Programs Database*, <http://www.sppd.gc.ca/>. Launched in 2000 by the federal, provincial and territorial Ministers responsible for Seniors, the database is an Internet-based source of information on more than 400 federal, provincial and territorial government programs and policies relating to seniors.
- The ministry continued to chair the Seniors Fraud Awareness Committee, which took a lead role in the development of the seniors fraud awareness campaign, *If in Doubt, Check it Out*. Partners in this project include Alberta Children's Services, Alberta Government Services, Alberta Solicitor General, the Calgary and Edmonton Police Services, the RCMP, the Better Business Bureau, the Calgary Seniors Resource Society, the Edmonton Elder Abuse Intervention Team, and the Kerby Centre for Seniors.

- Through 2002-03, the ministry continued to advise communities on potential sources of grants in support of seniors' activities, and continued to raise issues of importance to seniors in discussions with provincial, federal and municipal departments responsible for resource allocation.
- The members of the Seniors Advisory Council for Alberta consulted with seniors and service providers at more than 100 meetings and events across the province to identify issues of which government should be aware. The council conducted tours of seniors' centres and housing facilities in Barrhead and the surrounding area, and published a report on its findings. The council also responded to government reports and specific requests for advice, and coordinated the annual Seniors' Week celebrations.

CORE BUSINESS 2:

Support provision and management of seniors, family and special purpose housing

Goal 2.1: Provincially-owned and -supported housing to meet the basic needs of low-income families and individuals, seniors, and persons with special needs is effectively managed and coordinated.

- The ministry examined a range of funding models, and consulted with the Alberta Senior Citizens' Housing Association, to develop a new funding formula for the Seniors Lodge Assistance Program. The formula will target assistance to low- and moderate- income seniors, and recognize the higher costs of small facilities.
- The ministry conducted bi-annual housing vacancy surveys of subsidized housing. These surveys establish the numbers and types of housing available to ensure that provincially-owned and -supported family and special purpose housing is targeted to those most in need.
- The ministry continued to pursue its policy of divesting those parts of its housing portfolio that are more appropriately owned and managed by municipalities and community housing operators.
- The rent supplement program continued to assist low-income families and individuals by reducing the cost of rents in the private housing rental market, which have risen across Alberta in the last few years. In the absence of increases to the program's budget, it was necessary to limit reassignments of rent supplements as units became vacant.

Goal 2.2: Seniors, low-income families and individuals, and persons with special needs have access to a range of housing appropriate to their needs at reasonable cost.

- Key strategies for facilitating accessibility and availability of low-cost and affordable housing included the completion of projects under the Seniors Supportive Housing Incentive Program/Healthy Aging Partnership Initiative and the signing and initiation of the Canada-Alberta Affordable Housing Program Agreement. The ministry continued its support of housing developments designed to ease the shortage of affordable housing in Fort McMurray.
- The ministry also developed a sustainable remote housing initiative to address the urgent need by many northern and remote communities for subsidized housing.
- Through the Provincial Homelessness Initiative, the ministry committed \$3 million annually over a three-year period to address housing for homeless people in Alberta's major urban centres. This commitment generated investment partnerships with municipalities, private and non-profit sectors, and community organizations totaling \$81.6 million. In addition, \$50 million in federal funds have been contributed by the National Homelessness Initiative over a period of three years.
- During 2002-03, preparations began for the consolidation of responsibility for supporting government homeless shelter-related activities within the Ministry of Seniors, effective April 1, 2003. This involved transferring responsibility for 16 emergency shelters and three support programs, as well as Gunn Centre, from Alberta Human Resources and Employment to Alberta Seniors. It is expected that this transfer will help to integrate shelters with other forms of housing so that Albertans in need of shelter will be able to move into longer-term affordable housing.

CORE BUSINESS 3:

Provide planning and policy development for seniors and housing

Goal 3.1: Government policies and plans effectively anticipate and address the needs of seniors and Albertans in need of housing supports.

- Alberta Seniors co-championed the cross ministry Health Sustainability Initiative with Alberta Health and Wellness and Alberta Finance. The ministry worked closely with Alberta Health and Wellness on several of the initiative's first-year targets.
- Assistance with the increase in utility costs was provided through the Special Needs Assistance for Seniors program to low-income seniors who were experiencing financial difficulties because of high utility costs during the winter of 2002-03.
- Alberta Seniors worked with the University of Alberta Department of Dentistry and Dental Hygiene to develop an agreement for funding the university department for the provision of dental services to low-income seniors.
- Alberta Seniors worked with other ministries to monitor and analyze key issues such as health reform and long-term care. Through its membership on interdepartmental and cross ministry committees and working groups, the ministry continued to contribute key information to initiatives and activities related to family violence, transportation, homelessness, and disabled parking. The ministry brought the perspectives of an aging population to the Labour Force Planning Committee of the cross ministry Economic Development Strategy, and the perspectives of housing to the cross ministry Aboriginal Policy Initiative.

- To ensure that the ministry was kept informed of community issues relating to seniors and housing, ministry officials met regularly with stakeholders, including the Policy Advisory Network of the Alberta Council on Aging and the Alberta Senior Citizens' Housing Association.
- The Minister of Seniors continued to represent Alberta Seniors on the federal/provincial/territorial forum of Ministers responsible for Seniors, and the forum of Housing Ministers, both of which meet on a periodic basis. In 2002, the Ministers responsible for Seniors held their meeting in Toronto. Following direction from the ministers, Alberta Seniors, as chair of the federal/provincial/territorial working group for the National Framework on Aging, began preparations for a new promotion of the Seniors Policies and Programs Database.



Report of the Auditor General on the Results of Applying Specified Auditing
Procedures to Performance Measures

To the Members of the Legislative Assembly

In connection with the Ministry of Seniors' performance measures included in the
2002-2003 Annual Report of the Ministry of Seniors I have:

1. Agreed information from reports that originated from organizations included in the consolidated financial statements of the Ministry to source reports. In addition, I tested the procedures used to compile the underlying data into the source reports.
2. Checked that the presentation of results is consistent with the stated methodology.
3. Checked that the results presented are comparable to stated targets, and information presented in prior years.
4. Checked that the performance measures, as well as targets, agree to and include results for all of the measures presented in Budget 2002.

As a result of applying the above procedures, I found no exceptions. These procedures, however, do not constitute an audit and therefore I express no opinion on the performance measures included in the *2002-2003 Annual Report of the Ministry of Seniors*.

Original signed by
Fred J. Dunn
FCA
Auditor General

Edmonton, Alberta
August 1, 2003

RESULTS ANALYSIS

MINISTRY EXPENSE BY CORE BUSINESS

CORE BUSINESS	in millions		
	2003		2002
	Authorized Budget	Actual	Actual
1. Provide financial support and information services to seniors	\$ 191.8	\$ 189.5	\$ 175.8
2. Support provision and management of seniors, family and special purpose housing	173.9	175.6	178.3
3. Provide planning and policy development for seniors and housing	0.9	0.8	0.8
	<u>\$ 366.6</u>	<u>\$ 365.9</u>	<u>\$ 354.9</u>

CORE BUSINESS 1: PROVIDE FINANCIAL SUPPORT AND INFORMATION SERVICES TO SENIORS

Goal 1.1:
Seniors in need have access to financial supports that enable them to live in a secure and dignified way.

The ministry offers two programs to assist low-income seniors to meet their basic needs and live in a secure and dignified way. Alberta Seniors Benefit is an income-based program designed to assist eligible seniors by providing monthly cash benefits and calculating their Alberta Health Care Insurance Plan premium exemptions. Special Needs Assistance for Seniors program is an income-based program that provides lump-sum payments to assist seniors who find themselves experiencing financial difficulties or unexpected expenses.

Supports Government of Alberta Goals 4 and 5:

Goal 4: Albertans will be independent

Goal 5: Albertans unable to provide for their basic needs will receive help

Providing financial assistance to low-income seniors

As of March 2003, there were 183,965 seniors receiving benefits from the Alberta Seniors Benefit program, an increase of 2,891 from 2001-02. This total represented about 57 per cent of Alberta seniors. Of these, 124,697 received a monthly cash benefit, averaging approximately \$122 per household (consisting of one or two seniors). These seniors also received full exemption from their health insurance premiums. The remaining 59,268 beneficiaries received full or partial exemption from their Alberta Health Care Insurance Plan premiums

The graph below presents data derived from a total of 323,376 seniors recorded in the Alberta Seniors Benefit database.

Percentage of seniors receiving Alberta Seniors Benefit (as of March 2003)

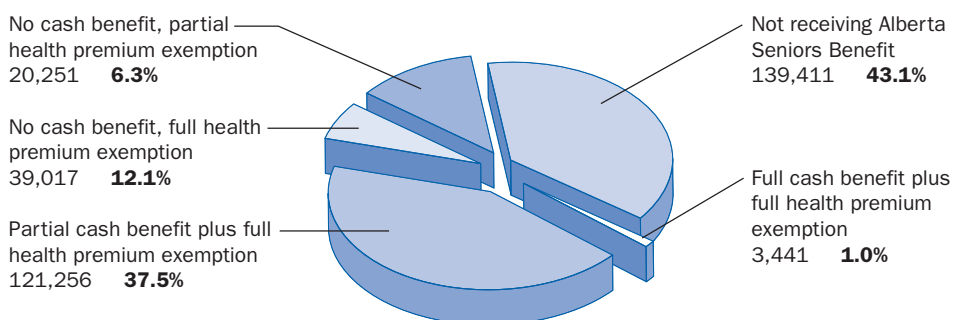

Source: Alberta Seniors Benefit database

The Special Needs Assistance for Seniors program experienced a 106 per cent increase in applications compared with the 2001- 02 fiscal year. The increase was partly due to improved publicity, the increased assistance for seniors' dental and optical expenses following the elimination of the Extended Health Benefits program and assistance with increased utility costs. The Special Needs Assistance for Seniors program provided lump sum payments to approximately 17,000 seniors for extraordinary or emergency expenses of between \$50 and \$5,000. Total expenditure in this program was \$23.7 million.

Providing flexible programs that recognize seniors' changing needs

Income benefits need to reflect not only the pressures of rising costs on seniors with fixed incomes, but also the fact that many seniors, as they age, need additional supports. In July 2002, income thresholds for the Alberta Seniors Benefit program cash benefit were increased to \$18,745 (up from \$18,440) for single seniors and \$28,530 (up from \$27,925) for couples.

Making it easier for seniors to get the benefits for which they are eligible

Following a campaign to promote direct deposit of Alberta Seniors Benefit program payments, more than 13,000 program recipients switched to direct deposit to receive their benefits. This was in addition to 58,000 already using this option. Providing Alberta Seniors Benefit payments through direct deposit at a senior's bank rather than by mail is a more secure, convenient and faster way for seniors to receive their benefits.

In response to concerns raised by seniors, the ministry revised the Special Needs Assistance for Seniors program application form. The new form is simpler and easier to complete, and contributed to a faster turnaround time for the assessment of applications, despite a significant increase in volume. The average application assessment time in 2002-03 was 12 days.

PERFORMANCE MEASURE

Measure: Percentage of eligible seniors receiving Alberta Seniors Benefit¹

A major endeavour of the ministry in 2002-03 was ensuring that all eligible seniors were given the opportunity to apply for Alberta Seniors Benefit. As the program helps low-income seniors maintain their independence and live in a secure and dignified way, it is important that seniors receive the benefits for which they are eligible.

Since the Alberta Seniors Benefit program is a voluntary program, this measure is designed to determine the extent to which seniors have had the opportunity to apply for benefits. If it can be demonstrated that seniors have been made aware of the program, have received an application package, and have been able to complete and return the application, this will indicate that the ministry has been successful in communicating the program.

Development of this measure is now complete, and data collection and analysis began in April 2003. Initial results are expected to be available for the 2003-04 annual report.²

¹ This measure, introduced in the 2001-04 business plan, will replace a previous measure, "Percentage of eligible applicants receiving the Alberta Seniors Benefit". The new measure is a better indicator of the Alberta Seniors Benefit (ASB) program's overall success.

² All Albertans automatically receive an ASB program application package three months before their 65th birthday or when they move to Alberta and apply for health insurance. Development of the performance measure has entailed developing a systematic way to follow up on seniors who have not applied for ASB to discover their intentions, and deriving a measure of "opportunity to apply" based on information obtained during follow-up. Preliminary data gathering during 2001 and 2002 provided a basis for developing a systematic methodology. Starting April 2003, this methodology entails mailing an information sheet and business reply mail card to all seniors who have not applied for benefits, asking them whether or not they intend to apply; they are also given the option of receiving a new application form.

While every attempt will be made to follow-up by telephone with those seniors who do not return the completed business reply mail card, the validity of the results will depend on the number of households contacted.

**Goal 1.2:
Seniors and their families have access to information and educational material about programs, services, and initiatives that are designed to enhance their well being.**

To make informed decisions on matters of importance to their well being, seniors and their families need to have access to accurate, up-to-date, and relevant information about programs, services and initiatives provided by their governments and within their communities.

Alberta Seniors provides information services to the public through telephone access, letters, the Alberta Seniors website, <http://www.seniors.gov.ab.ca/>, regional Seniors Information Services Offices, the *Programs and Services for Seniors* booklet, and the Seniors Services Workshop.

Keeping seniors, their families and service providers well-informed about government and community programs and resources

In 2002-03, the ministry received 181,192 recorded telephone calls, exceeding the total of 132,522 calls in 2001-02. In addition to providing information on the Alberta Seniors Benefit and Special Needs Assistance for Seniors programs, ministry staff responded to questions about federal programs and other provincial programs, and provided referrals to community-based agencies.

The Seniors Information Services Offices provided assistance to 40,095 clients in person, by telephone and through home visits, compared to the 35,894 clients served in 2001-02. Seniors Information Services Offices also hosted the 2002 Seniors Services Workshop, providing information on seniors' programs and services to 225 participants from 73 municipalities.

Supports Government of Alberta Goals 4 and 5:

Goal 4: Albertans will be independent

Goal 5: Albertans unable to provide for their basic needs will receive help

More than 50,000 copies of the *Programs and Services for Seniors* booklet were distributed to individuals and organizations across the province. Updated each year, the booklet provides clear and accurate information on government and selected community programs that are of benefit to seniors. Since many service providers, support workers and seniors now access this information through the ministry's website, approximately 55,000 fewer copies of the booklet were distributed in 2002-03 than in 2001-02.

Other resources published to keep the public informed include a quick reference *Fact Sheet* providing an overview of provincial and federal programs for seniors in Alberta, and the *Directory of Seniors' Organizations in Alberta*.

In 2002-03, the Alberta Seniors website, <http://www.seniors.gov.ab.ca/>, received 802,260 visits, approximately twice the number recorded for 2001-02. Ministry documents such as the *Programs and Services for Seniors* booklet, the *Saying Farewell* handbook, and the *Directory of Seniors' Organizations in Alberta* are available in PDF format to view and print.

Helping to inform and educate the public on issues of importance to seniors' well being

For 2002-03, the Seniors Fraud Awareness Committee developed four new fact sheets to add to the multimedia fraud awareness information package previously developed by the seniors fraud awareness campaign, *If in Doubt, Check it Out*. These fact sheets provided information on travel clubs, shopping on-line, identity theft, and home invasion protection. The Seniors Fraud Awareness Committee, which Alberta Seniors chaired, took a lead role in the development of this campaign, which is designed to educate seniors and caregivers through the information package. The package originally focused on the five most prevalent types of fraud: home renovation fraud, investment fraud, telemarketing fraud, and financial abuse. The new package was presented to the media and to provincial information workers at the Seniors Services Workshop in September 2002.

The ministry worked with Stony Plain Family and Community Support Services on *Saying Farewell: A Helpful Guide with Information and Forms to Assist You Through the Death and Dying Process*. Since its first printing in October 2002, over 5,500 copies have been distributed.

PERFORMANCE MEASURE

Measure: Satisfaction of seniors with information provided

This measure is a means of verifying the quality of information and service provided to seniors by the ministry through the telephone, regional Seniors Information Services Offices, and the *Programs and Services for Seniors* information booklet. These information sources are designed to help seniors become well-informed about programs and services for which they may be eligible and which contribute to their independence and well-being.

Percentage of clients satisfied with information provided³

	2001-02 %	2002-03 %	Target %
Seniors Information Line	90.4	90.7	90.0
Seniors Information Services Offices	95.2	94.4	90.0
<i>Programs and Services for Seniors</i> booklet	91.3	90.7	90.0

Source: Alberta Seniors, Seniors Services Division

³ Three separate surveys are conducted of telephone access clients, callers and visitors to Seniors Information Services Offices, and recipients of the *Programs and Services for Seniors* booklet. Satisfaction data for telephone access and Seniors Information Services Offices were collected through telephone surveys of randomly selected clients who had contacted the ministry on the previous day. The surveys were conducted during two-week periods in May and August 2002, and included questions about courtesy, knowledge, and promptness of service, as well overall satisfaction with information provided.

Satisfaction data for the *Programs and Services for Seniors* booklet were gathered from completed and returned self-administered questionnaires that were included with the booklet when it was mailed.

For all three surveys, the top two categories of a six-point scale, “very satisfied” and “satisfied”, were combined for an overall rating of satisfaction.

Analysis

Survey results indicate that 90.7 per cent of clients surveyed who had contacted the department by telephone were satisfied overall with the service provided, based on 397 responses to the question on overall satisfaction. For clients visiting the Seniors Information Services Offices, survey results indicate a 94.4 per cent satisfaction rate, based on 213 responses to the question on overall satisfaction.⁴ Of the 204 clients⁵ responding to the *Programs and Services for Seniors* booklet questionnaire, 90.7 per cent were satisfied overall.

Satisfaction with Alberta Seniors information services to seniors remained high and exceeded the target of 90 per cent. The 90 per cent target will remain in place for at least one more year to allow time for a pattern to be established.

The ministry endeavours to maintain a high level of validity and reliability of the results; however, there are some factors that cannot be fully controlled in these surveys. One such factor is the need to call a client within one day of contact with the department to ensure that events surrounding the contact are accurately recalled. Successful call-back requires that the client be at home and available at the time of the call.

A successful telephone interview is also dependent on a senior's ability to hear well over the telephone. In these situations, the interviewer must be prepared to take time and care to ensure that questions are posed clearly and are properly understood by the respondent.

In the case of questionnaires provided with the *Programs and Services for Seniors* booklet, respondents to this questionnaire are a self-selected, rather than a random, sample. They are required to pay for the questionnaire's return postage, and this may influence the number of surveys returned.

⁴ These numbers represent 4.4 per cent of clients contacting the Seniors Information Line, and 6.5 per cent of clients contacting regional Seniors Services Offices during the two two-week periods of the surveys, a total of 5 per cent of all telephone and in-person client contacts.

⁵ The 204 responses to this survey contrast with 868 responses received in 2001-02. The decline was due to a delay in the release of the booklet following changes in government programs, resulting in responses being received over an eight-month period only.

CORE BUSINESS 2: SUPPORT PROVISION AND MANAGEMENT OF SENIORS, FAMILY AND SPECIAL PURPOSE HOUSING

Goal 2.1:

Provincially-owned and -supported housing to meet the basic needs of low-income families and individuals, seniors and persons with special needs is effectively managed and coordinated.

Provincially-owned or -supported housing, operated by municipalities and community-based housing providers consists of units designed for seniors, low-income families and individuals, and persons with special needs who meet certain eligibility criteria. Seniors lodges provide meals, laundry and other services in addition to accommodation.

Alberta Seniors partners with the federal government, through the Canada Mortgage and Housing Corporation, to support the costs of maintaining the housing portfolio. The ministry also provides rent supplements, which reduce the cost of renting units, primarily in the private market.

Using the 2002 Client Profile Survey, the ministry estimated that approximately 24,000 seniors, 37,000 family housing residents, 1,500 persons with special needs and 1,300 rural and Native residents were served by the subsidized housing operated by community based housing operators.

Supports Government of Alberta Goals 4 and 5:

Goal 4: Albertans will be independent

Goal 5: Albertans unable to provide for their basic needs will receive help

Developing better ways to manage subsidized housing

During 2002-03, the Wood Buffalo Housing and Development Corporation assumed responsibility for all community housing in the Regional Municipality of Wood Buffalo.

Following a review of funding models and consultation with the Alberta Senior Citizens' Housing Association, the ministry established a set of principles for a new funding model for the Lodge Assistance Program, which will target assistance to those most in need, and recognize the higher costs of small facilities. The model reallocates grant funding within the existing program budget. The new funding formula (due for implementation in July 2003) targets the grant to low- and moderate-income seniors (defined as those seniors who are eligible for a cash benefit or health care premium exemption through the Alberta Seniors Benefit program). The grant will continue to be paid directly to lodge operators. As well, since smaller facilities are significantly more costly to operate, an additional grant will be provided for existing facilities with 33 or fewer units.

PERFORMANCE MEASURE

Measure: Satisfaction of housing clients with quality of accommodation and, where appropriate, services provided

This measure assesses the satisfaction of residents living in seniors' lodges and self-contained housing, and in the community housing component of family housing. It provides a means of verifying that the residents of provincially-owned or -supported subsidized housing are receiving safe, adequate, suitable and affordable housing that is properly managed and maintained.

Satisfaction of housing clients with quality of accommodation and, where appropriate, services provided^{6 7}

	2000-01 %	2001-02 %	2002-03 %	Target %
• Seniors lodge clients	91.5	87.2	90.8	93.0
• Self-contained housing clients	90.8	86.7	92.0	93.0
• Family and special purpose housing clients	78.7	76.5	77.5	80.0

Source: Alberta Seniors, Housing Services Division, Housing Satisfaction Research Study, 2003.

⁶ The intent of this survey is to measure satisfaction of residents of the community housing component of the family housing portfolio, in addition to the seniors self-contained and lodge programs. The survey is limited to these three programs, which comprise the bulk of our housing portfolio and are administered by management bodies. The survey is not intended to measure satisfaction with special purpose (or other) housing, which is not administered by management bodies. In the 2003-06 business plan, the title of this measure has been changed to specify "family housing, seniors lodges and self-contained housing" only.

⁷ Satisfaction was determined through a survey conducted for Housing Services Division by a private research company. A random sample of clients from the ministry's housing programs was surveyed by telephone about their overall satisfaction with the quality of their accommodation. Approximately 1,200 telephone interviews (approximately 400 for each of the three groups) were completed with residents of senior citizens' self-contained housing, senior citizens' lodges and community housing. The survey also measured a number of variables to assess the quality of accommodation, including overall condition, safety and affordability, and the services provided by the housing management body. The results from the top two categories of a six-point rating scale, "very satisfied" and "satisfied", were combined to obtain an overall rating of satisfaction. The research was conducted in February and March 2003 over a two-week period. Results based on a sample size of 400 are accurate within +/- 4.9 per cent, 19 times out of 20.

Analysis

Survey results indicate that 90.8 per cent of lodge residents and 92.0 per cent of self-contained housing residents were satisfied overall with their accommodation, based on 401 and 402 responses respectively to each survey. For community housing clients, 77.5 per cent of residents surveyed were satisfied overall with their accommodation, based on 401 responses provided.

This is the third year this survey of housing residents has been conducted, using the same methodology, questionnaire and rating scale. Reported satisfaction levels for 2002-03 are somewhat higher than in 2001-02, when 87.2 per cent of lodge residents, 86.7 per cent of self-contained housing residents, and 76.5 per cent of community housing residents reported overall satisfaction. The results for 2002-03 are closer to the reported satisfaction levels of 2000-01, when 91.5 per cent of lodge residents, 90.8 per cent of self-contained housing residents, and 78.7 per cent of community housing residents reported overall satisfaction. However, the differences among the three years' results do not reach statistical significance.⁸

The ministry will continue to work towards the targets set for these measures (93 per cent overall satisfaction for seniors housing residents, and 80 per cent for family housing) as it strives to ensure that provincially-owned and -operated housing is efficiently managed and well-maintained. Maintenance, affordability and safety are all areas within the ministry's ability to influence and are all related to satisfaction levels.

As with all satisfaction surveys, there are certain external factors that may affect the results of these measures and these are, for the most part, beyond the control of the ministry. These include issues that residents may have with their neighbours or the neighbourhood, and the variability and subjective nature of satisfaction.

⁸ Due to sampling error, when comparing results between two or more years, differences of more than 7% would be considered statistically significant at the 95% confidence level. Differences of less than 7% may or may not be significant, depending on the level of consensus of results to a question.

Goal 2.2:**Seniors, low-income families and individuals, and persons with special needs have access to a range of housing appropriate to their needs at reasonable cost.**

Housing for low-income families and individuals, and persons with special needs, as well as supportive housing for low-income seniors, need to be addressed. The ministry's strategic approach to developing a response to these housing needs is through the pursuit of partnerships with other ministries, other levels of government and with community-based organizations.

Working in partnership to facilitate planning and development of low cost and supportive housing

New low-cost seniors housing funded by the Seniors Supportive Housing Incentive Program/Healthy Aging Partnership Initiative continued to be completed by community-based organizations. In 2002-03, 321 new units came on stream through this program.

A total of 215 low-income disabled Albertans received grant approvals from the Home Adaptation Program to assist in completing wheelchair modifications to their homes. The total expenditure for this program in 2002-03 was \$919,000.

The ministry worked with the major urban municipalities in assessing and addressing their housing needs. Alberta's major cities completed, and in some cases began implementing, community housing initiatives.

Supports Government of Alberta Goals 4 and 5:

Goal 4: Albertans will be independent

Goal 5: Albertans unable to provide for their basic needs will receive help

Creating more affordable housing in areas of greatest need

Following the signing on June 24, 2002 of the new Canada-Alberta Affordable Housing Program Agreement, Alberta Seniors announced a commitment of \$8.5 million for 2002-03 to match Canada Mortgage and Housing Corporation's \$8.5 million for affordable housing in Alberta's high-growth, high-need communities.

Projects receiving funding from the Canada-Alberta Affordable Housing Program were located in Calgary (\$9.15 million) Edmonton (\$3.3 million), Fort McMurray (\$1.875 million), Red Deer (\$975,000), Grande Prairie (\$950,000), and the rural communities of Conklin and Janvier (\$750,000). This funding will provide for more than 420 new housing units in these high-need locations.

The ministry continued to support the development of the Edgewater Court facility in Fort McMurray, which was designed to ease the shortage of affordable housing in the region. In 2002-03, a further 55 units were added to the 120 units that were completed in 2001-02. Capital grants totaling \$1.65 million were provided for this project in 2002-03. The ministry also initiated the development of two six-plexes as affordable housing. These facilities have helped to increase the number of affordable housing units in Fort McMurray and have provided some relief to a very high-cost, low-vacancy housing market.

As well, the ministry provided 17 acres of land to the Wood Buffalo Housing and Development Corporation for the construction of affordable housing.

Addressing homelessness

The ministry continued to dedicate resources towards addressing housing for homeless people. Through the Provincial Homelessness Initiative, the ministry committed \$3 million annually from 2000-01 to 2002-03 for Alberta's seven major urban centres. This investment has resulted in contributions of over \$81.6 million from municipalities, private and non-profit sectors, and community organizations. In addition, \$50 million in federal funds have been contributed from the National Homelessness Initiative over a period of three years.

As a result of these investment partnerships, 1,100 emergency, transitional, long-term supportive and special purpose housing units have been created by community organizations across the province, with an additional 800 units under development.

The ministry was awarded a silver Premier's Award of Excellence in recognition of its achievements in developing a strategy to help communities address the needs of homeless people in Alberta.

PERFORMANCE MEASURE

A measure for Goal 2.2 is to be developed. The ministry has considered a number of different approaches to measuring this goal, including potential methodologies for measuring the need for low-cost housing. However, the ministry's policy directions concerning housing have shifted toward encouraging and supporting the development of community-based solutions for housing for lower-income families and individuals that are based on local needs. Measurement efforts will be directed towards the department's performance in encouraging the development and implementation of these plans, rather than in the direct collection and analysis of data on need.

CORE BUSINESS 3: PROVIDE PLANNING AND POLICY DEVELOPMENT FOR SENIORS AND HOUSING

Supports Government of Alberta Goals 1, 4 and 5:

Goal 1: Albertans will be healthy

Goal 4: Albertans will be independent

Goal 5: Albertans unable to provide for their basic needs will receive help

Goal 3.1: Government policies and plans effectively anticipate and address the needs of seniors and Albertans in need of housing supports.

Alberta Seniors provides a central coordinating and leadership structure within government on issues relating to seniors and housing. The ministry monitors social, demographic, economic and political trends provincially, nationally and globally, and analyzes them for their potential to impact seniors, older Albertans and people in need of low-cost housing. The ministry collaborates with other ministries, other levels of government and stakeholders on projects and initiatives relating to seniors, the aging population, and persons in need of housing.

Supporting the Cross Ministry Health Sustainability Initiative

In 2002-03, the Government of Alberta announced the cross ministry Health Sustainability Initiative. The purpose of this initiative is to enhance the sustainability of the health care system now and in the future by strengthening collaboration and coordination across ministries. Alberta Seniors, together with Alberta Health and Wellness and Alberta Finance, co-championed the Health Sustainability Initiative.

The Health Sustainability Initiative facilitated the advancement of strategies and actions to promote supportive living that were identified through the cross ministry Seniors Policy Initiative in 2001-02. These included the development of a Supportive Living Framework and an inventory of barriers limiting the expansion of supportive living. The framework outlines a vision for the future of supportive living, and promotes a common understanding of the different types of supportive living to provide clarity regarding roles and responsibilities for government, regional health authorities, housing operators and others. Seniors and their families will be able to use the information to help them make decisions about what option will best meet their needs.

Key health related initiatives identified through the Seniors Policy Initiative, and recommendations relating to healthy aging and seniors' wellness outlined by the Premier's Advisory Committee on Health, were further developed by the Health Sustainability Initiative.

One of the outcomes of these initiatives was the *Healthy Aging and Seniors Wellness Strategic Framework 2002-2012*, which is focused on enabling seniors to be healthier to a more advanced age. Regional health authorities, seniors and community organizations will be encouraged to use this framework as a tool in planning initiatives and activities focused on healthy aging. Alberta Seniors co-chaired the task group that finalized and distributed this document.

The ministry contributed to the *Healthy Alberta Promotion and Prevention Policy Framework*, which focused on establishing 10-year health objectives, targets and strategies to improve the health of Albertans. As well, the ministry worked with Alberta Health and Wellness to develop proposals for non-financial incentives to encourage and sustain healthy behaviours among Albertans.

Responding to emerging seniors and housing issues

As part of its ongoing work in gathering and analyzing key socio-economic, demographic and health information on seniors, the ministry published and posted on the ministry website a fact sheet on seniors. *Fact Sheet: A Portrait of Alberta Seniors* provides information on Alberta's seniors, focusing on demographics, housing, income, ethnicity, health status, and activities.

In March 2003, the ministry committed to helping seniors on low fixed incomes to deal with the spike in utility prices that came during a particularly cold period of winter. As a temporary measure, assistance with the increase to the cost of utilities became an allowable expense under the Special Needs Assistance for Seniors program.

Outcomes of initiatives developed under the 2001-02 cross ministry Seniors Policy Initiative continued to guide and inform much of the developmental work undertaken by the ministry. One result was the completion and publication in May 2002 of *Current and Future Roles and Needs of Seniors' Centres in Alberta*. This study was supported by Alberta Seniors, and conducted through a partnership of the Seniors Advisory Council for Alberta and the Alberta Council on Aging. It identified the important role that seniors' centres play in the continuum of services for seniors, and made recommendations concerning their sustainability.

Many low-income seniors have had difficulty accessing affordable dental care through private insurance. Alberta Seniors has responded to this issue by developing a landmark agreement with the University of Alberta Department of Dentistry and Dental Hygiene. Under this agreement, the ministry will provide funding to the university department for the provision of dental services to low-income seniors. The agreement was developed for implementation on April 1, 2003.

Working in partnership with provincial, territorial and federal colleagues

In June, 2002, the minister participated in the federal/provincial/territorial Ministers responsible for Seniors meeting in Toronto. For this meeting, the ministry contributed to initiatives relating to planning for Canada's aging population, healthy aging and seniors wellness, abuse of older adults, and family and informal caregiving.

In October 2002, ministry officials participated in a federal/provincial/territorial meeting of Deputy Ministers responsible for Housing. At these meetings, Alberta Seniors and Canada Mortgage and Housing Corporation secured the endorsement of the terms of reference for a national Supportive Housing Working Group, of which they are co-chairs. The working group will develop an inventory of models, terminology, policies and practices, and key studies from across the country with particular emphasis on the range of departments and agencies involved in supportive housing.

PERFORMANCE MEASURE

Measure: Satisfaction of departments and agencies with the ministry's leadership and collaboration, and with the information, advice and analysis received

The ministry's collaborative activities with other government departments and agencies assist in policy and program research and analysis that take into account the needs of seniors and of Albertans in need of housing supports. These activities include membership on joint working groups and initiatives, and the provision of information, advice and analysis of data on seniors and housing. Satisfaction of government departments and agencies is a measure of the quality of the ministry's services in these areas.

Analysis⁹

Results of a satisfaction survey of the ministry's key stakeholders indicate that 40 (representing 80 per cent) respondents were satisfied overall with services provided. Six respondents were slightly satisfied, two were slightly dissatisfied, one was dissatisfied, and one was very dissatisfied.¹⁰

The target for this measure for 2002-03 was 90 per cent "very satisfied" or "satisfied". The ministry will continue to work towards this target in the coming years, with the 2002-03 results serving as a baseline.¹¹

⁹ Satisfaction data were gathered by means of a telephone survey of 70 stakeholders. To select the list of survey participants, ministry staff were asked to review their files and projects from 2002-03 to identify all key stakeholders who met predetermined criteria for inclusion. The final list of stakeholders included Alberta government employees, employees of other provincial governments and the federal government, and representatives of organizations and agencies that work in the areas of seniors services or housing. The survey was conducted in March, 2003 by a private research company. Respondents were asked to rate their satisfaction with the courtesy, accessibility, responsiveness, knowledge and leadership of staff, as well as the quality, accuracy, completeness and timeliness of information received. Respondents were also asked to rate their overall satisfaction with the services provided.

A total of 51 questionnaires were completed, with 50 responses to the question on overall satisfaction. The results from the top two categories of a six-point rating scale, "very satisfied" and "satisfied", were combined to obtain an overall rating of satisfaction.

This is the fifth year a stakeholder satisfaction survey has been conducted. In 2002-03, significant changes to the methodology included switching from an in-house mailed survey to a telephone survey conducted by a private research company, and the inclusion, for the first time, of family and special purpose housing stakeholders. The decision to contract-out the survey was made to address concerns about the low response rate and confidentiality. Although the intent of the survey questions remained similar, the format and wording was changed to simplify the questionnaire and adapt it for telephone use. Because of the change in methodology, comparisons with previous years' results are not valid.

¹⁰Source: Alberta Seniors, 2002-2003 Satisfaction Survey, Final Report

¹¹It should be noted that the relatively small size of the population surveyed influences the validity of the results. Small populations tend to magnify differences among respondents, which may result in exaggerated rather than truly representative results.

CORPORATE STRATEGIES

Improving the efficiency, effectiveness and safety of Alberta Seniors work environment

In addition to activities directed towards the three core businesses above, the ministry engaged in a number of corporate activities to improve the efficiency, effectiveness and safety of the working environment.

In the area of human resource planning, the ministry updated the Corporate Human Resource Plan, and initiated the updating of the performance appraisal system to meet the specific needs of Alberta Seniors staff. Awards were provided to staff reaching service milestones of between five and 35 years inclusive.

Desktop computers were upgraded as part of the “evergreening” strategy of information technology, and the ministry continued strengthening its computer network infrastructure.

The ministry supports the Government of Alberta’s corporate concept in addressing future information and communication technology (ICT) needs. The ministry’s Chief Information Officer is a member of the cross ministry Executive Sub-Group that is providing guidance and expertise on ministry business requirements for developing the business case for this approach.

An accommodation plan was executed to consolidate ministry employees in a more effective working environment. Improvements were made to the file storage facilities and staff working with files were integrated into a single unit, improving their working efficiency, and providing a work area designed to support the demands of effective application processing support and file management. The Deputy Minister’s office and Communications office were moved to provide more appropriate office space.

As part of its Business Resumption planning, the ministry developed a Business Resumption Policy. The plan and policy will enable ministry staff to resume delivery of essential services quickly and efficiently in the event of a disruption of normal business operations.

As part of the government-wide capital planning initiative, the Project Prioritization Task Group reviewed and prioritized 100 capital projects, resulting in provincial funding being allocated to the Canada-Alberta Affordable Housing Program.

A component of the capital planning initiative, a common evaluation model for tracking the condition of buildings on a consistent basis, was tested and is near completion.

LOOKING FORWARD

Socio-economic and demographic influences

Changes in the social and economic environment of the province may affect the Ministry of Seniors' performance and results in the future.

One of the ministry's core businesses is to assist low-income seniors who are unable to meet their basic needs. Although there has been a gradual trend toward greater financial independence among seniors over the last few decades, it is uncertain whether this will continue. Continuing low interest and investment return rates, and a slow recovery of world markets have a negative impact on seniors' incomes. This could result in an increasing, rather than decreasing, need for financial assistance, especially as the seniors' population is expected to increase significantly over the next decade. Additionally, potential changes to federal and provincial programs and new directions in health services provision may have a cumulative impact on seniors' relatively fixed incomes.

While Alberta's strong economic growth over the last few years has contributed to the province's overall prosperity, it has also resulted in a shortage of low-cost and affordable housing, a decline in availability of lower cost housing for low-income seniors, and an increase in the number of homeless people, especially in major urban centres and high-growth areas. The ministry's success in addressing these housing issues is tied to the capacity of local community organizations to build and manage housing that is targeted to the needs of low-income Albertans. Assuming that housing and rental costs, along with demand for low-cost housing, continue to rise, the ministry will be challenged to develop effective partnerships with housing organizations based on the availability of capital incentives, or the capacity of organizations to generate capital.

Internal changes are anticipated as the ministry's businesses continue to evolve and grow. Effective April 2003, the ministry will assume responsibility for homeless shelters, including the Gunn Centre, from Alberta Human Resources and Employment. As a result, the ministry expects to provide more effective and coordinated housing services.

In addition, the transfer of the Office of the Public Guardian to Alberta Seniors from Alberta Human Resources and Employment, to be effective April 2003, will significantly expand the ministry's mandate. Approximately 50 per cent of clients under public or private guardianship in Alberta are seniors, and the remainder are between the ages of 18 and 64. The ministry anticipates new challenges and opportunities for delivering quality services to dependent adults and other clients of the Office of the Public Guardian.

Responding to changing priorities

The ministry's business plan identifies activities planned for a period of three years. However, plans and priorities sometimes change to respond to new business and policy directions or changing external circumstances. Some business plan activities have been deferred to later years, while others have been re-evaluated as the ministry's strategic directions have evolved.

For example, the development of a benchmark measure for "sufficient retirement income" has been put on hold, pending the accumulation of more substantive trend data on seniors' incomes.

Resources did not support a review of the special purpose housing portfolio or the pursuit of additional one-time, targeted funding to community housing organizations to increase the supply of low-cost seniors' supportive housing. These initiatives will be incorporated into subsequent years of the business planning cycle as required.

The development of more flexible working arrangements with Canada Mortgage and Housing Corporation has minimized the benefit of negotiating a new social housing agreement as previously planned. Instead, the ministry strengthened its focus on facilitating the creation of community-based housing corporations to manage local lower cost housing.

As a consequence, the planned review of the *Alberta Housing Act* was re-evaluated. In place of a full review, in the absence of a new Canada Mortgage and Housing Corporation agreement, the necessary adjustments to the *Act* to reflect the focus on community-based housing corporations can be achieved through miscellaneous amendments.

FINANCIAL PERFORMANCE HIGHLIGHTS

The financial results for the Ministry of Seniors for the year ended March 31, 2003 include the activities of the Department of Seniors and the Alberta Social Housing Corporation. More detailed information can be found in the attached financial statements.

The consolidated financial results for 2002-2003 show that the Ministry of Seniors spent \$365.9 million against an authorized budget of \$366.6 million.

In 2002-03, \$344.8 million, or 94 per cent of ministry expenditures were spent in the core functions of the ministry. These included direct assistance to individuals and organizations in the form of grants, and debt servicing costs for the housing units used in delivering our programs.

Grant expenditures totaled \$275.7 million, with \$179.1 million of the grant expenditures being directed to provide financial assistance to eligible lower-income seniors through programs like Alberta Seniors Benefit, and Special Needs Assistance for Seniors. The remaining grant payments were directed toward housing programs. The ministry expended \$96.6 million for grants to local housing providers through both the department and the Alberta Social Housing Corporation. Of this amount, \$17 million involved expenditures under the Canada-Alberta Affordable Housing Program Agreement, which will allow the development of over 420 new affordable housing units.

Summary of Ministry Expenses - \$365.9 million

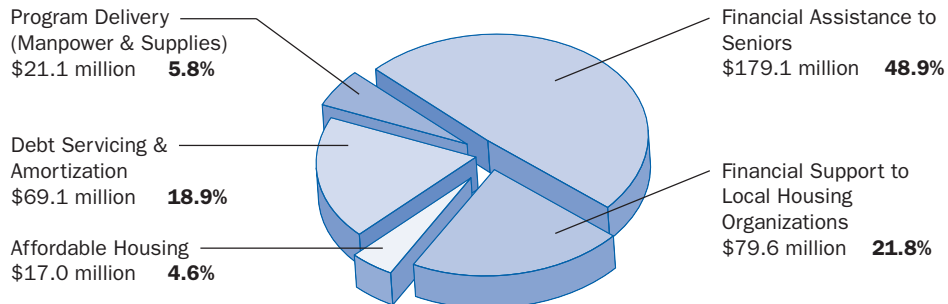

Other expenses for the ministry consisted of \$69.1 million for interest charges for long term debt and amortization relating to the housing portfolio. Manpower, supplies, and service costs to deliver ministry programs totaled \$21.1 million, and made up less than 6 per cent of ministry expenditures.

FINANCIAL INFORMATION

Index of Financial Statements

Ministry of Seniors	53
Department of Seniors	79
Alberta Social Housing Corporation	101

