

June 2005



Alberta Energy Research Institute

2004 - 05 Annual Report

Len Bolger, *Co-Chair, AERI Board*
Mel Knight, *MLA Co-Chair, AERI Board*
Eddy Isaacs, *Managing Director*



AERI Staff

Dr. Eddy Isaacs

Managing Director

Dr. Ted Cyr

Special Advisor, Energy Projects

Dr. Duke du Plessis,

Senior Research Manager, Clean Carbon/Coal

Dr. Catherine Laureshen

Senior Research Manager, Upgrading

Douglas Komery

Senior Research Manager, Oil Sands

Les Little

Senior Research Manager, Recovery

Richard Nelson

Senior Research Manager, Alternate & Renewable Energy

Dr. Surindar Singh

Senior Manager, Planning and Evaluations

Alice Hedges

Planning and Operations

Marta Bor

Administrative Support, Edmonton

Susan Emilsson

Administrative Support, Calgary

Donna Kostuik

Administrative Support, Calgary

June 30, 2005

Hon. Victor Doerksen
Minister, Alberta Innovation & Science
402 Legislature Building
10800 97th Avenue
Edmonton, AB, T5K 2B6

Dear Minister Doerksen:

Re: Alberta Energy Research Institute 2004-05 Annual Report

In accordance with Section 27 of the Alberta Science and Research Authority Act, we are pleased to submit to you the 2004-05 Annual Report of the Alberta Energy Research Institute (AERI).

The national launch of the Energy Innovation Network in March 2005 marked a major milestone in the significant progress that has been made to implement the Alberta Energy Innovation Strategy. The strategy was developed in 2001 by the AERI Board, the AERI staff and with support from industry stakeholders and has had an enormous impact on the energy research and innovation agenda across the country and increasingly among international partners.

Alberta has vast oil sands resources and when these are combined with the province's coal and natural gas resources, we have one of the largest supplies of hydrocarbons in the world. While the potential for Alberta to be the premier supplier of energy to North America and the world has never been greater, the technological challenges facing the energy industry in Alberta and Canada have also never been greater. Conventional oil and gas resources have peaked and are declining and finding replacement alternatives will be challenging and requires investment in high-risk unconventional oil sands and coal bed methane resources. The challenges include the need to improve competitiveness affected by the rising cost of energy, improved recovery technology from oil sands, conventional oil and unconventional gas, maximizing the value of our world-class resources and moving aggressively towards cleaner coal and hydrocarbon utilization, alternate energy and sustainable environmental performance. It is important that we address these challenges immediately.

The AERI Board and staff have accepted the challenge from you on behalf of the Government of Alberta and ASRA, to provide visionary leadership to shape our energy future and promote sustained investments in energy research and innovation. With government support we will continue to search for risk sharing mechanisms with industry for higher cost risk and costly demonstration and commercialization of technology. The Innovative Energy Technology Program developed for in situ production of conventional and unconventional resources by the Department of Energy and supported by AERI is a good example - and we need more good examples.

The Annual Report provides a summary and analysis of the 2004-05 activities carried out by the talented AERI team.

Thank you for your continued support of AERI and our important endeavors. If you have questions or comments concerning this report, please contact Dr. Eddy Isaacs, Managing Director, Alberta Energy Research Institute at (403) 297-5219.

Respectfully submitted,

Original Signed By

LEN BOLGER
Co-Chair, AERI Board

Original Signed By

MEL KNIGHT, MLA
Co-Chair, AERI Board

I. Responding to the Global Energy Challenge

Canada and the Global Energy Shifts

In the past decade, global energy demand has increased by 20% and is projected to increase by an additional 50% by 2030. The world continues to rely heavily on traditional forms of energy. Though renewable resources are expected to grow, they cannot displace fossil fuels as the over-riding source of energy in this time frame. Gas consumption will double between 2000 and 2030 because of its cost competitiveness, ample availability and environmental advantages. Oil will remain the largest fuel source with demand increasing by 1.6% per year. This growth comes at a time when the supply from relatively cheap conventional sources is declining and reserves are not being replaced with new discoveries.

The world has more than double the heavy oil and bitumen than it does conventional oil. It is estimated there are six trillion barrels of heavy oil and bitumen in place worldwide, of which potentially 900 billion barrels are commercially exploitable with existing technology. Canada has 175 billion barrels of proven bitumen reserves, making it second only to Saudi Arabia in proven oil reserves in the world.

Canada is the fifth largest energy producer in the world when hydroelectric, nuclear energy and fossil fuel production are taken into account and is a net exporter of energy. This export of energy accounts for from six to ten percent of Canada's Gross Domestic Product (GDP).

Canada also has vast coal resources. Nova Scotia, Saskatchewan and Alberta currently rely on coal for 70% of their electricity needs. In Ontario, a province that relies on coal for 25% of its electrical power, the current government has committed to phasing out coal-fired electricity generation within three years. The lack of any obvious near-term solutions for filling the gap and meeting new demand has caused concerns among major industrial power consumers in Ontario.

Technology is being developed to produce electricity from coal and other low-value carbons with virtually no harm to the environment, and at the same time create new value-added products such as hydrogen, natural gas and fuels. The challenge now is to develop the technology required for converting Canadian feedstocks into robust, reliable, commercial products and applications.

Energy is important to Canada because it sustains manufacturing jobs in Ontario and Quebec, provides employment in Newfoundland and Nova Scotia and is a source of significant revenues that sustain our lifestyle across Canada. Our economies have been built on the presumption of relatively cheap and readily available energy. We are rapidly reaching an era where we would lose our global advantage to Europe and China and India – unless we are ready to act today.

Urgency for Energy Research and Innovation

There is a growing recognition that solutions to pressing global energy needs and the challenges described above emerge when we view the energy industry as one interconnected system. A good example of technology integration in the oil sands is the Opti-Nexen Long Lake project, which represents the future of Canadian oil sands expansion. This project uses Steam-Assisted Gravity Drainage (SAGD) technology to produce the bitumen, and no natural gas is consumed during the process to supply the high-energy demand for steam injection and upgrading.

To address the challenges of ensuring an abundant supply of environmentally responsible energy, we have promoted the establishment of an organization across Canada to implement an integrated energy innovation strategy. This collaborative initiative, known as EnergyINet, is being built on the premise that strategic investment in a balanced portfolio of energy innovation – with a focus on common technology platforms and points of leverage across the portfolio – has the greatest potential for economic, environmental, and societal returns. Given the rich diversity of resources available in Canada and in other parts of the world, and the need to maintain a competitive energy supply while ensuring environmental protection, the best investment strategy is one that focuses on a shift in the energy system from:

- Relying on conventional oil and gas recovery, to emerging unconventional sources such as oil sands and coal bed methane
- Conventional coal burning to virtually emission-free clean coal technology
- A relatively low to a much higher proportion of renewable and hydrogen energy options in the mix of energy production
- A focus on separate energy sources to an integrated energy system.

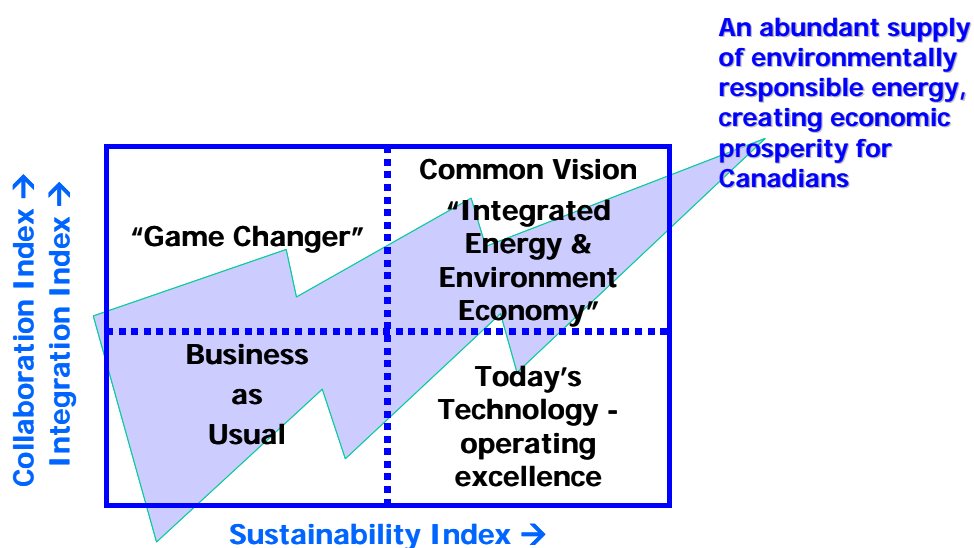

The strategy being implemented through EnergyINet addresses issues regarding the world's future energy economy. It highlights the need to combine innovation with government policies and actions. The path from concept to commercialization is long and arduous – fraught with dead ends, pitfalls and the lack of staying power. Even the most promising technologies take 15 to 25 years to commercialize. The best approach (proven in development of Alberta's oil sands) is government-industry partnership to share resources and expertise, lower risks and provide tools for Canada to become the world's leading supplier of clean energy in the 21st century.

"As the ethic and imperative of sustainability take deeper root worldwide, human ingenuity will turn increasingly to ways to produce and use energy more cleanly and efficiently; to eliminate toxins from our air, water and soil; and to build more sustainable communities. Here lie great new opportunities for the world economy. Canada's entrepreneurs must aim to be at the leading edge."

- Speech from the Throne, to open the first session of the thirty-eighth Parliament of Canada, October 5, 2004

II. Program Overview

AERI Strategy and EnergyINet

The Alberta Energy Research Institute (AERI) is an unincorporated board established under the *Alberta Science and Research Authority Act* and comprised of representatives from industry, business, academia and government. AERI provides strategic direction to position Alberta for the future in energy development and invests in innovation and technology to enhance the sustainable development of the province's abundant energy resources.

AERI's mandate involves research into all sources of energy of importance to Alberta aimed at creating commercial value. The intent is to centralize and focus all government-supported energy research and innovation to respond effectively to the opportunities and risks associated with global energy markets. Strategic investments in energy research, technology programs and innovation systems will ensure the use of existing and new energy resources to their fullest potential.

New technology is required to unlock the large remaining conventional energy reserves. With the right technologies, bitumen, coal and coal bed methane have hundreds of years of production remaining, but production of those reserves depends on finding effective solutions and the technologies that address the following:

- Production costs (steam generation) affected by rising cost of natural gas.

- The cost of hydrogen needed for upgrading of bitumen to higher valued products.
- Availability of natural gas liquids used as feedstock for the growing petrochemical sector.
- Bitumen and synthetic crude have market limitations and will lose value as additional production comes on stream.
- Addressing air emissions, land access, and water management issues is critical to ensuring continued “access to resources”.
- CO₂ emissions need to be addressed in the context of climate change.

Activities undertaken by AERI over the 2004-05 fiscal year support the directions established by ASRA, and also support the Alberta Innovation and Science 2004-07 Business Plan, GOAL 2: ***“To support energy research that will contribute to Alberta's sustained prosperity and quality of life.”***

Under AERI's leadership, the EnergyINet initiative has led to a fully integrated and collaborative research network. AERI has also worked to integrate projects across the research development continuum and ensure that fundamental research has a chance to move through to development and commercial implementation. The AERI staff has identified several key platform technologies that will link various innovation program areas.

Goals & Objectives

AERI has six program areas and eight strategic goals that guide its technology investment portfolio. As shown in the figure below, the strategic goals are:

- **Bitumen-derived Production:** Develop key technologies and innovation networks that will contribute significantly to the growth of production levels to three million barrels per day of heavy oil and bitumen by 2020.
- **Value of Bitumen-derived Products:** Support the development of the key technologies and innovation networks that will contribute significantly to the diversity, value and competitiveness of bitumen-derived products including fuels, chemicals and petrochemicals.
- **Greenhouse Gas Emissions:** Support the development of a number of key technologies and innovation networks that in total will achieve a 50% reduction (over the base year) in greenhouse gas emissions per unit of GDP by 2020.
- **Clean Coal/Carbon Technologies:** Support the adaptation and development of the key technologies that will be incorporated in a clean coal/carbon demonstration plant by 2010 and fully commercial plants by the year 2020.
- **Gas Recovery:** Support the development of a number of key technologies that will result in 15% of natural gas production coming from non-conventional sources.

- **Conventional Oil Recovery:** Support the development of a number of key technologies that will lead to a 20% increase in oil recovery through carbon dioxide-based and other enhanced recovery processes by 2020.
- **Alternate and Renewable Energy:** Support the demonstration and commercial application of a number of alternative energy production technologies in Alberta that will provide 15% of energy production by 2020.
- **Water Use in Energy Industry:** Support the development of a number of key technologies that will result in a 50% reduction in fresh water usage by the energy industry in Alberta by 2020.

Strategic Program Areas

In order to implement these goals, AERI uses the following matrix to guide development in its six strategic program areas.

Inputs Strategies	Enablers Innovation Capacity	Outputs Economic, Environmental and Social Impact
A1. Alberta Energy Innovation Strategy	B1. Energy Innovation Network	C1. Bitumen Upgrading Efficiency, Diversified Products and Environment
	B2. Policy and Business Drivers	C2. Clean Carbon/Coal Coal; Biomass; Heavy Liquids and Environment
	B3. Innovation Framework (Cross-cutting initiatives) <ul style="list-style-type: none"> ○ Capacity building ○ Global intelligence ○ Commercialization ○ Strategic communications 	C3. CO₂ Management CO ₂ Environment; CO ₂ Use & Disposal
		C4. Improved Recovery Conventional Oil; Natural Gas and Oil Sands
		C5. Alternate & Renewable Energy Hydrogen/ Fuel Cells; Bio-energy Geothermal energy
		C6. Water Management Cross-cutting Initiatives; Upgrading and Recovery

The six AERI strategic program areas are:

- Bitumen Upgrading
- Clean Carbon/Coal
- Carbon Dioxide Management
- Improved Recovery
- Alternate and Renewable Energy
- Water Management.

Performance Monitoring

AERI evaluates its progress by using a 16 cell ProGrid[®] Evaluation Matrix. The premise of the evaluation methodology is that Alberta's energy goals over the next 15 years will only be realized if substantive new technologies and innovations are put into place.

The plan identifies two desired future states, one to be achieved by 2012 (Future 1) and the other to be achieved by 2020 (Future 2). Attaining these future states will have huge economic, environmental and social benefits.

The 2003-04 AERI performance was rated on how well it met its objectives, and in a separate rating exercise, the degree to which this contributed to the Future 1 goals.

In the diagram below, the red line shows the progress of AERI initiatives made toward achieving their internal objectives, represented by the yellow area. In two of the 16 evaluation areas, initiative objectives were exceeded. There was major progress in seven other areas.

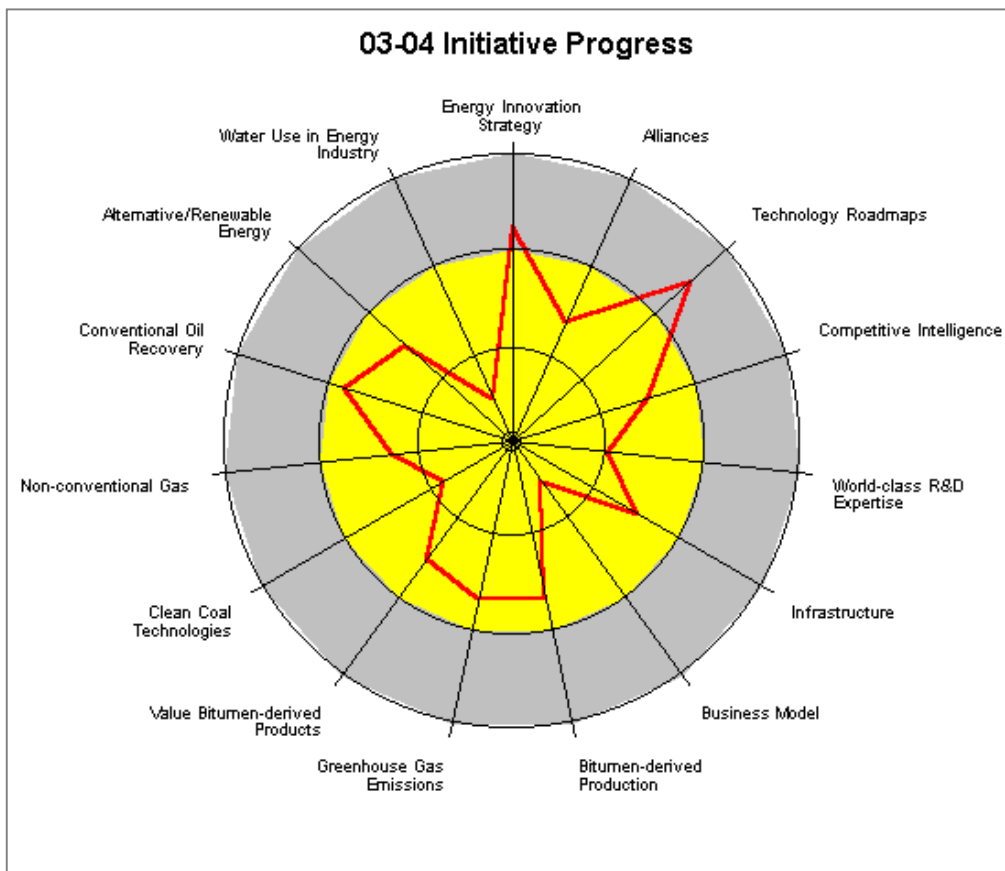

III. Clean Carbon/Coal Program

Alberta has an abundance of coal, coke, oil sands and refinery residues and biomass that could be converted to higher value products through new and improved gasification technologies. The goal of this program is to demonstrate that it is technologically feasible and commercially viable to:

- Produce electricity from coal and other low-value carbons with virtually no harm to the environment;
- Create a variety of new products from coal (“polygeneration”), including hydrogen, natural gas and raw materials (“feedstocks”) for the petrochemical industry.

Research, Technology & Innovation

During the past 20 years, gasification technology has advanced considerably and high-pressure entrained-flow gasifiers have shown a great deal of promise. Industry has also been leading the way in searching for clean coal technology produce electricity and other products from coal with virtually no air or carbon dioxide emissions. We’re close to finding a commercially viable solution in this area.

The basic technology, called “Integrated Gasification Combined Cycle” or IGCC, has been proven in field demonstrations. In this process, coal is converted into a syngas composed primarily of carbon monoxide and hydrogen. A high efficiency gas turbine burns the clean syngas to produce electricity. Exhaust heat from the gas turbine is recovered to produce steam to power traditional high-efficiency steam turbines. IGCC is the cleanest, most efficient means of producing electricity from coal.

AERI and the Canadian Clean Power Coalition (CCPC) representing Canada’s coal-fired power producers have been evaluating technologies for generating clean power from different Canadian coals, including the capture of CO₂. The aim is to facilitate the building of a demonstration plant, including polygeneration producing electricity, syngas for chemical production and hydrogen for upgrading and refining. The first phase of the work was completed and showed that it is feasible to capture CO₂ and make it available for enhanced oil recovery at reasonable prices. It also found significant enhanced oil recovery and CO₂ sequestration opportunities in western Canada.

AERI has identified critical technology gaps and formulated a balanced portfolio of projects, covering early-stage research to technology development and demonstration as shown below.

Clean Carbon/Coal program

Portfolio Balance

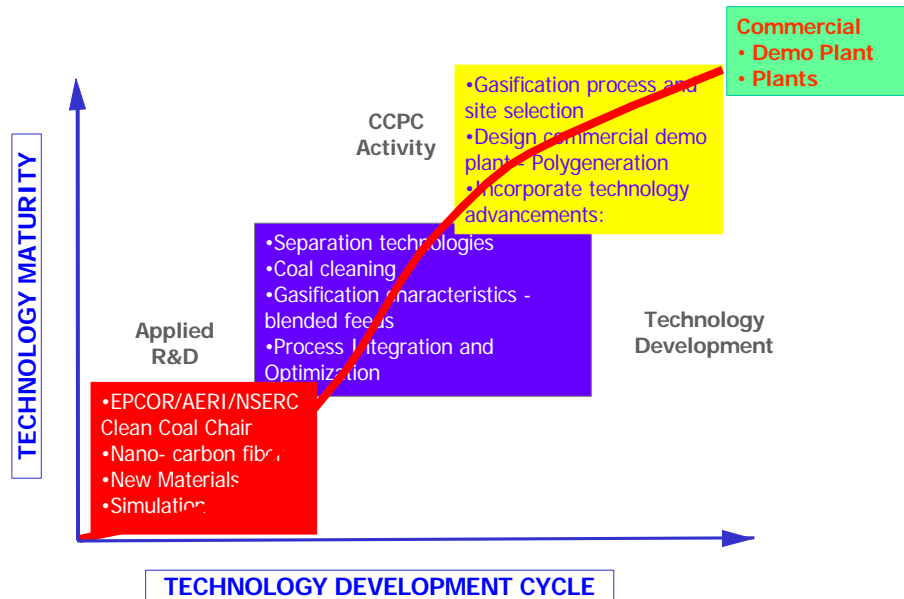

Program Vision

Working with industry and other government agencies, AERI has formulated the following vision: *Alberta will become a leader in adapting and integrating technology and knowledge for the effective utilization of coal and other low-value carbon fuels as an energy source for the production of electricity, heat and chemical feedstocks with zero or minimal environmental impacts on land, air and water.*

2004-05 Activities

A number of high-priority projects were developed, focusing on uniquely Alberta feedstocks such as sub-bituminous coals, oil sands coke and asphaltenes. In addition, biomass (including municipal solid wastes and forest residues) has been identified as an important feedstock for gasification.

The 2004-05 activities focused on:

- **Gasification of low-rank coals:** Technology adaptation to allow gasification of the sub-bituminous coal and lignite found in western Canada (existing technology is geared to bituminous coal).
- **Coal cleaning:** Technology to reduce the amount of sulphur and mercury in coal, and to remove minerals and moisture so that it's easier and less expensive to convert the coal to power.

- **Blended fuels:** Determining how much low-value oil sands or refinery coke can be mixed with coal to reduce the cost of the power produced.
- **Gasification tests with Alberta feedstocks:** Determine the gasification characteristics of different sub-bituminous coals, beneficiated coals, oil sands coke and asphaltenes, as well as blends of these feedstocks. The purpose is to determine the feeds and blends that would reduce the cost of gasifiers and increase the reliability of gasification plants.
- **Novel gasifiers:** More reliable and cost-effective technology to turn coal into gas.
- **New materials:** Stronger and thinner materials to replace the ceramic lining that contributes significantly to the cost of gasifiers, requires costly maintenance and associated outage time, and reduces the volume inside the gasifier.
- **Separation technology:** Technology to remove sulphur, CO₂ and particulate matter (dust) from what comes out of the gasifier at high temperatures, to improve the efficiency of the cycle. Also a new line of ion membrane separators capable of separating pure oxygen from air without the costly steps of refrigerating and liquefying the air.
- **Simulation modeling:** More sophisticated computerized modeling of how the many highly complicated chemical processes involved work together, making it possible to predict how changes (different coal quality, different amount of pressure) affect performance, and therefore to optimize processes without costly physical experimentation.

Milestones & Achievements

The key achievements are summarized in the following table.

Project	Key Achievements
University of Alberta Combustion Chair	<ul style="list-style-type: none"> ▪ Developed capability for pre-combustion removal of mercury from sub-bituminous coals ▪ Identified heating conditions favoring effective removal of mercury from a variety of Alberta coals
CCPC Phase 1 & 2	<ul style="list-style-type: none"> ▪ Gasification offers the best commercial potential for converting low value fuels into high value products ▪ Insufficient experience with low-rank Alberta coals ▪ Promising opportunities in Alberta for polygeneration, including the capture and use of CO₂ for enhanced oil recovery and enhanced coalbed methane
Coal Cleaning	<ul style="list-style-type: none"> ▪ New beneficiation processes appear to be technical and economically feasible ▪ Beneficiated coal and coal/coke blends could dramatically reduce the cost of gasifiers and improve reliability

Project	Key Achievements
Gasification Testing of Alberta Feedstocks	<ul style="list-style-type: none"> Established a sample bank of representative feedstocks Selected process developers and R&D labs capable of evaluating coal samples.
Biomass Gasification	<ul style="list-style-type: none"> Gasification of pelletized municipal solid waste is technically feasible Using the results from the Phase One study, a pre-commercial gasification plant is being designed
Novel Gasification Technology	<ul style="list-style-type: none"> Novel molten iron gasifier technology was evaluated, and mature challenges to bring this technology to market identified.

Future Developments

- Technologies will be developed for the pre-combustion removal of mercury from sub-bituminous coals.
- The best coal cleaning and beneficiation technologies will be identified by June 2005.
- A coal gasification characteristics sample bank will be created by December 2005.
- The CCPC will select the best technology, feedstocks and location for an integrated polygeneration demonstration plant. The detailed engineering design and cost optimization of such a plan will be completed by December 2006.
- Novel gasification technologies, with breakthrough potential, will be identified and developed.

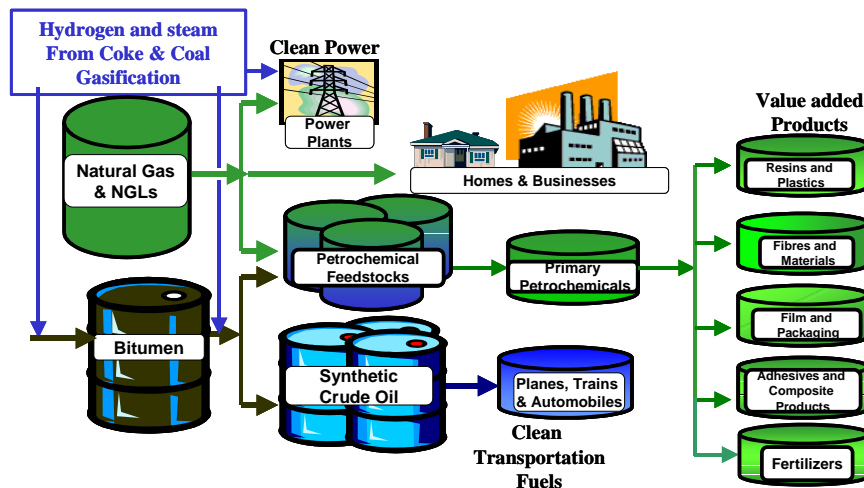

What the Future may look like - Integrated Energy Industry, Diversified Products, Broad Markets

IV. Upgrading Program

Bitumen from Alberta's oil sands is marketed today either unprocessed or upgraded (e.g. synthetic crude oil). Unprocessed bitumen is currently mixed with 20 to 30% of diluent, so it can be shipped to market through pipelines (DilBit). Diluent requirements are expected to triple over the next 10 years as the industry expands. Shortfalls in supply are already occurring, and some companies are using varying amounts of synthetic crude oil (SynBit and SynDilBit) as a diluent substitute.

Upgrading of heavy oil or bitumen is generally achieved through one of two mechanisms: carbon rejection or hydrogen addition. In Alberta, most of this upgrading has historically been achieved through the thermal carbon rejection process known as coking. Hydrogen addition technologies, while more costly than coking, offer higher yields of higher quality products.

Partial upgrading at remote field production sites would make the product easier to transport, thus reducing the need for mixing with diluents, while removing some of the impurities. Many enhanced oil recovery processes, such as VAPEX or in situ combustion, also offer the potential for partial upgrading.

Research, Technology, and Innovation

There are very few new upgrading technologies under development globally despite the increasing supplies of heavy oil and bitumen in world petroleum markets. For example, at a recent international conference in Antwerp, Belgium (October, 2004), held to showcase the latest in "bottom of the barrel" refining technologies, only incremental improvements for existing technologies were presented. The primary reason was that most companies are reluctant to invest in novel, unproven processes due to the very high cost of incorporating new technology into their upgraders and refineries, and the low rate of return on investment.

China has made significant strides in the development of novel heavy oil processing technologies, due to its high dependence on imported crude and its primarily diesel-based market demand. It has developed new catalysts to increase the yield of petrochemical feedstock in its refineries, in order to reduce its dependence on foreign imports.

Canadian research focuses primarily on developing incremental improvements for existing coking and hydro-treating processes. However, there are some interesting advances being made in the area of catalysis at universities in Quebec, Ontario and Alberta.

AERI has identified the following challenges:

- Increasing cost and decreasing availability of natural gas for heat and hydrogen production in upgrading
- High water dependence for hydrogen production
- High greenhouse gas emissions from upgrading processes
- Limited markets for synthetic crude oil and diluted bitumen
- Lack of refinery capacity in the U.S. suited to Alberta bitumen and bitumen-derived feedstocks
- High capital costs for upgraders
- Lack of availability of low-cost upgrading processes that can be used in the field to reduce diluent requirements.

Program Vision

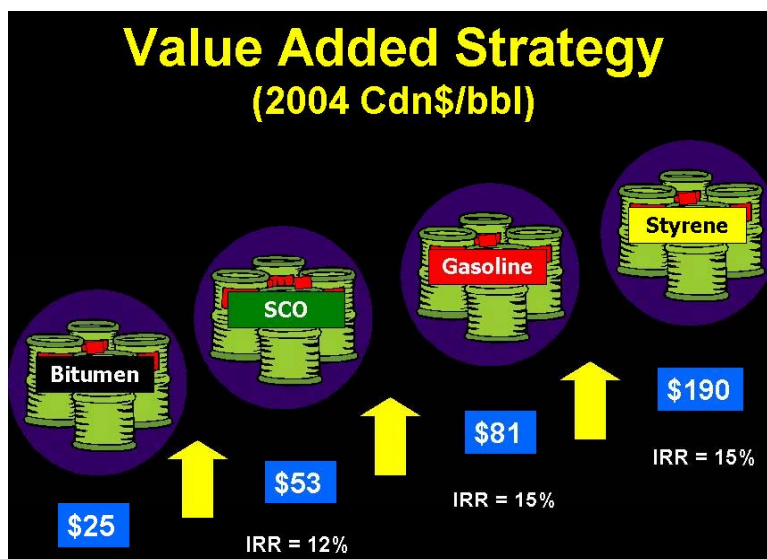

Figure – Potential Return on Investment through Upgrading

The highest potential payoff will come from integrating the various production, upgrading, refining, and other value added steps into a unified whole. The above figure shows the increased return on investment achievable by increasing the value of bitumen through upgrading.

Working with industry and other government agencies, AERI has formulated the following vision: *Alberta has achieved a competitive hydrocarbon industry that expands the market for Alberta's bitumen resource and produces higher value products in Alberta.*

2004-05 Activities

In 2004, the AERI upgrading program changed its focus from primarily supporting incremental technology improvements to proactively seeking projects

demonstrating a combination of new technologies and the integration of some key links in value addition.

It now targets four core technology platforms:

- Separation technologies
- Catalysis (primarily ring-opening catalysts)
- Utilization of bitumen fractions
- Process integration (need to be consistent with punctuation in bulleted lists)

These technology platforms are intended to achieve the following goals:

- **Product Diversification** to add value to bitumen in Alberta, and expand access to new markets. This will require an investment to advance “ring-opening” catalytic cracking technology to both improve synthetic crude oil quality (and therefore its market acceptance), and produce refined products and petrochemical feedstocks.
- **Full Resource Utilization** by using separation technologies as a pretreatment to make bitumen products, such as a generic benchmark feedstock that could be used in any refinery in the world, or feedstocks for manufacturing high-value products, to remove impurities that lower bitumen quality, and to reduce water usage. The heavier ends removed by separation can be used in other processes, such as gasifier feed or the manufacturing of new carbon- or sulphur-based materials.
- **Reducing Reliance on Natural Gas** by adapting gasification technology to convert the least valuable residue from the bitumen barrel into the fuel, power and hydrogen required in the upgrading process, or by diverting them to an alternate use, including the development of new carbon-based products.
- **Field Upgrading** at remote production sites would make the product easier to transport, thus reducing the need for mixing with diluent or synthetic crude, while removing some of the impurities. Many enhanced oil recovery processes also offer the potential for partial upgrading.
- **Reducing Greenhouse Gases** is critical to the sustainability of the oil sands industry. Greenhouse gas reduction could be achieved by integrating processes to increase efficiency, and the development of new lower energy-intensity processes to add value to the resource.

Milestones & Achievements

The key achievements and findings from AERI-funded projects are summarized in the following table.

Project	Key Outcomes and Analysis
University of Alberta Upgrading Chair	<ul style="list-style-type: none"> ▪ The first term of Chair was completed in February 2005. Research primarily focused on coking (no longer an AERI Upgrading priority), with some investigation of bio-upgrading.

Project	Key Outcomes and Analysis
AERI/NOVA Project to Develop Petrochemical Feedstocks from Heavy Gas Oils	<ul style="list-style-type: none"> ▪ Development of a new family of catalysts that has the potential to provide a step-change in the processing of Alberta bitumen towards higher-value products. These catalysts were developed at the State Key Laboratory of Heavy Oil Processing in Beijing, China. ▪ Significant progress has been made towards developing the ring-cleavage catalyst required to make the ARORINCLE process (the other half of the two-stage process under development) a success. This work is being carried out at the University of Stuttgart, Germany. ▪ Patent applications are being prepared for the catalysts from both parts of the project. ▪ The German catalyst work should also have a high potential for use in processing the syngas resulting from the gasification of Alberta bitumen coke. The successful progress of this project to date has shown that the technology to make petrochemical feedstocks from heavy bitumen fractions is achievable.
Hydrocarbon Upgrading Task Force (HUTF) Workshops on Adding Value to Alberta's Oil Sands	<ul style="list-style-type: none"> ▪ AERI and EnergyINet, Alberta Department of Energy (ADOE), Alberta Economic Development (AED), the Alberta Chamber of Resources, as well as several professional societies, co-organized a series of workshops in February, 2005 to determine what needs to be done on the non-technology side to ensure that the vision of an integrated polygeneration complex in Alberta by 2020 becomes a reality. ▪ The workshops were extremely well attended, drawing 156 registrants to both the Calgary and Edmonton sessions. Senior officials were drawn from all aspects of the industry (bitumen production, upgrading, refining, petrochemicals, and pipelines), as well as from academia, research and government. Prominent supporters from government included the Honorable Greg Melchin, Alberta Minister of Energy, and the Honorable Clint Dunford, Alberta Minister of Economic Development, and industry notables were Neil Camarta, Senior VP, Shell Canada, Jim Dinning, former VP, TransAlta, and Paul Clark, VP, NOVA Chemicals. ▪ The outcome of the workshops was a series of specific recommendations for industry and government to pursue to make the vision a reality. These recommendations are now being acted on by ADOE and AED, to ensure that business conditions are favorable by the time that AERI and NOVA have commercially demonstrated the process. ▪ AERI is a founding member of the Hydrocarbon Upgrading Task Force, a joint industry-government group that is promoting the value-added vision for Alberta bitumen. AERI will continue to play a chief role in the HUTF, as the Vision 2020 is not achievable unless the upgrading technology is developed.

Project	Key Outcomes and Analysis
Catalysis	<ul style="list-style-type: none"> ▪ AERI has funded four projects on the development of novel catalysts, including a cooperative program between the University of Calgary and the University of Stuttgart to validate the ring cleavage catalysts being developed at the latter. ▪ AERI also is monitoring the catalysts being developed at Concordia University, for their potential application with Alberta oil sands –derived bitumen.

Future Developments

Key issues arising from the HUTF workshops were the difficulty in demonstrating new technology and the lack of trained personnel in this area. AERI established a steering group and technical advisory committee to investigate the feasibility of building a Hydrocarbon Upgrading Demonstration and Test Facility in the province, to allow for large-scale demonstration of new technologies, while providing a training facility that could be shared with industry and academia, and providing students with practical, hands-on experience. It is strongly recommended that this project be fast-tracked, as it could provide a means to demonstrate new technologies arising from the AERI upgrading program.

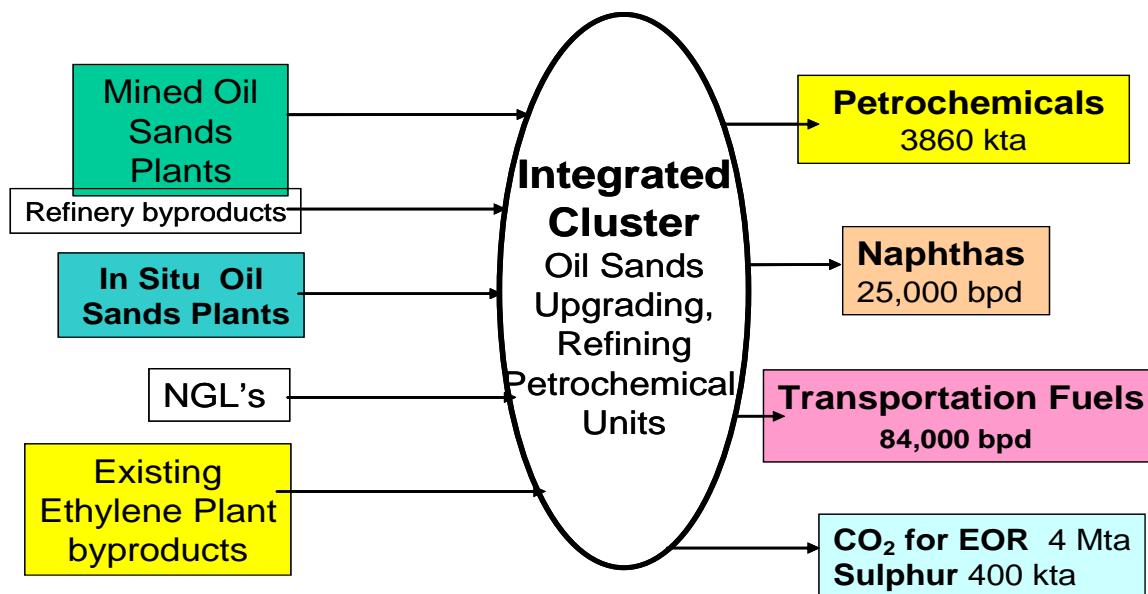

V. Improved Recovery Program

Conventional light oil production in the Western Canadian Sedimentary Basin peaked in 1973 and by 2001 had declined by approximately 60%. The shortfall has been filled by increased production of conventional heavy oil using new extraction techniques (16% of total oil production in 2001, up from 4% in 1973) and the extraction of bitumen from the oil sands (43% of total production in 2001, up from 4% in 1973). Current trends also show that conventional natural gas production has peaked and will start to decline.

In 2003, AERI commissioned the “Spudding Innovation” report. The study highlighted concern of the dwindling investment in oil and gas recovery research in the face of aging reservoirs and shrinking reserves, specifically within the Western Canadian Sedimentary Basin (WCSB) and it estimated:

- Only 27% of conventional oil from known sources is being recovered in the WCSB. The remaining 73% will remain in the ground, as current technology is not available to extract the balance due to technological, environmental, social and economic barriers. With the next generation of technology that is already proven in the U.S., it is anticipated this recovery factor could be increased to an average of 41%. The economic impact of even 1% increase in recovery factor from the entire WCSB is estimated at \$4 billion in royalties and \$60 billion in national GDP.
- The recovery rate for conventional natural gas could be raised from 59% to an average of 72%.

Research, Technology & Innovation

There are some significant barriers to overcome before our resources can be sustained at significantly increased levels of production and greater overall recovery rates can be achieved. Though we've seen some amazing technological advances over the past years, we are reaching the limits of what current technology can do. We rely heavily on natural gas to create steam to produce bitumen, as well as to produce the hydrogen needed to upgrade the bitumen into something of greater value. As natural gas resources decline and become more expensive, today's practices will not be sustainable.

Current recovery processes also use a great deal of water and there's growing concern about water supply and quality. Emissions of greenhouse gases from recovery processes, particularly carbon dioxide (CO₂), are high and are expected to increase with maturing reservoirs.

Program Vision

AERI, through the Energy Innovation Network (EnergyINet), has developed a program in the area of recovery. The focus is on the development and

demonstration of technologies to enhance conventional oil and gas, unconventional gas, and in situ bitumen production.

Recovery program goals include:

- Successfully recovering more hydrocarbons from matured or technically difficult reservoirs, which have the potential of adding hundreds of billions of dollars to the economy of Canada.
- Capturing, pipelining and sequestering the greenhouse gas CO₂ produced from energy production and injecting same into geological storage opportunities including hydrocarbon reservoirs which are anticipated to increase the ultimate recovery.
- The successful development, adaptation, and implementation of new technologies, procedures, and methods designed to greatly reduce the energy consumed to produce our energy resources.
- More efficient use of fresh water resources within the realm of secondary recovery of hydrocarbons and bitumen.

2004-05 Activities

The Natural Gas and Conventional Oil Recovery EnergyINet Industry Advisory Committee was created and four field demonstration projects approved under the CO₂ Royalty Credit Program were initiated. The Gas Over Bitumen Technical Solution committees were strengthened and AERI worked with ADOE to develop evaluation processes for the Innovative Energy Technologies Program. There was increased industry support of the AERI/ARC/CORE/Industry (AACI) Program. In addition, AERI supported various strategic field pilots and demonstration projects.

AERI collaborated with Natural Resources Canada in a detailed technology roadmap titled, "Bitumen Recovery Technology: A review of Long-term R&D Opportunities". This followed similar work that focused on heavy oil and bitumen upgrading completed in March 2004. The study identified gaps that are pertinent to future sustainability, energy reductions, emission offsets, and water usage.

AERI continued to participate in the AACI program that provides fundamental research, process development and technology transfer for oil sands and heavy oil processes, including thermal, solvent, thermal and solvent hybrid, and heavy oil techniques, and participates in strategic field demonstration projects.

For Gas-Over-Bitumen, the Gas/Bitumen Executive Committee currently working on this aspect of the Bitumen Recovery program was strongly supported by AERI and ADOE. Several research and demonstration projects are currently underway in search of a technical solution for concurrent gas and bitumen production in pressure depleted gas overlain bitumen reservoirs.

Milestones and Achievements

The key milestones and achievements from AERI-funded projects are summarized in the following table.

Project	Key Outcomes and Analysis
Gas-Over-Bitumen	<ul style="list-style-type: none"> ▪ Investigation of hybrid SAGD, low-pressure SAGD, high-pressure/high temperature artificial lift systems design and testing, wellbore architecture modifications, reservoir pressure maintenance, synergies with solvent work, field demonstration pilots.
In Situ Solvent Recovery	<ul style="list-style-type: none"> ▪ Determined the capacity and production rates of various solvent injection/recovery techniques for in situ bitumen and conventional heavy oil. ▪ Single solvents, various blends, steam solvent, and heated solvents were tested in the lab and the field in order to reduce energy intensity, water usage, and greenhouse gas emissions as compared to SAGD.
Gas and Conventional Oil	<ul style="list-style-type: none"> ▪ A study investigated and identified reservoirs and innovative technology and techniques capable of adding significant recoverable reserves.
Combustion	<ul style="list-style-type: none"> ▪ In situ combustion techniques developed for bitumen and heavy oil, including post primary production. Such technologies have the potential to replace natural gas for steam, reduced water consumption, and reduced emissions and to prolong life of conventional heavy oil reservoirs.
Coal bed Methane	<ul style="list-style-type: none"> ▪ CO₂ and acid gas production enhancement, fracture technology, water handling, water quality and gas component tests and studies.
CO₂ EOR	<ul style="list-style-type: none"> ▪ Gas capture and separation technologies and economics. Identification of candidate locations and available point sources and infrastructure.
Materials	<ul style="list-style-type: none"> ▪ Economical and robust materials to withstand high temperatures, high-pressure operations, and corrosion for well completions and production processing and transportation.
Enhanced Gas Recovery	<ul style="list-style-type: none"> ▪ Flue gas and CO₂ capture and injection, lab and simulation verification, and simulation technology development.
Drilling Technology	<ul style="list-style-type: none"> ▪ Support of Drilling Chair at University of Calgary.
Thermodynamics	<ul style="list-style-type: none"> ▪ Support of Thermodynamics Chair at University of Alberta.
Separation technology	<ul style="list-style-type: none"> ▪ Technology to remove sulphur, nitrogen, oxygen, and particulates from gas plants and other industrial sources to improve CO₂ economics.
Simulation modeling	<ul style="list-style-type: none"> ▪ Development of more sophisticated computerized modeling of how the many highly complicated chemical processes involved work together, making it possible to predict enhanced oil, gas, and coal bed methane recovery processes, and thus optimizing these processes by reducing costly physical experimentation.
Tailings Research	<ul style="list-style-type: none"> ▪ Technology development to reduce water content, emissions and to increase remediation stability of oil sands mining

Project	Key Outcomes and Analysis
	processing waste products.
Innovative Energy Technologies Program	<ul style="list-style-type: none"> • Evaluation of proposals, recommendations for funding, technical management, and compliance monitoring of successful projects.

Future Developments

Challenges

- Promoting integrated and collaborative approaches in a highly fragmented industry consisting of a large diversified group of stakeholders that includes production income trusts, small and large energy companies, service companies, research providers, universities, and various governments.
- Completion of an industry-led, next generation technology roadmap for both Conventional Oil and Gas and Unconventional Natural Gas and In-Situ Bitumen.
- Support of Gas-Over-Bitumen technical solutions industry group’s initiatives and the formalization of collaboration.
- Instituting market incentives to encourage uptake and deployment of technologies including:
 - The announcement by the Alberta government of a \$15 million royalty program to support four CO₂ enhanced oil recovery demonstration projects and the announcement by the federal government of a similar \$15 million program.
 - Implementation of the Alberta government \$200 million Innovative Energy Technologies Program.
- Intellectual property issues remain a barrier for collaboration in testing of advanced technologies.

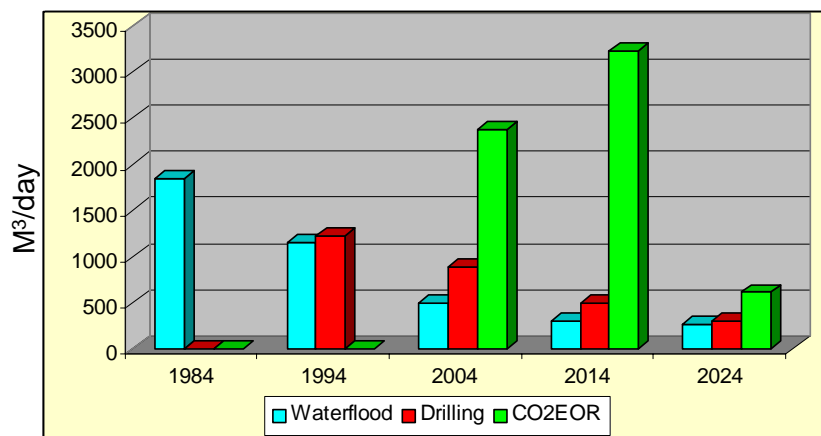

Actual and projected production in the Weyburn Field showing the marked impact of CO₂ enhanced oil recovery

VI. Alternate & Renewable Energy Program

- Alberta has significant bioenergy and other renewable energy resources that have yet to be commercially exploited.
- Alberta produces and uses more hydrogen than any other province in Canada, and is one of the world's centres of hydrogen production, making it the most likely jurisdiction in Canada to be part of the "Hydrogen Economy".
- Fuel cells are the most efficient electricity producing machines known. They can be up to three times more efficient than typical automotive internal combustion engines, resulting in the corresponding decrease of carbon dioxide emissions. Fuel cells are expected to operate as distributed energy sources, reducing the need to increase the capacity of the existing electrical grid. Fuel cells can produce very pure carbon dioxide, suitable for other purposes such as enhanced oil recovery. In addition, fuel cells can use harmful waste product such as H₂S to produce hydrogen and electricity.

Research, Technology and Innovation

- It is expected that a significant portion of our renewable energy commitment would also come from bioenergy and other renewable energy sources.
- Alberta has adopted a fuel cell development and deployment strategy that can accommodate impure hydrogen as a feedstock as part of the plan to allow Alberta's industry to produce 2.5% of Alberta's energy demand by 2012 and 5% by 2020.
- The rationale for this strategy is that impure hydrogen will be (or already is) widely available long before pure hydrogen is available, and that using impure hydrogen provides many of the Kyoto benefits without requiring expensive fuel clean up or new infrastructure for distribution and storage of hydrogen.
- The only types of fuel cell that can readily use impure hydrogen are high temperature fuel cells, of which there are two main types (molten carbonate and solid oxide). While molten carbonate fuel cell technology is mature, it is viewed that solid oxide is likely to be the dominant technology within five to ten years, perhaps even more dominant than the Proton Exchange Membrane (PEM) technology developed by companies like Ballard. In addition, Alberta already has a significant expertise in solid oxide fuel cells, with about 20 research groups among the Universities of Alberta and Calgary, and two companies active as well (Versa-Power, formerly Global Thermoelectric, an acknowledged world leader, and the Alberta Research Council (ARC), which has a very innovative technology).
- Solid oxide fuel cells, or SOFCs, are a class of fuel cells that are based on ceramic composites. SOFCs are not a mature technology, although they were invented 70 years ago. While there are companies that produce small quantities of SOFC core components such as Siemens Westinghouse and TOTO, all other companies produce lab prototypes. No one technology or

design dominates the industry. Consequently, there is intense competition to develop a commercially viable product worldwide, primarily for units producing 5 kW to multi-megawatts.

Program Vision

- The aim of this program is to develop, improve and adapt alternate and renewable energy technologies, such as hydrogen, fuel cells, geothermal and bioenergy.

2004-2005 Activities

- **Bioenergy Research & Innovation Strategy Development:** AERI staff participated in several workshops, led by the Alberta Agricultural Research Institute and involving representatives from industry, academia, the federal government and several provincial government departments to develop a bioenergy research and innovation strategy.
- **Geothermal Energy for Alberta's Oil Sands:** AERI, working with oil sands producers, is examining the feasibility of setting up a geothermal energy demonstration project, which would provide process heat for the Steam-Assisted Gravity Drainage projects in Northern Alberta.
- **Western Canada Fuel Cell Initiative:** In recognition of Alberta's strong position in Canada relative to SOFCs, AERI undertook to develop a programmatic approach to SOFC research for impure hydrogen. Consequently, the existing University Research Program projects, as applied to fuel cells, were integrated on a going-forward basis into this program. Working with the Universities of Alberta and Calgary, and the Alberta Research Council, AERI provided funding for the Western Canada Fuel Cell Initiative program. This program includes 14 research groups and ARC. The key themes of investigation are:
 - o Novel electrode/electrolyte deposition and fabrication methods
 - o Overcoming sulfur-related performance degradation
 - o Overcoming hydrocarbon-based performance degradation (coke formation)
 - o Development of high temperature proton conducting electrolytes
 - o Engineering modeling of fuel cell systems.

This is a significant achievement, since both of Alberta's major universities and the Alberta Research Council have entered into a completely integrated research program. Members of the themes are drawn by discipline, skill and interest to form a working team. All themes have members from more than one institution. This degree of collaboration will significantly enhance the probability of success.

- **University Research projects:** Overall, the projects performed well according to the schedules and the major milestones were generally

achieved. In particular, a project regarding development of a hydrogen sulphide fuel cell achieved its target performance.

- **NAIT Fuel Cell Demonstration:** This demonstration and educational project has been producing power since November 12, 2004, at full or nearly full power, achieving gross efficiencies in excess of 70%. This is double the efficiency of a conventional power. A 5 kW SOFC fuel cell has been purchased and is scheduled for delivery in July 2005.

Future Developments

AERI will continue to assist in the development of a bioenergy research and innovation strategy for Alberta and a geothermal demonstration plant in northern Alberta and continue to fund hydrogen and fuel cell related projects.



NAIT Fuel Cell Interpretative Centre

VII. Carbon Dioxide Management Program

The challenge of climate change requires us to reduce the amount of anthropogenic greenhouse gases (GHG) that are emitted into the atmosphere. No single GHG mitigation strategy will provide a solution to this problem. However, CO₂ capture and geological storage is a particularly attractive technology to reduce Canada's GHG emissions. This technology involves capturing CO₂ from large point sources and storing it underground in geological formations. In addition, CO₂ can be used to enhance the recovery of oil and coal bed-methane. It is an attractive option because it allows continued use of fossil fuel resources and provides the time required for the transition to lower-carbon intensive technologies.

Canada has important options for geological storage in the depleted or underutilized pore space of the mature Western Canadian Sedimentary Basin (located in northeastern BC, Alberta, southern Saskatchewan and southwestern Manitoba). Canada also has the world-class expertise in carbon capture and storage. Alberta is unique, in the sense that it not only requires geological storage to reduce CO₂ emissions, but it requires hydrogen to process its large bitumen resource (a situation which could lead to Canada being a world leader in the transition to zero emission fuels because of the potential synergies between CO₂ storage and hydrogen production).

Research, Technology & Innovation

- CO₂ Capture and Storage research and innovation is being conducted in several places, including the International Energy Agency's Greenhouse Gas R&D Program and in Australia and the United States. Key challenges include reducing the CO₂ capture and transportation costs and developing cost-effective mechanisms for deep geologic storage.
- In Canada, the Canadian CO₂ Capture & Storage Technology Network has been established. There are several CO₂ Capture and Storage research and development initiatives, including the following:
 - The AERI-supported Acid Gas Re-injection project is completing a hydro-geological characterization of several operations selected from 43 acid-gas sites in Alberta and B.C.
 - The Canadian Clean Power Coalition (CCPC) initiative, which has already been described in an earlier chapter.
 - The CANMET CO₂ Consortium, which is intended to develop oxy-fuel combustion technology for CO₂ capture and storage.
 - CO₂ Sequestration in British Columbia, which is a review of potential CO₂ sinks and of major point sources.
- Phase 1 of the monitoring project in Weyburn was successfully completed and showed that the risk of CO₂ leakage over a period of thousands of years

is small. AERI participated in Phase 1 and is participating in Phase 2 of Weyburn, which is just underway.

- Four CO₂ enhanced oil recovery projects (EOR) were initiated in 2004 under the ADOE's CO₂ Royalty Credit program. Because of this and other AERI-supported projects, Alberta is a leading player in CO₂ Capture and Storage research and development.

Program Vision

The aim of this program is to reduce greenhouse gases by developing technologies to capture, transport and store carbon dioxide – and use it to increase oil and gas recovery. The intent is to make a concerted and coordinated effort to push suites of CO₂ capture and transport and storage technologies and strategies needed for evolving fossil energy systems and infrastructure over the top from “developing” through “commercially available” to “commercially attractive” in Canada within the next 10 to 20 years.

2004-05 Activities

- **Canadian Projects:** AERI continued to support Canadian projects such as the CANMET CO₂ Consortium, the North American CO₂ Test Centre in Regina and the PTRC Weyburn CO₂ Monitoring project in Saskatchewan.
- **CMG Reservoir Model:** The Computer Modelling Group's (CMG) reservoir model was modified in order to simulate CO₂ storage.
- **Penn West Field Pilot:** A CO₂ monitoring program was developed for one of the four CO₂ EOR projects that were initiated in 2004 by Penn West. Several projects were initiated and/or completed within this program.
- **University Projects:** AERI supported several university research projects at the University of Alberta and University of Calgary to conduct CO₂ Capture and Storage research on a sustained basis.

Milestones & Achievements

The key milestones and achievements from AERI-funded projects are summarized in the following table.

Project	Key Outcomes and Analysis
Weyburn CO₂ Monitoring	<ul style="list-style-type: none"> ▪ Phase I of this project was completed. It showed that CO₂ could be successfully stored within oil reservoirs
Computer Modelling Group Reservoir Model	<ul style="list-style-type: none"> ▪ The CMG reservoir model was successfully modified for the simulation of CO₂ storage
PennWest Field Pilot	<ul style="list-style-type: none"> ▪ Coring and Instrumentation projects were successfully completed and a baseline seismic survey was initiated.

Future developments

Major research programs in field monitoring, measurement and verification will be accelerated at the Alberta Geological Survey, the University of Alberta, the University of Calgary and the Alberta Research Council. A comprehensive program on risk analysis modelling will be initiated.

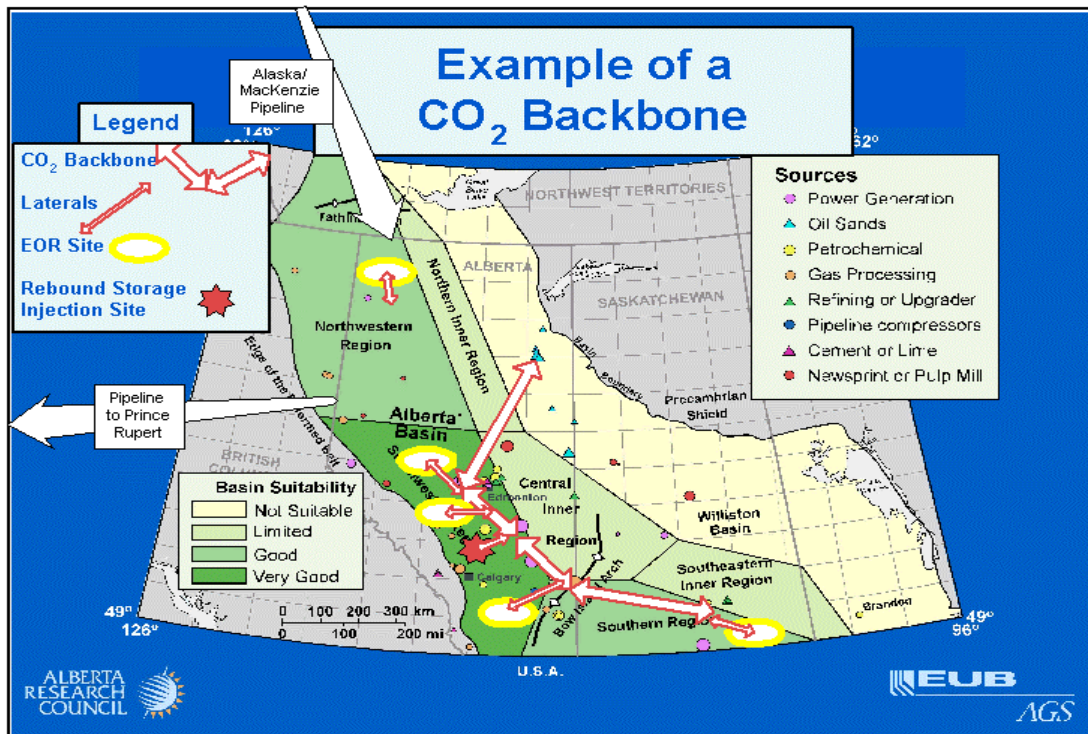

First stage of a backbone linking hubs in the Western Canadian Sedimentary Basin

VIII. Water Management Program

Water and energy are closely linked. Water is co-produced with oil and gas. It is needed to produce heavy oil, hydrogen and to cool power reactors. Energy is required for water treatment and desalination.

With around 0.5 percent of the global population, Canada has 20 percent of the world's freshwater supplies. Surface water is well delineated but groundwater is not. Canadians have the cheapest drinking water prices and are among the highest per capita consumers in the world. Regional water shortages have been caused by drought and generally been of short duration. Other issues that concern us include the safety of drinking water supplies, the availability of water for recreational, livestock and agricultural purposes and the protection of our ecosystems.

For 2001, the oil and gas sector was licensed to use 4.6 per cent of all the water allocated in Alberta (less than two per cent of the all the water allocated in Alberta is licensed to water and steam injection operations). By comparison, the agriculture sector (including irrigation) was licensed to use the largest amount of water of any economic sector, at approximately 45 per cent. Municipal water supplies accounted for 11 per cent.

Of the total water allocated in the province, the oil and gas sector uses less than 0.5% for water and steam injection processes (enhanced oil recovery). Water diverted for these purposes has declined from 88.7 million cubic meters in 1972 to 47.5 million cubic meters in 2001.

Research, Technology & Innovation

- There is plenty of water in the world; but 99.7 percent is not fit for human or animal consumption. Currently, global water withdrawal is estimated to be around 30 percent of the world's total accessible fresh water supply. By 2025, that fraction may reach 70 percent¹. New energy-efficient water treatment, recycling and desalination technologies would be required, in order to address potential water shortages.
- In the United States, power plant cooling and agricultural irrigation each account for 39 percent of freshwater use. Water shortages have occurred in some parts of the United States, which is increasingly vulnerable to such shortages. Competition for fresh water has limited electric power production in Georgia, Idaho, Massachusetts and North Carolina.

¹ Hoffman, Alan, "The Connection: Water and Energy Security", Institute for the Analysis of Global Security, August 2004

- In Alberta, fresh water is available mainly in northern regions (87% of Alberta's waters flow north) whereas the population and industrial activity is mainly in the central and southern regions².

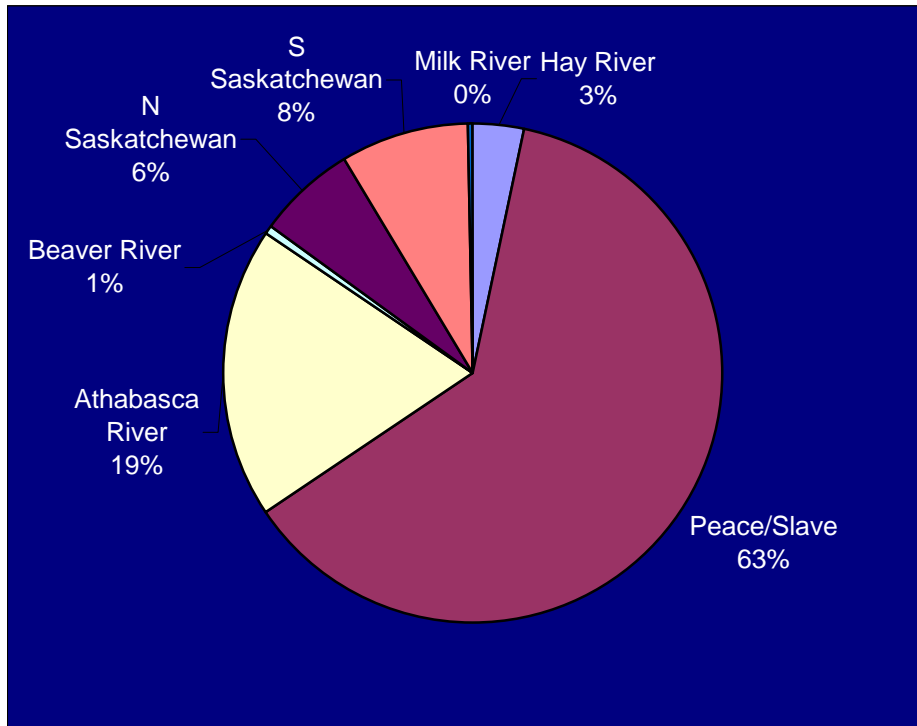

The estimated annual water demand by the energy industry is shown in the figure below.

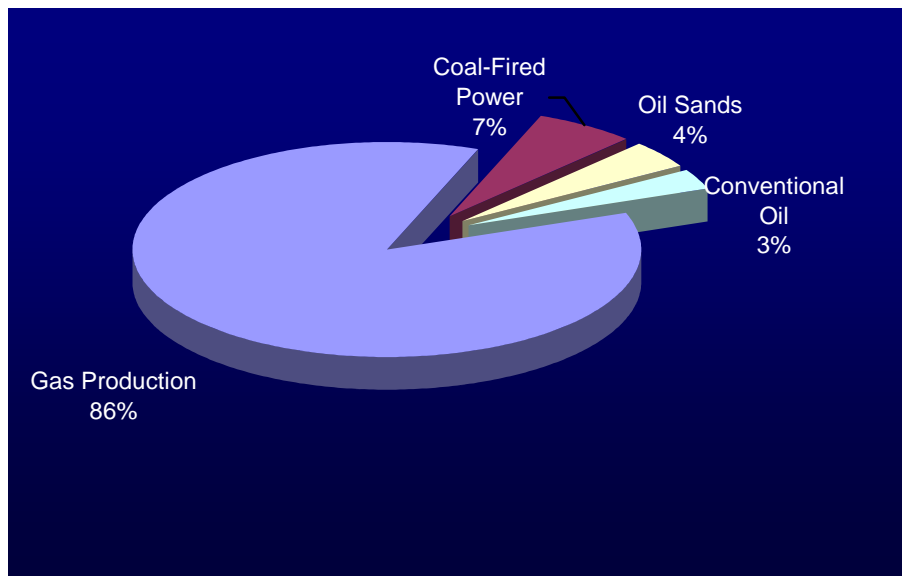

² Peachey, Bruce, "Strategic Needs for Energy Related Water Use Technologies", AERI Report, February 2005

It is estimated³ that the water use by the oilsands mining industry would double by 2020. However, without a significant reduction in fresh water use the limit in bitumen production that withdrawals from the Athabasca River will support is estimated at 3 million bbls/day. Two ways of significantly reducing fresh water withdrawals are to reduce tailings pore water losses and reduce the process water inventory.

Program Vision

The aim of the program is to recognize the dependence of the energy industry on water, by developing technologies that would reduce the use of fresh water and implement cost-effective water re-use and recycle systems. A formal vision has yet to be developed for this program.

2004-05 Activities

Water Management is a crosscutting initiative; AERI-funded projects in other strategic focus areas have reduced water consumption as one of their primary objectives. For example, in the Recovery area, the DOVER Vapex field project would result in lower freshwater consumption and carbon dioxide enhanced oil and gas recovery would reduce the water flooding requirements.

Milestones & Achievements

In addition to the projects listed in earlier sections, the key achievements and findings from AERI-funded projects are summarized in the following table.

Project	Key Outcomes and Analysis
Energy Industry Water Needs Analysis	<ul style="list-style-type: none"> ▪ A study was completed on the energy industry's water use. It identified what needs to be done in order to reduce freshwater useage.
Coalbed Methane Production	<ul style="list-style-type: none"> ▪ A water-sampling project was initiated in order to understand the characteristics of water that would be co-produced with methane.

Future Developments

- The EnergyINet water management program will be launched.
- More water management projects will be solicited.

³ Sawatsky, Les, "Water Use by the Oil & Gas Industry: Confronting Water Scarcity", APEGGA Annual Conference, Calgary, April 2005

IX: Financial Details

Program	2004-05 Expenditures ('000's)
Clean Carbon/Coal	\$2,440
Oil Sands Upgrading	\$1,764
Improved Recovery	\$3,207
Alternate and Renewable Energy	\$1,403
CO ₂ Management	\$4,463
Water Management	\$133
Technology Management ⁴	\$1,225
Grand Total	\$14,635

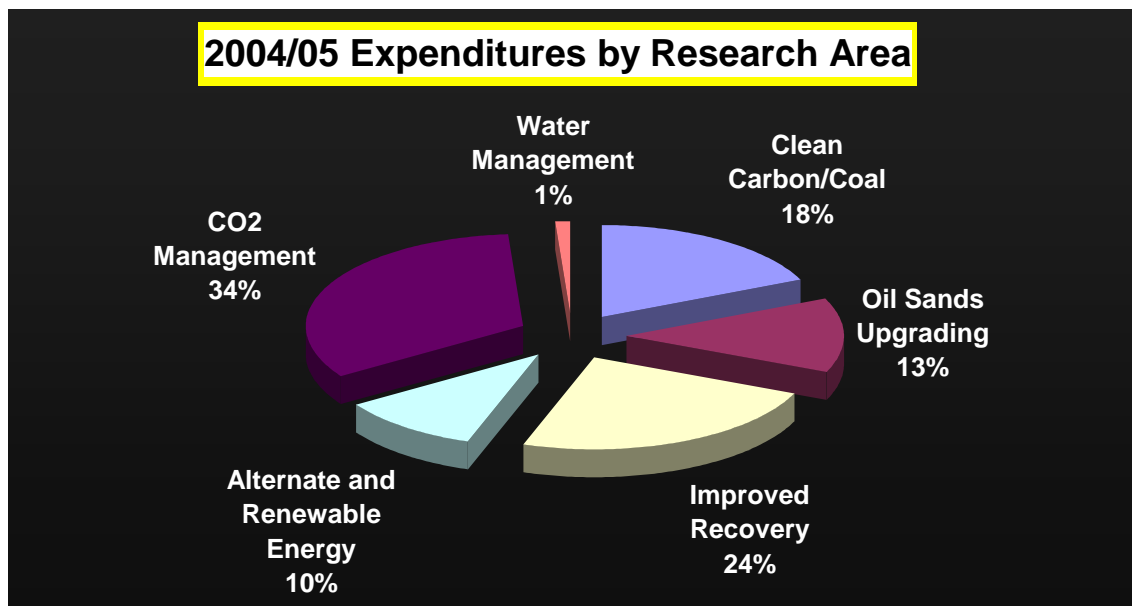

⁴ Includes in large part the start-up and operations of EnergyINet