

# Evaluation Report 124



Gilmore Tatge 706W Dump Chief High Dump Wagon

A Co-operative Program Between



## GILMORE TATGE 706W DUMP CHIEF

### MANUFACTURER:

Gilmore Tatge Manufacturing Co., Inc.  
Clay Center  
Kansas, U.S.A.  
67432

### RETAIL PRICE:

\$8,290.00 (December, 1979, f.o.b. Winnipeg, Manitoba, with optional forage roof kit and telescoping tongue hitch).

### DISTRIBUTOR:

Robinson-Alamo Sales Limited  
1380 Waverley Street  
Winnipeg, Manitoba  
R3T 0P5



FIGURE 1. 706W Dump Chief: (A) Telescoping Tongue, (B) Mechanical Bolster Stabilizers, (C) Swing-Away Roof, (D) Extending Columns.

### SUMMARY AND CONCLUSIONS

Overall functional performance of the Gilmore Tatge 706W Dump Chief was very good in forage and root crops. Ease of loading and unloading was excellent.

The two stage unloading cycle was effective in providing both low loading height and high unloading clearance. The front opening was compatible with most forage harvesters. The optional forage roof provided good protection from wind loss when harvesting in moderate winds. Without the forage roof, box height was low enough for easy side loading from sugar beet harvesters.

The 3.1 m (10 ft) unloading height was adequate to clear most truck boxes equipped with side forage box extensions. Due to the sideways movement of the dump box during unloading, the forage was placed near the centre of large truck boxes resulting in negligible losses. Unloading time was dependent on the hydraulic system of the tractor used, but was usually less than one minute.

The Dump Chief was stable during dumping on level ground.

Two access doors in the bottom of the box were provided for cleaning, however, access to the inside of the box was inconvenient.

The unloaded Dump Chief towed well, on smooth roads, at speeds up to 40 km/h (25 mph). The tire load ratings were ex-

ceeded by 40% when the wagon was loaded to its 8.2 t (18,000 lb) rated capacity.

Care had to be taken to avoid unloading under power lines. The 6.2 m (20 ft) maximum height during unloading exceeded minimum power line heights in the prairie provinces.

Several mechanical problems occurred with the hydraulic dump systems and bolster locking mechanism, during the test.

### RECOMMENDATIONS:

It is recommended that the manufacturer consider:

1. Modifying the front bolster stabilizer to eliminate bending of the control bars.
2. Modifying the hydraulic system to eliminate cylinder synchronization problems.
3. Supplying tires rated for the specified wagon load.
4. Providing convenient access to the interior of the box.

Chief Engineer -- E. O. Nyborg

Senior Engineer -- J.C. Thauberger

Project Engineer -- R.R. Hochstein

## THE MANUFACTURER STATES THAT

With regard to recommendation number:

1. This has not proved to be a major problem for us, but we are currently testing components to eliminate this situation.
2. The hydraulic cylinders have been completely redesigned since the test wagon was manufactured. These changes include an increased bearing surface, clevis ends on the cylinders do away with side loading, and the placement of the larger cylinder on the rear to allow the most loading on this cylinder as well as an improved bypass valve within the cylinders.
3. 1980 units are being supplied with proper tire size recommendations for loads encountered.
4. The manufacturer feels that under normal conditions, cleaning and inspection can be carried out from outside the box.

**Note:** This report has been prepared using SI units of measurement. A conversion table is given in APPENDIX II1.

## GENERAL DESCRIPTION

The Gilmore Tatge 706W Dump Chief is an extending pivot, 14 cubic metre capacity, side dump wagon suited for handling chopped forage, special crops (such as sugar beets) and other bulk commodities. It is designed for towing behind a forage harvester or, with the roof removed, may be used for side loading from a sugar beet harvester or similar equipment.

Unloading is controlled with two hydraulic cylinders, connected in series and powered from a tractor hydraulic system. The Dump Chief has a two stage unloading cycle. The box initially raises while moving sideways, on inclined slides, before pivoting to dump. The optional expanded metal roof opens automatically during pivoting. The Dump Chief was factory assembled for dumping to the left, however, the dump direction may be reversed.

Detailed specifications are given in APPENDIX I, while FIGURE 1 shows the wagon unloading.

## SCOPE OF TEST

The 706W Dump Chief was towed behind a John Deere 3800 forage harvester in a variety of conditions, ranging from smooth hay fields to hilled corn fields, for 230 hours while dumping about 600 loads of chopped forage. In addition, it was operated alongside a sugar beet harvester for 10 hours and was towed both loaded and empty over primary and secondary roads for about 500 km. The Dump Chief was evaluated for ease of operation, load carrying capacity, operator safety and suitability of the operator's manual.

## RESULTS AND DISCUSSION

### EASE OF OPERATION

**Hitching:** The Dump Chief was equipped with a clevis hitch and a telescoping tongue. The tongue length could be varied by 610 mm (FIGURE 2) to suit various forage harvesters. It was compatible with most forage harvester blower spouts.

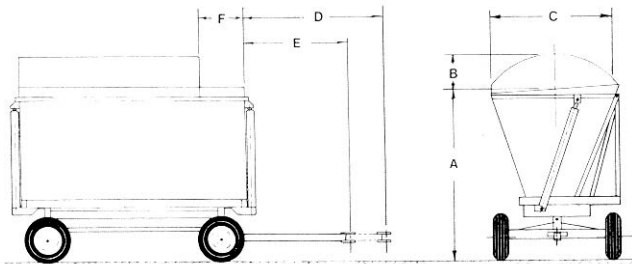

**FIGURE 2.** Dimensions for Harvester Compatibility: (A) Box Height, 3000 mm, (B) Roof Height, 700 mm, (C) Front Opening, 2700 mm, (D) Extended Tongue, 2300 mm, (E) Compressed Tongue, 1700 mm, (F) Roof Recess, 560 mm.

**Loading:** FIGURE 2 gives dimensions of the front forage opening, when equipped with the optional forage roof. The wide front

opening made slight field turns possible, without adjusting the forage harvester discharge spout. Opening height suited most forage harvester discharge spouts. The expanded metal roof provided good protection against forage losses in moderate winds. Some forage losses occurred in strong side winds due to the 560 mm roof recess, since the discharge spout had to be set up to clear the front of the box for unloading.

For side loading, the expanded metal roof had to be removed. Box height was low enough to easily fit under harvester unloading booms.

**Unloading:** The Dump Chief has a two stage unloading cycle (FIGURE 3) to provide both low loading height and high unloading clearance height. FIGURE 3 shows the unloading cycle and clearance dimensions when dumping.

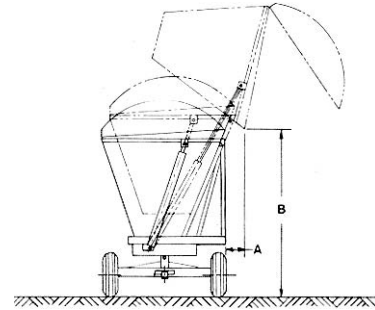

**FIGURE 3.** Unloading Clearance: (A) Horizontal, 480 mm; (B) Vertical (unloading height), 3100 mm.

During the first stage, mechanical stabilizers (FIGURE 1) automatically lock the front rocking bolster while the box moves 515 mm upward and 300 mm sideways on two telescoping inclined slides. The telescoping slides then lock in fully extended position and the box pivots to the side. A cable system automatically opens the roof during dumping.

Due to the sideways movement of the dump box during unloading, it was easy to fully fill a truck box, without appreciable loss on the receiving side. Forage was deposited close to the truck box centre line, resulting in uniform fill across the truck box width. The 3100 mm vertical dump clearance was adequate for loading with forage side extensions. Unloading time depended on the tractor hydraulic system, but usually was less than one minute. The 45° maximum dump angle was adequate, although when unloading high moisture chopped forage, small amounts were often retained, in the front and rear corners of the box, on the pivot side.

**Stability:** The manufacturer recommended dumping only on relatively level ground and only when parked next to a receiving unit, such as a truck box, to prevent possible upsetting. The Dump Chief was stable when dumping. Although the right tires were each filled with 90 kg of liquid ballast, the right rear wheel sometimes lifted slightly off the ground during dumping due to the mechanical stabilizer system. This gave the impression that the wagon was about to tip, however, no actual tipping occurred in which the wagon had to be supported by the truck box.

The maximum side slope on which the Dump Chief 706W could be safely unloaded depended on the flow characteristics of the material being handled. When unloading materials which bridge easily, such as high moisture chopped forage, the Dump Chief could tip sideways when unloading on side slopes or during high winds. With 90 kg of ballast in each of the two right wheels unloading should not be attempted on side slopes greater than 5 degrees<sup>1</sup>.

**Access and Cleaning:** Two 200 x 200 mm clean-out doors were provided in the bottom of the box. These could be conveniently opened from the ground and the openings were large enough for emergency clean-out in case of hoisting system malfunction. Access to the interior of the box, for cleaning or inspection, was inconvenient. It is recommended that the manufacturer provide convenient access for an operator to enter the box.

<sup>1</sup>PAMI T7827-R79, Detailed Test Procedures for High Dump Wagons

**Roof:** The optional pivoting roof performed well. It opened sufficiently during unloading and did not interfere with material flow. In addition, it provided good protection against wind when loading light material in moderate winds.

**Transporting:** The Dump Chief towed well on smooth roads at speeds up to 40 km/h. At higher speeds, the wagon began to sway excessively. Swaying was caused by free-play in the steering linkage. Total linkage free-play, measured at the end of the hitch tongue, with tongue length set at 2600 mm, was 160 mm.

**LOAD CARRYING CAPACITY**

**Manufacturer's Load Rating:** The manufacturer recommended that the maximum load should not exceed 8.2 t. Since the box had a capacity of 14 cubic meters, the box could only be partially filled with some materials such as some grains, before the recommended load rating was exceeded. With chopped forage, at 75% moisture content, on the other hand, the box could be completely filled without overloading. Comprehensive tables were provided in the operator's manual outlining the recommended filling levels for a wide variety of materials.

**Tires:** The Dump Chief was equipped with four, 12.5 x 15, 8-ply tires. When the wagon was loaded to the manufacturer's recommended 8.2 t maximum load, individual tire loads exceeded the maximum rating<sup>2</sup> by 40% for speeds up to 15 km/h. The Dump Chief was capable of carrying only a 4.0 t load, without overloading the tires. It is recommended that the manufacturer supply tires suitable for the rated wagon load.

**Load Rating Test:** The Dump Chief running gear was subjected to a standard load rating test<sup>3</sup>. It met the test requirements.

**OPERATOR SAFETY**

The 706W Dump Chief was safe to operate, if the manufacturer's safety instructions were followed. Dumping should not be attempted on side slopes greater than 5°. The wagon should be dumped only when alongside a receiving box, and caution should be observed when dumping in high winds. Observers should stand clear during unloading.

Since the tires were overloaded at the manufacturer's rated capacity, low speeds and caution had to be used when transporting a loaded wagon. As well, the manufacturer's maximum recommended fill levels must not be exceeded, or overloading of the running gear and hydraulic cylinders could result. The towing vehicle should be heavy enough and have suitable brakes to permit safe emergency stops during transport.

Maximum height of the Dump Chief during unloading was 6.2 m. Caution must be taken to avoid unloading near power lines. Minimum power line heights vary in the three prairie provinces. In Saskatchewan, the energized line may be as low as 5.2 m over farm land or over secondary roads. In Alberta and Manitoba, the neutral ground wire may be as low as 4.8 m over farm land. In all three provinces, lines in farmyards may be as low as 4.6 m.

**OPERATOR'S MANUAL**

The operator's manual was clear and well written, containing useful information on operation, servicing, adjustment and safety.

**DURABILITY RESULTS**

TABLE 1 outlines the mechanical history of the Dump Chief during 240 hours of field testing and during the standard Load Rating Test. The intent of the test was evaluation of functional performance. The following failures represent those that occurred during functional testing. An extended durability evaluation was not conducted.

**TABLE 1.** Mechanical History

ITEM	OPERATING HOURS
The lower front left box corner buckled during unloading at	21
One control bar for the front bolster stabilizer was bent, requiring straightening at	21
The front wheels required realignment at	49
The rear, hydraulic cylinder internal bypass valve failed and was replaced at	130 and 217
The main bypass valve failed and was replaced at	200
Both control bars for the front bolster stabilizer were bent, requiring straightening at	end of test

**DISCUSSION OF MECHANICAL PROBLEMS**

**Box Corner:** The lower left front box corner buckled, as it failed to align with the front box guide, when the box was lowered after dumping. Box misalignment was caused by loss of synchronization of the two series connected hydraulic cylinders, probably due to malfunction of the bypass valve in the rear cylinder piston.

**Control Bars for Bolster Stabilizer:** The control bars (FIGURE 4) bent several times during the test. It is recommended that the front bolster stabilizer assembly be modified to eliminate bending of the control bars.

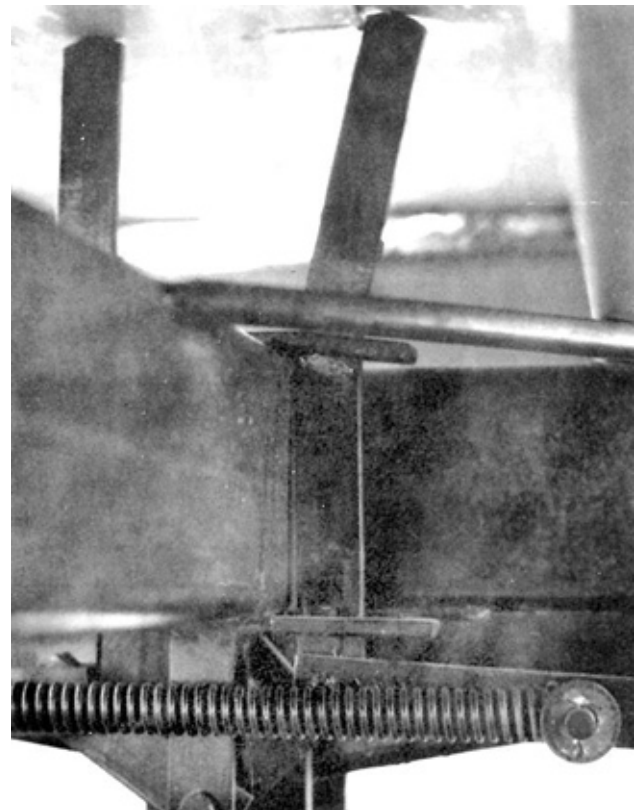

**FIGURE 4.** Bent Control Bars for Front Bolster Stabilizer.

**Hydraulic System:** The 706W Dump Chief used two hydraulic cylinders connected in series. Synchronization of the rear slave cylinder was a recurring problem and occurred in the fully retracted and fully extended positions, with a mechanical bypass valve located in both front and rear cylinder pistons. The two failures of the rear hydraulic cylinder were due to sticking of the internal mechanical bypass valve, causing the rear cylinder to lose synchronization. It is recommended that the hydraulic system be modified to eliminate synchronization problems.

<sup>2</sup>The Tire and Rim Association Inc., 1979 Year Book.

<sup>3</sup>American Society of Agricultural Engineers. Standard, S360 "Test Procedure for Determining the Load Carrying Ability of Farm Wagon Running Gear," December 1974.

## APPENDIX I

### SPECIFICATIONS

<b>Make:</b>	Gilmore Tatge	
<b>Model:</b>	706W Dump Chief	
<b>Serial No.:</b>	544	
<b>Manufacturer:</b>	Gilmore Tatge Manufacturing Co., Ltd.	
<b>Maximum Load Rating:</b>	8.2 t	
<b>Overall Dimensions:</b>		
-- height (with optional forage roof)	3710 mm	
-- height (in full dump position)	6145 mm	
-- width	3270 mm	
-- length (less hitch)	3930 mm	
-- wheel tread	2945 mm	
-- wheel base	2610 mm	
-- ground clearance	255 mm	
<b>Box Dimensions:</b>		
-- width		
• bottom	1200 mm	
• top	3100 mm	
-- height		
• right side	1840 mm	
• left side	2100 mm	
-- length	3520 mm	
-- capacity	14.2 m <sup>3</sup>	
<b>Weight:</b>		
-- left front wheel	532 kg	
-- left rear wheel	580 kg	
-- right front wheel (with 90 kg ballast)	618 kg	
-- right rear wheel (with 90 kg ballast)	<u>536 kg</u>	
TOTAL	2266 kg	
<b>Tires:</b>	Four, 12.5L x 15, 8-ply.	
<b>Lubrication Points:</b>		
-- every 8 hours	3	
-- annually	4	
<b>Bolster Stabilizers</b>	Mechanical	
<b>Hydraulic Cylinders:</b>	<b>Rear</b>	<b>Front</b>
-- rod size	63.5 mm	66.6 mm
-- bore	108.0 mm	127.0 mm
-- retracted length	2150 mm	2150 mm
-- stroke	1890 mm	1890 mm
<b>Optional Equipment:</b>		
-- 610 mm pouring lip kit		
-- 150 mm riser kit		
-- hydraulic hose support bracket		

## APPENDIX II

### MACHINE RATINGS

The following rating scale is used in PAMI Evaluation Reports:

a) excellent	d) fair
b) very good	e) poor
c) good	f) unsatisfactory

## APPENDIX III

### CONVERSION TABLE

1 kilometre/hour (km/h)	=	0.62 mile/hour (mph)
1000 millimetres (mm) = 1 metre (m)	=	39.4 inches (in)
1 kilogram (kg)	=	22 pounds mass (lb)
1 tonne (t)	=	2200 pounds mass (lb)
1 cubic metre (m <sup>3</sup> )	=	35 cubic feet (ft <sup>3</sup> )



3000 College Drive South  
Lethbridge, Alberta, Canada T1K 1L6  
Telephone: (403) 329-1212  
FAX: (403) 329-5562

<http://www.agric.gov.ab.ca/navigation/engineering/afmrc/index.html>

**Prairie Agricultural Machinery Institute**

Head Office: P.O. Box 1900, Humboldt, Saskatchewan, Canada S0K 2A0  
Telephone: (306) 682-2555

Test Stations:

P.O. Box 1060

Portage la Prairie, Manitoba, Canada R1N 3C5

Telephone: (204) 239-5445

Fax: (204) 239-7124

P.O. Box 1150

Humboldt, Saskatchewan, Canada S0K 2A0

Telephone: (306) 682-5033

Fax: (306) 682-5080