

Evaluation Report 721

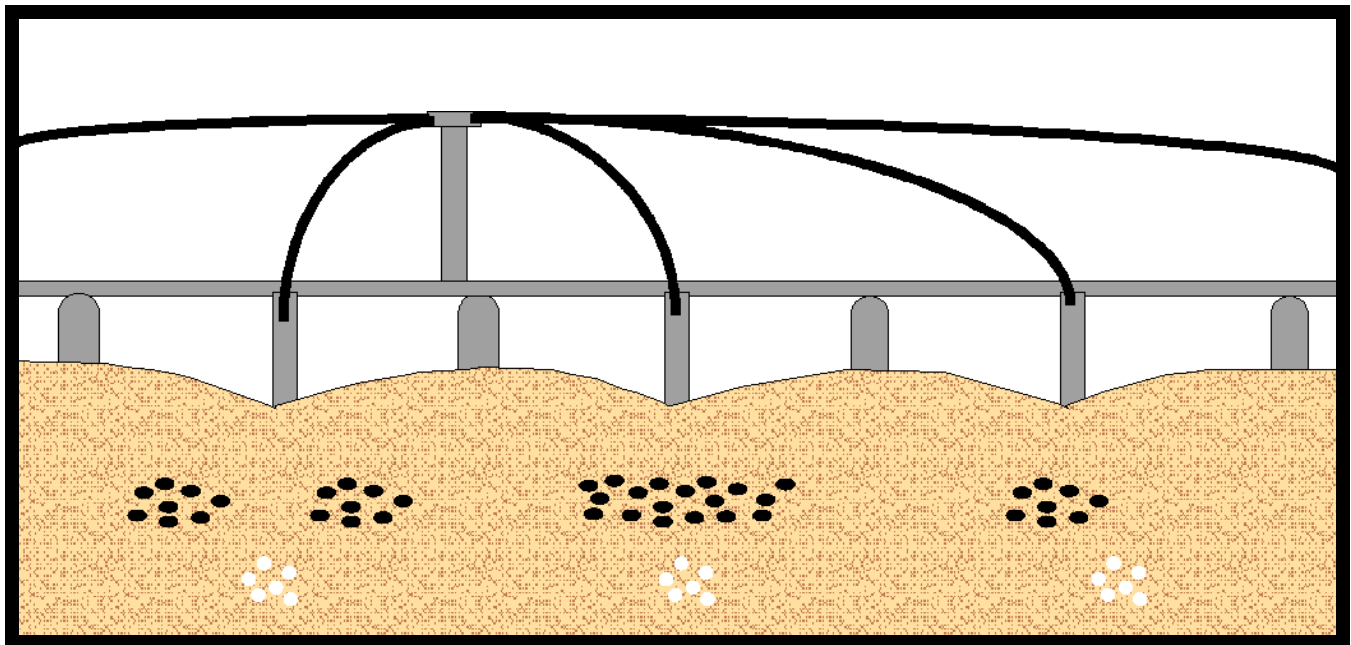

Testing of Double Shoot Opener

A Co-operative Program Between



TESTING OF DOUBLE SHOOT OPENERS

INTRODUCTION

Direct seeding has become very popular over the last few years. One of the limitations of direct seeding is the ability to apply the required amount of fertilizer. Several manufacturers have developed openers which separate the seed and fertilizer. Double shoot openers allow the application of large amounts of fertilizer while seeding. Knowledge and experience on the operation of these openers is limited. A project to test the double shoot openers was started by the Alberta Farm Machinery Research Centre in the Summer of 1993 and completed in 1994.

TEST PROCEDURE

Testing of the double shoot openers was split into two parts. First, was the operation of the openers in the Alberta Soil Bin Test Facility. Horizontal, vertical, lateral soil forces, and seed and fertilizer placement were measured during operation of the openers in the soil bin.

Dimensions of the soil bin are 58 ft (17.7 m) long, 10 ft (3.1 m) wide and 24 in (610 mm) deep. The bin contains a sandy and a clay loam soil. Each type of soil has a useable length of 20 ft (6.1 m). A carriage is mounted on rails and pulled up and down the bin electrically. The carriage contains an instrumented, adjustable frame where a soil opener is mounted. A metering system and a fan deliver the material to the soil openers. Pot barley is used to simulate the seed and fertilizer in the soil bin.

The second part was the operation of the openers in the field. The openers were mounted on a mini air seeder and used in fields around the Lethbridge area for 4 to 5 ac (1.6 to 2 ha) per opener. The soil ranged from clay loam to clay. Seed and fertilizer placement, draft and vertical force were measured during operation of the openers in the field.

The mini air seeder consists of a tow-between air delivery cart and an 8 ft (2.4 m) wide cultivator. The cultivator has four rows of shanks and a floating hitch. The air delivery system is a Gandy applicator. Eight shanks were mounted on the mini air seeder.

DESCRIPTION

Fifteen different double shoot openers from nine manufacturers were included in the test. There are three main types of double shoot openers.

- 1) Single Row: The fertilizer is placed directly below a single seed row.
- 2) Single Row and Side Band: The fertilizer is placed below and to the side of a single seed row.
- 3) Pair Row: The fertilizer is placed between and at the same depth or below two rows of seed.

Single Row Openers Tested

- Key Ag Ventures Four Inch Chrome with Backswept Knife
- New Noble Nutriband System

Single Row and Side Band Openers

- Dutch Vern-Eagle Buster Combination
- Flexi-coil Side Band Double Shoot Knife Opener
- Gen 200 T2 Seeding System
- Morris Conventional Double Shoot Opener
- Morris Edge-on Double Shoot Opener
- Poirier Double Shoot Opener
- Swede Dual Placement Opener

Pair Row Openers Tested:

- Anderson Opener
- Flexi-coil HS Paired Row Double Shoot Knife Opener
- Gen 200 T2X2 Seeding System
- Key Ag Ventures Key Two Seeding System
- Key Ag Ventures Seven Inch Chrome with Backswept Knife
- New Noble Seed-o-Vator System

DISCUSSION

FIGURE 1 describes the measurements listed in the TABLES in the following reports.

The Key Ag Ventures Key Two system, Key Ag Ventures Seven Inch Chrome with Backswept Knife and the Gen 200 T2X2 seeding system were mounted on a 12 in (305 mm) spacing during the field test. The other nine openers were mounted on a 10 in (254 mm) spacing.

The Anderson opener, New Noble Seed-o-Vator system and the New Noble Nutriband system were not available for field testing. The reports on these openers are based only on the soil bin results.

The horsepower ratings in the report do not account for tractive and tractor efficiency and the rolling resistance of the seeding unit. Tractive efficiency is normally 80 percent for hard soils and 70 percent for loose soils. Tractor efficiency is normally 80 percent. Rolling resistance of the seeding unit is 10 hp (7.5 kW) for air delivery tanks and 0.5 hp/ft (1.2 kW/m) for packers.

The wear tests in the circular soil bin were not completed by the publishing date of this report. The results of the wear tests will be available at a later date.

Two other openers were tested but the results were not published due to unsatisfactory results.

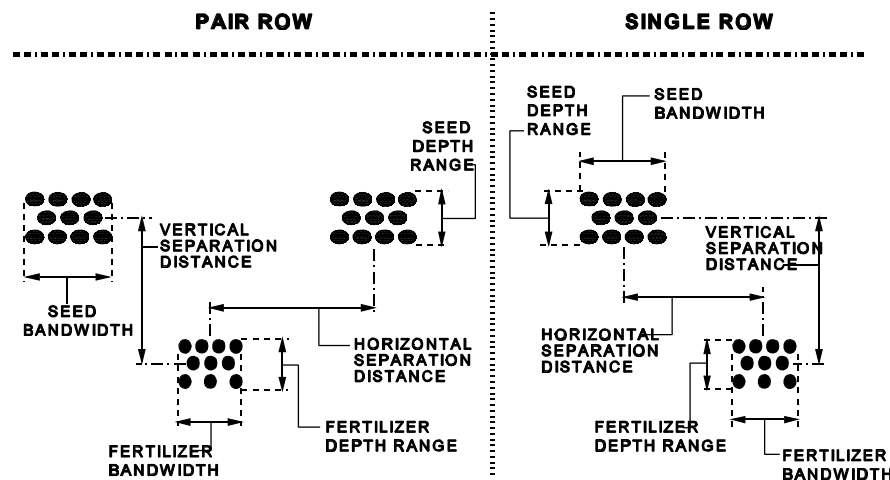

Figure 1. Explanation of figures in the following report's TABLES.

ANDERSON OPENER

MANUFACTURER:

Anderson Machine Inc.
 P.O. Box 32
 Andover, South Dakota USA 57422
 Phone: (605) 298-5663

RETAIL PRICE: (March, 1995)

\$113.00 U.S. for Anderson Opener.
 \$20.00 U.S. for Replacement Point.

GENERAL DESCRIPTION

The Anderson opener is a pair row type opener (FIGURE 1). The opener consists of a front fertilizer point, fertilizer delivery tubes, packing plate and seed delivery tubes. The packing plate is located behind the fertilizer delivery tubes. The granular and anhydrous ammonia fertilizer delivery tubes and pair row and single seed delivery tubes are welded to the shank mount. The front fertilizer point is connected to the shank mount with a roll pin. The packing plate bolts to the bottom of the shank mount. The packing plate is plastic with steel wear bars bolted to the sides. Plastic is riveted to each side of the opener. The opener mounts on a special edge-on shank. Mounts for conventional shanks are also available.

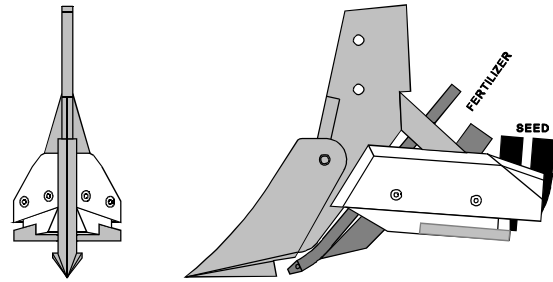

Figure 1. Anderson Opener.

RESULTS AND DISCUSSION

NOTE: The following results are based on soil bin results only. The opener was not available for field testing.

Seed and Fertilizer Placement: The average seed and fertilizer placement was as listed in TABLE 1 and shown in FIGURE 2. The seed band width was the same for the single and pair row seed delivery tubes. The dividing of the seed by the pair row seed delivery tube was not accurate. The amount delivered on one side of the pair row tube was 20 percent more than the amount delivered on the other side.

Table 1. Seed and Fertilizer Placement.

PLACEMENT	in	mm
Seed Depth Range	0.6	15
Fertilizer Depth Range	0.4	10
Seed Band Width	3.9	99
Fertilizer Band Width	0.6	15
Vertical Separation	1.6	41
Horizontal Separation	0.0	00

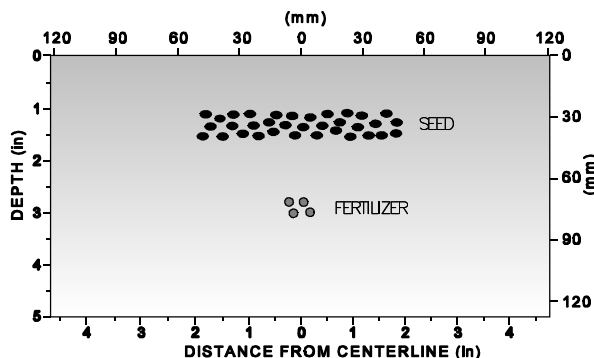

Figure 2. Seed and fertilizer placement.

DRAFT AND POWER REQUIREMENTS

Average draft (drawbar pull) ranged from 180 to 200 lb (801 to 890 N) over a 3.5 to 4 in (89 to 102 mm) tillage depth. For comparison, the average draft for a 12 in (305 mm) wide sweep opener ranged from 215 to 280 lb (957 to 1246 N) over a 3 to 3.5 in (76 to 89 mm) tillage depth.

The drawbar power needed to operate each opener at 5 mph (8 km/h) varied from 2.4 to 2.7 hp (1.8 to 2 kW). For comparison, the drawbar power needed to operate a 12 in (305 mm) wide sweep opener varied from 2.9 to 3.7 hp (2.2 to 2.8 kW). Increases in ground speed increased the power requirements.

VERTICAL FORCES

The soil exerted an average upward force of 20 lb (89 N) on the opener. The weight of the cultivator or drill and openers must overcome these upward forces. For comparison, the soil exerted an average downward or suction force of 50 lb (223 N) on a 12 in (305 mm) wide sweep opener.

INSTALLATION

Ease of installing the one piece opener on the edge-on shank was good. Standard 0.5 x 2.25 in (13 x 57 mm) or longer hexagon head bolts were used to mount the opener. The seed delivery tubes were 1 in (25 mm) OD. The granular fertilizer delivery tube was 1.25 in (32 mm) OD. The anhydrous ammonia delivery tube was 9/16 in (14 mm) OD. No installation or operation instructions were provided.

SPECIFICATIONS

Mounted Dimensions

- Height 12 in (305 mm)
- Width 5.5 in (140 mm)
- Length 18.4 in (467 mm)
- Depth below shank 8 in (203 mm)

Weight

15.4 lb (7 kg)

DUTCH VERN EAGLEBUSTER COMBINATION

MANUFACTURER:

Dutch Industries
705 1 Avenue
Regina, Saskatchewan S4N 4M4
Phone: (306) 949-9522

RETAIL PRICE: (March, 1995)

\$57.40 for Dutch Vern Eaglebuster Combination.
\$8.90 for Replacement Point.

GENERAL DESCRIPTION

The Dutch Vern Eaglebuster Combination is a single row, side band type opener (FIGURE 1). The opener consists of a front fertilizer knife and a backswept knife. The fertilizer knife bolts to the front of the shank. The backswept knife assembly bolts to the back of the shank. The fertilizer point and blade for the backswept knife are secured by roll pins. The height of the backswept knife assembly is adjustable with three different positions. The opener mounts on 50 degree chisel plow shanks.

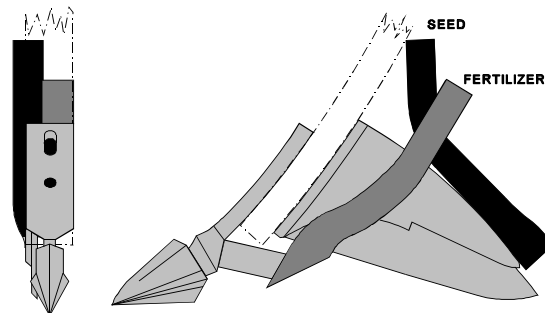

Figure 1. Dutch Vern Eaglebuster Combination.

RESULTS AND DISCUSSION

Seed and Fertilizer Placement: The average seed and fertilizer placement was as listed in TABLE 1 and shown in FIGURE 2. The backswept knife was mounted in the top position during the test. Mounting the backswept knife in the middle position resulted in less separation. Mounting the backswept knife in the bottom position usually resulted in mixing of the seed and fertilizer.

Table 1. Seed and Fertilizer Placement.

PLACEMENT	in	mm
Seed Depth Range	0.4	10
Fertilizer Depth Range	0.4	10
Seed Band Width	0.8	20
Fertilizer Band Width	1.0	25
Vertical Separation	1.4	36
Horizontal Separation	1.0	25

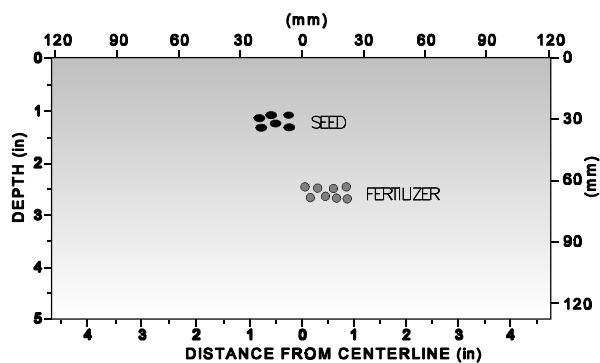

Figure 2. Seed and fertilizer placement.

DRAFT AND POWER REQUIREMENTS

Average draft (drawbar pull) ranged from 130 to 255 lb (579 to 1135 N) over a 3 to 3.5 in (76 to 89 mm) tillage depth. For comparison, the average draft for a 12 in (305 mm) wide sweep opener ranged from 215 to 280 lb (957 to 1246 N) over a 3 to 3.5 in (76 to 89 mm) tillage depth.

The drawbar power needed to operate each opener at 5 mph (8 km/h) varied from 1.7 to 3.4 hp (1.3 to 2.6 kW). For comparison, the drawbar power needed to operate a 12 in (305 mm) wide sweep opener varied from 2.9 to 3.7 hp (2.2 to 2.8 kW). Increases in ground speed increased the power requirements.

VERTICAL AND LATERAL FORCES

The soil exerted an average downward or suction force of 10 lb (45 N) on the opener. The flotation of the cultivator or drill must overcome these downward forces. For comparison, the soil exerted an average downward or suction force of 50 lb (223 N) on a 12 in (305 mm) wide sweep opener.

The soil exerted an average lateral force of 10 lb (45 N) on the opener. Skewing was not a problem with the openers during the test.

INSTALLATION

Ease of installing the opener on a shank was fair. Mounting the openers required holding pieces on the front and back of the shank and placing the bolts in position. The bolt spacing was variable from 1.75 to 2.5 in (44 to 64 mm). Standard 0.5 x 3.75 in (13 x 95 mm) hexagon head bolts were used to mount the opener. The delivery tube inlets were 1.25 in (32 mm) OD. No installation or operation instructions were provided.

SPECIFICATIONS

Mounted Dimensions

-Height	11.9 in (302 mm)
-Width	3.4 in (86 mm)
-Length	17.5 in (445 mm)
-Depth below shank	3.9 in (99 mm)
Weight	12.3 lb (5.6 kg)

FLEXI-COIL HS PAIRED ROW DOUBLE SHOOT KNIFE OPENER

MANUFACTURER:

Flexi-coil
 P.O. Box 1928
 Saskatoon, Saskatchewan S7K 3S5
 Phone: (306) 934-3500

RETAIL PRICE: (March, 1995)

\$60.00 (f.o.b. Lethbridge, Alberta) for Flexi-coil HS Paired Row Double Shoot Knife Opener.

\$16.30 for Replacement Point.

GENERAL DESCRIPTION

The Flexi-coil HS Paired Row Double Shoot Knife opener is a pair row type opener (FIGURE 1). The opener consists of a front fertilizer knife followed by a pair row seed blade. The fertilizer knife bolts to the front of the shank. The seed blade is attached to the back of the fertilizer knife with a bolt and nut, and a spring pin. Two different seed blades are available. The "HS" blade is used in loam to heavy soils and the "LS" blade is used in sandy to light loam soils. Two different replaceable fertilizer knife tips are available. The standard tip is secured to the knife with a roll pin. The heavy duty tip has two pieces of flat metal welded to the sides and is secured to the knife with a bolt and nut. The opener mounts on 50 degree chisel plow shanks that are built according to ASAE Standards. An aluminum shim is available to correct the opener for small variations in shank angles. An adapter is available to mount the opener to a field cultivator shank built according to ASAE Standards. The HS seed blade and heavy duty fertilizer knife tip were used during the test.

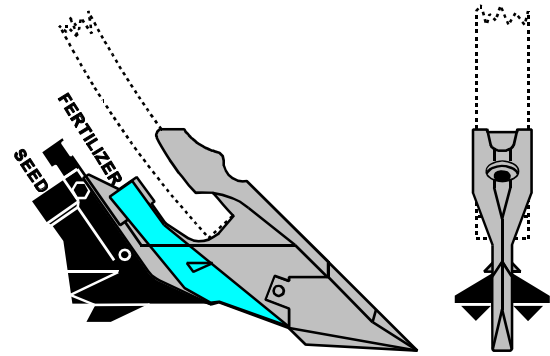

Figure 1. Flexi-coil HS Paired Row Double Shoot Knife Opener.

RESULTS AND DISCUSSION

Seed and Fertilizer Placement: The manufacturer recommended that the opener be mounted so the bottom edge of the seed blade is parallel to the soil surface. The aluminum shims were used to mount the openers so the seed blades were parallel to the soil surface. The average seed and fertilizer placement was as listed in TABLE 1 and shown in FIGURE 2. One seed row was formed in most soil conditions except moist soils where two distinct rows were formed. The dividing of the seed by the seed blade was accurate. The amount delivered from one side of the blade was within 5 percent of the amount delivered from the other side.

Table 1. Seed and Fertilizer Placement.

PLACEMENT	in	mm
Seed Depth Range	0.8	20
Fertilizer Depth Range	0.6	15
Seed Band Width	2.6	66
Fertilizer Band Width	0.8	20
Vertical Separation	1.2	30
Horizontal Separation	0.0	00

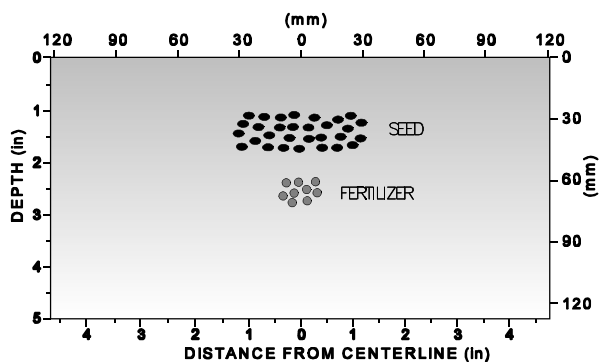

Figure 2. Seed and fertilizer placement.

DRAFT AND POWER REQUIREMENTS

Average draft (drawbar pull) ranged from 115 to 200 lb (512 to

890 N) over a 3 to 3.5 in (76 to 89 mm) tillage depth. For comparison, the average draft for a 12 in (305 mm) wide sweep opener ranged from 215 to 280 lb (957 to 1246 N) over a 3 to 3.5 in (76 to 89 mm) tillage depth.

The drawbar power needed to operate each opener at 5 mph (8 km/h) varied from 1.5 to 2.7 hp (1.1 to 2 kW). For comparison, the drawbar power needed to operate a 12 in (305 mm) wide sweep opener varied from 2.9 to 3.7 hp (2.2 to 2.8 kW). Increases in ground speed increased the power requirements.

VERTICAL FORCES

The soil exerted an average downward or suction force of 20 lb (89 N) on the opener. The flotation of the cultivator or drill must overcome these downward forces. For comparison, the soil exerted an average downward or suction force of 50 lb (223 N) on a 12 in (305 mm) wide sweep opener.

INSTALLATION

Ease of installing the opener on a shank was good. The bolt spacing was 2 in (51 mm) for 0.5 in (13 mm) bolts and 1.5 in (38 mm) for 7/16 in (11 mm) bolts. Standard hexagon head bolts were used to mount the opener. Required bolt lengths were 2.5 in (64 mm) and 2.75 in (70 mm). The delivery tube inlets were 1.25 in (32 mm) ID. A vertical tab between the two inlet tubes was used to secure the delivery hoses with hose clamps. Several delivery hoses came out of the tubes in wet heavy residue field conditions. A reference sheet on installation and operation was provided with each opener.

SPECIFICATIONS

Mounted Dimensions	
-Height	9 in (229 mm)
-Width	3.8 in (97 mm)
-Length	15 in (381 mm)
-Depth below shank	5.3 in (135 mm)
Weight	12.5 lb (5.7 kg)

FLEXI-COIL SIDE BAND DOUBLE SHOOT KNIFE OPENER

MANUFACTURER:

Flexi-coil
 P.O. Box 1928
 Saskatoon, Saskatchewan S7K 3S5
 Phone: (306) 934-3500

RETAIL PRICE: (March, 1995)

\$52.00 (f.o.b. Lethbridge, Alberta) for Flexi-coil Side Band Double Shoot Knife Opener.

\$16.30 for Replacement Point.

GENERAL DESCRIPTION

The Flexi-coil Side Band Double Shoot Knife opener is a single row, side band type opener (FIGURE 1). The opener consists of a front fertilizer knife followed by a seed blade. The fertilizer knife bolts to the front of the shank. The seed blade is attached to the back of the fertilizer knife with a bolt and nut and a spring pin. Two different replaceable fertilizer knife tips are available. The standard tip is secured to the knife with a roll pin. The heavy duty tip has two pieces of flat metal welded to the sides and is secured to the knife with a bolt and nut. The opener mounts on 50 degree chisel plow shanks that are built according to ASAE Standards. An aluminum shim is available to correct the opener for small variations in shank angles. An adapter is available to mount the opener to a field cultivator shank built according to ASAE Standards. The heavy duty fertilizer knife tip was used during the test.

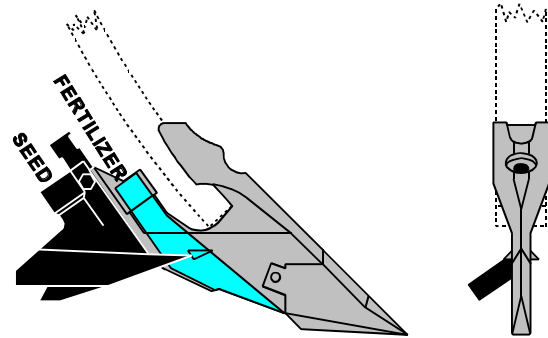

Figure 1. Flexi-coil Side Band Double Shoot Knife Opener.

RESULTS AND DISCUSSION

Seed and Fertilizer Placement: The manufacturer recommended that the opener be mounted so the bottom edge of the seed blade is parallel to the soil surface. The aluminum shims were used to mount the openers so the seed blades were parallel to the soil surface. The average seed and fertilizer placement was as listed in TABLE 1 and shown in FIGURE 2.

Table 1. Seed and Fertilizer Placement.

PLACEMENT	in	mm
Seed Depth Range	0.8	20
Fertilizer Depth Range	0.6	15
Seed Band Width	1.4	36
Fertilizer Band Width	0.8	20
Vertical Separation	1.2	30
Horizontal Separation	1.2	30

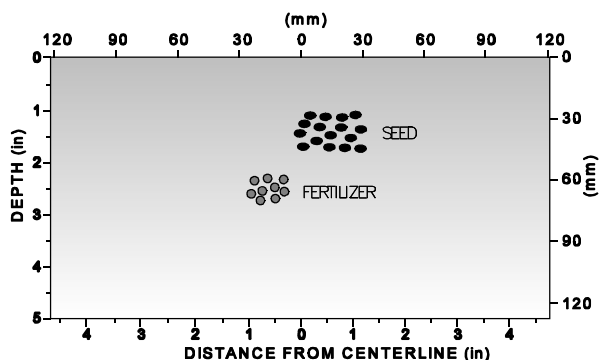

Figure 2. Seed and fertilizer placement.

DRAFT AND POWER REQUIREMENTS

Average draft (drawbar pull) ranged from 115 to 170 lb (512 to 757 N) over a 3 to 3.5 in (76 to 89 mm) tillage depth. For comparison, the average draft for a 12 in (305 mm) wide sweep opener ranged from 215 to 280 lb (957 to 1246 N) over a 3 to 3.5 in (76 to 89 mm) tillage depth.

The drawbar power needed to operate each opener at 5 mph (8 km/h) varied from 1.5 to 2.3 hp (1.1 to 1.7 kW). For comparison, the drawbar power needed to operate a 12 in (305 mm) wide sweep opener varied from 2.9 to 3.7 hp (2.2 to 2.8 kW). An increase in ground speed increased the power requirements.

VERTICAL AND LATERAL FORCES

The soil exerted an average downward or suction force of 20 lb (89 N) on the opener. The flotation of the cultivator or drill must overcome these downward forces. For comparison, the soil exerted an average downward or suction force of 50 lb (223 N) on a 12 in (305 mm) wide sweep opener.

The soil exerted an average lateral force of 5 lb (22 N) on the opener. The manufacturer supplies left and right openers to counteract the lateral force. Equal number of left and right openers should be used on the cultivator or drill.

INSTALLATION

Ease of installing the opener on a shank was good. The bolt spacing was 2 in (51 mm) for 0.5 in (13 mm) bolts and 1.5 in (38 mm) for 7/16 in (11 mm) bolts. Standard hexagon head bolts were used to mount the opener. Required bolt lengths were 2.5 in (64 mm) and 2.75 in (70 mm). The delivery tube inlets were 1.25 in (32 mm) ID. A vertical tab between the two inlet tubes was used to secure the delivery hoses with hose clamps. Several delivery hoses came out of the tubes in wet heavy residue field conditions. A reference sheet was provided with each opener. The sheet contained information on installation and operation.

SPECIFICATIONS

Mounted Dimensions

-Height	9 in (229 mm)
-Width	3.3 in (84 mm)
-Length	15.5 in (394 mm)
-Depth below shank	5.3 in (135 mm)
Weight	12.1 lb (5.5 kg)

GEN 200 T2 SEEDING SYSTEM

MANUFACTURER:

Gen Manufacturing Ltd.
 P.O. Box 560
 Coaldale, Alberta T1M 1M5
 Phone: (403) 345-3414

RETAIL PRICE: (March, 1995)

\$58.65 for GEN 200 T2 Seeding System.
 \$13.80 for Replacement Point.

GENERAL DESCRIPTION

The Gen 200 T2 seeding system is a single row, side band type opener (FIGURE 1). The opener consists of four pieces held together with a bolt and roll pins. The front point creates a furrow for the fertilizer. A wing on the right side of the point creates a furrow for the seed. The back piece delivers the seed and fertilizer. A replaceable wear piece on the bottom of the back piece is held in place by the front point. The front point and back piece are secured to a vertical piece with roll pins. The vertical piece is bolted to the shank mount with a single bolt. The opener mounts on the front of 50 degree chisel plow shanks with the use of a shim. An offset holder is available to place the opener to the side of the shank. A spacer is not required for the offset holder.

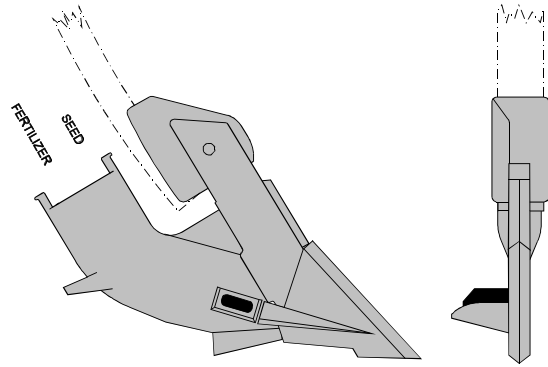

Figure 1. GEN 200 T2 Seeding System.

RESULTS AND DISCUSSION

Seed and Fertilizer Placement: The manufacturer recommended that the opener be mounted so the bottom edge of the back piece was 1/8 in (3.2 mm) higher than the bottom edge of the front point. The average seed and fertilizer placement was as listed in TABLE 1 and shown in FIGURE 2.

Table 1. Seed and Fertilizer Placement.

PLACEMENT	in	mm
Seed Depth Range	0.8	20
Fertilizer Depth Range	0.4	10
Seed Band Width	1.6	41
Fertilizer Band Width	0.8	20
Vertical Separation	1.6	41
Horizontal Separation	2.0	51

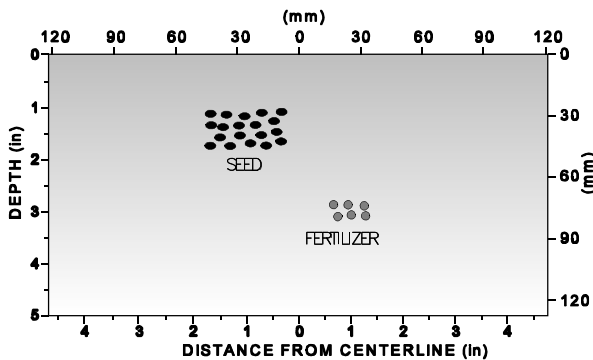

Figure 2. Seed and fertilizer placement.

DRAFT AND POWER REQUIREMENTS

Average draft (drawbar pull) ranged from 200 to 320 lb (890 to 1424 N) over a 3.5 to 4 in (89 to 102 mm) tillage depth. For comparison, the average draft for a 12 in (305 mm) wide sweep opener ranged from 215 to 280 lb (957 to 1246 N) over a 3 to 3.5 in (76 to 89 mm) tillage depth.

The drawbar power needed to operate each opener at 5 mph (8 km/h) varied from 2.7 to 4.3 hp (2 to 3.2 kW). For comparison, the drawbar power needed to operate a 12 in (305 mm) wide sweep opener varied from 2.9 to 3.7 hp (2.2 to 2.8 kW). Increases in ground speed increased the power requirements.

VERTICAL AND LATERAL FORCES

The soil exerted an average upward force of 10 lb (45 N) on the opener. The weight of the cultivator or drill and openers must overcome these upward forces. For comparison, the soil exerted an average downward or suction force of 50 lb (223 N) on a 12 in (305 mm) wide sweep opener.

The soil exerted an average lateral force of 15 lb (67 N) on the opener. Skewing was not a problem with the openers during the test.

INSTALLATION

Ease of installing the opener on a shank was fair. The procedure for mounting the opener was to install the shank mount first. The rest of the opener was mounted before the plow bolts were tightened. The bottom bolt hole on the shank mount was slotted. The bolt spacing was variable from 1.75 to 2.5 in (44 to 64 mm). Standard 0.5 in (13 mm) plow bolts were used to mount the opener. Required bolt lengths were 2.25 in (57 mm) and 2.75 in (70 mm) to mount on the 50 degree shank. The delivery tube inlets were 1.4 in (36 mm) ID. Vertical tabs on each delivery hose inlet were used to secure the delivery hoses with hose clamps. An installation instruction sheet was provided with the openers.

SPECIFICATIONS

Mounted Dimensions

-Height	12.3 in (312 mm)
-Width	4.4 in (112 mm)
-Length	16.5 in (419 mm)
-Depth below shank	6 in (152 mm)
Weight	20.7 lb (9.4 kg)

GEN 200 T2X2 SEEDING SYSTEM

MANUFACTURER:

Gen Manufacturing Ltd.
 P.O. Box 560
 Coaldale, Alberta T1M 1M5
 Phone: (403) 345-3414

RETAIL PRICE: (March, 1995)

\$75.00 for GEN 200 T2X2 Seeding System.
 \$16.75 for Replacement Point.

GENERAL DESCRIPTION

The Gen 200 T2X2 seeding system is a pair row type opener (FIGURE 1). The opener consists of four pieces held together with a bolt and roll pins. The front point creates a furrow for the fertilizer. Wings on each side of the point create furrows for the seed. The back piece delivers the seed and fertilizer. A replaceable wear piece on the bottom of the back piece is held in place by the front point. The front point and back piece are secured to a vertical piece with roll pins. The vertical piece is bolted to the shank mount with a single bolt. The opener mounts on the front of 50 degree chisel plow shanks with the use of a shim.

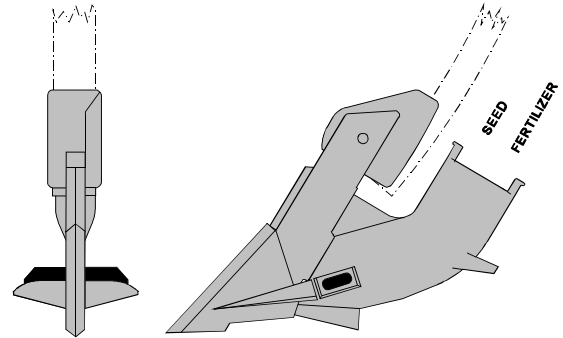

Figure 1. GEN 200 T2X2 Seeding System.

RESULTS AND DISCUSSION

Seed and Fertilizer Placement: The manufacturer recommended that the opener be mounted so the bottom edge of the back piece was 1/8 in (3.2 mm) higher than the bottom edge of the front point. The average seed and fertilizer placement was as listed in TABLE 1 and shown in FIGURE 2. The dividing of the seed by the back piece was accurate. The amount delivered from one side of the piece was within 5 percent of the amount delivered from the other side.

Table 1. Seed and Fertilizer Placement.

PLACEMENT	in	mm
Seed Depth Range	1.0	25
Fertilizer Depth Range	0.4	10
Seed Band Width	1.6	41
Fertilizer Band Width	0.8	20
Vertical Separation	1.6	41
Horizontal Separation	2.0	51

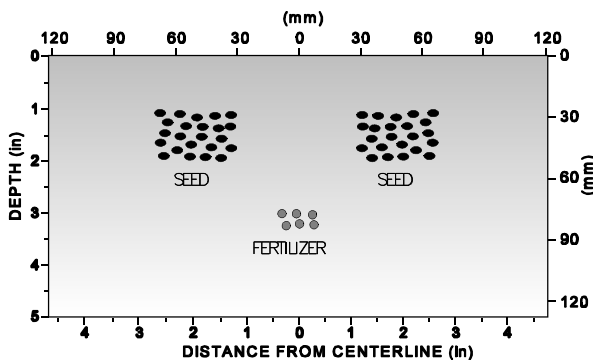

Figure 2. Seed and fertilizer placement.

DRAFT AND POWER REQUIREMENTS

Average draft (drawbar pull) ranged from 200 to 320 lb (890 to 1424 N) over a 3.5 to 4 in (89 to 102 mm) tillage depth. For comparison, the average draft for a 12 in (305 mm) wide sweep opener ranged from 215 to 280 lb (957 to 1246 N) over a 3 to 3.5 in (76 to 89 mm) tillage depth.

The drawbar power needed to operate each opener at 5 mph (8 km/h) varied from 2.7 to 4.3 hp (2 to 3.2 kW). For comparison, the drawbar power needed to operate a 12 in (305 mm) wide sweep opener varied from 2.9 to 3.7 hp (2.2 to 2.8 kW). Increases in ground speed increased the power requirements.

VERTICAL FORCES

The soil exerted an average downward or suction force of 30 lb (134 N) on the opener. The flotation of the cultivator or drill must overcome these downward forces. For comparison, the soil exerted an average downward or suction force of 50 lb (223 N) on a 12 in (305 mm) wide sweep opener.

INSTALLATION

Ease of installing the opener on a shank was fair. The procedure for mounting the opener was to install the shank mount first. The rest of the opener was mounted before the plow bolts were tightened. The bottom bolt hole on the shank mount was slotted. The bolt spacing was variable from 1.75 to 2.5 in (44 to 64 mm). Standard 0.5 in (13 mm) plow bolts were used to mount the opener. Required bolt lengths were 2.25 in (57 mm) and 2.75 in (70 mm) to mount on the 50 degree shank. The delivery tube inlets were 1.4 in (36 mm) ID. Vertical tabs on each delivery hose inlet were used to secure the delivery hoses with hose clamps. An installation instruction sheet was provided with the openers.

MECHANICAL HISTORY

Roll pins that secured the front point on four of the openers moved out of the holes during field testing. The manufacturer supplied bolts and nuts to replace the roll pins. The manufacturer plans to modify the casting to better accommodate the bolt and nut mounting of the front point.

SPECIFICATIONS

Mounted Dimensions	
-Height	12.3 in (312 mm)
-Width	6 in (152 mm)
-Length	16.5 in (419 mm)
-Depth below shank	6 in (152 mm)
Weight	21.8 lb (9.9 kg)

KEY AG VENTURES KEY TWO SEEDING SYSTEM

MANUFACTURER:

Key Ag Ventures
 4630 61 Street
 Red Deer, Alberta T4N 2R2
 Phone: (403) 343-6342

NOTE: The Key Two Seeding System is no longer available from the manufacturer.

GENERAL DESCRIPTION

The Key Ag Ventures Key Two seeding system is a pair row type opener (FIGURE 1). The opener consists of a front knife to place the fertilizer and two backswept knives to place the seed. The backswept knives are equal distance on either side of the front knife. The backswept knives and seed boots are bolted to the shank mount. Slotted mounting holes in the backswept knives allow variation in depth with respect to the front point. The fertilizer wear point is connected to the shank mount by a roll pin. The opener mounts on 50 degree chisel plow shanks. A plastic "Y" is supplied with the opener to mount in the delivery hose line and divide the seed.

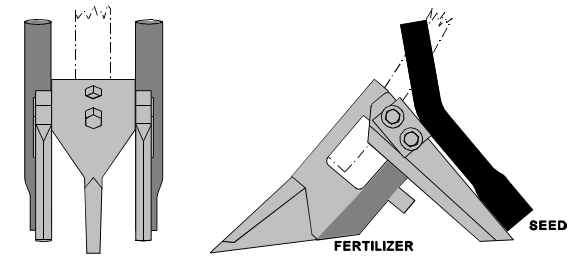

Figure 1. Key Ag Ventures Key Two Seeding System.

RESULTS AND DISCUSSION

Seed and Fertilizer Placement: The manufacturer recommended that the backswept knives be mounted in the highest position and lowered as the knives wear off. The average seed and fertilizer placement was as listed in TABLE 1 and shown in FIGURE 2. Plugging of the seed tubes occurred regularly in wet soil conditions.

The dividing of the seed by the plastic "Y" was not accurate. The amount delivered on one side of the pair row tube ranged from 3 to 14 percent more than the amount delivered on the other side. Angling the delivery hose distributed up to 40 percent more seed to the delivery hose side. Operators should ensure when attaching delivery hoses that they are straight.

Table 1. Seed and Fertilizer Placement.

PLACEMENT	in	mm
Seed Depth Range	0.6	15
Fertilizer Depth Range	0.8	20
Seed Band Width	1.2	30
Fertilizer Band Width	1.4	36
Vertical Separation	1.0	25
Horizontal Separation	2.4	61

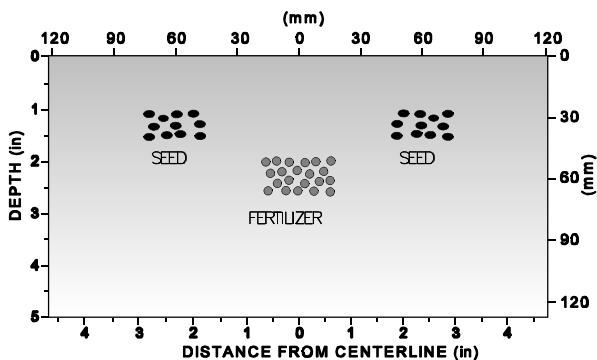

Figure 2. Seed and fertilizer placement.

DRAFT AND POWER REQUIREMENTS

Average draft (drawbar pull) ranged from 135 to 390 lb (601 to 1736 N) over a 3 to 4 in (76 to 102 mm) tillage depth. For comparison, the average draft for a 12 in (305 mm) wide sweep opener ranged from 215 to 280 lb (957 to 1246 N) over a 3 to 3.5 in (76 to 89 mm) tillage depth.

The drawbar power needed to operate each opener at 5 mph (8 km/h) varied from 1.8 to 5.2 hp (1.4 to 3.9 kW). For comparison, the drawbar power needed to operate a 12 in (305 mm) wide sweep opener varied from 2.9 to 3.7 hp (2.2 to 2.8 kW). Increases in ground speed increased the power requirements.

VERTICAL FORCES

The soil exerted an average upward force of 30 lb (134 N) on the opener. The force increased to 70 lb (312 N) after the backswept knives were worn. The weight of the cultivator or drill and openers must overcome these upward forces. For comparison, the soil exerted an average downward or suction force of 50 lb (223 N) on a 12 in (305 mm) wide sweep opener.

INSTALLATION

Ease of installing the opener on a shank was good. The bolt spacing was variable from 1.5 to 2.25 in (38 to 57 mm). Standard 0.5 x 3 in (13 x 76 mm) hexagon head bolts were used to mount the opener. Two 0.5 x 2.25 in (13 x 57 mm) plow bolts were used to mount each backswept knife and delivery tube. The seed and fertilizer delivery tube inlets were 1.25 in (32 mm) ID. A vertical tab on the fertilizer delivery tube inlet was used to secure the delivery hose with a hose clamp. No installation or operation instructions were provided.

SPECIFICATIONS

Mounted Dimensions	
-Height	13.4 in (340 mm)
-Width	8 in (203 mm)
-Length	18.3 in (465 mm)
-Depth below shank	5.8 in (147 mm)
Weight	25.6 lb (11.6 kg)

KEY AG VENTURES FOUR INCH CHROME WITH BACKSWEPT KNIFE

MANUFACTURER:

Key Ag Ventures
 4630 61 Street
 Red Deer, Alberta T4N 2R2
 Phone: (403) 343-6342

RETAIL PRICE: (March, 1995)

\$23.00 4 in (102 mm) Chrome Sweep
 23.00 SB1 Seed Boot
 11.00 Backswept Knife
 9.00 Granular Fertilizer Tube
 \$66.00 TOTAL

GENERAL DESCRIPTION

The Key Ag Ventures Four Inch Chrome with Backswept Knife is a single row type opener (FIGURE 1). The opener consists of a chrome sweep, air seeder spreader boot, backswept knife and a fertilizer delivery tube. The spreader boot delivers the seed behind the chrome sweep. The chrome sweep mounts to the front of the shank and the spreader boot to the back. The backswept knife bolts to the back of the spreader boot. The length of the backswept knife below the chrome sweep is adjustable. The opener mounts on 50 degree chisel plow shanks.

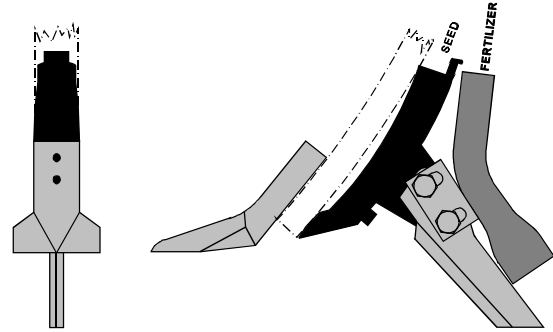

Figure 1. Key Ag Four Inch Chrome With Backswept Knife.

RESULTS AND DISCUSSION

Seed and Fertilizer Placement: The manufacturer recommended that the backswept knife be mounted in the highest position and lowered as the knife wears off. The average seed and fertilizer placement was as listed in FIGURE 1 and shown in FIGURE 2.

Table 1. Seed and Fertilizer Placement.

PLACEMENT	in	mm
Seed Depth Range	0.6	15
Fertilizer Depth Range	0.8	20
Seed Band Width	3.5	89
Fertilizer Band Width	0.8	20
Vertical Separation	2.0	51
Horizontal Separation	0.0	00

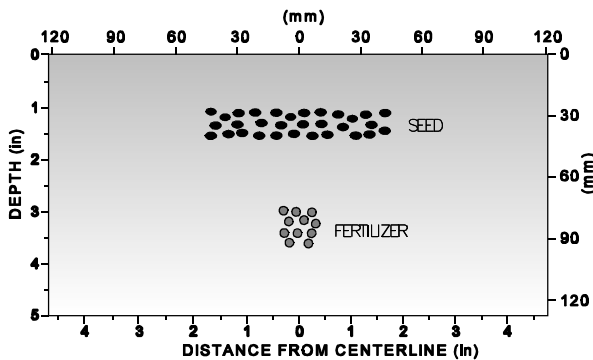

Figure 2. Seed and fertilizer placement.

DRAFT AND POWER REQUIREMENTS

Average draft (drawbar pull) ranged from 300 to 425 lb (1335 to 1891 N) over a 5.5 to 6 in (140 to 152 mm) tillage depth. For comparison, the average draft for a 12 in (305 mm) wide sweep opener ranged from 215 to 280 lb (957 to 1246 N) over a 3 to 3.5 in (76 to 89 mm) tillage depth.

The drawbar power needed to operate each opener at 5 mph (8 km/h) varied from 4 to 5.7 hp (3 to 4.3 kW). For comparison, the drawbar power needed to operate a 12 in (305 mm) wide sweep opener varied from 2.9 to 3.7 hp (2.2 to 2.8 kW). Increases in ground speed increased the power requirements.

VERTICAL FORCES

The soil exerted an average upward force of 100 lb (445 N) on the opener. The force increased to 150 lb (668 N) after the backswept knives were worn. The weight of the cultivator or drill and openers must overcome these upward forces. For comparison, the soil exerted an average downward or suction force of 50 lb (223 N) on a 12 in (305 mm) wide sweep opener.

INSTALLATION

Ease of installing the opener on a shank was fair. Mounting the openers required holding pieces on the front and back of the shank and placing the bolts in position. The bolt spacing was variable from 2 to 2.75 in (51 to 70 mm). Standard 0.5 in (13 mm) hexagon head bolts were used to mount the opener. Bolt lengths of 4.25 and 5 in (108 and 127 mm) were required. Two 0.5 x 2.25 in (13 x 57 mm) plow bolts were used to mount the backswept knife and delivery tube. The seed and fertilizer delivery tube inlets were 1.25 in (32 mm) ID. A vertical tab on the seed delivery tube inlet was used to secure the delivery hose with a hose clamp. No installation or operation instructions were provided.

SPECIFICATIONS

Mounted Dimensions	
-Height	11.8 in (300 mm)
-Width	4.4 in (112 mm)
-Length	17 in (432 mm)
-Depth below shank	3.3 in (84 mm)
Weight	16.3 lb (7.4 kg)

KEY AG VENTURES SEVEN INCH CHROME WITH BACKSWEEP KNIFE

MANUFACTURER:

Key Ag Ventures
 4630 61 Street
 Red Deer, Alberta T4N 2R2
 Phone: (403) 343-6342

RETAIL PRICE: (March, 1995)

\$26.00	7 in (178 mm) Chrome Sweep
23.00	SB1 Seed Boot
11.00	Backswept Knife
9.00	Granular Fertilizer Tube
<u>\$69.00</u>	TOTAL

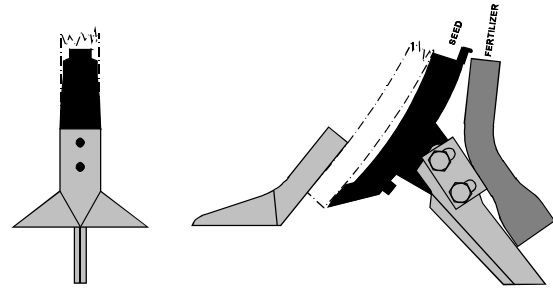

Figure 1. Key Ag Seven Inch Chrome With Backswept Knife.

GENERAL DESCRIPTION

The Key Ag Ventures Seven Inch Chrome with Backswept Knife is a pair row type opener (FIGURE 1). The opener consists of a chrome sweep, air seeder spreader boot with divider, backswept knife and a fertilizer delivery tube. The spreader boot delivers the seed behind the chrome sweep. The chrome sweep mounts to the front of the shank and the spreader boot to the back. The backswept knife bolts to the back of the spreader boot. The length of the backswept knife below the chrome sweep is adjustable. The opener mounts on 50 degree chisel plow shanks.

RESULTS AND DISCUSSION

Seed and Fertilizer Placement: The manufacturer recommended that the backswept knife be mounted in the highest position and lowered as the knife wears off. A narrow divider was used with a seed boot. The average seed and fertilizer placement was as listed in TABLE 1 and shown in FIGURE 2. The seed pattern was more highly concentrated near the outside with occasional seeds in the centre. This was measured as a single row.

Table 1. Seed and Fertilizer Placement.

PLACEMENT	in	mm
Seed Depth Range	0.6	15
Fertilizer Depth Range	0.8	20
Seed Band Width	5.9	150
Fertilizer Band Width	0.8	20
Vertical Separation	2.0	51
Horizontal Separation	0.0	00

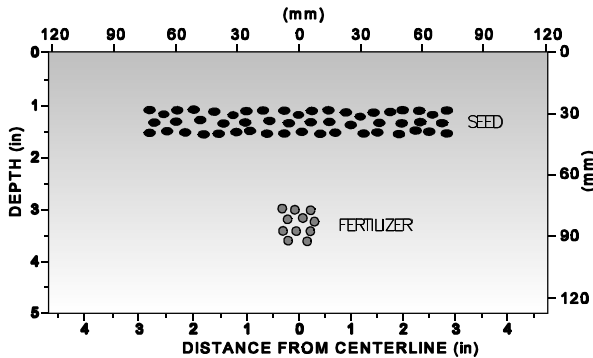

Figure 2. Seed and fertilizer placement.

DRAFT AND POWER REQUIREMENTS

Average draft (drawbar pull) ranged from 350 to 450 lb (1558 to 2003 N) over a 5.5 to 6 in (140 to 152 mm) tillage depth. For comparison, the average draft for a 12 in (305 mm) wide sweep opener ranged from 215 to 280 lb (957 to 1246 N) over a 3 to 3.5 in (76 to 89 mm) tillage depth.

The drawbar power needed to operate each opener at 5 mph (8 km/h) varied from 4.7 to 6 hp (3.5 to 4.5 kW). For comparison, the drawbar power needed to operate a 12 in (305 mm) wide sweep opener varied from 2.9 to 3.7 hp (2.2 to 2.8 kW). Increases in ground speed increased the power requirements.

VERTICAL FORCES

The soil exerted an average upward force of 100 lb (445 N) on the opener. The force increased to 150 lb (668 N) after the backswept knives were worn. The weight of the cultivator or drill and openers must overcome these upward forces. For comparison, the soil exerted an average downward or suction force of 50 lb (223 N) on a 12 in (305 mm) wide sweep opener.

INSTALLATION

Ease of installing the opener on a shank was fair. Mounting the openers required holding pieces on the front and back of the shank and placing the bolts in position. The bolt spacing was variable from 2 to 2.75 in (51 to 70 mm). Standard 0.5 in (13 mm) hexagon head bolts were used to mount the opener. Bolt lengths of 4.25 and 5 in (108 and 127 mm) were required. Two 0.5 x 2.25 in (13 x 57 mm) plow bolts were used to mount the backswept knife and delivery tube. The seed and fertilizer delivery tube inlets were 1.25 in (32 mm) ID. A vertical tab on the seed delivery tube inlet was used to secure the delivery hose with a hose clamp. No installation or operation instructions were provided.

SPECIFICATIONS

Mounted Dimensions	
-Height	11.9 in (302 mm)
-Width	6.9 in (175 mm)
-Length	17.3 in (439 mm)
-Depth below shank	3.3 in (84 mm)
Weight	16.9 lb (7.7 kg)

MORRIS CONVENTIONAL DOUBLE SHOOT OPENER

MANUFACTURER:

Morris Industries Ltd.
85 York Road
Yorkton, Saskatchewan S3N 3P2
Phone: (306) 783-8585

RETAIL PRICE: (March, 1995)

\$40.00 for Morris Conventional Double Shoot Opener.

GENERAL DESCRIPTION

The Morris Conventional double shoot opener is a single row, side band type opener (FIGURE 1). The opener consists of three pieces held together with bolts and a roll pin. The front point creates the furrow for the fertilizer. The replaceable front point is welded to the shank mount. The shank mount fits on the front of the shank. A plate on the left side of the opener creates the furrow for the seed. The plate is secured to the fertilizer delivery tube with a screw and clip. A frame welded to the seed delivery tube fits on the back of the shank. The opener mounts on 47 degree, 0.9 in (23 mm) thick chisel plow shanks.

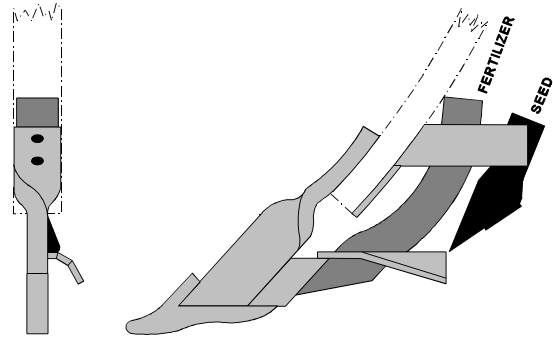

Figure 1. Morris Conventional Double Shoot Opener.

RESULTS AND DISCUSSION

Seed and Fertilizer Placement: The average seed and fertilizer placement was as listed in TABLE 1 and shown in FIGURE 2. Plugging of the fertilizer delivery tubes occurred regularly in wet clay soil conditions.

Table 1. Seed and Fertilizer Placement.

PLACEMENT	in	mm
Seed Depth Range	0.6	15
Fertilizer Depth Range	0.6	15
Seed Band Width	0.8	20
Fertilizer Band Width	0.8	20
Vertical Separation	0.8	20
Horizontal Separation	1.0	25

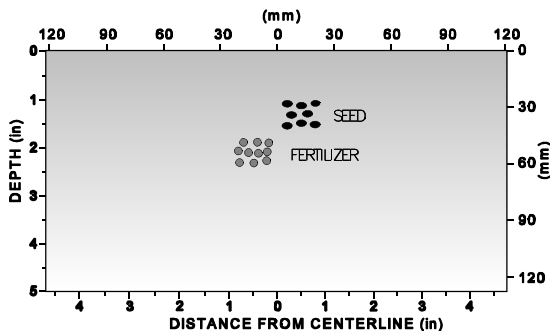

Figure 2. Seed and fertilizer placement.

DRAFT AND POWER REQUIREMENTS

Average draft (drawbar pull) ranged from 120 to 270 lb (534 to 1202 N) over a 3 to 3.5 in (76 to 89 mm) tillage depth. For comparison, the average draft for a 12 in (305 mm) wide sweep opener ranged from 215 to 280 lb (957 to 1246 N) over a 3 to 3.5 in (76 to 89 mm) tillage depth.

The drawbar power needed to operate each opener at 5 mph (8 km/h) varied from 1.6 to 3.6 hp (1.2 to 2.7 kW). For comparison, the drawbar power needed to operate a 12 in (305 mm) wide sweep opener varied from 2.9 to 3.7 hp (2.2 to 2.8 kW). Increases in ground speed increased the power requirements.

VERTICAL AND LATERAL FORCES

The soil exerted an average upward force of 40 lb (178 N) on the opener. The weight of the cultivator or drill and openers must overcome these upward forces. For comparison, the soil exerted an average downward or suction force of 50 lb (223 N) on a 12 in (305 mm) wide sweep opener.

The soil exerted an average lateral force of 30 lb (134 N) on the opener. Skewing was not a problem with the openers during the test.

INSTALLATION

Ease of installing the opener on a shank was fair. Mounting the openers required holding pieces on the front and back of the shank and placing the bolts in position. The bolt spacing varied from 1.4 to 1.6 in (36 to 41 mm). Standard 0.5 x 2.75 in (13 x 70 mm) hexagon head bolts were used to mount the opener. The delivery tube inlets were 1.25 in (32 mm) ID. No installation or operation instructions were provided.

SPECIFICATIONS

Mounted Dimensions

-Height	9.3 in (236 mm)
-Width	2.5 in (64 mm)
-Length	14.4 in (366 mm)
-Depth below shank	4.2 in (107 mm)
Weight	7.4 lb (3.4 kg)

MORRIS EDGE-ON DOUBLE SHOOT OPENER

MANUFACTURER:

Morris Industries Ltd.
85 York Road
Yorkton, Saskatchewan S3N 3P2
Phone: (306) 783-8585

RETAIL PRICE: (March, 1995)

\$62.00 for Morris Edge-on Double Shoot Opener.
\$13.17 for Replacement Point.

GENERAL DESCRIPTION

The Morris Edge-on double shoot opener is a single row, side band type opener (FIGURE 1). The opener consists of four pieces held together with bolts and roll pins. The front point creates the furrow for the fertilizer. The front point is secured to the shank mount with a roll pin. The shank mount is U-shaped and fits on the front of the shank. A plate on the left side of the opener creates the furrow for the seed. The plate is secured to the fertilizer delivery tube with a screw and clip. Metal straps welded to the seed delivery tube fit on each side of the shank mount. Bolts through the shank mount and shank secure the opener. The opener mounts on the Morris Edge-on shank.

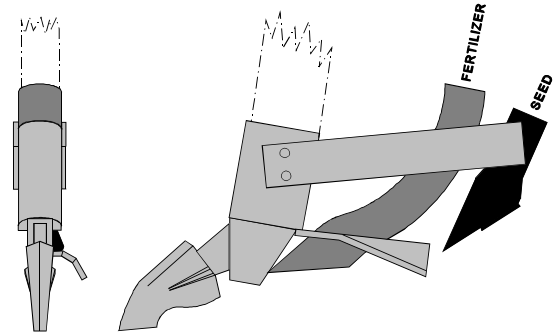

Figure 1. Morris Edge-on Double Shoot Opener.

RESULTS AND DISCUSSION

Seed and Fertilizer Placement: The average seed and fertilizer placement was as listed in TABLE 1 and shown in FIGURE 2. Plugging occurred regularly on half of the fertilizer delivery tubes in wet clay soil conditions.

Table 1. Seed and Fertilizer Placement.

PLACEMENT	in	mm
Seed Depth Range	0.8	20
Fertilizer Depth Range	0.8	20
Seed Band Width	1.2	30
Fertilizer Band Width	1.2	30
Vertical Separation	1.2	30
Horizontal Separation	1.4	36

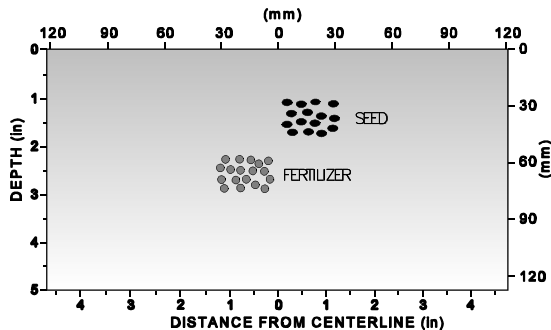

Figure 2. Seed and fertilizer placement.

DRAFT AND POWER REQUIREMENTS

Average draft (drawbar pull) ranged from 200 to 310 lb (890 to 1380 N) over a 4 to 4.5 in (102 to 114 mm) tillage depth. For comparison, the average draft for a 12 in (305 mm) wide sweep opener ranged from 215 to 280 lb (957 to 1246 N) over a 3 to 3.5 in (76 to 89 mm) tillage depth.

The drawbar power needed to operate each opener at 5 mph (8 km/h) varied from 2.7 to 4.1 hp (2 to 3.1 kW). For comparison, the drawbar power needed to operate a 12 in (305 mm) wide sweep opener varied from 2.9 to 3.7 hp (2.2 to 2.8 kW). Increases in ground speed increased the power requirements.

VERTICAL AND LATERAL FORCES

The soil exerted an average upward force of 60 lb (267 N) on the opener. The weight of the cultivator or drill and openers must overcome these upward forces. For comparison, the soil exerted an average downward or suction force of 50 lb (223 N) on a 12 in (305 mm) wide sweep opener.

The soil exerted an average lateral force of 10 lb (45 N) on the opener. Skewing was not a problem with the openers during the test.

INSTALLATION

Ease of installing the opener on the edge-on shank was fair. Mounting the openers required lining up the shank mount and seed boot pieces on the shank and inserting the bolts. Carriage head 3/8 x 2.25 in (0.4 x 57 mm) bolts, spaced 1.3 in (33 mm) apart, were used to mount the opener. The delivery tube inlets were 1.25 in (32 mm) ID. No installation or operation instructions were provided.

SPECIFICATIONS

Mounted Dimensions

-Height	11.3 in (287 mm)
-Width	2.8 in (71 mm)
-Length	14.5 in (368 mm)
-Depth below shank	4.9 in (124 mm)
Weight	10.9 lb (4.9 kg)

NEW NOBLE NUTRIBAND SYSTEM

MANUFACTURER:

New Noble Distributors Inc.
 P.O. Box 359
 Nobleford, Alberta T0L 1S0
 Phone: (403) 824-3711

RETAIL PRICE: (March, 1995)

\$30.00 per shank for New Noble Nutriband System Kit.
 \$9.25 for Front Replacement Point.

GENERAL DESCRIPTION

The New Noble Nutriband system is a single row type opener (FIGURE 1). The system consists of a vertical hoe opener shank with a seed delivery tube bolted to the back. A point is bolted to the front of the shank. The height of the seed delivery tube is adjustable with three different positions. The shank mounts to a standard 4 x 4 in (102 x 102 mm) tube. The system is available as an option on the New Noble 4000 Multi-tool.

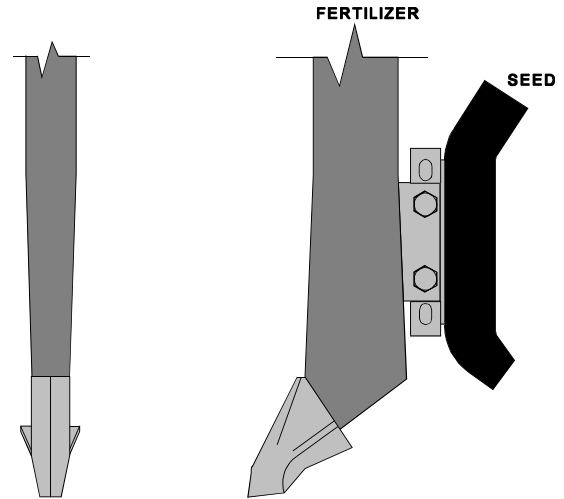

Figure 1. New Noble Nutriband System

RESULTS AND DISCUSSION

NOTE: The following results are based on soil bin results only. The opener was not available for field testing.

Seed and Fertilizer Placement: The average seed and fertilizer placement was as listed in TABLE 1 and shown in FIGURE 2. The system was operated with the rear seed tube in the middle position. Operation with the seed tube in the lower position gave mixing of the seed and fertilizer. Moving the seed tube from the middle to the top position did not change the seed and fertilizer placement. The system is not suitable to use in heavy clay soils.

Table 1. Seed and Fertilizer Placement.

PLACEMENT	in	mm
Seed Depth Range	1.2	30
Fertilizer Depth Range	0.4	10
Seed Band Width	2.0	51
Fertilizer Band Width	0.8	20
Vertical Separation	0.6	15
Horizontal Separation	0.0	00

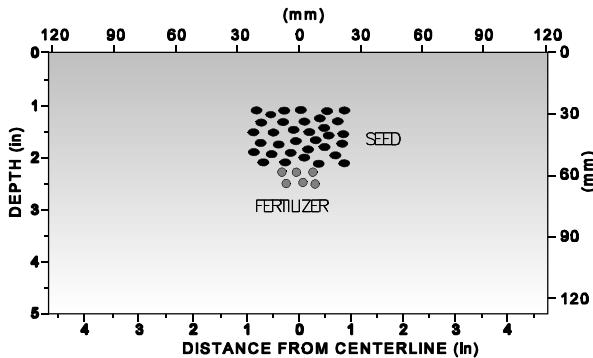

Figure 2. Seed and fertilizer placement.

DRAFT AND POWER REQUIREMENTS

Average draft (drawbar pull) ranged from 140 to 220 lb (623 to 979 N) over a 3 to 3.5 in (76 to 89 mm) tillage depth. For comparison, the average draft for a 12 in (305 mm) wide sweep opener ranged from 215 to 280 lb (957 to 1246 N) over a 3 to 3.5 in (76 to 89 mm) tillage depth.

The drawbar power needed to operate each opener at 5 mph (8 km/h) varied from 1.9 to 2.9 hp (1.4 to 2.2 kW). For comparison, the drawbar power needed to operate a 12 in (305 mm) wide sweep opener varied from 2.9 to 3.7 hp (2.2 to 2.8 kW). Increases in ground speed increased the power requirements.

VERTICAL FORCES

The soil exerted an average upward force of 20 lb (89 N) on the opener. The weight of the cultivator or drill and openers must overcome these upward forces. For comparison, the soil exerted an average downward or suction force of 50 lb (223 N) on a 12 in (305 mm) wide sweep opener.

INSTALLATION

Ease of installing the rear seed tube on the back of the hoe opener shank was good. Standard 3/8 x 0.75 in (10 x 19 mm) or longer hexagon head bolts were used to mount the tube. The seed delivery tube inlet was 1.4 in (36 mm) OD. An operation and adjustment instruction sheet was provided with the openers.

SPECIFICATIONS

Mounted Dimensions (seed delivery tube)	
-Height	9.4 in (239 mm)
-Width	1.8 in (46 mm)
-Length	3.5 in (89 mm)
Weight	2.1 lb (1 kg)

NEW NOBLE SEED-O-VATOR SYSTEM

MANUFACTURER:

New Noble Distributors Inc.
 P.O. Box 359
 Nobleford, Alberta T0L 1S0
 Phone: (403) 824-3711

RETAIL PRICE: (March, 1995)

\$40.78 for New Noble Seed-o-Vator System with 7 in (178 mm) Paired Row Spacing.

GENERAL DESCRIPTION

The New Noble Seed-o-Vator system is a pair row type opener (FIGURE 1). The system consists of a paired row seed boot and a fertilizer tube. The paired row seed boot is Y-shaped and bolts to the back of 50 degree chisel plow shanks. The mounting holes are slotted. The fertilizer tube bolts to the back of the paired row seed boot. The system is used with a chisel plow sweep. The paired row seed boot is available with a 5 or 7 in (127 or 178 mm) paired row spacing. The 7 in (178 mm) paired row spacing was used during the test.

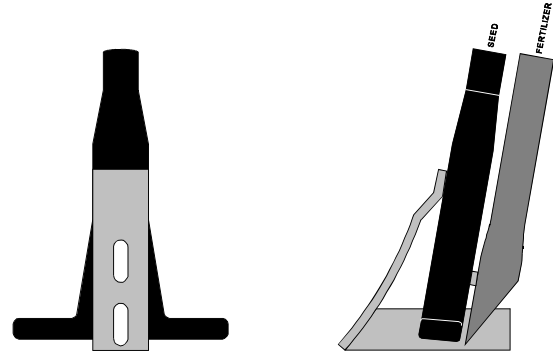

Figure 1. New Noble Seed-o-vator System.

RESULTS AND DISCUSSION

NOTE: The following results are based on soil bin results only. The opener was not available for field testing.

Seed and Fertilizer Placement: The average seed and fertilizer placement was as listed in TABLE 1 and shown in FIGURE 2. The seed boot was mounted midway in the slotted holes.

Table 1. Seed and Fertilizer Placement.

PLACEMENT	in	mm
Seed Depth Range	0.4	10
Fertilizer Depth Range	0.4	10
Seed Band Width	2.4	61
Fertilizer Band Width	3.9	99
Vertical Separation	0.0	00
Horizontal Separation	3.5	89

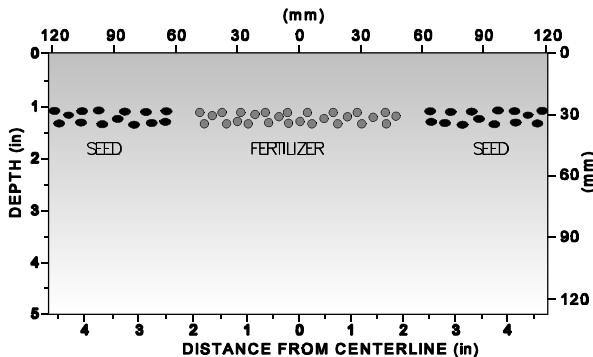

Figure 2. Seed and fertilizer placement.

DRAFT AND POWER REQUIREMENTS

The New Noble Seed-o-vator system is used with a chisel plow sweep so the draft and power requirements are equal to that of a sweep. Average draft (drawbar pull) for a 12 in (305 mm) wide sweep opener ranged from 215 to 280 lb (957 to 1246 N) over a 3 to 3.5 in (76 to 89 mm) tillage depth.

The drawbar power needed to operate each opener at 5 mph (8 km/h) varied from 2.9 to 3.7 hp (2.2 to 2.8 kW). Increases in ground speed increased the power requirements.

VERTICAL FORCES

The soil exerted an average downward or suction force of 50 lb (223 N) on a 12 in (305 mm) wide sweep opener.

INSTALLATION

Ease of installing the rear seed tube on the back of the hoe opener shank was good. The bolt spacing was variable from 1.5 to 3 in (38 to 76 mm). Standard 0.5 x 3 in (13 x 76 mm) or longer hexagon head bolts were used to mount the tube. The seed and fertilizer delivery tube inlets were 1.25 in (32 mm) OD. Operation and adjustment instructions were not provided with the openers.

SPECIFICATIONS

Mounted Dimensions

-Height	10.8 in (274 mm)
-Width	7.9 in (201 mm)
-Length	8.3 in (211 mm)
Weight	6.6 lb (3 kg)

POIRIER DOUBLE SHOOT OPENER

MANUFACTURER:

G and J Poirier Family Farm Ltd.
 P.O. Box 129
 Antler, Saskatchewan S0C 0E0
 Phone: (306) 452-6116

RETAIL PRICE: (March, 1995)

\$170.00 for Poirier Double Shoot Opener (with revised front point).
 \$32.00 for Revised Front Replacement Point (with carbide tip).
 \$28.00 for Rear Backswept Knife (with carbide tip).

GENERAL DESCRIPTION

The Poirier double shoot opener is a single row side band type opener (FIGURE 1). The opener consists of a front point angled back at the top and a backswept knife. The front point creates a furrow for one material and the backswept knife creates a furrow for the other material. Vertical square tubes deliver the material down to the opener and form the frame for the opener. The shank mounting assembly is welded to the back of the vertical tubes. The length of the front point and backswept knife are adjustable. The front point is held in place by a U-shaped clamp. The backswept knife is held in place by a bolt. A carbide tip is attached to the bottom of the front point. The opener mounts on the front of 50 degree chisel plow shanks. The manufacturer has revised the front point for 1995.

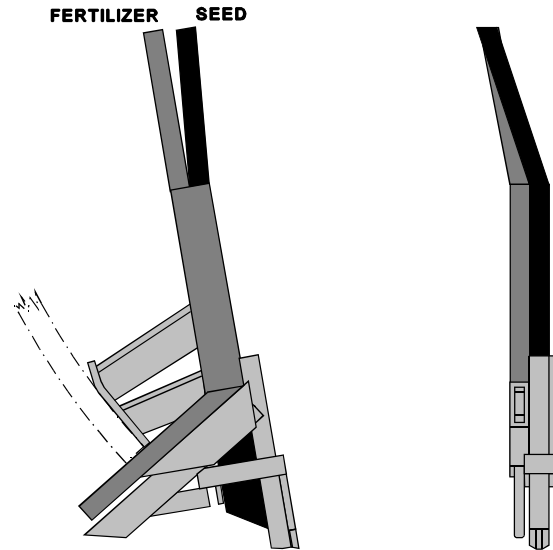

Figure 1 Poirier Opener

RESULTS AND DISCUSSION

Seed and Fertilizer Placement: The opener was operated with the seed placed in the furrow created by the front point and the fertilizer placed in the furrow created by the backswept knife. The manufacturer recommended that the backswept knife be set at the same depth or shallower than the front point. The backswept knife was operated at the same depth as the front point during the test. The average seed and fertilizer placement was as listed in TABLE 1 and shown in FIGURE 2. Two distinct rows were formed.

Table 1. Seed and Fertilizer Placement.

PLACEMENT	in	mm
Seed Depth Range	1.0	25
Fertilizer Depth Range	1.0	25
Seed Band Width	1.0	25
Fertilizer Band Width	0.8	20
Vertical Separation	0.0	00
Horizontal Separation	1.2	30

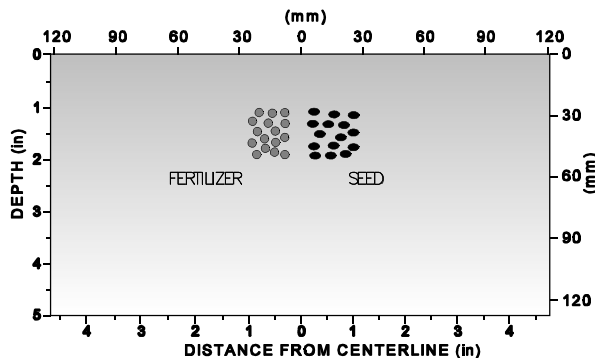

Figure 2. Seed and fertilizer placement.

DRAFT AND POWER REQUIREMENTS

Average draft (drawbar pull) ranged from 165 to 330 lb (734 to 1469 N) over a 2.5 to 3 in (64 to 76 mm) tillage depth. For comparison, the average draft for a 12 in (305 mm) wide sweep

opener ranged from 215 to 280 lb (957 to 1246 N) over a 3 to 3.5 in (76 to 89 mm) tillage depth.

The drawbar power needed to operate each opener at 5 mph (8 km/h) varied from 2.2 to 4.4 hp (1.7 to 3.3 kW). For comparison, the drawbar power needed to operate a 12 in (305 mm) wide sweep opener varied from 2.9 to 3.7 hp (2.2 to 2.8 kW). Increases in ground speed increased the power requirements.

VERTICAL AND LATERAL FORCES

The soil exerted an average upward force of 30 lb (134 N) on the opener. The weight of the cultivator or drill and openers must overcome these upward forces. For comparison, the soil exerted an average downward or suction force of 50 lb (223 N) on a 12 in (305 mm) wide sweep opener.

The soil exerted an average lateral force of 15 lb (67 N) on the opener. The manufacturer supplies left and right openers to counteract the lateral force. Equal number of left and right openers should be used on the cultivator or drill.

INSTALLATION

Ease of installing the one piece opener on a shank was good. The bolt spacing was 2.25 in (57 mm). Standard 0.5 x 3.0 in (13 x 76 mm) or longer hexagon head bolts were used to mount the opener. The delivery tubes were 1 in (25 mm) OD. No written installation or operation instructions were provided.

MECHANICAL HISTORY

A carbide tip from a front point was lost during field operation. The tip was improperly installed during manufacturing.

SPECIFICATIONS

Mounted Dimensions (with front point in top position)

- Height 26.3 in (668 mm)
- Width (not including delivery tube inlets) 2.5 in (64 mm)
- Length 11.3 in (287 mm)
- Depth below shank 5.1 in (130 mm)

Weight 21.9 lb (9.9 kg)

SWEDE DUAL PLACEMENT OPENER

MANUFACTURER:

Swede Industries
 P.O. Box 298
 Tompkins, Saskatchewan S0N 2S0
 Phone: (306) 622-4428

RETAIL PRICE: (September, 1995)

\$34.95 Shank Holder
 15.00 Seed Knife
 30.00 Fertilizer Knife
 \$79.95 TOTAL (plus freight from Regina, SK)

GENERAL DESCRIPTION

The Swede Dual Placement opener is a single row, side band type opener (FIGURE 1). The opener consists of three pieces held together with two bolts. The front point creates a furrow for the seed. A banding point located on the opposite side of the front point creates a furrow for the fertilizer. Delivery tubes are welded to the back of the points. A vertical transition piece fits between the points and connects the opener to the shank. The opener mounts on 50 degree chisel plow shanks. Left and right openers are available. The banding point is located on either side of the opener. The manufacturer advises that brakes be used on the seed and fertilizer delivery tubes to reduce material velocities at the opener.

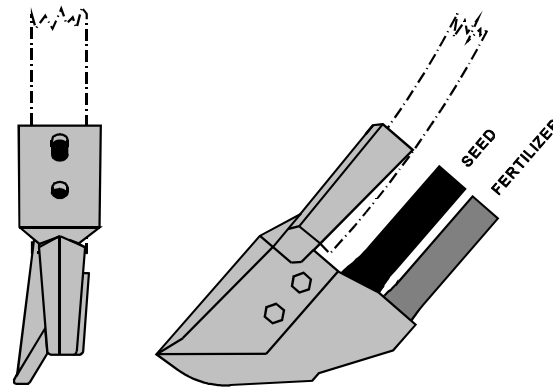

Figure 1. Swede Dual Placement Opener.

RESULTS AND DISCUSSION

Seed and Fertilizer Placement: The average seed and fertilizer placement was as listed in TABLE 1 and shown in FIGURE 2. Brakes were used on the seed and fertilizer delivery tubes. A distinct seed row was formed but some seed was usually placed in the fertilizer furrow. The amount of seed placed in the fertilizer furrow was not consistent. Random field measurements found 0, 4, 9, 15 and 26 percent of the seed in the fertilizer furrow. The most common amount of seed placed in the fertilizer furrow was 15 percent.

Table 1. Seed and Fertilizer Placement.

PLACEMENT	in	mm
Seed Depth Range	0.6	15
Fertilizer Depth Range	0.8	20
Seed Band Width	1.4	36
Fertilizer Band Width	1.0	25
Vertical Separation	0.6	15
Horizontal Separation	1.8	46

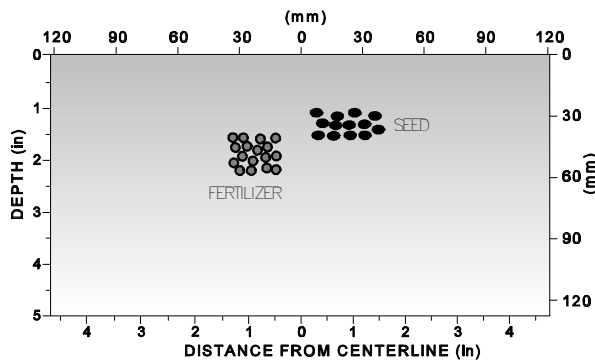

Figure 2. Seed and fertilizer placement.

DRAFT AND POWER REQUIREMENTS

Average draft (drawbar pull) ranged from 170 to 230 lb (757 to 1024 N) over a 3 to 3.5 in (76 to 89 mm) tillage depth. For comparison, the average draft for a 12 in (305 mm) wide sweep opener ranged from 215 to 280 lb (957 to 1246 N) over the same tillage depth.

The drawbar power needed to operate each opener at 5 mph (8 km/h) varied from 2.3 to 3.1 hp (1.7 to 2.3 kW). For comparison, the drawbar power needed to operate a 12 in (305 mm) wide sweep opener varied from 2.9 to 3.7 hp (2.2 to 2.8 kW). Increases in ground speed increased the power requirements.

VERTICAL AND LATERAL FORCES

The soil exerted an average downward or suction force of 40 lb (178 N) on the opener. The flotation of the cultivator or drill must overcome these downward forces. For comparison, the soil exerted an average downward force of 50 lb (223 N) on a 12 in (305 mm) wide sweep opener.

The soil exerted an average lateral force of 30 lb (124 N) on the opener. The manufacturer supplies left and right openers to counteract the lateral force. Equal number of left and right openers should be used on the cultivator or drill.

INSTALLATION

Ease of installing the one piece opener on a shank was good. The bottom bolt hole was slotted. The bolt spacing was variable from 1.5 to 2.5 in (38 to 64 mm). Standard 0.5 x 3 in (13 x 76 mm) hexagon head bolts were required to mount the openers. The delivery tubes were 1.25 in (32 mm) OD. No installation or operation instructions were provided.

SPECIFICATIONS

Mounted Dimensions
 -Height 9 in (229 mm)
 -Width 3.8 in (97 mm)
 -Length 12.4 in (315 mm)
 -Depth below shank 5.4 in (137 mm)
 Weight 15.6 lb (7.1 kg)



3000 College Drive South
Lethbridge, Alberta, Canada T1K 1L6
Telephone: (403) 329-1212
FAX: (403) 328-5562

<http://www.agric.gov.ab.ca/navigation/engineering/afmrc/index.html>

Prairie Agricultural Machinery Institute

Head Office: P.O. Box 1900, Humboldt, Saskatchewan, Canada S0K 2A0
Telephone: (306) 682-2555

Test Stations:

P.O. Box 1060

Portage la Prairie, Manitoba, Canada R1N 3C5

Telephone: (204) 239-5445

Fax: (204) 239-7124

P.O. Box 1150

Humboldt, Saskatchewan, Canada S0K 2A0

Telephone: (306) 682-5033

Fax: (306) 682-5080