

Printed: May, 1983  
Tested at: Lethbridge  
ISSN 0383-3445

# Evaluation Report 301



## Melroe Model 116-78 Sprague

A Co-operative Program Between



ALBERTA  
FARM  
MACHINERY  
RESEARCH  
CENTRE



PRAIRIE AGRICULTURAL MACHINERY INSTITUTE

# MELROE MODEL 116-78 SPRA-COUCPE

## MANUFACTURER & DISTRIBUTOR:

Clark Equipment Company  
Melroe Division  
P.O. Box 1215, 403 Airport Road  
Bismark, North Dakota 58501

## RETAIL PRICE:

\$22,200.00 (May 1983, f.o.b. Lethbridge, Alberta)

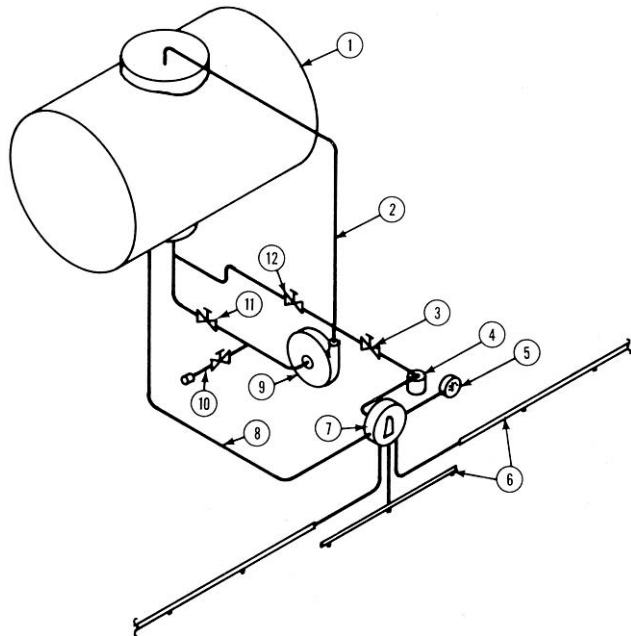

FIGURE 1. System Schematic for Melroe Model 116-78 Spracoupe: (1) Tank, (2) Positive Inlet By-Pass Line, (3) Throttling Valve, (4) Strainer, (5) Pressure Gauge, (6) Booms, (7) Boom Selector Valve, (8) Agitation Hose, (9) Pump, (10) Reload Line and Valve, (11) Inlet Shut-off Valve, (12) Reload Shut-off Valve.

## SUMMARY AND CONCLUSIONS

**Overall Performance:** The performance of the Melroe Model 116-78 Spracoupe was very good. Performance was highlighted by the convenience of placing the booms in transport and field position, adjusting boom height, adjusting nozzle pressure and reloading the spray tank, as well as the quick acceleration, uniform nozzle distribution patterns, stability on hillsides and maneuverability. Improper indication of nozzle pressure and inadequately secured disc brakes were the main problems encountered with the Spracoupe.

**Workrate:** The Spracoupe 116-78 performed well at field speeds up to 14 mph (23 km/h) resulting in an average workrate of 56 ac/hr (22.7 ha/hr). Workrates up to 99 ac/hr (40 ha/hr) were possible in fourth gear under suitable field conditions. The Spracoupe's quick acceleration, handling, stability, and the ease of placing the booms in transport and field position resulted in high workrates, even when reloading from a central location.

**Engine:** The engine had ample power for all field conditions encountered when operated in the first three gears. In fourth gear, inadequate power was available to maintain engine rpm when operating in rolling and hilly fields. Road transport in fourth gear was very good. Maximum transport speed was 22 mph (35 km/h). Fuel consumption averaged about 1.6 gal/hr (7.3 L/hr). Engine oil consumption was insignificant.

**Cab:** The instruments and controls in the cab were handy, conveniently positioned and responsive. The cab air filtering system adequately filtered dust, but not the chemical fumes. Operator station sound level was about 89 dbA. The operators seat was comfortable. Boom visibility from inside the cab was

very good. Rear visibility was slightly restricted by the boom adjusting channel. The liquid level indicator was located inside the cab which made tank liquid level visibility very good.

**Controls:** The Spracoupe was very easy to operate. The throttle, brake and clutch controls were the standard automotive type and very easy to operate and adjust. The brakes responded and performed well. The steering was smooth and responsive, providing very good maneuverability when turning. Flow to the booms was easily controlled by the boom selector valve. Nozzle pressure was easily and quickly adjusted by the in-line throttling ball valve.

**Booms:** The booms were electrically controlled from inside the cab. The electric boom actuators made nozzle height adjusting, placing booms into transport and field position, avoiding field obstacles and boom contact with the ground very convenient. Quick and convenient placement of booms into transport and field position provided for good maneuverability in confined areas. The boom ends had breakaway joints which prevented serious damage to the booms when contact was made with the ground. Nozzle height could be adjusted from 22 to 53 in (560 to 1346 mm).

**Spray Tank:** Utilization of the inboard pump and reload system made spray tank reloading quick and easy. The platform at the spray tank filler opening made adding chemical safe and convenient. The spray tank was easily drained through the reload line. The circular shape of the tank and small sump allowed the operator to completely empty the tank. The spray tank was equipped with a jet agitator. Agitation was more than adequate for applying emulsifiable concentrates and wettable powders.

**Pump:** The Spracoupe was equipped with a Hypro 9202C centrifugal pump and was controlled from inside the cab by an electromagnetic clutch. The pump output was similar to the manufacturer's rated output. Pump output was reduced to 29 gal/min (132 L/min) in the Spracoupe plumbing system.

**Pressure Loss:** Pressure loss from the pump to the nozzle was high. However, sufficient nozzle pressure was still available to apply a maximum of 14.6 gal/ac (162 L/ha) at 14 mph (23 km/h). Pressure loss from the selector valve to the nozzles was around 15 psi (100 kPa), when using the TeeJet 730231 nozzles. Since the pressure was measured at the selector valve, the operator had no indication of nozzle pressure, which is considered essential to ensure proper nozzle spraying patterns and to reduce spray drift. The manufacturer's application chart compensated for the pressure loss to ensure proper application rates. However, the pressures indicated on the charts do not represent nozzle pressure and therefore confuse modern spraying procedure. The pressure gauge was accurate in the normal nozzle spraying range.

**Nozzle Delivery:** The Spracoupe 116-78 was equipped with flat fan TeeJet 730231 brass nozzle tips. A variety of other nozzle tips could be used since the nozzle assembly accepted a wide range of standard nozzle tips. The delivery rate of new 730231 brass nozzles was the same as specified by the nozzle manufacturer. Delivery of the used 730231 nozzles increased about 3% after 51 hours of field use. Variability among individual nozzle deliveries was low when new and used.

**Nozzle Distribution:** Nozzle distribution patterns were very good above 23 psi (159 kPa) with the TeeJet 730231 brass nozzles. Nozzle distribution patterns were very good at nozzle heights above 16 in (406 mm). To minimize and prevent spray drift when using flat fan nozzles it is recommended that the operator avoid nozzle pressures above 45 psi (300 kPa) and operating the boom at heights above 22 in (560 mm), especially in windy conditions.

**Strainers:** The Spracoupe plumbing system was adequately protected with strainers and nozzle plugging was infrequent. The nozzle check valves stayed open occasionally.

**Crop Damage:** Soil pressure beneath the Spracoupe wheels was about the same as that of an unloaded pickup truck and conventional field sprayer wheels. Crops up to 8 in (200 mm)

high could be sprayed with very little crop damage occurring or tire marks visible after a few weeks.

**Safety:** No serious safety hazards were encountered when operating the Spra-Coupe according to the manufacturer's recommended procedures and in accordance with good chemical practice. The Spra-Coupe was equipped with several warning decals to aid the operator. Chemical fumes entered the cab and were irritating to the operator.

**Operator's Manual:** The operator's manual adequately outlined sprayer operation, calibration, servicing, nozzle selection, maintenance and safety tips. No parts list was supplied.

**Mechanical Problems:** Some mechanical problems were encountered during the test. The pump by-pass hose became hot and soft, causing it to rupture under spraying pressure. The bolts securing the disc brakes to the axle assembly loosened frequently. The final drive chain housing leaked throughout the test and the accelerator spring broke twice.

## RECOMMENDATIONS

It is recommended that the manufacturer consider:

1. Modifications so that actual nozzle pressures are measured and shown on the pressure gauge.
2. Modifications to eliminate chemical spilling on the operator's hand when removing the line strainer.
3. Modifications to reduce chemical fumes from entering the operator's cab.
4. Modifications to prevent the by-pass hose from rupturing.
5. Modifications to prevent oil leaking from the final drive housing.
6. Modifications to eliminate disc brake bolt loosening.

Senior Engineer: E. H. Wiens

Project Technologist: L. B. Storzynsky

## THE MANUFACTURER STATES THAT

With regard to recommendation number:

1. Any nozzle body containing a screen and check valve will have some pressure drop during operation; our application chart compensates for this difference. We have been considering and will incorporate a change to measure actual nozzle pressure with any new design on the spray manifold.
2. This change would require major changes in the spray system plumbing but will be considered on any new design or redesign program.
3. We have been monitoring sources of filtration systems and feel that filters now available to the agricultural industry do not completely eliminate the danger of chemical fumes. In fact, many merely eliminate the odor, thereby presenting an even greater danger. We have had very few complaints in this area due to our cab air intake being located on the top front side of the cab.
4. A braid reinforced E.P.D.M. hose has been incorporated on 1983 production models to eliminate this problem.
5. We have eliminated a countersink operation on 1983 production models which improves the surface contact area around the flange mounting bolt.  
Due to the large volume of oil in the chain housing a small amount of leakage between service intervals presents no danger of lack of lubrication.
6. A one piece cast brake disc has been incorporated on 1983 production which will eliminate this problem.

## GENERAL DESCRIPTION

The Melroe Model 116-78 Spra-Coupe is a self-propelled, boom type field sprayer. It is powered by a Volkswagen industrial engine through a four speed synchromesh transmission. Rear wheel final drive is through roller chain and sprockets. The Spra-Coupe is supported on three wheels. The rear wheels provide ground drive and the front wheel is used for steering. It is equipped with a pressurized operator's cab and disc brakes. Conventional automotive controls are used.

The cab is located at the centre of the Spra-Coupe immediately in front of the 172 gal (780 L) plastic spray tank. The tank is equipped with hydraulic agitation and a liquid level indicator. The engine and booms are mounted at the rear. The Spra-Coupe has 31 nozzles spaced at 20 in (508 mm) resulting in a spraying width of 51.7 ft (15.8 m). Nozzles are equipped with check valves to prevent nozzle drip when the boom control is shut off. Boom height is electrically controlled from the operator's station. The electrically controlled booms fold forward for transport. Boom control switches and spray controls are located on the right side of the steering wheel. The centrifugal pump is belt driven from the engine and controlled with an electromagnetic clutch.

FIGURE 1 identifies sprayer and liquid system components while detailed specifications are given in APPENDIX I.

## SCOPE OF TEST

The Melroe Model 116-78 Spra-Coupe was operated for 117 hours in the conditions shown in TABLES 1 and 2 while spraying about 5151 ac (2085 ha). It was evaluated for quality of work, rate of work, pump performance, ease of operation and adjustment, operator safety and suitability of the operator's manual.

During the test, the 73 degree 730231 flat fan Spraying Systems Tee Jet brass nozzle tips supplied with the Spra-Coupe were used for 51 hours. Micromax spinning disc nozzles were mounted and used for the remaining 66 hours of the test.

TABLE 1. Operating Conditions.

| CHEMICAL APPLIED              | FIELD        | HOURS | SPEED<br>mph (km/h) | FIELD AREA<br>ac (ha) |
|-------------------------------|--------------|-------|---------------------|-----------------------|
| (1) Tee Jet 730231<br>Nozzles |              |       |                     |                       |
| Bromox                        | Winter Wheat | 4     | 14 (23)             | 222 (90)              |
| Bromox                        | Winter Wheat | 5.5   | 9 (14.5)            | 174 (70)              |
| 2,4-D Banvel                  | Wheat        | 15    | 22 (35)             | 148 (60)              |
| 2,4-D                         | Wheat        | 35    | 14 (23)             | 1779 (720)            |
| 2,4-D                         | Wheat        | 2     | 22 (35)             | 185 (75)              |
| Hoe Grass                     | Wheat        | 2     | 14 (23)             | 86 (35)               |
| Hoe Grass, Torch              | Wheat        | 1     | 14 (23)             | 49 (20)               |
| (b) Micromax<br>Nozzles       |              |       |                     |                       |
| Wyp-out                       | Wheat        | 19    | 14 (23)             | 680 (275)             |
| Carbyne                       | Wheat        | 6     | 14 (23)             | 185 (75)              |
| 2,4-D                         | Wheat        | 36    | 14 (23)             | 1446 (585)            |
| Hoe Grass                     | Wheat        | 4     | 14 (23)             | 161 (65)              |
| Round-Up                      | Summerfatow  | 1     | 14 (23)             | 37 (15)               |
| TOTAL                         |              | 117   |                     | 5151 (2085)           |

TABLE 2. Field Conditions.

| TOPOGRAPHY | HOURS | FIELD AREA<br>ac (ha) |
|------------|-------|-----------------------|
| Level      | 16    | 617 (250)             |
| Undulating | 42    | 1902 (770)            |
| Rolling    | 49    | 2088 (845)            |
| Hilly      | 10    | 544 (220)             |
| TOTAL      | 117   | 5151 (2085)           |

## RESULTS AND DISCUSSION

### QUALITY OF WORK

**Distribution Patterns:** The TeeJet 730231 brass nozzles were designed for use over a pressure range from 20 to 80 psi (140

to 550) kPa). FIGURES 2 and 3 show spray distribution patterns along the boom with Tee Jet 730231 nozzles when operated at a 20 in (510 mm) nozzle height. The coefficient of variation (CV)<sup>1</sup> at 22 psi (150 kPa) (FIGURE 2) was 16.7%, with application rates along the boom varying from 2.2 to 3.9 gal/ac (24 to 43 L/ha) at 14 mph (23 km/h). High spray concentrations occurred below each nozzle with inadequate coverage between nozzles. At 44 psi (300 kPa) (FIGURE 3) the distribution pattern improved considerably, reducing the CV to 5.9%. Application rate along the boom varied from 3.6 to 4.5 gal/ac (40 to 50 L/ha) at 14 mph (23 km/h). High pressures improved distribution by increasing the overlap and capacity among nozzles. Higher pressure, however, usually causes more spray drift.

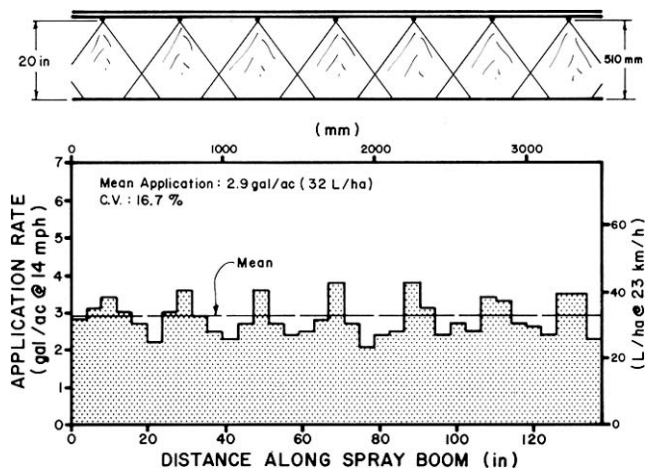

FIGURE 2. Typical Distribution Pattern along the Boom at 22 psi (150 kPa) with Spraying Systems 730231 Brass Nozzles, at a 20 in (510 mm) Nozzle Height.

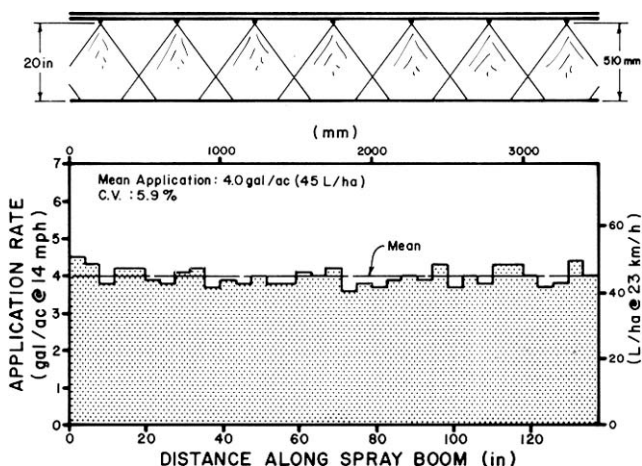

FIGURE 3. Typical Distribution Pattern along the Boom at 44 psi (300 kPa) with Spraying Systems 730231 Brass Nozzles at a 20 in (510 mm) Nozzle Height.

FIGURE 4. shows how nozzle pressure affected pattern uniformity for the TeeJet 730231 flat fan nozzles. The new brass nozzles produced acceptable distribution patterns at pressures above 23 psi (160 kPa) and very uniform patterns at pressures above 28 psi (190 kPa). After 51 hours of field use, there was no significant change in spray pattern uniformity.

More extensive tests are being conducted on the Micromax spinning disc nozzles and their performance will be discussed in a future PAMI report.

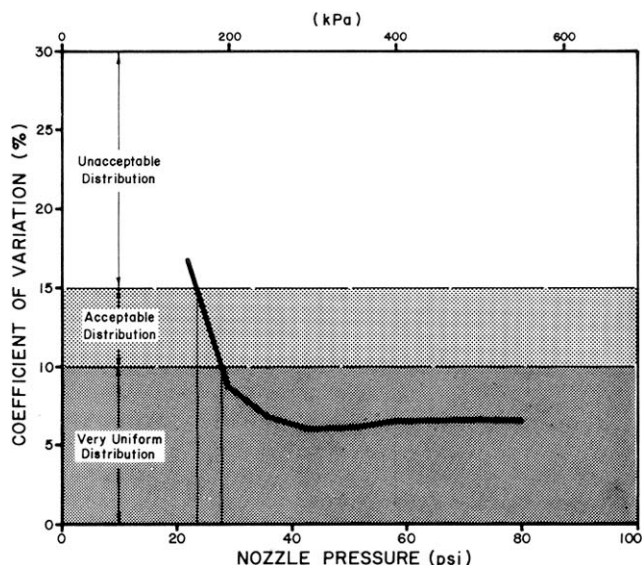

FIGURE 4. Spray Pattern Uniformity for TeeJet 730231 Brass Nozzles Operated at a 20 in (510 mm) Nozzle Height.

**Spray Drift:** Work by the Saskatchewan Research Council<sup>2</sup> indicates that drift is reduced when operating high capacity spray nozzles at low pressures, since fewer small droplets are produced. The TeeJet 730231 nozzles supplied with the Spracoupe are high capacity nozzles and were effective in reducing drift, since they could be operated at low pressures (FIGURE 4), resulting in larger droplet sizes. To minimize drift, the Machinery Institute recommends that with flat fan nozzles, nozzle pressures above 45 psi (300 kPa) not be used.

**Nozzle Calibration:** FIGURE 5 shows the average delivery of Spraying Systems TeeJet 730231 brass nozzles over the recommended operating pressure range. Measured delivery of the new 730231 nozzles agreed with Spraying Systems rated output.

The delivery rate of used 730231 brass nozzles increased about 3% after 51 hours of field use. Some researchers indicate that a nozzle needs replacement once delivery has increased by more than 10%. Nozzle wear depends on the type of chemical sprayed, water cleanliness and nozzle material.

Variability among individual nozzle deliveries for the Tee Jet 730231 nozzles was low. A low CV indicates similar discharge rates for all nozzles while a high CV indicates larger variability among individual nozzle deliveries. The CV of nozzle deliveries was 2.0% when new and decreased to 1.8% after 51 hours of field use.

**Pressure Losses in Plumbing System:** Pressures in the plumbing system were measured at the pump outlet, at the boom selector valve, at the boom inlet and at the nozzle (FIGURE 1). Although pressure loss from the pump to the nozzles was high, pump capacity was adequate to apply up to 14.6 gal/ac (162 L/ha) at 14 mph (23 km/h) and 23.1 gal/ac (257 L/ha) at 9 mph (14.5 km/h). These application rates are sufficient for all common spraying requirements in the prairies.

Pressure loss from the boom selector valve to the nozzles was significant and affected sprayer operation. For example, when using the TeeJet 730231 nozzles, pressure loss from the boom selector valve to the nozzles varied from 10 to 20 psi (69 to 138 kPa), depending on operating pressure. Higher pressure losses occurred when using larger nozzles. Since the pressure gauge measured pressure at the boom selector valve, the operator didn't know what pressure the nozzles were operating at. Knowing actual nozzle pressure is essential to ensure proper nozzle spraying patterns and overlap. Although the

<sup>1</sup>The coefficient of variation (CV) is the standard deviation of application rates for successive 4 in (100 mm) sections along the boom expressed as a per cent of the mean application rate. The lower the CV, the more uniform is the spray coverage. A CV below 10% indicates very uniform coverage while a CV above 15% indicates inadequate uniformity. The CV's above were determined in stationary laboratory tests. In the field, CV's may differ due to boom vibration and wind. Different chemicals vary as to the acceptable range of application rates. For example, 2,4-D solutions have a fairly wide acceptable range while other chemicals may have a narrower range.

<sup>2</sup>Maybank, J.; Yoshida, K.; Shewchuk, S.R., "Comparison of Swath Deposit and Drift Characteristics of Ground-Rig and Aircraft Herbicide Spray Systems" (Report of the 1975 Field Trials, Saskatchewan Research Council Report No. P76-1, January, 1976, p. 16).

manufacturer's application chart compensated for the pressure loss between the boom selector valve and nozzles, the pressure indicated on the chart was misleading. For example, when using the 730231 nozzles with the pressure gauge indicating 35 psi (207 kPa), the actual nozzle spraying pressure was only 20 psi (138 kPa) due to the 15 psi (103 kPa) pressure loss that occurred between the boom selector valve and the nozzles at that application rate. As shown in FIGURE 4, using Tee Jet 730231 nozzles, operating at nozzle pressures below 23 psi (159 kPa) resulted in unacceptable distribution patterns. Therefore, when using 730231 nozzles, boom selector valve pressures below 35 psi (241 kPa) could not be used. Working with pressures other than nozzle pressure confuses modern day spraying practices. Therefore, it is recommended that the manufacturer consider modifications so that actual nozzle pressures are measured and shown on the pressure gauge.

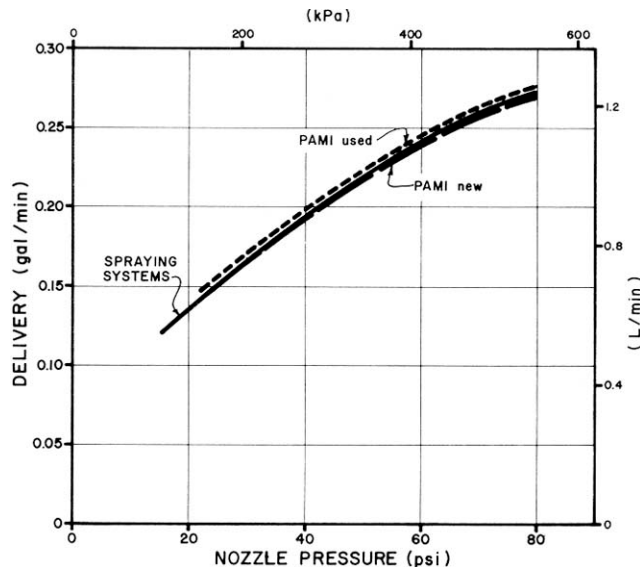

FIGURE 5. Delivery Rates for TeeJet 730231 Brass Nozzles.

**Use of Optional Nozzles:** Even though the nozzle assembly (FIGURE 6) accepted a wide range of standard nozzle tips, only those nozzles indicated on the application chart in the Spra-Coupe operator's manual could be conveniently used. The problem discussed above on the indicated and nozzle pressures being significantly different made the use of other nozzle tips difficult and inconvenient. Leaking occurred between the nozzle body and cap unless securely tightened. Care had to be taken to avoid overtightening and distorting the nozzle body.

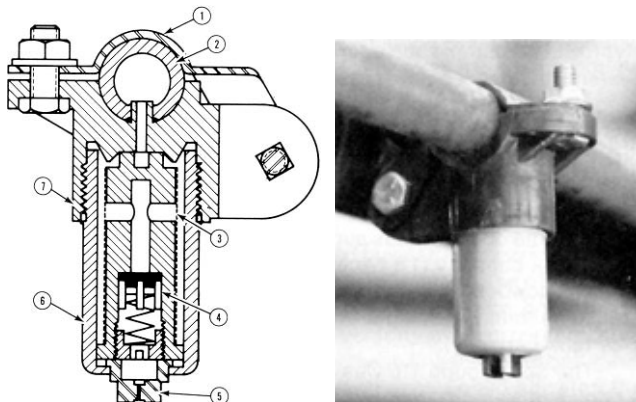

FIGURE 6. Cross Section of Nozzle Assembly: (1) Clamp Top, (2) Spray Boom, (3) Strainer, (4) Check Valve, (5) Nozzle Tip, (6) Nozzle Cap, (7) Nozzle Body.

**Pressure Gauge:** The pressure gauge read 0 to 1.5 psi (0 to 10 kPa) high in the normal operating range throughout the test. This was considered a negligible error.

**Tank Strainer:** No strainer was provided at the tank filler opening since the majority of the refilling was done with the reload system. Foreign particles should be strained from all water entering the sprayer tank.

**Line Strainer:** The 40 mesh strainer located between the pump and control valve effectively removed foreign material. Although the bowl could be easily removed for cleaning, chemical spilled on the operator's hand since the strainer bowl was mounted in a vertical position. It is recommended that modifications be considered to eliminate this problem.

Although no protection was provided for the pump, centrifugal pumps are much less susceptible to damage from foreign material than roller pumps.

**Nozzle Strainers:** The 50 mesh nozzle strainers effectively prevented nozzle plugging. The check valves located in the nozzle strainers (FIGURE 6) usually stopped nozzle drip when the boom control valve was shut-off. Some check valves occasionally stuck open, requiring tapping to seat them.

**Soil Compaction and Crop Damage:** The Spra-Coupe wheels travelled over about 3.8% of the total field area sprayed. The soil contact pressure of only 28 psi (193 kPa) permitted spraying post emergence crops up to 8 in (200 mm) high without any crop damage.

Soil contact pressure beneath the wheels was about the same as an unloaded pickup truck and conventional field sprayer wheels. The average soil contact pressures under the Spra-Coupe wheels with a full tank are given in TABLE 3.

TABLE 3. Soil Compaction by Sprayer Wheels.

|             | AVERAGE SOIL CONTACT PRESSURE* psi (kPa) | TIRE TRACK WIDTH in (mm) |
|-------------|--|--------------------------|
| Front Wheel | 29 (196)                                 | 6.1 (154)                |
| Rear Wheels | 28 (182)                                 | 8.7 (45)                 |

\*For comparative purposes, an unloaded one-half ton truck has a soil contact pressure of about 30 psi (207 kPa).

**Boom Height:** Under normal field conditions the booms remained stable. The wheel and boom suspension also reduced boom movement when operating in rough fields. Operation of the Spra-Coupe on rolling land could result in large variations in boom height. However, as shown in FIGURE 7, a large variation in boom height could occur when equipped with the TeeJet 730231 nozzles, without appreciably reducing spray distribution uniformity. For example, at 45 psi (300 kPa), the 730231 nozzles produced acceptable spray distribution at nozzle heights ranging from 15.8 to 39 in (400 to 1000 mm). However, nozzle heights below 15.8 in (400 mm) could occur when operating the Spra-Coupe on side hills. This could result in reduced uniformity of the distributor pattern due to insufficient overlap of the spray pattern from individual nozzles (FIGURE 8). For example, with the boom located with respect to a side hill as shown in FIGURE 9, the CV was 20.9%. However, since boom height could be adjusted from inside the cab, raising the boom usually improved the spray pattern at both ends of the boom. FIGURE 10 shows how the distribution pattern improved when the boom was raised 8 in (200 mm) from the situation shown in FIGURE 9, reducing the CV from 20.9% to 5.9%. Operating at a boom height above 22 in (560 mm) for an extended period of time is not recommended since spray drift could occur.

#### RATE OF WORK

**Field Speed:** The Spra-Coupe 116 had four forward speeds ranging from 5 to 22 mph (8 to 35 km/h) and one reverse speed. All test work was conducted in gears, 2, 3 and 4, which gave loaded field speeds of 9.0, 14 and 22 mph (14.5, 23 and 35 km/h), respectively. Suitable field speed depended on the nozzles used and field conditions. Most efficient speed in all types of topography encountered during the test (TABLE 2) was 14 mph (23 km/h). Operating in 2nd gear at 9 mph (14.5 km/h), reduced the work rate due to more frequent tank filling. Operating in 4th

gear, at 22 mph (35 km/h), increased the workrate, but the Spra-Coupe had inadequate power to maintain engine rpm and forward speed in all field conditions. This reduced the pump rpm and could result in nozzle pressure decreasing below recommended spraying pressures. Therefore, it was important to select a gear that would allow spraying the entire field at rated engine speed.

When cornering and making sharp turns, engine speed had to be reduced to avoid boom contact with the ground. Spraying during a turn is not recommended due to erratic application rates that result across the boom width due to different ground speeds of the boom. Maximum operating speed was quickly reached after slowing down, thus permitting spraying shortly after a turn.

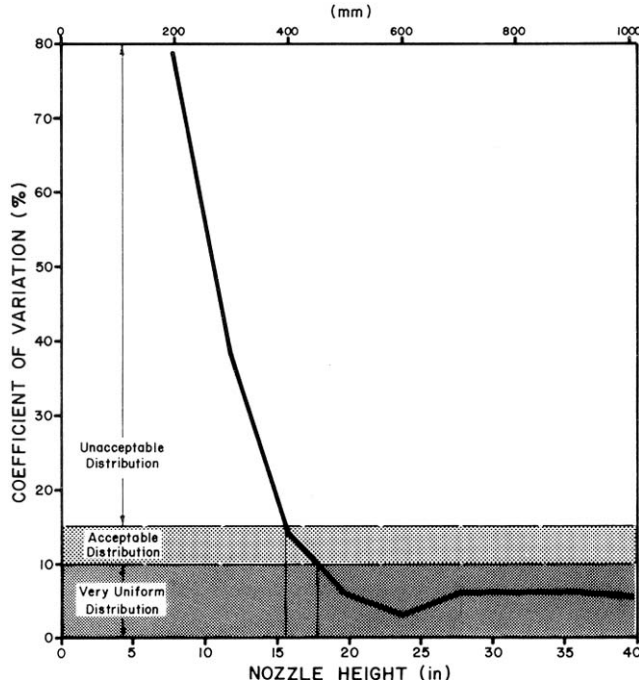

FIGURE 7. Spray Pattern Uniformity at 45 psi (300 kPa) When Operating at Various Boom Heights.

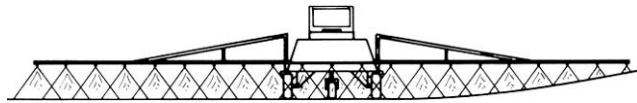

FIGURE 8. Variation of Boom Height on Sidehills.

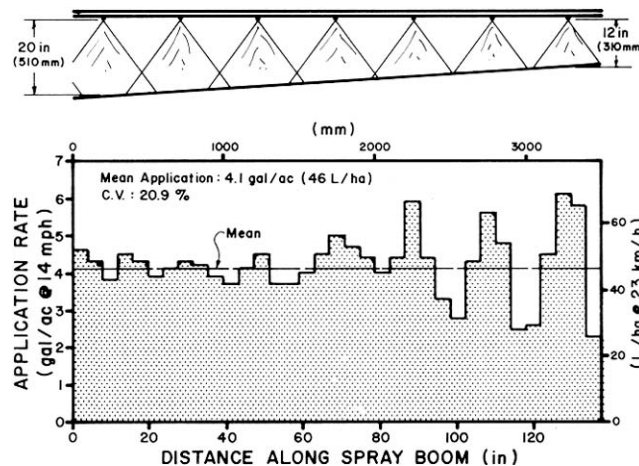

FIGURE 9. Typical Distribution Pattern along the Boom at 45 psi (300 kPa) when Operating on a Sidehill.

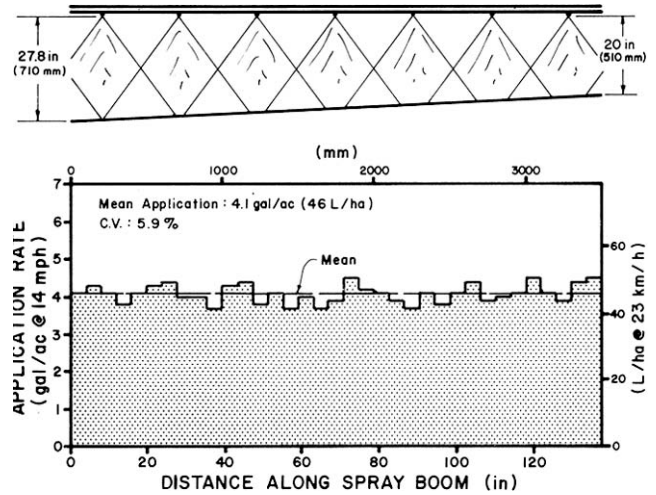

FIGURE 10. Typical Distribution Pattern along the Boom at 45 psi (300 kPa) Operating on a Sidehill, with the Boom Height Raised to Improve Distribution Uniformity.

**Average Workrates:** TABLE 4 shows the average workrates obtained for the Spra-Coupe 116 during the test. Average workrates varied from 31 to 96 ac/hr (13 to 39 ha/hr). Considerable variation can be expected due to field size, shape, topography and gear selection.

TABLE 4. Average Workrates.

| GEAR | SPEED |        | AVERAGE WORKRATE |        |
|------|-------|--------|------------------|--------|
|      | mph   | (km/h) | ac/h             | (ha/h) |
| 2    | 9     | (14.5) | 31               | (13)   |
| 3    | 14    | (23)   | 50               | (20)   |
| 4    | 22    | (35)   | 96               | (39)   |

## PUMP PERFORMANCE

**Priming:** The Hypro 9202C centrifugal pump supplied with the Spra-Coupe was not self-priming. Since the pump was mounted below the spray tank, the positive inlet pressure needed for pump priming was automatically provided. The manufacturer cautioned that the pump not be run dry to avoid damaging the pump seals. The tank provided the pump with liquid in all topographic conditions encountered during the test.

**Output:** FIGURE 11 gives the pump performance curve for the Hypro 9202C centrifugal pump, when disconnected from the Spra-Coupe plumbing system and operated at 6000 rpm. The maximum pump output was 91 gal/min (415 L/min) at a pressure of 177 psi (1220 kPa). Pump output at 6000 rpm was similar to the manufacturer's rated output. Pump wear was negligible after 117 hours of field operation.

FIGURE 11 also shows the pump performance curve for the Hypro 9202C pump when operating in the Spra-Coupe plumbing system at rated engine speed. Even though the rated pump output was 91 gal/min (415 L/min) when removed from the plumbing system, the maximum pump delivery available to the booms was only 29 gal/min (132 L/min) due to inlet plumbing restrictions.

**Agitation:** Normally recommended agitation rates for emulsifiable concentrates such as 2,4-D are 1.5 gal/min per 100 gal of tank capacity (1.5 L/min per 100 L of tank capacity). For wettable powders such as Atrazine, recommended agitation rates are 3.0 gal/min per 100 gal of tank capacity (3.0 L/min per 100 L of tank capacity).

The Spra-Coupe 116 was equipped with a jet agitator with a choice of four different sized, color coded jet nozzles. TABLE 5 shows the Spra-Coupe agitator output during engine idle, road transport and field spraying with the four color coded jet nozzles. During field spraying, the Spra-Coupe agitator output exceeded the required agitation rates for emulsifiable concentrates and wettable powders, regardless of which jet nozzle was used. The throttling valve had to be fully open during engine idling or road transport for maximum agitation to occur.

TABLE 5. Agitator Output.

| JET NOZZLE | ENGINE IDLE     | ROAD TRANSPORT  | FIELD SPRAYING                           |
|------------|-----------------|-----------------|--|
|            | gal/min (L/min) | gal/min (L/min) | AT 43.5 psi (300 kPa)<br>gal/min (L/min) |
| Natural    | 8.1 (36.8)      | 23.8 (108.2)    | 14.7 (66.8)                              |
| Blue       | 7.0 (31.8)      | 23.8 (105.9)    | 13.6 (61.8)                              |
| Red        | 6.4 (29.1)      | 17.8 (80.9)     | 11.9 (54.1)                              |
| Yellow     | 2.9 (13.2)      | 14.1 (64.1)     | 7.7 (35.0)                               |

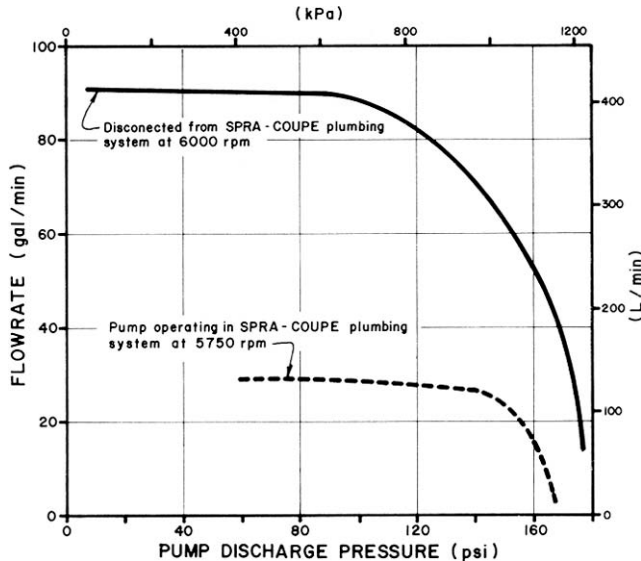

FIGURE 11. Pump Performance Curves.

### EASE OF OPERATION AND ADJUSTMENT

**Operator Location:** The Spra-Coupe 116 was equipped with an operator's cab as standard equipment. The cab was positioned ahead of the spray tank, centered on the applicator body, giving good visibility to the left, front and right. Visibility to the rear was somewhat obstructed by the boom adjusting channel. However, holes in the channel provided adequate rear visibility. The rear view mirror improved rear visibility for road transport. Boom visibility was good in the daytime and poor at night. The spray tank solution level indicator was located inside the cab and could be viewed from the operator's seat.

The operator's seat was comfortable and had an adequate range of front to back adjustment. The seat could not be adjusted vertically. The steering column was not adjustable.

The pressurized cab reduced dust leaks and dust was effectively filtered from the incoming air. Chemical fumes were not effectively filtered, causing operator discomfort. It is recommended that modifications be made to reduce chemical fumes entering the cab. The forced air system provided adequate cooling in all operating conditions encountered during the test.

Operator station sound level was about 89 dbA.

**Controls:** The control arrangement was as shown in FIGURE 12. The controls were conveniently placed, easy to use and responsive. Throttle, brake and clutch controls were the standard automotive type.

Application rate was controlled by gear and nozzle selection and by adjusting nozzle pressure according to the application chart supplied by the manufacturer. Flow to the booms was easily controlled by the boom selector valve. Nozzle pressure was easily and quickly adjusted by the in-line throttling ball valve. The pressure gauge was conveniently positioned allowing the operator to monitor system pressure. However, as already discussed, the indicated pressure was not representative of nozzle pressure.

**Maneuverability:** Steering and maneuverability were very good. Steering of the front wheel was smooth and responsive, while the disc brakes were effective. The turning radius was 20 ft. (6.1 m).

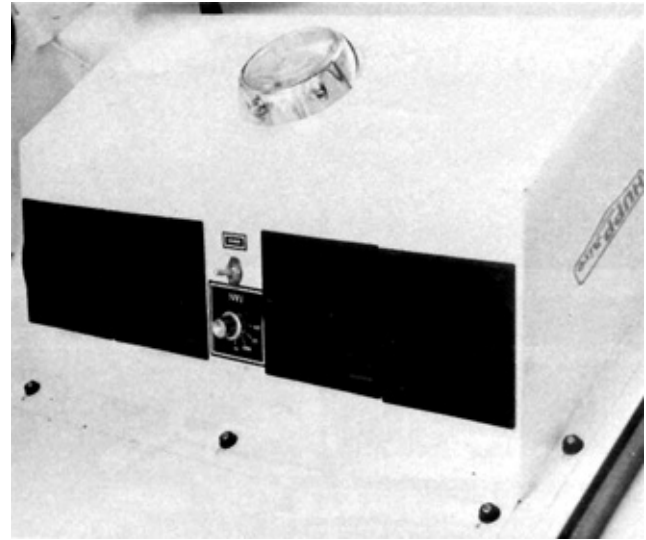

FIGURE 12. Control and Instrument Layout.

**Transmission:** Gear selection depended on the nozzles used and field conditions. The Spra-Coupe 116 allowed the operator a choice of four gears up to 22 mph (35 km/h). One reverse gear was also available. Gear shifting was quick and easy.

**Transport:** The entire boom folded forward electrically from inside the cab for road transport. In this position, the outer booms extended beyond the front of the machine (FIGURE 13). For long transport distances, the outer booms were manually folded and secured with the rubber tie down straps provided (FIGURE 13). Care had to be exercised when folding the booms for transport to ensure the booms were raised high enough to clear the rear wheel fender.

The Spra-Coupe transported well at its maximum speed of 22 mph (35 km/h) both on the road and in the field. The quick folding of the booms and high speed transport made tank refilling from a central location quick and easy.

For transporting at higher speeds and longer distances, a tow hitch was provided. If equipped with the optional floatation tires, the manufacturer recommended replacing them with highway tires and disconnecting the axles if towing at speeds above 22 mph (35 km/h). The axles were easily disconnected.

**Instruments:** The instrument panel (FIGURE 12) included gauges for engine hours, engine speed, control valve pressure and fuel. Warning lights were provided for engine oil pressure, coolant temperature and the electrical system alternator. The air cleaner condition indicator was located inside the engine housing and was easily seen when servicing the engine.



FIGURE 13. Spra-Coupe in Transport Position: (Upper) Partial Transport, (Lower) Complete Transport.

**Lights:** The Spra-Coupe 116 was equipped with two front lights. Front lighting was good. Operating the Spra-Coupe at night was inconvenient since the boom ends were difficult to see. Flood lights were available as optional equipment to illuminate the booms for night spraying.

**Engine:** The engine had ample power for all field and road conditions encountered when operating in the first three gears. Maximum engine speed was attained quickly after turning a corner. The engine speed pulled down and fluctuated when operated in fourth gear in moderately hilly fields. Although the application rate changed very little when engine speeds between 2500 and 3800 rpm occurred, the nozzle pressure decreased below recommended spraying pressures, resulting in inadequate nozzle distribution patterns. Opening the throttling valve to re-establish the proper nozzle pressure resulted in higher application rates than desired. Therefore, it was important to select a gear suitable for the field conditions encountered.

Fuel consumption averaged about 1.6 gal/hr (7.3 L/hr). The engine started easily. Engine oil consumption was insignificant. The fuel tank was located in front of the cab and was easily filled from gravity fuel tanks.

**Stability:** The centre of gravity, with a full spray tank, was about 30 in (762 mm) above the ground, 17.5 in (445 mm) ahead of the drive wheels and 3 in (70 mm) to the left of the Spra-Coupe front tire centre line.

The Spra-Coupe was very stable, even with a full tank.

**Lubrication:** The Spra-Coupe 116-78 had 9 grease fittings. Five grease fittings needed greasing every 10 hours and all were readily accessible. The operator's manual did not indicate lubrication frequency of the other four grease fittings.

Transmission oil level was inconvenient to check and difficult to fill. The rear wheel chain housing was easy to check and fill.

**Reload System:** The reload system (FIGURE 14) was convenient for tank filling from a nurse tank or other water sources. It took about 7 minutes to fill the spray tank.

The supply hose was not provided with the machine, but was available as optional equipment. Care had to be exercised to prevent fluid from the spray tank entering the water supply source when starting and shutting off the reload system. It was, therefore, important to carefully follow the procedure outlined in the operator's manual.

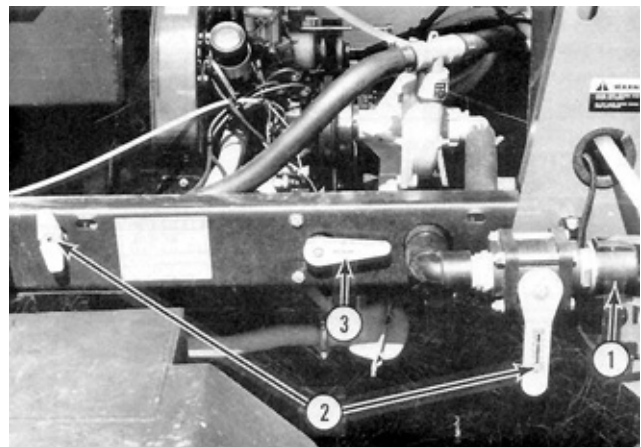

FIGURE 14. Reload System: (1) Reload Outlet, (2) Reload Valves, (3) Suction Valve.

**Spray Tank:** The 172 gal (780 L) spray tank was adequate for the low application rates used. Operating in second gear required more frequent filling. However, due to the convenience of folding the booms, stability and maneuverability of the Spra-Coupe at high transport speeds and due to the convenient reload system, refilling was quick and easy. The filler opening was 67 in (1700 mm) above the ground which made it difficult to fill by gravity from nurse tanks on a farm truck. However, utilization of the reload system made refilling from a nurse truck convenient. Placement of the filler opening near the side of the sprayer tank and a platform near the tank filler opening made adding chemical convenient.

The small sump and circular shape of the tank bottom provided the pump with liquid in all topographic conditions encountered and made tank draining convenient. The tank drain plug was difficult to get at and therefore the reloading valves were used to drain the tank.

**Nozzle Adjustment:** Nozzle angle was easily adjusted without the use of tools by rotating the nozzle assembly (FIGURE 6). Nozzle height could be adjusted electrically from inside the cab over a range from 22 to 46.5 in (560 to 1180 mm) or from 29 to 53 in (737 to 1346 mm), depending on the setting of the boom lift pulley. Adjusting boom height from inside the cab provided for quick and convenient setting of nozzle height. In addition, the booms could be lifted during spraying to avoid field obstacles or adjusted to provide proper nozzle spray overlap when operating on hilly and rolling fields. The lift rate was not always fast enough to prevent the booms from striking or operating too close to the ground in rough and hilly terrain, requiring that operator care be exercised. The breakaway feature of the outer boom ends prevented serious boom damage if the ground or other field objects were hit.

#### OPERATOR SAFETY

The Spra-Coupe 116 had adequate warning decals. It was equipped with warning lights and a rear view mirror for road transport. The operator's manual contained appropriate safety instructions.

**Caution:** Operators are cautioned to wear suitable eye protection, respirators and clothing to minimize operator contact with chemicals. Although many commonly used agricultural chemicals appear to be relatively harmless to humans, they may be deadly. In addition, little is known about the long term effects of human exposure to many commonly used chemicals. In some cases the effects may be cumulative, causing harm after continued exposure over a number of years.

#### OPERATOR'S MANUAL

The operator's manual clearly outlined sprayer operation, maintenance, servicing, calibration, nozzle selection, lubrication and safety tips. No parts list was supplied.



## MECHANICAL PROBLEMS

TABLE 6 outlines the mechanical history of the Spra-Coupe 116 during 117 hours of operation while spraying about 5151 ac (2085 ha). The intent of the test was evaluation of functional performance. An extended durability evaluation was not conducted.

TABLE 6. Mechanical History.

| ITEM   | OPERATING HOURS           | EQUIVALENT FIELD AREA ac (ha) |
|--|---------------------------|-------------------------------|
| Plumbing Assembly  |                           |                               |
| - The nozzle assemblies dripped  | throughout the test       |                               |
| - The pump by-pass hose ruptured at  | 44, 57                    | 1936, 2508 (784, 10, 15)      |
| - The hose was replaced with a reinforced hose at                          | 57                        | 2508 (1015)                   |
| Body   |                           |                               |
| - The cab window sealant deteriorated and leaked                           | throughout the test       |                               |
| - The tank saddle tore away from the frame at the weld and was rewelded at | 57                        | 2508 (1015)                   |
| - The accelator spring broke and was replaced at                           | beginning and end of test |                               |
| Drive  |                           |                               |
| - The rear wheel final drive chain housing leaked                          | throughout the test       |                               |
| - The bolts from both disc brakes loosened and were tightened at           | 57, 115                   | 2508, 5060 (1015, 2049)       |

## DISCUSSION OF MECHANICAL PROBLEMS

**Pump By-Pass Hose:** The pump by-pass hose was situated close to the engine during field operation. The heat from the engine caused the hose to become very soft and rupture. It is recommended that modifications be made to eliminate pump by-pass hose rupturing.

**Final Drive Chain Housing:** The rear wheel final drive chain housing leaked throughout the test in spite of frequent tightening of the bolts and efforts to locate the leak. As a result, the area around the housing became very messy. It is recommended that modifications be made to prevent the housing from leaking.

**Disc Brakes:** The bolts that secure the disc brakes to the axle assembly loosened and came off several times during the test. The loose bolts could not be retightened unless the entire brake assembly was disassembled. This was time consuming and inconvenient. It is recommended that modifications be made to prevent disc brake bolts from loosening.

## APPENDIX I

### SPECIFICATIONS

|                            |   |
|----------------------------|---|
| <b>MAKE:</b>               | Spra-Coupe  |
| <b>MODEL:</b>              | 116-78  |
| <b>SERIAL NUMBER:</b>      |   |
| - body                     | 1164017-82  |
| - engine                   | 089202  |
| <b>MANUFACTURER:</b>       | Clark Equipment Company<br>Melroe Division<br>P.O. Box 1215, 403 Airport Road<br>Bismarck, North Dakota 56501 |
| <b>ENGINE:</b>             |   |
| - make                     | Volkswagen Industrial Engine  |
| - manufacturer             | Volkswagen of America, Inc.<br>Central Zone<br>3737 Lake Cook Road<br>Deerfield, Illinois 60015               |
| - model                    | 126A  |
| - type                     | four stroke, gasoline, air cooled   |
| - number of cylinders      | 4, horizontal position  |
| - displacement             | 96.6 cu in (1583 CC)  |
| - governed speed           | 3800 rpm  |
| - manufacturer's rating    | 53 hp (40 kW) at 3600 rpm   |
| - fuel tank capacity       | 12.5 gal (56 L)   |
| - engine oil capacity      | 2.2 quarts (2.5 L)  |
| - air cleaner              | pre-cleaner and safety indicator  |
| - electrical system        | 12 volt, 46 Ah battery, 51 amp alternator   |
| <b>TRANSMISSION:</b>       |   |
| - type                     | synchro mesh transaxle-4 speeds<br>forward and 1 reverse  |
| - oil capacity             | 4.4 pints (2.5 L)   |
| - final drive              | chain sprockets and roller chain<br>running in oil  |
| - speed - 1st gear         | 5 mph (8 km/h)  |
| - 2nd gear                 | 9 mph (14.5 km/h)   |
| - 3rd gear                 | 14 mph (23 km/h)  |
| - 4th gear                 | 22 mph (35 km/h)  |
| - final drive oil capacity | 5 quarts (5.7 L)  |
| <b>INSTRUMENTS:</b>        |   |
|                            | - engine hourmeter  |
|                            | - fuel tank gauge   |
|                            | - tachometer  |
|                            | - light switch  |
|                            | - ignition switch   |
|                            | - oil temperature warning light   |
|                            | - oil pressure warning light  |
|                            | - alternator indicator light  |
|                            | - 3-boom control switches   |
|                            | - pump activating switch  |
|                            | - pump indicator light  |
|                            | - accelerator lock  |
|                            | - spraying pressure gauge   |
|                            | - choke control   |
|                            | - boom selector valve   |
|                            | - pressure control valve  |
|                            | - fan switch  |
|                            | - wiper switch  |
|                            | - interior light switch   |
| <b>CONTROLS:</b>           |   |
|                            | - clutch pedal  |
|                            | - brake pedal   |
|                            | - accelerator pedal   |
|                            | - gear shift lever  |
|                            | - hand brake  |
|                            | - reload valve  |
|                            | - suction shut-off valve  |
|                            | - reload shut-off valve   |
|                            | - transmission clutch   |
| <b>CLUTCH:</b>             |   |
| <b>AXLE:</b>               |   |
| - rear                     | telescoping to final drive  |
| - front                    | fork spindle  |
| <b>BRAKES:</b>             | automotive type hydraulic disc brakes<br>on rear wheels<br>mechanical linkage to disc pads                    |
| - parking                  |   |
| <b>STEERING:</b>           | standard automotive worm and<br>recirculating ball system   |
| <b>TIRES:</b>              |   |
| - rear                     | floatation, 29 x 12, 15-NH5, 4-ply  |
| - front                    | P225/75R x 15" radial, 4 ply  |
| <b>LUBRICATION POINTS:</b> |   |
| - steering tie rods        | 2, 10 hours   |
| - front wheel fork shaft   | 1, 10 hours   |
| - boom end pivot joints    | 2   |
| - rear wheel pivots        | 2   |
| - telescoping axle shaft   | 2, 10 hours   |

**OVERALL DIMENSIONS:**

|                  |         |             |
|------------------|---------|-------------|
| wheel tread      | 7.1 ft  | (2160 mm)   |
| wheel base       | 9.8 ft  | (3000 mm)   |
| transport height | 7.7 ft  | (2350 mm)   |
| transport length | 16.7 ft | (5100 mm)   |
| transport width  | 8.1 ft  | (2470 mm)   |
| field height     | 7.7 ft  | (2350 mm)   |
| field length     | 16.7 ft | (5100 mm)   |
| field width      | 50.7 ft | (15,460 mm) |
| clearance height | 6.5 in  | (165 mm)    |
| turning radius   |         |             |
| - left           | 19.4 ft | (5900 mm)   |
| - right          | 20.7 ft | (6300 mm)   |

**WEIGHT:****TRANSPORT POSITION**

(No Operator)

|              | Empty             | Loaded            |
|--------------|-------------------|-------------------|
| - front      | 805 lb (365 kg)   | 1113 lb (505 kg)  |
| - left rear  | 1323 lb (600 kg)  | 2028 lb (920 kg)  |
| - right rear | 1279 lb (580 kg)  | 1984 lb (900 kg)  |
| Total        | 3407 lb (1545 kg) | 5125 lb (2325 kg) |

**FIELD POSITION**

(With Operator)

|              | Empty             | Loaded            |
|--------------|-------------------|-------------------|
| - front      | 728 lb (330 kg)   | 1036 lb (470 kg)  |
| - left rear  | 1455 lb (660 kg)  | 2160 lb (980 kg)  |
| - right rear | 1389 lb (630 kg)  | 2094 lb (950 kg)  |
| Total        | 3572 lb (1620 kg) | 5290 lb (2400 kg) |

**SPRAY TANK:**

|             |                            |
|-------------|----------------------------|
| - material  | plastic                    |
| - capacity  | 172 gal (780 L)            |
| - agitation | hydraulic - nozzle jet     |
| - shape     | cylindrical with dome ends |
| - saddle    | sheet metal support        |

**FILLER OPENING:**

|                |                       |
|----------------|-----------------------|
| - shape        | round                 |
| - size         | 8" (203 mm) I.D.      |
| - location     | top, center, left end |
| - type of seal | plastic               |

**STRAINERS:**

|             |             |
|-------------|-------------|
| - main line | 1, 40 mesh  |
| - nozzle    | 31, 50 mesh |

**PUMP:**

|                   |                          |
|-------------------|--------------------------|
| - make            | Hypro                    |
| - model           | 9202 C                   |
| - type            | centrifugal              |
| - operating speed | 5750 rpm (full throttle) |
| - type of drive   | belt                     |

**PRESSURE GAUGES:**

|         |                                     |
|---------|-------------------------------------|
| - make  | Marshall Town                       |
| - type  | bourdon tube                        |
| - range | dual 40 to 1100 kPa<br>5 to 160 psi |

**BOOMS:**

|                            |                                   |
|----------------------------|-----------------------------------|
| - boom inlet hose          | 0.625 in (16 mm) I.D.             |
| - nozzle hose              | 0.530 in (12 mm) I.D.             |
| - material                 | nylon                             |
| - suspension               | clamped to boom tubing            |
| - height adjustment        | 22 to 53 in (559 to 1346 mm)      |
| - angle adjustment         | 90° forward and aft               |
| - effective spraying width | 51.7 ft (15,758 mm)               |
| - nozzle number            | 31                                |
| - pressure regulator       | ball valve on main discharge line |
| - shut-off valve           | selector valve with 8 settings    |

**RELOAD SYSTEM:**

|             |                |
|-------------|----------------|
| - line size | 1.5 in (40 mm) |
| - valve     | ball           |

**APPENDIX II  
MACHINE RATINGS**

The following rating scale is used in PAMI Evaluation Reports:

Excellent  
Very good  
Good  
Fair  
Poor  
Unsatisfactory

**APPENDIX III****CONVERSION TABLE**

|                                      |                          |
|--------------------------------------|--------------------------|
| acres (ac) x 0.40                    | = hectares (ha)          |
| miles/hour (mph) x 1.61              | = kilometres/hour (km/h) |
| inches (in) x 25.4                   | = millimetres (mm)       |
| feet (ft) x 0.305                    | = metres (m)             |
| horsepower (hp) x 0.75               | = kilowatts (kW)         |
| pounds (lb) x 0.45                   | = kilograms (kg)         |
| gallons/acre (gal/ac) x 11.23        | = litres/hectare (L/ha)  |
| pound force/square inch (psi) x 6.89 | = kilopascals (kPa)      |
| gallon (gal) x 4.55                  | = litres (L)             |



**ALBERTA  
FARM  
MACHINERY  
RESEARCH  
CENTRE**

3000 College Drive South  
Lethbridge, Alberta, Canada T1K 1L6  
Telephone: (403) 329-1212  
FAX: (403) 329-5562  
<http://www.agric.gov.ab.ca/navigation/engineering/afmrc/index.html>

**Prairie Agricultural Machinery Institute**

Head Office: P.O. Box 1900, Humboldt, Saskatchewan, Canada S0K 2A0  
Telephone: (306) 682-2555

## Test Stations:

P.O. Box 1060

Portage la Prairie, Manitoba, Canada R1N 3C5

Telephone: (204) 239-5445

Fax: (204) 239-7124

P.O. Box 1150

Humboldt, Saskatchewan, Canada S0K 2A0

Telephone: (306) 682-5033

Fax: (306) 682-5080