

# **Evaluation Report**

# **709**

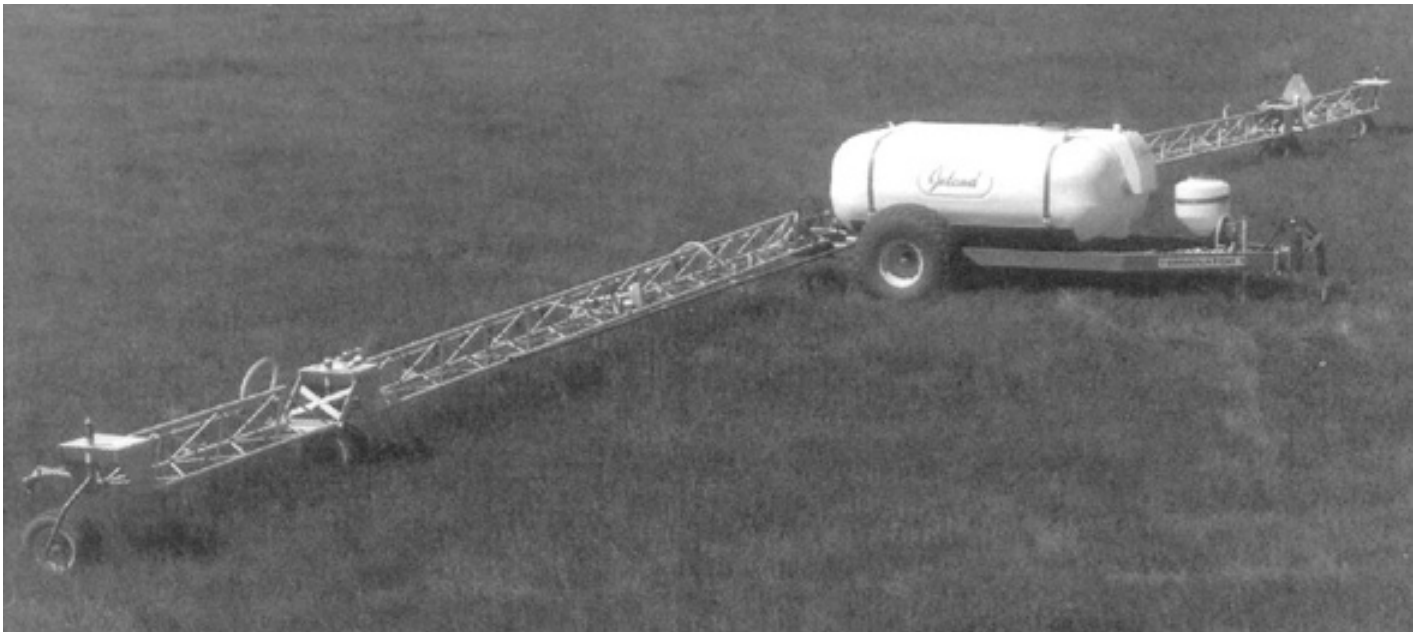

**Inland Model Terminator I Auto-Fold Field Sprayer**

# INLAND MODEL TERMINATOR I AUTO-FOLD FIELD SPRAYER

## MANUFACTURER AND DISTRIBUTOR:

Inland Steel & Forgings Ltd.  
675 Washington Avenue  
Winnipeg, Manitoba  
R2K 1M4  
Phone: (204) 667-7854

## RETAIL PRICE:

\$14,020.00 (June, 1994 f.o.b. Lethbridge, Alberta)

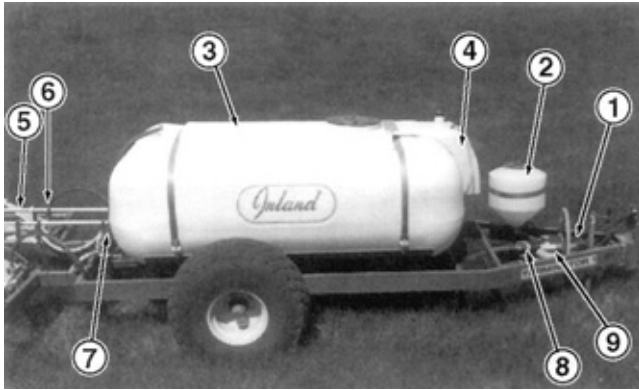

**FIGURE 1.** Inland Model Terminator I Auto-Fold Field Sprayer: (1) Hydraulic Motor and Pump, (2) Easy-Fill Chemical Tank, (3) Spray Tank, (4) Clean Water Tank, (5) Spray Boom, (6) Nozzle Body Assembly, (7) Solenoid and Regulator Valves, (8) Agitator Valve and (9) Strainer.

## SUMMARY AND CONCLUSIONS

### RATE OF WORK

Operating at speeds between 4.3 and 7 mph (6.9 and 11.3 km/h) resulted in instantaneous work rates between 47 and 76 ac/h (19 and 31 ha/h). At an application rate of 10 gal/ac (112 L/ha), 82 ac (34 ha) was sprayed with a full tank.

### QUALITY OF WORK

Application rate accuracy was good when tractor speed and pressure were calibrated for and kept constant. Application rate depended on tractor speed, nozzle size and pressure. The application rate with XR11002VS stainless steel nozzles was 10.2 gal/ac (115 L/ha), at 5 mph (8 km/h) and nozzle pressure of 40 psi (275 kPa).

Measured nozzle delivery rate was good. New TeeJet XR11002VS nozzle deliveries were 2.3 percent higher than specified in the manufacturer's nozzle catalogue. Nozzle wear was rated as good. Delivery rate of used XR11002VS nozzles increased 2.5 percent after 92 hours of use, indicating nozzle wear. Variability amount new or used individual nozzle deliveries was very good. The coefficient of variation (CV) for XR11002VS nozzles was 1.3 percent.

Nozzle spray distribution patterns for Spraying Systems XR11002VS extended range nozzles were very good at nozzle heights above 10 in (250 mm) and nozzle pressures above 20 psi (140 kPa).

In 20 mph (32 km/h) winds, spray drift was fair operating XR11002VS nozzles at the standard 18 in (460 mm) height and 40 psi (275 kPa) pressure. Using extended range XR11002VS nozzles at a nozzle pressure of 20 psi (140 kPa) and at a nozzle height of 12 in (300 mm) reduced spray drift to acceptable levels.

System pressure losses were rated as good. Pressure losses across the boom were less than 1 psi (7 kPa). The pressure sensor indicated 4 psi (25 kPa) low and rated as fair. Calibration of nozzle pressure was required when control console pressure didn't reflect actual nozzle pressure.

Strainers were good in preventing nozzle plugging. Boom stability was good. The tubular truss and suspension system on the boom wheels reduced boom bounce. The extension booms were not as stable and bounced up 2 in (50 mm).

Crop damage was minimal. Trailer and boom wheel soil contact pressure was 25 and 29 psi (175 and 200 kPa), respectively.

## EASE OF OPERATION AND ADJUSTMENT

Ease of adjusting application rate was fair. Spraying Systems single nozzle body assemblies made nozzle changing slow, even though the nozzle caps were easy to remove. Desired application rate was calculated using nozzle formulas and charts. Ease of operating sprayer controls was very good. The customized remote control console made it easy to adjust and monitor nozzle pressure, height and flow from the tractor seat. The console ensured sprayer booms were properly positioned for spraying and transport. Agitator, chemical easy-fill tank and pump shut-off ball valves were accessible and easy to adjust.

Ease of adjusting the middle boom wheels was very good. Adjustments were a trial and error procedure and took a half hour before the booms trailed satisfactorily.

Sprayer maneuverability was very good in both transport and field position. Care was exercised when turning into narrow farmyard approaches since the booms did not follow the sprayer trailer tracks closely. Backing the sprayer in transport position resulted in the booms gradually unfolding.

Ease of boom positioning was very good. The sprayer was placed into transport or field position in one minute. The dial on the control console made the procedure easy to do in the proper sequence. In rough field conditions it took over 100 ft (30 m) for the booms to completely fold for transport.

Ease of adjusting nozzles was good. Nozzle angle was adjusted manually by loosening four U-bolts on the boom parallel linkage. Nozzle height was adjusted with electric linear actuators from 9 to 30 in (230 to 760 mm). The actuators were slow. Booms were also difficult to level.

Ease of filling the spray tank was good. It took about 10 minutes to fill the 820 gal (3730 L) spray tank using a transfer pump and 2 in (50 mm) hose. A bottom reloading system was available as an option.

Ease of adding chemical to the spray tank was good using the easy-fill chemical tank. It took less than a minute to induct chemical from a full easy-fill tank. The pump was operated slowly to prevent pump cavitation.

Ease of hitching was very good. A joint coupler automatically locked to a 2.3 in (60 mm) ball. The coupler was adjustable for levelling the sprayer trailer to the tractor hitch. Four hydraulic lines and an electronic coupler were easy to hook-up.

Ease of cleaning was good. Removing the nozzle caps for nozzle and strainer cleaning was quick, however, the strainers were difficult to remove.

Ease of draining was very good. The pump suction hose was equipped with a quick coupler for draining. The sloped tank bottom allowed for complete draining. Spraying Systems diaphragm nozzle assemblies were difficult to drain.

Ease of lubrication was good. Eighteen grease fittings were accessible. The wing lock pivot grease fittings were difficult to access.

## PUMP PERFORMANCE

The Ace FMC Hyd 210 pump output was good. The pump delivered 13 gal/min (60 L/min) at a 40 psi (275 kPa) nozzle pressure. This was adequate to apply 15 gal/ac (165 L/ha) at a forward speed of 5 mph (8 km/h), using nozzles rated at 0.25 gal/min (1.1 L/min).

Agitator output was very good and exceeded recommended agitation rates for emulsifiable concentrates.

## OPERATOR SAFETY

The operator's manual emphasized operator safety. The sprayer was safe to operate if normal safety and chemical precautions were taken. The easy-fill chemical tank reduced operator contact with chemical.

### OPERATOR'S MANUAL

The operator's manual was very good, providing complete information and illustrations on safety, sprayer operation, maintenance and adjustments.

### MECHANICAL HISTORY

The sleeve connecting the main and extension wet boom carriers failed.

### RECOMMENDATIONS

The AFMRC recommends the manufacturer:

1. Modify the wet boom carrier to prevent the extension booms from dropping.

*Project Technologist: B.L. Storozynsky  
Manager: R.P. Atkins, P.Eng.*

### MANUFACTURER'S REPLIES TO RECOMMENDATIONS

The manufacturer states that with regards to recommendation number,

1. The material for the connecting sleeve has been increased from 14 gauge to 12 gauge to avoid failure.

Additional manufacturer's replies:

1. In order to prevent the extension boom carders from failing, a 3/4" square tube has been installed inside the outer wet boom cader on the 70 ft Terminator to stabilize the boom.
2. Tightening bolts have been changed from grade 2 to grade 5 to avoid breakage. We are in the process of testing a torsion spring mounted on the extension wet boom to counteract excessive torque.

### GENERAL DESCRIPTION

The Inland Model Terminator I is a trailing, boom-type field sprayer. The trailer is mounted on a single axle with flotation turf tires. Two castor wheels with a suspension system support each boom. The booms automatically fold back for transport. The 820 gal (3730 L) plastic tank has four jet agitators, fluid level indicator, a filler opening with strainer and a clean water tank attached on the front.

The Inland sprayer has 54 split-eyelet quick TeeJet nozzle assemblies with diaphragm check valves spaced at 20 in (508 mm) intervals, giving a spraying width of 90 ft (27.4 m). Nozzle height is electrically controlled. Nozzle angle is adjustable and remains constant throughout the height range.

The inland Terminator I has a easy-fill chemical tank, spray tank access platform and remote control console. The pump is hydraulically driven and operates between 3000 and 4600 rpm. The remote control console mounts on the tractor and operates the pressure regulator, boom shut-off valves, nozzle height actuators and boom folding system. The console LCD bar graph indicates nozzle pressure and height.

FIGURE 1, shows the location of the sprayer's major components while detailed specification are given in APPENDIX I.

### SCOPE OF TEST

The Inland Terminator I sprayer was operated for 105 hours in the conditions shown in TABLES 1 and 2 while spraying about 3397 ac (1375 ha). The AFMRC evaluated the sprayer for rate of work, quality of work, ease of operation and adjustment, pump performance, operator safety and suitability of the operator's manual.

Spraying Systems extended range TeeJet XR11002VS stainless steel nozzle tips were used during the test. The nozzle tips were tested in the laboratory at various spraying pressures and heights.

The machine evaluated by the Alberta Farm Machinery Research Centre (AFMRC) was configured as described in the General Description, FIGURE 1 and the Specifications section of this report. The manufacturer may have built different configurations of this machine before or after AFMRC tests. Therefore, when using this report, be sure to first check that the machine you are considering is the same as the one shown here. If not, assistance can be obtained from the manufacturer or AFMRC in determining how this new machine will perform compared to the one tested.

TABLE 1. Operating Conditions

CHEMICAL APPLIED	FIELD	HOURS	SPEED		FIELD AREA	
			mph	km/h	ac	ha
Buctril M	Barley/Spring Wheat	10	5.8-7.0	9.3-11.3	346	140
Buctril M/Avenge	Barley	2	5.0	8.0	65	26
Buctril M/MCPA	Barley	5	7.01	1.3	90	37
2,4-D	Barley/Spring Wheat/Durum	19	5.0-7.0	8.0-11.3	700	283
2,4-D/Assert	Barley/Spring Wheat	6	5.0-5.8	8.0-9.3	195	79
2,4-D/Banvel	Barley/Spring Wheat/Durum	49	4.3-7.0	6.9-11.3	1963	795
Poast/Merge	Canola	1	5.0	8.3	38	15
Transport		13				
TOTALS		105			3397	1375

TABLE 2. Topography

TOPOGRAPHY	HOURS	FIELD AREA	
		ac	ha
Level	45	1621	656
Undulating	37	1399	566
Rolling	10	377	153
Road	13		
TOTAL	105	3397	1375

## RESULTS AND DISCUSSION

### RATE OF WORK

The Inland Terminator I sprayer was operated between 4.3 and 7.0 mph (6.9 and 11.3 km/h) (TABLE 1) resulting in instantaneous work rates between 47 and 76 ac/h (19 and 31 ha/h). Actual work rates were less depending on operator skill and reloading time. The quick folding booms and automatic re-positioning of nozzle pressure and height reduced down time. Spraying at 10 gal/ac (112 L/ha) a full spray tank covered 82 ac (33 ha).

### QUALITY OF WORK

**Application Rate:** Application rate accuracy was good when tractor speed and pressure were calibrated and consistent. The XR11002VS nozzles delivered 10.2 gal/ac (115 L/ha) at 5 mph (8 km/h) and 40 psi (276 kPa) nozzle pressure. FIGURE 2 shows variation in speed or nozzle pressure resulted in different application rates. At 7 mph (11.3 km/h) and 40 psi (275 kPa) nozzle pressure the XR11002VS nozzles delivered 7.2 gal/ac (81.4 L/ha). At a nozzle pressure of 20 psi (140 kPa) and a speed of 7 mph (11.3 km/h) application rate was 5.2 gal/ac (58 L/ha). The XR11002VS nozzles were operated at low pressures in windy conditions. To ensure uniform application rates the desired speed and pressure were kept constant.

**Nozzle Calibration:** Measured nozzle delivery was very good. FIGURE 3 shows the average delivery of Spraying Systems extended range Tee Jet XR11002VS nozzle tips over a range of nozzle pressures. Measured delivery of XR11002VS nozzles averaged 2.3 percent more than Spraying Systems rated output.

Nozzle wear was rated as good. Nozzle wear depends on the type of chemicals sprayed and water cleanliness. The XR11002VS nozzle tips were used for 92 hours. After 92 hours, delivery increased 2.5 percent, indicating some nozzle wear. Some researchers indicate that a nozzle needs replacement once delivery has increased by more than 10 percent.

Variability among individual nozzle deliveries for the Tee Jet XR11002VS nozzles was very good. The coefficient of variation (CV) of new or used nozzle deliveries was 1.3 percent. A low CV indicates similar delivery rates for all nozzles. A high CV indicates large variations among individual nozzle delivery rates.

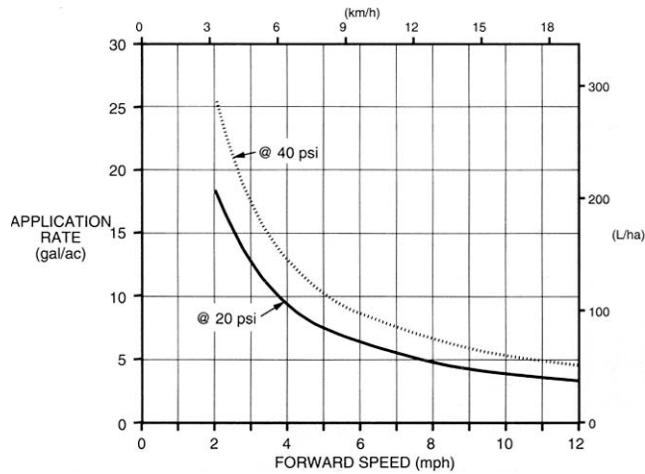

FIGURE 2. Application rates at various speeds and pressures using Spraying Systems extended range Tee Jet XR11002VS nozzles.

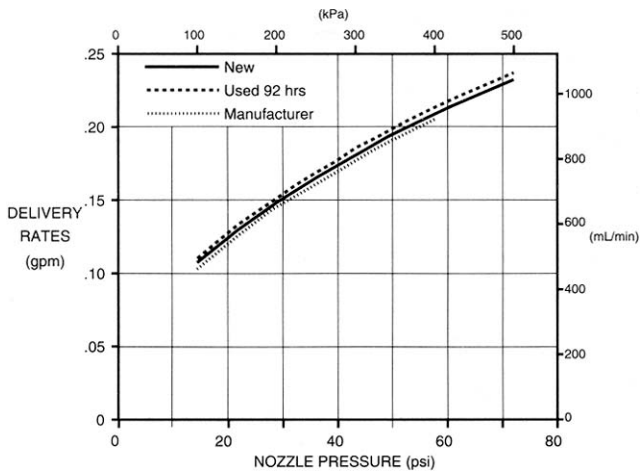

FIGURE 3. Delivery rates for Spraying Systems extended range Tee Jet XR11002VS stainless steel nozzle tips.

**Distribution Patterns:** Nozzle spray distribution patterns for Tee Jet XR11002VS nozzles were very good. The XR11002VS nozzles were tested over a range of pressures and heights. FIGURE 4 shows a spray distribution pattern along the boom at a nozzle pressure of 44 psi (300 kPa) and a nozzle height of 12 in (300 mm). The distribution pattern coefficient of variation (CV)<sup>1</sup> at 44 psi (300 kPa) was 7.8 percent. Application rates along the boom varied from 6.2 to 9.3 gal/ac (70 to 105 L/ha) at 7 mph (11 km/h). Average application rate was 7.5 gal/ac (85 L/ha).

Spray distribution patterns changed very little after the XR11002VS nozzles were used in the field for 92 hours.

Spraying Systems extended range (XR) nozzles were designed to spray at pressures between 15 and 60 psi (100 and 415 kPa). FIGURE 5 shows how nozzle pressure affected XR11002VS spray pattern uniformity. Spray pattern uniformity was better than other extended range nozzles tested in the past. FIGURE 5 also shows spray pattern uniformity for other commonly used flat fan nozzles.

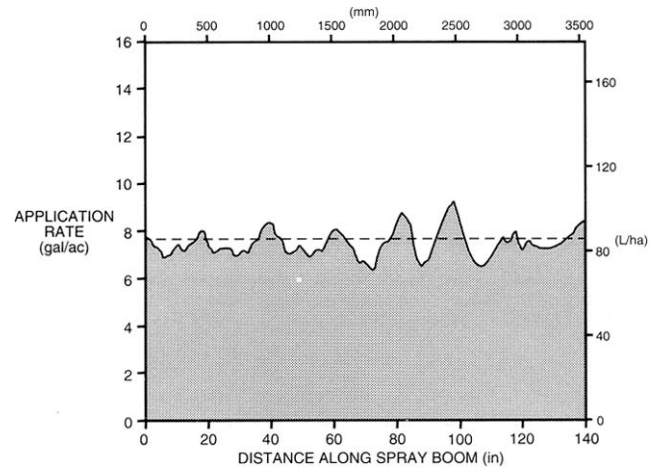

FIGURE 4. Distribution pattern along the boom at 44 psi (300 kPa) with Spraying Systems extended range Tee Jet XR11002VS stainless steel nozzle tips, at a 12 in (300 mm) nozzle height and 7 mph (11 km/h).

These include extended range 80 and 110 degree nozzles, standard 80 and 110 degree nozzles and low drift 110 degree nozzles.

Extended range 110 degree nozzles produced acceptable patterns above 15 psi (100 kPa). The other flat fan nozzles produced acceptable spray patterns above 35 psi (250 kPa).

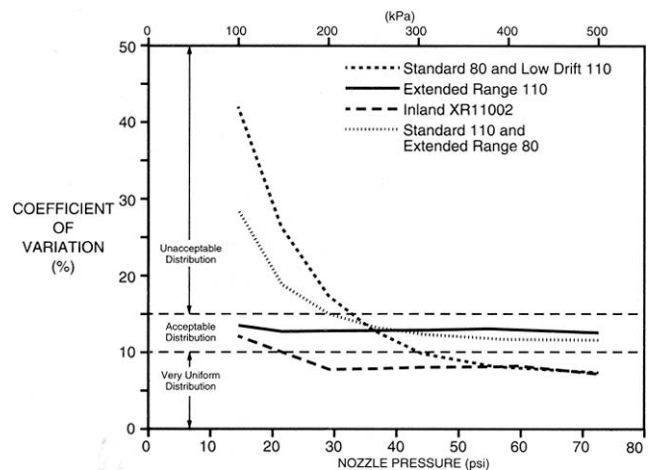

FIGURE 5. Spray pattern uniformity for flat fan extended range, standard and low drift stainless steel nozzles.

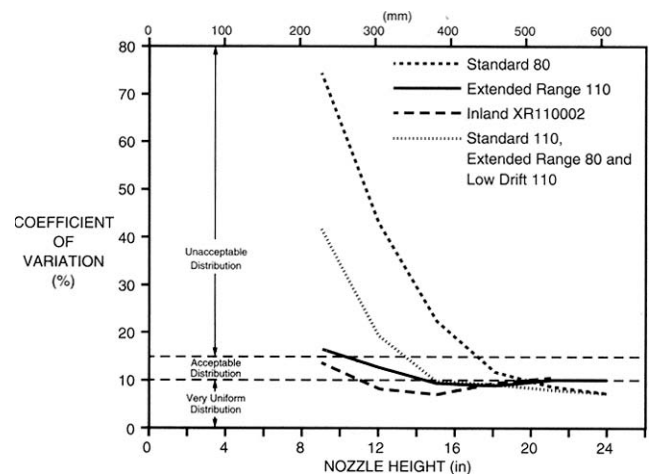

FIGURE 6. Spray pattern uniformity for flat fan extended, standard and low drift flat fan stainless steel nozzles.

<sup>1</sup>The coefficient of variation (CV) is the standard deviation of application rates for successive 0.63 in (16 mm) sections along the boom expressed as a per cent of the mean application rate. The lower the CV, the more uniform is the spray coverage. A CV below 10 per cent indicates very uniform coverage while a CV above 15 percent indicates inadequate uniformity. The CV's above were determined in stationary laboratory tests. In the field, CV's may differ due to boom vibration and wind. Different chemicals vary as to the acceptable range of application rates. For example, 2,4-D solutions have a fairly wide acceptable range while other chemicals may have a narrow range.

FIGURE 6 shows how nozzle height affected spray pattern uniformity for the XR11002VS nozzles and other flat fan nozzles. Spray pattern uniformity for the XR11002VS nozzles was similar to

other extended range 110 degree nozzles tested in the past. Extended range 110 degree nozzles produced acceptable spray patterns as low as 9 in (230 mm) above the target. Standard 110 and extended 80 degree nozzles produced acceptable spray patterns above 15 in (380 mm). The commonly used standard 80 degree nozzles produced acceptable spray patterns above 18 in (460 mm). All nozzles produced acceptable patterns above 18 in (460 mm). Operating nozzles above 18 in (460 mm) were avoided to reduce spray drift, especially in windy conditions.

FIGURES 5 and 6 show the average CV from six size classes of each nozzle type. The sizes include 01, 015, 02, 03, 04 and 06. Usually, smaller sized nozzles have higher CV's than indicated by the average. Larger sized nozzles have lower CV's.

Spray patterns are significantly more uniform with extended range nozzles, because their fan angles are fully developed at 15 psi (100 kPa). For more information on spray pattern uniformity for each type and size of nozzle, contact AFMRC.

**Spray Drift:** Spray drift for Tee Jet XR11002VS flat fan nozzles was fair. Tests were conducted in AFMRC's wind tunnel at a speed of 20 mph (32 km/h). The boom was static and perpendicular to the wind. FIGURE 7 shows relative airborne spray drift for Tee Jet XR11002VS and 8002VS flat fan nozzles. At 40 psi (275 kPa) and 18 in (460 mm), spray drift from XR11002VS nozzles was three times higher than standard 8002VS nozzles. Excessive drift could result in damage to nearby shelter belts, gardens and other susceptible crops.

Studies show 110 degree and extended range nozzles produce a higher percentage of droplets less than 150 microns than 80 degree nozzles of the same size. Spray droplets less than 150 microns are more susceptible to drift. A lower percentage of susceptible droplets were produced operating the XR11002VS nozzles at 20 psi (140 kPa). Operating the XR11002VS nozzles at 20 psi (140 kPa) and 12 in (305 mm) reduced spray drift to acceptable levels. As shown in FIGURES 5 and 6, XR11002VS nozzles were operated at low nozzle pressures and heights without adverse effects on spray patterns.

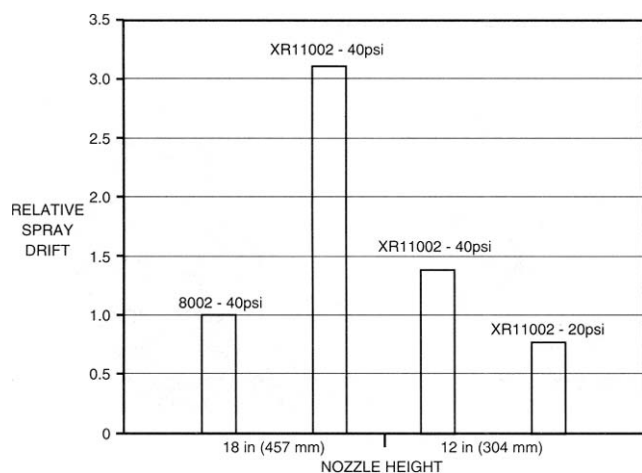

FIGURE 7. Relative airborne spray drift from Tee Jet flat fan nozzles operated in 20 mph (32 km/h) wind speeds.

**Pressure Losses:** Sprayer plumbing pressure losses were rated as good. Pressure losses across the boom were less than 1 psi (7 kPa). Remote console pressure sensor was fair. The sensor was 4 psi (25 kPa) low.

Pressures in the plumbing system were measured at the pump, controls, booms and varying sized nozzles. High pressure loss from pump to boom inlet limited sprayer capacity. Largest nozzles that could be used were rated at 0.25 gal/min (1.1 L/min) (ie. 8003, 11003 nozzles). This was adequate for prairie application rates.

The pressure sensor indicated nozzle pressure, even though pressure was sensed at the boom inlet line. Pressure difference between boom inlet line and nozzles was high. However, the difference did not affect spraying accuracy when nozzle and pressure sensor calibration procedures were correctly followed. Calibrations were necessary when the console pressure bar graph did not reflect actual nozzle pressure. This occurred with different sized nozzles.

**Use of Optional Nozzles:** Spraying Systems nozzle body assembly (FIGURE 8) accepted most flat fan nozzle tips. Some European flat fan nozzle tips did not fit on Spraying Systems nozzle body assemblies. Nozzle height and angle were adjustable permitting the use of flood and cone nozzle tips.

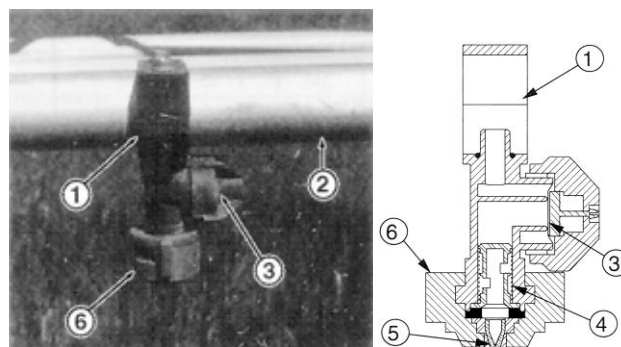

FIGURE 8. Spraying Systems Diaphragm and Nozzle Body Assembly: (1) Split-Eyelet Clamp, (2) Spray Boom, (3) Diaphragm Check Valve, (4) Strainer, (5) Nozzle Tip and (6) Quick-Disconnect and Self-Aligning Nozzle Cap.

**System Strainers:** Inland sprayer system strainers were good. The tank filler opening and pump inlet hose were equipped with 16 and 50 mesh strainers, respectively. Both strainers effectively removed large foreign material. The 50 mesh nozzle strainers effectively prevented the TeeJet XR11002VS nozzles from plugging.

**Boom Stability:** Inland sprayer boom stability was good. The booms remained stable in the field conditions encountered (TABLE 2). The tubular truss system used for boom rail construction and suspension system on the boom wheels reduced boom bounce in rough fields. In addition, the tubular truss reduced horizontal boom movement.

The wet boom carrier system was loose causing the wet booms to bounce in all field conditions encountered. The universal joint (FIGURE 9) connecting the extension wet boom carrier to the main wet boom carrier was loose. This caused the extension boom to move 2 in (50 mm).

The extension boom placed excessive torque on the main wet boom carrier. This caused the extension wet boom to be unstable. In addition, excessive torque caused the sleeve (FIGURE 9) connecting the extension wet boom carrier to the main wet boom carrier to fail.

In transport position, the end castor wheels wobbled. Adjusting the tension on the castor wheel axle did not reduce wobbling.

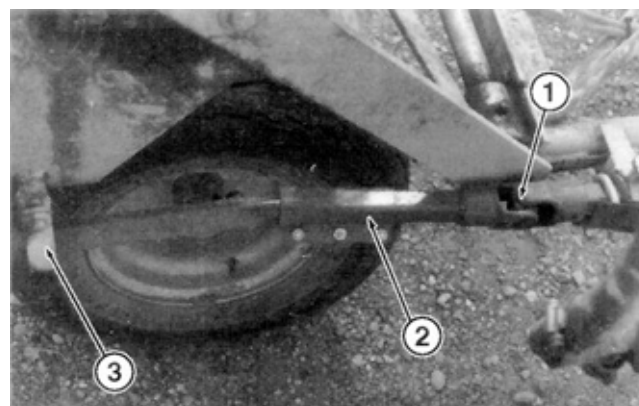

FIGURE 9. Wet Boom Carrier System: (1) Universal Joint, (2) Sleeve and (3) Bushings.

**Soil Compaction and Crop Damage:** Soil contact pressure beneath the sprayer wheels was less than an unloaded one-half ton truck. The soil contact pressure beneath the sprayer trailer wheels was 25 psi (175 kPa). The average soil contact pressures under the sprayer wheels with a full tank are given in TABLE 3.

Crop damage was minimal. The trailer and boom wheels travelled 2.3 and 1.7 percent of the total field area sprayed, respectively. Less crop damage was observed in the sprayer wheel tracks when spraying in crops less than 7 in (178 mm) tall. The AFMRC's studies show sprayer wheels should be run in tractor tracks. The combined

percentages of crop damage due to sprayer wheels and tractor wheels is greater than the damage when sprayer wheels are run in tractor tracks. Inland sprayer trailer wheels could not be adjusted.

**TABLE 3.** Soil Contact Pressure by Sprayer Wheels

SPRAYER WHEELS	TIRE TRACK WIDTH		AVERAGE SOIL CONTACT PRESSURE*	
	in	mm	psi	kPa
Trailer Wheels	12.25	310	25	175
Boom Wheels				
– Inner	3.75	95	29	200
– Outer	5.25	133	9	64

\*For comparative purposes, an unloaded one-half ton truck has a soil contact pressure of 30 psi (207 kPa).

### EASE OF OPERATION AND ADJUSTMENT

**Application Rate:** Ease of adjusting application rate was fair. The Inland sprayer was equipped with Spraying Systems nozzle body assembly that housed one nozzle tip. Adjusting application rate more than 20 percent required a different sized nozzle. Therefore, nozzle tips and possibly nozzle strainers had to be removed. The quick disconnect nozzle caps were quickly removed. However, removing the nozzle tips from the nozzle caps was inconvenient, as was inserting the different sized tips inside the caps. Sets of nozzles complete with nozzle caps was more convenient when changing application rate.

Adjusting application rate within a 20 percent range with the same nozzles was done by adjusting the ground speed and nozzle pressure. The XR11002VS extended range nozzles were operated at various pressures. Formulas and nozzle charts were used to calculate ground speed and nozzle pressure for the desired application rate.

**Controls:** Ease of operating the remote control console was very good. The Inland sprayer was equipped with a customized remote control console (FIGURE 10). The control system integrated boom folding, unfolding, nozzle height and pressure control in one dial. Turning the dial counterclockwise set-up the sprayer from transport to spraying condition. Turning the dial clockwise set-up the sprayer from spraying to transport position. This step by step procedure ensured the sprayer booms were properly positioned for spraying or transport.

The remote control console included a LCD bar graph which indicated nozzle pressure and nozzle height. The console included boom solenoid valve switches to control flow to the booms and a regulating switch to adjust nozzle pressure or height. Adjusting nozzle pressure and height was convenient.

The agitator and pump shut-off ball valves were mounted on the sprayer hitch frame and could not be operated from the tractor. Both valves were accessible and easy to use.

Tank liquid level indicator gave a rough indication of liquid level. The tank liquid level indicator was only reliable when the sprayer was stopped on level ground. Fluid level was difficult to see with certain chemicals and during cloudy days.

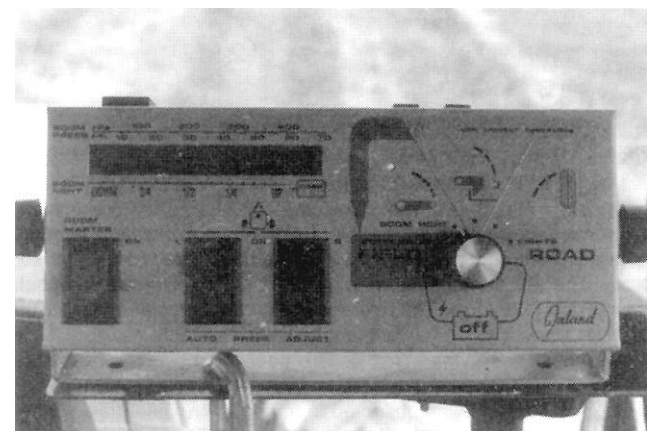

**FIGURE 10.** Inland remote control console.

**Caster Wheel Adjustments:** Ease of adjusting the boom wheels was very good. The middle boom wheels were toed-in slightly for proper boom alignment in transport position. One bolt on each boom wheel hydraulic cylinder had to be adjusted. Bolt adjustment was easy with the hydraulic cylinder on top of the boom wheel support frame. The trial and error procedure took 30 minutes before the booms trailed satisfactorily.

**Maneuverability:** Sprayer maneuverability was very good. The sprayer towed well in both field and transport position. The sprayer turning radius was 36 ft (11 m) in transport position. Care was exercised turning into farmyard approaches since the castor wheels did not follow the trailer tracks closely.

Backing up the sprayer in transport position for a short distance was possible, until the booms started unfolding.

**Boom Positioning:** Ease of boom positioning was very good. Positioning the booms from the tractor seat allowed getting in and out of fields quickly. The sprayer booms were placed into transport position in one minute. This involved raising the wet booms, unlocking the booms from the sprayer trailer, positioning the middle boom wheels parallel with the booms and then driving forward. In rough field conditions, over 100 ft (30 m) was travelled before the booms completely folded into transport position.

Placing the booms in field position took one minute and a distance of 45 ft (14 m) depending on operator experience and reverse speed. The procedure involved positioning the middle boom wheels perpendicular with the booms and backing up the sprayer until a green light on the console flashed. The flashing light indicated the booms were positioned correctly and could be locked. The right and left booms were unfolded evenly to avoid damage to the middle boom wheels. The dial and indicator lights on the control console made the procedure easy to follow. The dial activated or deactivated the hydraulic and electrical systems in the proper sequence.

Transport width was 8.3 ft (2.5 m) (FIGURE 11). Boom transport width was less than the width of the spray tank providing safe road transport.



**FIGURE 11.** Inland in transport position.

**Nozzle Adjustments:** Ease of adjusting nozzle height and angle was good. Nozzle angle was adjusted by loosening a U-bolt on each parallel linkage system and then rotating the wet spray booms. Spray interference with the castor wheels resulted when nozzle angle was adjusted more than 20 degrees forward on the extension booms. Nozzle angle remained constant at all boom heights.

Nozzle height was controlled with electrical linear actuators. The two actuators were operated from the control console. The actuators were slow in raising and lowering the booms. A LCD bar graph on the control console indicated the position of the wet boom centre line relative to the ground. Actual nozzle height was manually measured. The LCD height indicator was used for reference only, since actual nozzle height was not indicated. Nozzle height was automatically re-positioned to the desired height after the sprayer was placed in field position.

Nozzle height was adjusted from 9 to 30 in (230 to 760 mm) during the test. Maximum and minimum heights were adjustable and boom heights equalized by inserting or removing shims between the wet boom carrier bracket and actuator clevis.

Extension wet booms were 2 in (50 mm) lower than the inner booms because the wet boom carrier universal joints were loose.

**Tank Filling:** Ease of filling the spray tank was good. The 820 gal (3730 L) spray tank was filled through the filler opening. Sprayer tank filler opening was 66 in (1.7 m) above the ground and in front of the sprayer tank. There was easy access from the non-skid platform. The tank was filled from a nurse tank using a transfer pump. Care had to be exercised to prevent chemical foaming, splashing and contact with the spray tank. Adding a nozzle with a valve at the end of the transfer hose reduced splashing and solution contact. Time required to fill the spray tank averaged 10 minutes using a 2 in (50 mm) diameter hose.

An optional kit could be purchased to fill the tank through the bottom utilizing the sprayer pump. The AFMRC's past experience shows bottom reloading more convenient and safe, since less foaming and splashing occurs.

**Chemical Inducting:** Ease of adding chemical to the spray tank was good. The Inland sprayer was equipped with a 15 gal (70 L) easy-fill chemical tank (FIGURE 1). The easy-fill tank filler opening was 47 in (1.2 m) above the ground making it easy to lift chemical containers to. Caution was required to prevent chemical splashing. Dispersible granule formulations should be added through the spray tank filler opening.

The easy-fill chemical tank was near the pump shut-off valve, making chemical inducting easy. Chemical could also be inducted during agitation with the spray tank nearly full, thus reducing solution foaming. Both were convenient and preference depended on operator skill, time and amount the chemical foamed.

Less than one minute was required to induct the chemical from a full easy-fill tank. Closing the pump shut-off valve inducted the chemical faster. The pump had to be operated slowly, usually with the tractor idling, to prevent pump cavitation.

**Hitching:** Ease of hitching was very good. The joint coupler made it easy and safe to hitch the sprayer to a tractor with a 2.3 in (60 mm) ball hitch. The hitch jack provided was safe. In transport position with the spray tank empty the trailer hitch weight was 80 lbs (36 kg). The trailer hitch tipped up when lifted or working on the trailer. The hitch coupler was adjustable to level the spray tank trailer. Hitching included the hook-up of four hydraulic lines for the pump hydraulic motor and boom wheels, plus an electronic coupler for the remote control console.

**Cleaning:** Ease of cleaning the nozzle tips and strainers was good. Removing nozzle caps from Spraying Systems nozzle assemblies for cleaning was quick. Nozzle orifices were unplugged using a soft bristle toothbrush to prevent orifice damage.

Removing strainers from Spraying Systems nozzle assemblies was difficult at times. The top of the nozzle assemblies were tapped or the strainer pried with a screwdriver, causing chemical solution to splatter on the operator.

The pump inlet strainer was accessible from the right side of the hitch frame for removal. The strainer bowl was placed horizontally preventing chemical solution draining on the operator's hands.

**Draining:** Ease of draining the spray tank was very good. The spray tank was drained by disconnecting the pump suction line quick coupler. The quick coupler was near the pump. The quick coupler was easily reached, yet far enough away to prevent any rinseate from splashing on the operator. The sloped tank bottom made it possible to completely drain the tank.

The pump cavity was easily drained by opening the cock at the bottom of the pump. Draining the hoses was done by loosening the ring clamps and removing the hose ends. The spray booms were drained by removing the end plugs. Spraying Systems diaphragm nozzle body assemblies were difficult to drain. The diaphragm was removed to completely drain the nozzle body assembly. Using air pressure to pressurize the booms was more convenient to drain booms and nozzle assemblies for winter storage.

**Lubrication:** Ease of lubricating the sprayer was good. The Inland sprayer had 20 grease fittings that required greasing daily or every eight hours. Most grease fittings were easy to get to with a grease gun. Grease fittings on the wing lock pivots were difficult to access and to properly insert the grease gun nozzle. Ten minutes was required to lubricate the 20 grease fittings.

## PUMP PERFORMANCE

**Output:** Ace FMC Hyd 210 centrifugal pump output was good. In the sprayer system, the pump was operated at 4200 and 4600 rpm to adequately supply the 8002 and 8003 test nozzles, respectively. At 4600 rpm the pump delivered 13 gal/min (60 L/min) to the sprayer booms at a 40 psi (274 kPa) nozzle pressure. This was adequate to apply 15 gal/ac (165 L/ha) at a speed of 5 mph (8 km/h), using nozzles rated at 0.25 gal/min (1.1 L/min) (ie. 8003, 11003 nozzles). Larger sized nozzles were used with the agitator valve closed.

**Agitation:** Agitation output was very good. The Inland sprayer was equipped with two horizontally mounted, hydraulic agitators. TABLE 4 shows agitator outputs during various operating conditions using the 0.19 in (4.8 mm) diameter orifices. Agitation rates varied depending on pump speed, nozzle size and the amount the regulator and agitator valves were opened. Maximum agitation rates occurred with the agitator and regulator valves fully opened. In spraying conditions, the regulator valve was partially open to provide the desired spraying pressure. The flows shown in TABLE 4 are with the agitator valve opened and the regulator valve adjusted to produce a nozzle pressure of 40 psi (275 kPa).

Average agitator output was 40 gal/min (180 L/min) during field spraying. This exceeded recommended agitation rates for emulsifiable concentrates and wettable powders. Normally recommended agitation rates for emulsifiable concentrates such as 2,4-D are 1.5 gal/min per 100 gal (1.4 L/min per 100 L) of tank capacity. For wettable powders such as Atrazine, recommended agitation rates are 3.0 gal/min per 100 gal (3.0 L/min per 100 L) of tank capacity. During reloading, agitator output varied 33 to 44 gal/min (150 to 200 L/min) depending on pump speed.

The by-pass line returned to the top of the tank. This set-up provided additional agitation as shown in TABLE 4. During reloading, operating the regulator valve wide open increased total sprayer agitation. The regulator valve was fully open when nozzle pressure was adjusted to the lowest pressure.

TABLE 4. Agitation

OPERATING CONDITION	PUMP SPEED rpm	AGITATION			
		Agitator		By-pass	
		gal/min	L/min	gal/min	L/min
Reloading	3200	33	150	5	22
Reloading	4600	44	200	14	62
Field Spraying (11002)	4600	40	180	13	57

## OPERATOR SAFETY

The first section in the operator's manual emphasized operator safety. The manual discussed operating, chemical, maintenance, transport, hydraulic and tire safety. Four warning decals on the sprayer reminded the operator to wear rubber gloves and respirators while adding chemicals. Other decals cautioned the operator on the light hitch weight and proper maintenance around high pressure hydraulic lines. Clean water tank and easy-fill chemical tank increased spraying safety.

**Caution:** Operators are cautioned to wear suitable eye protection, respirators and clothing to minimize operator contact with chemicals. Although many commonly used agricultural chemicals may be relatively harmless to humans, they are a hazard if improperly used. In addition, little is known about the long-term effects of human exposure to many commonly used chemicals. In some cases, the effects may be cumulative, causing harm after continued exposure over several years.

## OPERATOR'S MANUAL

The operator's manual was very good. It was clearly written, well illustrated and followed practical order. Information was provided on safety, sprayer operation, service, maintenance, assembly, troubleshooting, specifications, parts and optional equipment.

## MECHANICAL PROBLEMS

TABLE 5 outlines the mechanical history of the Inland sprayer during 105 hours of operation while spraying 3397 ac (1375 ha). The intent of the test was evaluation of functional performance. An extended durability evaluation was not conducted.

TABLE 5. Mechanical History

ITEM	OPERATING HOURS	EQUIVALENT FIELD AREA	
		ac	ha
Pump hydraulic motor leaked and replaced	7	170	70
Tightened and replaced bolts on wet boom carrier extension sleeves	21	595	240
Tightened and replaced bolts on middle boom wheels	21	595	240
Right extension wet boom fell; extension sleeve was tightened	33, 41, 51, 71	895, 1236, 1460, 2250	360, 500, 590, 910
Right boom inlet house plastic ties broke; hose was re-fastened	33	895	360
Hydraulic solenoid valve leaked; plug was re-sealed	36	991	400
Tightened hydraulic hose clamp on hitch at	36	991	400
Pump impeller nut loosened off; nut was tightened	41	1236	500
Tightened hitch bolt	50	1460	590
Right middle boom wheel frame bent; replaced plate frame	50	1460	590
Middle boom wheel frame bolts loosened; replaced	53	1500	605
Tightened carrier boom clamps and actuator clevis nuts	53	1500	605
Re-sealed boom inlet tees and boom couplers; rerouted boom inlet hoses	53	1500	605
Left boom inlet hose failed; replaced	58	1680	680
Replaced right boom carrier sleeve	87	2865	1160

**DISCUSSION OF MECHANICAL PROBLEMS**

**Wet Boom Carrier Sleeves:** The sleeves (FIGURE 9) connecting the main and extension wet boom carrier loosened several times. The sleeve was tightened to the boom carrier by three bolts. The nuts worked loose and eventually the extension booms dropped to the ground. The nuts were tightened several times. The bolts broke when tightened too much. The right sleeve failed and was replaced near the end of the test. During this time it was difficult to adjust boom height and determine the stability of the boom. The wet booms also shifted when the wet boom carrier sleeves were loose. The AFMRC recommends the manufacturer make modifications to prevent the extension booms from dropping on the ground.

**APPENDIX I  
SPECIFICATIONS**

**MAKE:** Inland Auto-Fold Field Sprayer  
**MODEL:** Terminator I  
**SERIAL NUMBER:** 082  
**MANUFACTURER:** Inland Steel & Forgings Ltd.  
 675 Washington Avenue  
 Winnipeg, Manitoba  
 R2K 1M4  
 Phone: (204) 667-7854

**OVERALL DIMENSIONS:**  
 - trailer wheel tread 6.8 ft (1.85 m)  
 - transport height 5.8 ft (1.75 m)  
   - length 61.2 ft (18.6 m)  
   - width 8.3 ft (2.5 m)  
 - field height 5.8 ft (1.75 m)  
   - length 17.7 ft (5.4 m)  
   - width 90.6 ft (27.6 m)  
 - clearance height 12.0 in (300 mm)  
 - turning radius 36.0 ft (11 m)

**TIRES:**  
 - trailer two, 16.5 L x 16.1, 4 ply  
 - boom middle two, 20.5 x 8, 2 ply  
 - boom end two, 20 x 8, 4 ply

WEIGHT:	TRANSPORT POSITION	
	Empty	Loaded
- left trailer wheels	1225 lb (556 kg)	4870 lb (2209 kg)
- right trailer wheels	1250 lb (567 kg)	4925 lb (2234 kg)
- inner boom wheels - left	400 lb (181 kg)	400 lb (181 kg)
- right	400 lb (181 kg)	400 lb (181 kg)
- outer boom wheels - left	110 lb (50 kg)	110 lb (50 kg)
- right	110 lb (50 kg)	110 lb (50 kg)
- hitch	80 lb (36 kg)	960 lb (435 kg)
<b>TOTAL</b>	<b>3575 lb (1622 kg)</b>	<b>11775 lb (5341 kg)</b>

**FIELD POSITION**

	Empty	Loaded
- left trailer wheels	1225 lb (556 kg)	4870 lb (2209 kg)
- right trailer wheels	1250 lb (567 kg)	4925 lb (2234 kg)
- inner boom wheels - left	400 lb (181 kg)	400 lb (181 kg)
- right	400 lb (181 kg)	400 lb (181 kg)
- outer boom wheels - left	110 lb (50 kg)	110 lb (50 kg)
- right	110 lb (50 kg)	110 lb (50 kg)
- hitch	80 lb (36 kg)	960 lb (435 kg)
<b>TOTAL</b>	<b>3575 lb (1622 kg)</b>	<b>11775 lb (5341 kg)</b>

**SPRAY TANK:**

- material plastic  
 - capacity 820 gal (3730 L)  
 - agitation hydraulic, 4 jet agitators  
 - fresh water tank capacity 8.7 gal (40 L)

**FILLER OPENING:**

- shape round  
 - size  
   - small 5 in (121 mm) I.D.  
   - large 16 in (400 mm) I.D.  
 - location top, front, centre  
 - height above ground 66 in (1678 mm)

**CHEMICAL INDUCTOR:**

- type easy-fill tank  
 - capacity 15.2 gal (70 L)  
 - opening 8 in (200 mm) I.D.  
 - height above ground 47 in (1200 mm)

**STRAINERS:**

- pump inlet hose 1, 50 mesh  
 - nozzle assembly 54, 50 mesh  
 - spray tank 1, 16 mesh

**PUMP:**

- make Ace  
 - model FMC HYD 210  
 - type centrifugal  
 - operating speed 4600 rpm at hydraulic flow of 8.4 gal/min (38 L/min)  
 - type of drive hydraulic motor

**CONTROL CONSOLE:**

- make Inland  
 - pressure gauge LCD bar graph, 0 to 70 psi (0 to 475 kPa)

**SOLENOID VALVES:**

- make Gresen  
 - size two, 1 in (25 mm) NPT, 12 VDC

**SPRAY BOOM:**

- material aluminum  
 - size 1 in (25 mm)  
 - height adjustment  
   - type electric linear actuators  
   - range 9 to 30 in (230 to 760 mm)  
 - angle adjustment  
   - type manual rotation  
   - range 20 degrees forward, extension booms  
 - nozzle assembly  
   - make Tee Jet  
   - type split-eyelet diaphragm single nozzle  
   - number 54  
   - spacing 20 in (508 mm)  
   - cap quick-connect, colour coded, self-aligning  
   - effective spraying width 90 ft (27.4 m)

**APPENDIX II  
MACHINERY RATINGS**

The following rating scale is used in Alberta Farm Machinery Research Centre Evaluation Reports.

- Excellent
- Very Good
- Good
- Fair
- Poor
- Unsatisfactory



## SUMMARY CHART

### INLAND MODEL TERMINATOR I AUTO-FOLD FIELD SPRAYER

<b>RETAIL PRICE:</b>	\$14,020.00 (June, 1994 f.o.b. Lethbridge, Alberta)
<b>RATE OF WORK:</b>	76 ac/h (31 ha/h) @ 7 mph (11.3 km/h)
<b>QUALITY OF WORK:</b>	
- application rate	<b>good;</b> at constant tractor speed and nozzle pressure
- nozzle calibration (XR11002VS)	
- delivery	<b>good;</b> 2.3 percent higher than the manufacturer's rating
- wear	<b>good;</b> 2.5 percent increase after 92 hours
- CV	<b>very good;</b> about 1.3 percent
- spray distribution (XR11002VS)	<b>very good;</b> uniform above 20 psi (140 kPa) and 9 in (230 mm)
- spray drift (XR11002VS)	<b>fair;</b> at 40 psi (kPa) <b>good;</b> at 20 psi (140 kPa)
- pressure	
- loss	<b>very good;</b> less than 1 psi (7 kPa) across booms
- gauge	<b>fair;</b> 4 psi (25 kPa) low
- straining	<b>good</b>
- boom stability	<b>good;</b> wet boom less stable
- soil contact pressure	
- trailer	26 psi (175 kPa)
- castor	29 psi (200 kPa)
- crop damage	minimal
<b>EASE OF OPERATION AND ADJUSTMENT:</b>	
- application rate	<b>fair;</b> slow with single nozzle assembly
- controls	<b>very good;</b> one control console for most sprayer systems
- boom wheel adjustments	<b>very good;</b> less than 30 minutes
- maneuverability	<b>good</b>
- boom position	<b>very good;</b> less than a minute; control console guided sequence
- nozzle adjustment	<b>good;</b> extension boom height difficult to level
- tank filling	<b>good;</b> 10 minutes with transfer pump
- chemical inducting	<b>good;</b> easy-fill tank
- hitching	<b>very good;</b> safe with ball joint coupler
- cleaning	<b>good;</b> nozzle strainers difficult to remove
- draining	<b>very good;</b> quick coupler on suction line
- lubrication	<b>good;</b> 20 grease fittings
<b>PUMP PERFORMANCE:</b>	
- capacity	<b>good;</b> adequate capacity for 0.25 gal/min (1.1 L/min) nozzles
- agitation	<b>very good;</b> exceeded recommended rates
<b>OPERATOR SAFETY:</b>	improved with clean water tank, easy-fill chemical tank, hitch joint coupler
<b>OPERATOR'S MANUAL:</b>	<b>very good;</b> completed information on safety and operation
<b>MECHANICAL HISTORY:</b>	problems with boom carrier sleeves



**ALBERTA  
FARM  
MACHINERY  
RESEARCH  
CENTRE**

3000 College Drive South  
Lethbridge, Alberta, Canada T1K 1L6  
Telephone: (403) 329-1212  
FAX: (403) 329-5562  
<http://www.agric.gov.ab.ca/navigation/engineering/afmrc/index.html>

### **Prairie Agricultural Machinery Institute**

Head Office: P.O. Box 1900, Humboldt, Saskatchewan, Canada S0K 2A0  
Telephone: (306) 682-2555

#### Test Stations:

P.O. Box 1060

Portage la Prairie, Manitoba, Canada R1N 3C5

Telephone: (204) 239-5445

Fax: (204) 239-7124

P.O. Box 1150

Humboldt, Saskatchewan, Canada S0K 2A0

Telephone: (306) 682-5033

Fax: (306) 682-5080