

# Evaluation Report 281



## Walinga Model MT 510 Grain and Corn Vacuum (Power Take-off Drive)

A Co-operative Program Between



ALBERTA  
FARM  
MACHINERY  
RESEARCH  
CENTRE



PRAIRIE AGRICULTURAL MACHINERY INSTITUTE

# WALINGA MODEL MT 510 GRAIN AND CORN VACUUM

## MANUFACTURER:

Walinga Body and Coach Ltd.  
R. R. #5  
Guelph, Ontario  
N1H 6J2

## DISTRIBUTOR:

Thompson Vac Sales  
R.R. 5  
Calgary, Alberta  
T2P 2G6  
  
Schuh Distributors Ltd.  
Box 40  
Dilke, Saskatchewan  
S0G 1C0

**RETAIL PRICE:** \$13,500.00 (July, 1982, f.o.b. Lethbridge complete with standard package which includes 3 m (10 ft) of 102 mm (4 in) flexible pipe, 3 m (10 ft) of 127 mm (5 in) flexible pipe, 3.7 m (12 ft) of rigid aluminum pipe, intake nozzle, clean-up nozzle and discharge cyclone).

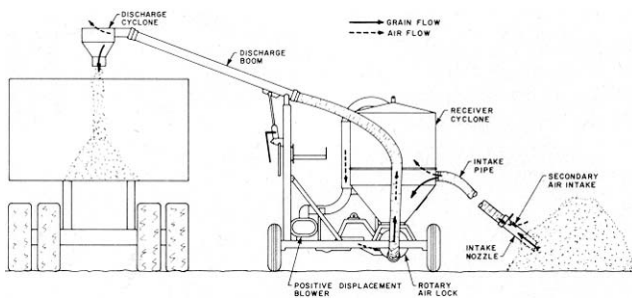

FIGURE 1. Schematic View Showing Air and Grain Flow.

## SUMMARY AND CONCLUSIONS

The functional performance of the Walinga MT 510 pneumatic grain conveyor was *very good* for conveying wheat, barley, oats and canola. Functional performance was lowered by high power consumption.

The maximum conveying rates obtained were 44.8 t/h (t650 bu/h) for wheat, 47.0 t/h (2160 bu/h) for barley, 42.0 t/h (2720 bu/h) for oats and 45.3 t/h (2000 bu/h) for canola. Conveying rates were reduced significantly when the intake pipe diameter was reduced and when intake or discharge pipe lengths were increased.

Power requirements while conveying grain varied from 36 to 47 kW (48 to 63 hp). A tractor with maximum power take-off output of at least 56 kW (75 hp) was required due to high starting torques and peak loading requirements.

The specific capacity of an average 178 mm (7 in) diameter grain auger was four and one-half times greater than that of the Walinga MT 510 in wheat and oats and three times greater in canola. This indicates that pneumatic conveying of grain is inefficient in terms of power required for the amount of grain moved when compared to a grain auger. However, pneumatic conveyors have advantages a grain auger doesn't have. For example, they are capable of conveying grain over longer distances, both vertically and horizontally, than is possible with a grain auger.

Crackage in dry wheat was less than 0.5% for each pass through the Walinga MT 510. This is similar to damage caused by grain augers.

The intake nozzles and pipe were easy to maneuver during bin clean-out. With the use of the flat nozzle attachments, complete clean-out could be accomplished. The discharge cyclone could be conveniently attached by lowering the discharge boom.

The Walinga MT 510 was much safer to use than a grain auger, especially for cleaning grain bins. Working near the inlet nozzle was clean as most dust was conveyed into the inlet. It was also safer than an auger since the operator was exposed to fewer moving parts. Noise levels adjacent to the conveyor varied from 94 to 98 dBA when operating in open areas. When operating close to metal bins the noise level was loud and irritating. It is recommended that an operator wear suitable ear protection when working near the Walinga MT 510.

Several mechanical failures occurred during the test. The polyurethane intake hose failed due to weathering, the spool valve on the flow divider seized due to rust and the jack handle for the hydraulic boom jack was easily bent and required replacing.

## RECOMMENDATIONS

It is recommended that the manufacturer consider:

1. Supplying guidelines for optimum secondary air settings for all common prairie grains.
2. Supplying optimum air lock speeds for all common prairie grains.
3. Moving the slow moving vehicle sign so that it is not obstructed from view by the discharge pipe or intake pipe when in transport position.
4. Supplying an updated operator's manual to conform to new model specifications.
5. Supplying an improved jack handle.

Senior Engineer: E. H. Wiens

Project Engineer: R. P. Atkins  
Project Technologist: G. A. Magyar

## THE MANUFACTURER STATES THAT

With regard to recommendation number:

1. A new operator's manual will supply guidelines for optimum secondary air settings for all common prairie grains.
2. Optimum air lock speeds for grains other than those presently listed in the operator's manual are to be added. However, they should be used as a guide only since optimum air lock speed can vary with changing conveying conditions.
3. The slow moving vehicle sign will be moved to the top of the receiver cyclone.
4. An updated manual is presently being prepared.
5. An improved jack handle is now being supplied.

**NOTE:** This report has been prepared using SI units of measurement. A conversion table is given in APPENDIX III.

## GENERAL DESCRIPTION

The Walinga Grain and Corn Vacuum model MT 510 is a 1000 rpm, power take-off driven pneumatic grain conveyor, mounted on a two wheel trailer. The positive displacement blower (FIGURE 1) provides both suction and discharge air to convey grain without passing it through the blower. Grain is conveyed by the intake airstream through the intake nozzle where it is drawn into the receiver cyclone. The grain is then separated from the air and the air is drawn through a nylon mesh filter before it enters the blower. The grain passes through the rotary air lock into the discharge airstream which delivers it to the discharge cyclone.

The blower is driven from the power take-off shaft by a multiple V-belt drive. The rotary air lock is hydraulically driven by the remote hydraulics on the tractor. The hydraulic motor is used in conjunction with a flow divider to control the speed of the air lock.

Intake and discharge locations can be varied by adding sections of rigid or flexible pipe. The 127 mm (5 in) diameter discharge pipe is available in both rigid and flexible galvanized steel. The 102 mm (4 in) and 127 mm (5 in) intake pipe is rigid aluminum, flexible galvanized steel or flexible polyurethane.

FIGURE 1 shows the location of major components while detailed specifications are given in APPENDIX I.

### SCOPE OF TEST

The Walinga MT 510 was used for 20 hours to convey the various grains shown in TABLE 1. It was evaluated for ease of operation and adjustment, rate of work, power requirements, quality of work, operator safety and suitability of the operator's manual.

TABLE 1. Operating Conditions

MATERIAL	QUANTITY CONVEYED (t)	HOURS
Spring Wheat	184.6	11
Winter Wheat	6.5	0.5
Durum	4.8	0.5
Barley	54.8	3.5
Oats	12.1	1
Canola	19.7	1.5
Flax	28.1	2
TOTAL	310.6	20

### RESULTS AND DISCUSSION

#### EASE OF OPERATION AND ADJUSTMENT

**Standard Discharge:** The standard discharge assembly (FIGURE 2) consisted of one 90° elbow and one 3.7 m (12 ft) section of 127 mm (5 in) diameter galvanized steel flexible pipe. This, in turn, was attached to a swing boom to which the discharge cyclone was attached. The swing boom was adjustable laterally and vertically with the aid of a hydraulic jack. The 3.7 m (12 ft) discharge height and 2.4 m (7.9 ft) reach were insufficient for filling grain bins but easily accommodated all common truck box heights. The 20 kg (44 lb) discharge cyclone was easily attached to the discharge boom when it was lowered to its minimum height of 1 m (3.3 ft). The discharge cyclone was equipped with replaceable polyurethane liners to prevent wear on the cyclone itself.

The discharge boom was also used to lift the top off the receiver cyclone to service the filter.

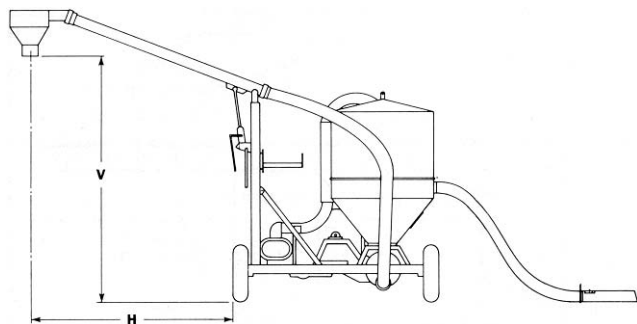

FIGURE 2. Standard Discharge Assembly ( $V = 3.4$  m,  $H = 2.4$  m).

**Conveying Pipe:** Rigid aluminum pipe sections were available in 3.05 m (10 ft) lengths while 3.7 m (12 ft) and 7.3 m (24 ft) lengths of flexible steel and polyurethane pipe were

available to vary inlet and discharge distances. Pipes were easily joined using quick couplers or bolted clamps. All joints, which were sealed with either rubber "O"-rings or wide rubber gaskets, were air tight.

**Intake Nozzles:** Two types of 102 mm (4 in) diameter intake nozzles and one 127 mm (5 in) diameter intake nozzle were available (FIGURE 3). The difference in the two, 102 mm (4 in) nozzles is that one was 0.6 m (2 ft) long and the other was 0.9 m (3 ft) long. The longer nozzle was more convenient for bin clean-out and the shorter nozzle was used for general conveying. Each size of intake nozzle could be equipped with a flat clean-out nozzle attachment (FIGURE 4). Complete bin clean-out could be accomplished with the flat clean-out nozzle attachments. A smooth sweeping action seemed to be the most effective way of bin cleaning. The 102 mm (4 in) diameter flexible pipe was best for bin clean-out. The flexible polyurethane pipe was easier to maneuver than the flexible steel pipe. Another handle on the flexible line would have facilitated maneuverability for bin clean-out.

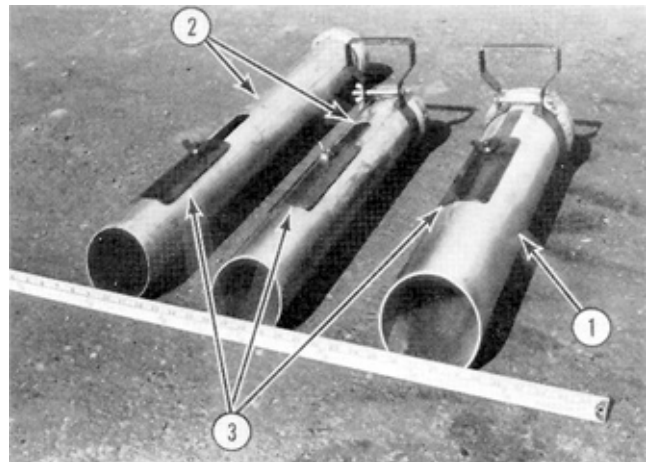

FIGURE 3. Intake Nozzles: (1) 127 mm Diameter Nozzle, (2) 102 mm Diameter Nozzles, (3) Adjustable Slide.



FIGURE 4. Bin Clean-out Nozzle Attachments.

**Filtering System:** Because of close tolerances, positive displacement blowers require a complete filtering of the conveying air after it has been separated from the grain in the receiver cyclone and before it enters the blower. To prevent dust and finely cracked grain from entering the blower, a large nylon mesh filter, supported by a cage (FIGURE 5), lined the outer extremities of the receiver cyclone. A filter inspection door was located on top of the receiver cyclone for convenient filter monitoring. Although no build-up of dust accumulated on the filter during normal operation, under very dusty conditions, it could plug and should be cleaned regularly. A thorough cleaning of the filter bag required lifting the top off the receiver cyclone with the discharge boom, removing the filter and cage and then blowing, vacuuming, or washing the filter. It took about one hour to remove and thoroughly clean the filter.

For handling fertilizer, a very fine mesh filter bag was available to prevent abrasive and corrosive fines from passing through the blower.

Care should be exercised if the Walinga MT 510 is used for conveying treated grain. Contamination of other grain could occur if the filter bag was not thoroughly cleaned following use in treated grain.

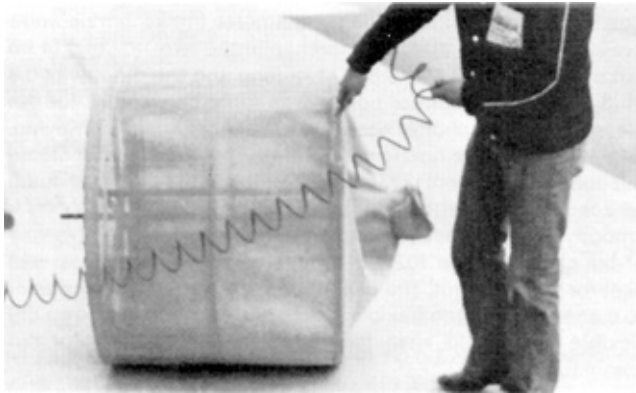

FIGURE 5. Filter Bag.

**Transporting:** The discharge boom could be easily swung into transport position by one person. The procedure included detaching the flexible discharge pipe from the discharge boom, unlocking the boom, swinging the boom into transport position and lowering the boom into the rest provided on top of the receiver cyclone (FIGURE 6). A saddle was provided to conveniently hold the flexible discharge pipe, intake pipe and nozzle for transport. Placing the MT 510 into transport position took less than 10 minutes.

The Walinga MT 510 was very compact and stable in transport position and could be safely towed at speeds up to 60 km/h (38 mph).



FIGURE 6. Transport Position.

**Hitching:** The Walinga MT 510 was easily hitched to tractors with a 1000 rpm power take-off. The hitch jack was convenient. The hitch clevis was not adjustable to suit varying tractor drawbar heights. Consequently, the conveyor could not be adjusted to operate level with all tractors used.

**Adjustments:** The blower drive belts were easily adjusted and aligned by two threaded adjusting rods located on each side of the main drive pulley.

The speed of the air lock was controlled by a flow divider. The speed could be conveniently set from 0 to 100 rpm by the position of the control arm in FIGURE 7.

The secondary air flow at the intake nozzle could be easily varied with the adjustable slide provided (FIGURE 3).

**Servicing:** The Walinga MT 510 had 8 grease fittings and two gear boxes and could be serviced in about 10 minutes. The operator's manual recommended various lubrication schedules for the grease fittings and gear boxes depending on the severity of the operating environment. All service points were easily accessible.

**RATE OF WORK**

**Maximum Conveying Rates:** Conveying rates for the Walinga MT 510 depended on the type of grain being conveyed,

speed of the air lock, the secondary air setting, the diameter of intake pipe and the length of intake and discharge pipe.

The conveying rate was very dependent on maintaining a steady flow rate. Highest conveying rates were obtained when the intake nozzle was completely submerged in grain and was used with one length of flexible intake pipe and the standard discharge assembly (FIGURE 2). As shown in TABLE 2 the maximum conveying rates for the 102 mm (4 in) intake pipe were 32.5 t/h (1190 bu/h) in spring wheat, 29.0 t/h (1880 bu/h) in oats, 34.6 t/h (1530 bu/h) in canola, and 27.6 t/h (1270 bu/h) in barley. For the 127 mm (5 in) intake pipe the conveying rates were 44.8 t/h (1650 bu/h) in spring wheat, 42.0 t/h (2720 bu/h) in oats, 45.3 t/h (2000 bu/h) in canola and 47.0 t/h (2160 bu/h) in barley. The use of steel or flexible polyurethane pipe had no pronounced effect on conveying rates. The wide range of conveying rates in TABLE 2 indicates the difficulty in adjusting the intake nozzle air opening and setting the rotary air lock speed to obtain maximum conveying rates.

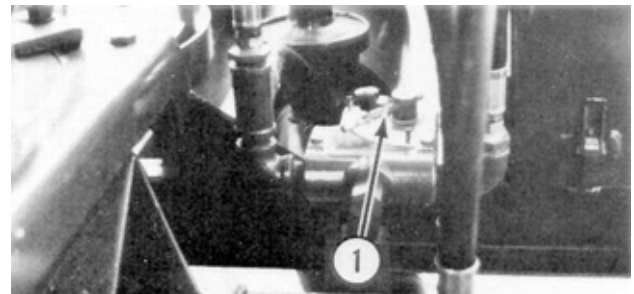
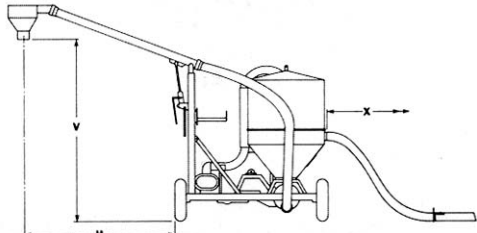
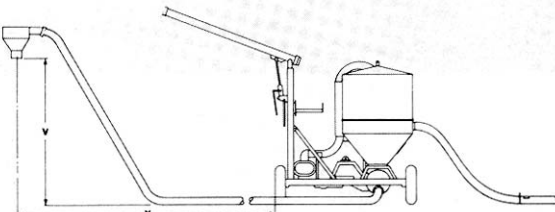

FIGURE 7. Hydraulic Flow Divider: (1) Spool Valve Control Arm.

TABLE 2. Conveying Rates at 1000 rpm Power Take-off Speed

Grain	Intake Pipe Length (X)				Discharge Pipe Length (Y)	
	102 mm		127 mm		15.2 m	30.5 m
	3.7 m	3.7 m	15.2 m	30.5 m		
Wheat	29.2 to 32.5 t/h	42.2 to 44.8 t/h	16.5 to 23.6 t/h	20.0 to 25.9 t/h	20.8 to 24.9 t/h	17.3 to 20.4 t/h
Barley	26.0 to 27.6 t/h	42.7 to 47.0 t/h		20.2 to 22.9 t/h		14.8 to 20.8 t/h
Oats	27.3 to 29.0 t/h	38.8 to 42.0 t/h		27.3 to 31.6 t/h		20.5 to 21.9 t/h
Canola	30.2 to 34.6 t/h	33.9 to 45.3 t/h		15.2 to 18.5 t/h		13.9 to 19.6 t/h

With Standard Discharge Assembly (FIGURE 2) and Various Intake Pipe Lengths (FIGURE 9).	Lift (V) = 3400 Reach (H) = 2420 mm
	
One Length of Flexible Intake Pipe and Various Discharge Pipe Lengths (FIGURE 10).	Lift (V) = 2900
	

**Secondary Air Setting:** The amount of secondary air introduced at the intake nozzle was important in obtaining maximum conveying rates. Too little secondary air resulted in blower overheating due to overloading and the machine tended to surge and could eventually plug. Too much secondary air resulted in inefficient conveying due to reduced suction at the intake. The secondary air setting depends on the density of the material being conveyed, size of intake pipe and length of conveying pipe. Optimum secondary air setting had to be established by trial and error for each grain conveyed. For example, using the standard intake and discharge assembly, the optimum settings in barley for the 102 mm (4 in) and 127 mm (5 in) diameter intake piping were 8 mm (0.3 in) and 4 mm (0.2 in), respectively (FIGURE 8). This resulted in respective conveying rates of 29 t/h (1332 bu/h) and 42 t/h (1929 bu/h). It is recommended the manufacturer provide similar guidelines for all common prairie grains.

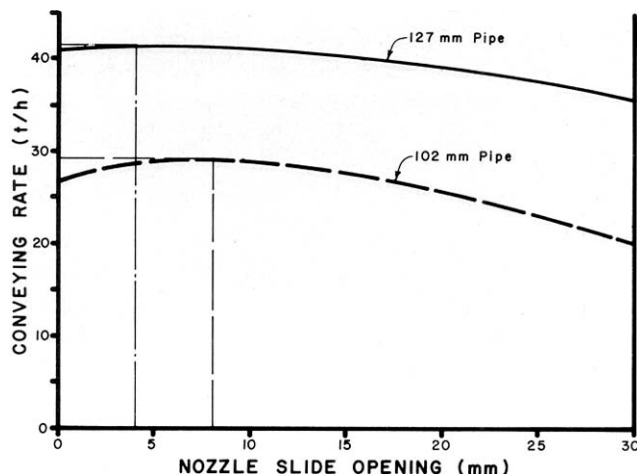

FIGURE 8. Conveying Rates in Barley for 102 and 127 mm Diameter Intake Pipe at Various Secondary Air Openings.

**Air Lock Speed:** The optimum air lock speed depended on the type of grain being conveyed, size of pipe used and the secondary air intake setting. Too slow an air lock speed resulted in the receiver cyclone plugging. Too fast an air lock speed reduced capacity and could also cause receiver cyclone plugging due to improper feeding of the air lock.

Recommendations for air lock speed were given in the operator's manual for wheat, barley and corn. The range of speeds provided was accurate and did result in maximum conveying rates. However, there was no correlation provided between the recommended speed and the position of the control arm on the flow divider. Consequently, a tachometer was required to set the recommended air lock speeds. It is recommended that the manufacturer provide air lock speeds for all common prairie grains.

**Effect of Pipe Length:** Conveying rates decreased with increased intake pipe length. Increasing the intake pipe length from 3.7 m (12 ft) to 30.5 m (100 ft) (FIGURE 9) reduced the maximum conveying rate from 44.8 to 25.9 t/h (1640 to 943 bu/h) in wheat, from 42.0 to 31.6 t/h (2720 to 2050 bu/h) in oats, from 45.3 to 18.5 t/h (2000 to 807 bu/h) in canola and from 47.0 to 22.9 t/h (2160 to 1050 bu/h) in barley.

Increasing the discharge pipe length also reduced the conveying rate. The standard discharge boom had a reach of 2.4 m (7.9 ft). Increasing the discharge length to 30.5 m (100 ft) (FIGURE 10) reduced the conveying rate in wheat from 44.8 to 20.4 t/h (1650 to 750 bu/h), in oats from 42.0 to 21.9 t/h (2720 to 1420 bu/h), in canola from 45.3 to 19.6 t/h (2000 to 864 bu/h) and in barley from 47.0 to 20.8 t/h (2160 to 955 bu/h).

**Filtering System:** There was no reduction in conveying rates due to dirty filters after continuous operation. Although filtering was not complete, the filter bag prevented most of the fines from passing through the blower. No loss in conveying or blower capacity was experienced as a result of possible wear on the

positive displacement blower during the 20 hour duration of the test.



FIGURE 9. Increased Intake Pipe Length.



FIGURE 10. Increased Discharge Pipe Length.

**Comparison to a Grain Auger:** TABLE 3 compares the performance of the Walinga MT 510 to that of an average 178 mm (7 in) diameter, 12.5 m (41 ft) long grain auger, at 30° inclination with a lift of 6.4 m (21 ft). Data for the Walinga MT 510 was obtained with the standard discharge at a 3.4 m (11 ft) lift and 3.7 m (12 ft) of 127 mm (5 in) diameter flexible intake pipe. The maximum conveying rate for the Walinga MT 510 was 9% greater than the grain auger in spring wheat, 49% greater than the grain auger in oats, and 15% greater than the grain auger in canola.

Specific capacity can be used to compare the conveying efficiency of the two methods of grain handling. A high specific capacity indicates efficient energy use while a low specific capacity indicates inefficient conveying. The specific capacity per metre of vertical lift for the grain auger was four and one-half times greater than that of the Walinga MT 510 in wheat and oats and three times greater in canola. This indicates that pneumatic conveying is inefficient as compared to a grain auger. However, pneumatic conveyors have advantages that grain augers do not have. They are capable of conveying grain over longer distances, both vertically and horizontally, than is possible with a grain auger. Pneumatic conveyors are also safer to operate than grain augers.

TABLE 3. Comparison of the Walinga MT 510 to an Average 178 mm Diameter Grain Auger<sup>1</sup>.

CONDITION	MAXIMUM CONVEYING RATES t/h		SPECIFIC CAPACITY/METER VERTICAL LIFT t/kWh	
	WALINGA MT 510	GRAIN AUGER	WALINGA MT 510	GRAIN AUGER
Wheat	44.8	41.0	0.28	1.25
Oats	42.0	28.2	0.34	1.53
Canola	45.3	39.4	0.33	1.03

#### POWER REQUIREMENTS

FIGURE 11 shows that the maximum power take-off input was 47.0 kW (63 hp) when the Walinga MT 510 was operating at maximum capacity in wheat. This compares to a power requirement of 7.3 kW (10 hp) when moving air only with the positive displacement blower equipped Walinga. Power input depended on the type of the material being conveyed. The heavier the material, the more resistance to flow the material

<sup>1</sup> Grain auger data represents average data results from Machinery Institute test reports 89, 90 and 92.

had and the greater the power input required. At maximum conveying rates, power requirements were 47.0, 44.6, 40.9 and 36.4 kW (63, 60, 55 and 49 hp) in wheat, barley, canola and oats, respectively.

A minimum tractor size of 50 kW (75 hp) was required to overcome peak power requirements. Peak power requirements occurred when the machine was on the verge of plugging.

The shear bolt in the power take-off drive line was considered a good feature to protect against extreme torque requirements. For example, when using tractors with hydraulic clutches that engage very quickly, high start-up torque resulted in the shear bolt failing several times. Engaging the power take-off slowly at the lowest possible idle speed prevented shear bolt failure.

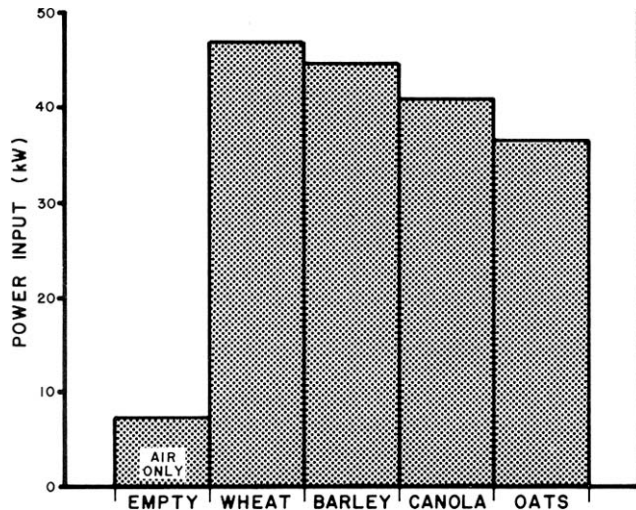

FIGURE 11. Power Requirements at Maximum Conveying Rates.

#### QUALITY OF WORK

**Grain Damage:** FIGURE 12 shows the increase in grain crackage each time a sample of dry wheat (11.3% moisture content) was conveyed. In these tests, the Walinga MT 510 was equipped with the standard discharge assembly (FIGURE 2) and a 3.7 m (12 ft) flexible intake pipe. The wheat initially contained 3.3% cracks. Each pass through the Walinga MT 510 caused an average of 0.5% increase in crackage. This indicates that if the number of passes is kept to a minimum, grain damage should not be a problem. Tests results 1 from grain augers in dry wheat have shown that each pass through an auger causes less than 0.2% crackage.

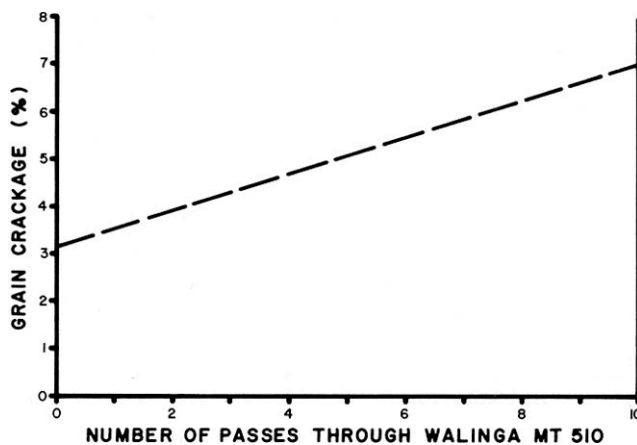

FIGURE 12. Grain Crackage in Dry Wheat.

**Plugging:** Plugging could occur in the intake line if insufficient secondary air entered the nozzle to carry the material being conveyed. Proper adjustment of the secondary air intake prevented plugging of the intake line. Plugging of the receiver cyclone occurred if the air lock speed was too slow or too fast. Proper adjustment of the air lock speed ensured an even flow

of material through the conveyor. Unplugging of the receiver cyclone or the intake line could be accomplished by discontinuing grain intake and allowing air to clear the blockage. Plugging of the discharge line occurred when longer lengths of pipe were used. To prevent damage to the blower, the Walinga MT 510 was equipped with a pressure relief valve and a vacuum relief valve (FIGURE 13). Occasionally, discharge line plugging caused the relief valve to release, necessitating manual unplugging of the discharge line.

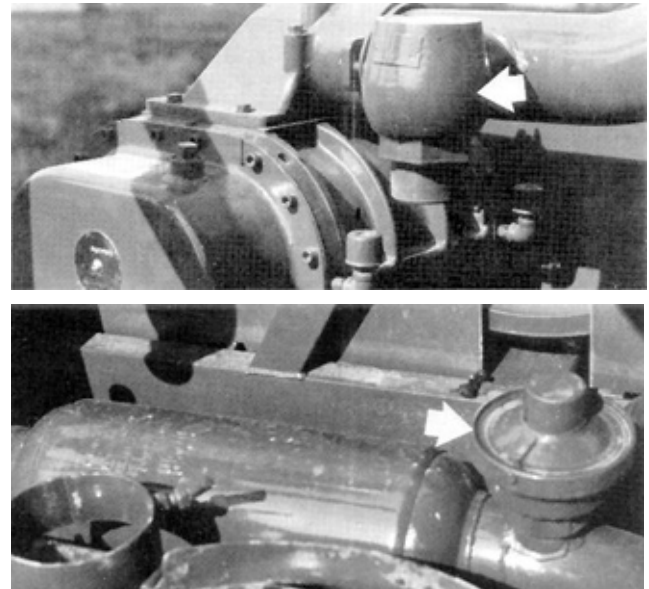

FIGURE 13. Relief Valves (Top: Pressure Relief Valve, Bottom: Vacuum Relief Valve.)

#### OPERATOR SAFETY

The Walinga MT 510 was safe to operate as all rotating parts were well shielded. The intake was much safer to operate than a grain auger since there was no exposed flighting or rotating parts. Working near the intake nozzle was virtually dust-free since most dust was conveyed into the inlet. Working near the discharge cyclone was, however, extremely dusty.

Peak noise levels<sup>2</sup> near the Walinga MT 510, when powered with an 80 kW (107 hp) tractor, varied from 94 to 98 dBA when operating on flat open fields. Noise levels when operating near metal bins or enclosed areas became very loud and irritating. The noise level was also very high when working near the discharge cyclone. It is recommended that an operator wear ear protection when working near the Walinga MT 510.

The Walinga MT 510 was low enough in transport position to pass safely under power lines. Its 2 m (6.6 ft) transport width allowed for safe road transport.

Although a slow moving vehicle sign was supplied, it was mounted too low on the receiver cyclone and was obstructed from view by the discharge pipe. It is recommended that the slow moving vehicle sign be moved to a more suitable location.

#### OPERATOR'S MANUAL

The operator's manual contained much useful information on operation, maintenance and lubrication. A complete parts list was supplied but requires updating to conform to new model specifications. It is recommended that the manufacturer update the operator's manual to include new model specifications.

#### MECHANICAL PROBLEMS

TABLE 4 outlines the mechanical history of the Walinga MT 510 during 20 hours of operation. The intent of the test was functional evaluation. The following failures represent those which occurred during functional testing. An extended durability evaluation was not conducted.

<sup>2</sup> PAMI T791, "Detailed Test Procedures for Determination of Noise Levels from Processing Equipment".

**TABLE 4. Mechanical History.**

ITEM	OPERATING HOURS
Piping	
- The 102 and 127 mm (4 and 5 in) diameter flexible polyurethane hose failed and was replaced at	7
Air Lock Drive	
- The flow divider valve seized and was repaired at	7
Swing Boom Jack	
- The jack handle was repeatedly bent and required replacing at	end of test

**DISCUSSION OF MECHANICAL PROBLEMS**

**Piping:** The 102 and 127 mm (4 and 5 in) diameter flexible polyurethane hose deteriorated (FIGURE 14) due to weather while being stored outside. The manufacturer replaced the hose with a rubber hose having better weathering characteristics. No further problems occurred for the remainder of the test.

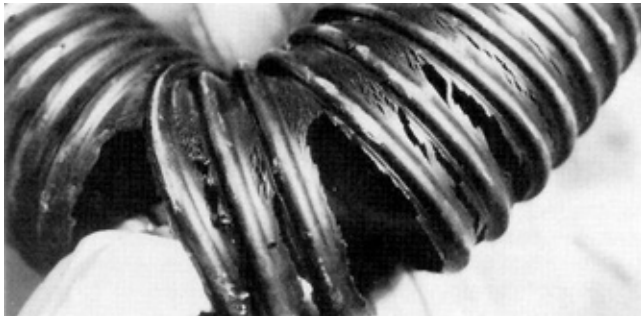

**FIGURE 14.** Failure of Polyurethane Hose due to Weathering.

**Air Lock Drive:** The flow control valve seized due to rust on the spool. After a thorough cleaning, the spool valve worked freely for the remainder of the test.

**Swing Boom Jack:** The jack handle was repeatedly bent each time it was used throughout the test. By the end of the test, the handle required replacing. It is recommended that the manufacturer supply an improved jack handle for the hydraulic boom jack.

<b>DRIVES:</b>		
- power take-off	1000 rpm	
- blower drive	5 V-belts	
- air lock	hydraulic motor	
<b>DISCHARGE CYCLONE:</b>		
- weight	20 kg	
<b>TIRES:</b>		
	2, 4-ply tubeless, 670-15	
<b>WEIGHT</b>		
	<u>FIELD POSITION</u>	<u>TRANSPORT POSITION</u>
- right wheel	344 kg	390 kg
- left wheel	336 kg	299 kg
- hitch	215 kg	206 kg
Total	895 kg	895 kg
<b>CENTRE OF GRAVITY:</b>		
- above ground	920 mm	920 mm
- forward of trailer axle	523 mm	502 mm
- in from left wheel	1085 mm	1183 mm
<b>OPTIONAL EQUIPMENT:</b>		
- 3 m length of 102 mm rigid aluminum pipe*		
- 3 m length of 127 mm rigid aluminum pipe*		
*supplied on test machine		

**APPENDIX II**

**MACHINE RATINGS**

The following rating scale is used in Machinery Institute Evaluation Reports:

- |               |                    |
|---------------|--------------------|
| (a) excellent | (d) fair           |
| (b) very good | (e) poor           |
| (c) good      | (f) unsatisfactory |

**APPENDIX III**

**CONVERSION TABLE**

1 meter (m)	= 3.3 feet (ft)
1 millimetre (mm)	= 0.04 inches (in)
1 tonne (t) = 1000 kilograms (kg)	= 2204.6 pounds (lb)
1 tonne per hour (t/h)	= 2204.6 pounds per hour (lb/h)
	= 36.74 bushel per hour (bu/h) for 60 lb/bu wheat
	= 45.93 bushel per hour (bu/h) for 48 lb/bu barley
	= 64.84 bushel per hour (bu/h) for 34 lb/bu oats
	= 44.09 bushel per hour (bu/h) for 50 lb/bu canola
1 kilowatt (kW)	= 1.34 horsepower (hp)
1 tonne per kilowatt hour (t/kWh)	= 27.42 bushel per horsepower hour (bu/hph)
	for 60 lb/bu wheat
	= 34.28 bushel per horsepower hour (bu/hph)
	for 48 lb/bu barley
	= 48.38 bushel per horsepower hour (bu/hph)
	for 34 lb/bu oats
	= 32.90 bushel per horsepower hour (bu/hph)
	for 50 lb/bu canola
1 kilometre/hour (km/h)	= 0.6 miles/hour (mph)

**APPENDIX I**

**SPECIFICATIONS**

<b>MAKE:</b>	Walinga Grain and Corn Vacuum		
<b>MODEL:</b>	MT 510		
<b>SERIAL NUMBER:</b>	3106494		
<b>MANUFACTURER:</b>	Walinga Body and Coach Ltd. R.R. #5 Guelph, Ontario N1H 6J2		
<b>DIMENSIONS:</b>	<u>FIELD POSITION</u>	<u>TRANSPORT POSITION</u>	
- overall length	2645 mm	2645 mm	
- overall height	4280 mm	2524 mm	
- overall width	5170 mm	2050 mm	
- wheel tread	2160 mm	2160 mm	
<b>INTAKE PIPE:</b>	102 mm or 127 mm diameter		
<b>DISCHARGE PIPE</b>	127 mm diameter		
	<u>TYPE</u>	<u>DIAMETER</u>	<u>LENGTH</u>
<b>FLEXIBLE:</b>	Polyurethane	102 mm	3700 mm
<b>PIPE:</b>	Steel	102 mm	3700 mm
	Steel	102 mm	7400 mm
	Polyurethane	127 mm	3700 mm
	Steel	127 mm	3700 mm
<b>RIGID PIPE:</b>	Aluminum	102 mm	3050 mm
	Aluminum	127 mm	3050 mm
<b>ROUND</b>		102 mm	2.3 kg
<b>NOZZLE:</b>		127 mm	3.2 kg
<b>CLEAN-UP NOZZLE</b>		102 mm	4.3 kg
<b>ATTACHMENT:</b>		127 mm	5.7 kg
	<u>MAXIMUM</u>	<u>MINIMUM</u>	
<b>DISCHARGE HEIGHT:</b>	3680 mm	1000 mm	
<b>REACH:</b>	2420 mm		
<b>NUMBER OF LUBRICATION POINTS:</b>	- 8 grease fittings, service based on severity of use		
	- 2 gear boxes, service based on severity of use		



**ALBERTA  
FARM  
MACHINERY  
RESEARCH  
CENTRE**

3000 College Drive South  
Lethbridge, Alberta, Canada T1K 1L6  
Telephone: (403) 329-1212  
FAX: (403) 329-5562  
<http://www.agric.gov.ab.ca/navigation/engineering/afmrc/index.html>

**Prairie Agricultural Machinery Institute**

Head Office: P.O. Box 1900, Humboldt, Saskatchewan, Canada S0K 2A0  
Telephone: (306) 682-2555

Test Stations:  
P.O. Box 1060  
Portage la Prairie, Manitoba, Canada R1N 3C5  
Telephone: (204) 239-5445  
Fax: (204) 239-7124

P.O. Box 1150  
Humboldt, Saskatchewan, Canada S0K 2A0  
Telephone: (306) 682-5033  
Fax: (306) 682-5080