

Evaluation Report

404



Haukaas Pull-Type Windrower Stabilizer Attachment

A Co-operative Program Between



ALBERTA
FARM
MACHINERY
RESEARCH
CENTRE



PRAIRIE AGRICULTURAL MACHINERY INSTITUTE

HAUKAAS PULL-TYPE WINDROWER STABILIZER ATTACHMENT

MANUFACTURER AND DISTRIBUTOR:

Haukaas Manufacturing Ltd.
Box 202
Mortlach, Saskatchewan
S0H 3E0

RETAIL PRICE:

\$285.00 (January, 1985, f.o.b. Humboldt).

SUMMARY AND CONCLUSIONS

Quality of Work: The ability of the Haukaas Stabilizer Attachment to control side skewing of a pull-type windrower was excellent. Side skewing was greatly reduced when operating up or across steep slopes and in soft soils.

Windrower maneuverability was excellent. The Haukaas Stabilizer did not restrict normal left or right turning of the windrower. The stabilizer folded up for transporting.

Ease of Installation: Ease of installing the Haukaas Stabilizer was very good. It took one man about 1-1/2 hours to install.

Ease of Operation and Adjustment: Ease of operating and adjusting the stabilizer attachment was very good. It was easily disconnected for transporting or when not required. Few adjustments were needed.

Operator Safety: No safety problems were apparent.

Operator's Manual: Installation instructions were adequate. An operator's manual was not available.

Mechanical History: No mechanical problems occurred during the test. Windrower hitch and frame stresses were not decreased or increased by the Haukaas Stabilizer, but the strong springs reversed the direction of the loads on the hitch.

RECOMMENDATIONS

It is recommended that the manufacturer consider:

1. Modifying the rear clamp and chain to permit proper installation in extended hitch positions.

Senior Engineer: G.E. Frehlich

Project Engineer: M.E. Jorgenson

THE MANUFACTURER STATES THAT

With regard to recommendation number:

1. New attachments will be supplied with a rear chain that will be 8 in (203 mm) longer to permit proper installation with the hitch in the extended positions. No modifications to the rear clamp would then be needed.

GENERAL DESCRIPTION

The Haukaas Stabilizer Attachment mounts on the right side of the hitch of a pull-type windrower. The two tension springs are chained to the right side of the tractor drawbar to resist sideways movement of the windrower in soft fields or on rolling land. Spring tension is adjusted by selecting different chain links on the tractor drawbar. The mounting arms fold ahead for transporting. In addition, a gauge bolts to the knife drive shield to indicate cutterbar height.

Detailed specifications are given in APPENDIX I.

SCOPE OF TEST

The Haukaas Stabilizer was mounted on a Massey Ferguson 35 pull-type windrower with a 28 ft (8.5 m) header. It was evaluated for quality of work, ease of installation, operation and adjustment, safety, and suitability of the operating instructions.

RESULTS AND DISCUSSION

QUALITY OF WORK

Windrower Stability: A pull-type windrower becomes unstable and skews sideways when the drag on the windrower becomes too great. Too much drag can occur when the cutterbar contacts the ground, when the wheels supporting the right side of the windrower sink into soft soil, or when windrowing up or across a steep hill. Little or no drag occurs when windrowing on firm, level ground or down a steep hill.

The ability of the Haukaas Stabilizer to maintain windrower stability was excellent. It greatly reduced skewing in soft soils and on rolling hills. For example, when windrowing up a steep slope of 15%, the stabilizer reduced skew by 50% (FIGURE 1). When operating across the same steep slope, skewing was almost completely eliminated (FIGURE 2). Forward skewing was not affected when operating downhill.

Windrower Maneuverability: Maneuverability with the Haukaas Stabilizer was excellent. It did not restrict normal turning of the windrower to the left or the right. Ground clearance was adequate. The Haukaas Stabilizer folded forward when unhooked and did not interfere with normal transporting of the windrower.

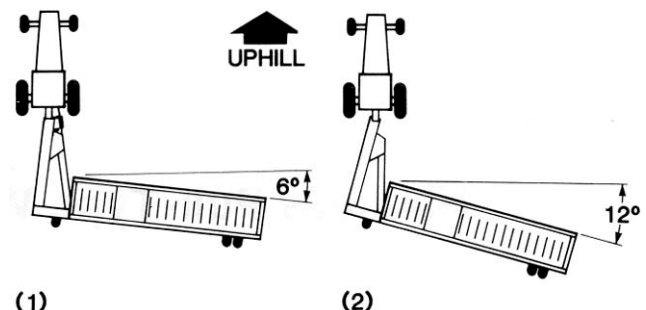

FIGURE 1. Windrower Skew When Operating Up a 15° Slope: (1) With the Stabilizer, (2) Without the Stabilizer.

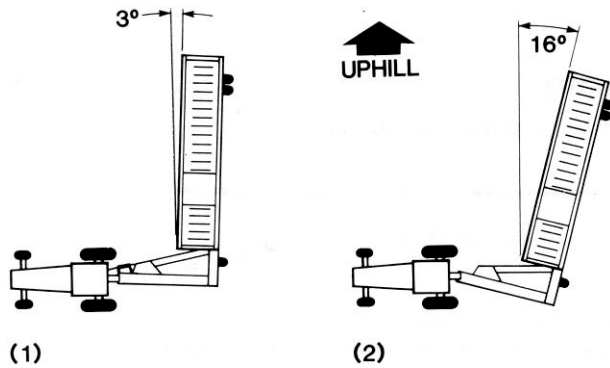

FIGURE 2. Windrower Skew When Operating Across a 15° Slope: (1) With the Stabilizer, (2) Without the Stabilizer.

EASE OF INSTALLATION

Ease of installing the Haukaas Stabilizer on the MF 35 windrower was very good. It was assembled and installed by one man in about one and one-half hours. Eleven bolts fastened the mounting arms and clamps in place on the windrower and tractor drawbar. A single sheet of illustrated instructions adequately explained installation.

When the windrower hitch was fully extended to adjust for a wide tractor, the rear clamp and chain of the Haukaas had to be installed as far forward on the hitch as possible. The bolts on the rear clamp came against a hitch brace and could not be tightened. It is recommended that the manufacturer consider modifying the rear clamp and chain to permit proper installation in extended hitch positions.

EASE OF OPERATION AND ADJUSTMENT

Ease of operation and adjustment was very good. The chains were easily connected by turning the tractor to the right. A cutting height gauge was supplied which, if properly positioned, aided in setting the cutterbar height.

Adjustments were rarely necessary. The tension on the springs was easily adjusted by hooking up a different chain link to the tractor drawbar. The rear clamp had to be repositioned when the windrower hitch was extended to suit different widths of tractors. A welded cleat on the hitch interfered with this adjustment, however, repositioning was rarely needed.

OPERATOR SAFETY

No safety hazards were apparent when operating the Haukaas Stabilizer under normal use.

OPERATOR'S MANUAL

An operator's manual was not supplied with the Haukaas Stabilizer, but the single sheet of installation instructions contained operating tips and an illustration.

MECHANICAL HISTORY

The stabilizer was operated in the field for about 10 hours. The intent of the test was evaluation of functional performance. An extended durability evaluation was not conducted. No mechanical problems occurred. Some caution was required not to overstretch the springs on a sharp left turn.

Windrower Hitch Stress: A windrower hitch and frame may be subjected to considerable stress due to the extra loading that occurs when the windrower skews sideways.

The Haukaas Stabilizer significantly reduced sideways skewing on steep hills and in soft soils. The two tension springs did not reduce the loads on the hitch, but instead applied the load in the opposite direction, especially during left turns. For example, the maximum draft with the stabilizer was -1945 lb (-8.66 kN) during a left turn. Maximum draft without the stabilizer was 1940 lb (8.65 kN) when windrowing up a 15° slope. Maximum side load on the hitch was -697 lb (-3.10 kN) with the stabilizer and 1152 lb (5.13 kN) without the stabilizer during these same operations.

Therefore, the Haukaas stabilizer did not increase or decrease stresses on the windrower hitch.

APPENDIX I

SPECIFICATIONS

MAKE & MODEL:	Haukaas Stabilizer
SERIAL NO.:	N/A
MANUFACTURER:	Haukaas Manufacturing Ltd Box 202 Mortlach, Saskatchewan S0H 3E0
DIMENSIONS:	
-- chain size	3/8 in (9.5 mm)
-- springs	
-- initial length	25.5 in (648 mm)
-- approx, preload	1200 lb (5.3 kN)
-- overall width	21 in (533 mm)
-- overall length	102 in (2590 mm)
-- total weight	77 lb (34.8 kg)
STABILIZER MECHANISM:	
-- type	tension springs attached between windrower hitch and tractor drawbar
-- spring factor (both springs)	275 lb/in (48 N/mm)
-- pulling point (centre of drawbar to chain)	10 in (254 mm)
OPTIONS:	
-- available to fit most makes of pull-type windrowers	

APPENDIX II

MACHINE RATINGS

The following rating scale is used in Machinery Institute Evaluation Reports:

excellent	fair
very good	poor
good	unsatisfactory

SUMMARY CHART
HAUKAAS PULL-TYPE WINDROWER STABILIZER ATTACHMENT

Retail Price	\$285.00 (January, 1985, f.o.b. Humboldt, Sask.)
QUALITY OF WORK	
Windrower Stability	excellent; greatly reduced skewing on steep slopes and in soft soils
Windrower Maneuverability	excellent; left and right windrower turns unrestricted, folded forward for transporting
EASE OF INSTALLATION	very good; took one man about 1-1/2 hours
EASE OF OPERATION AND ADJUSTMENT	very good; easily disconnected for transport, few adjustments needed
OPERATOR SAFETY	No safety hazards
OPERATOR'S MANUAL	No operator's manual, adequate installation instructions with operating tips
MECHANICAL HISTORY	No mechanical problems, stress on windrower hitch not increased or decreased



**ALBERTA
 FARM
 MACHINERY
 RESEARCH
 CENTRE**

3000 College Drive South
 Lethbridge, Alberta, Canada T1K 1L6
 Telephone: (403) 329-1212
 FAX: (403) 329-5562
<http://www.agric.gov.ab.ca/navigation/engineering/afmrc/index.html>

Prairie Agricultural Machinery Institute

Head Office: P.O. Box 1900, Humboldt, Saskatchewan, Canada S0K 2A0
 Telephone: (306) 682-2555

Test Stations:	
P.O. Box 1060	P.O. Box 1150
Portage la Prairie, Manitoba, Canada R1N 3C5	Humboldt, Saskatchewan, Canada S0K 2A0
Telephone: (204) 239-5445	Telephone: (306) 682-5033
Fax: (204) 239-7124	Fax: (306) 682-5080