

Evaluation Report 515

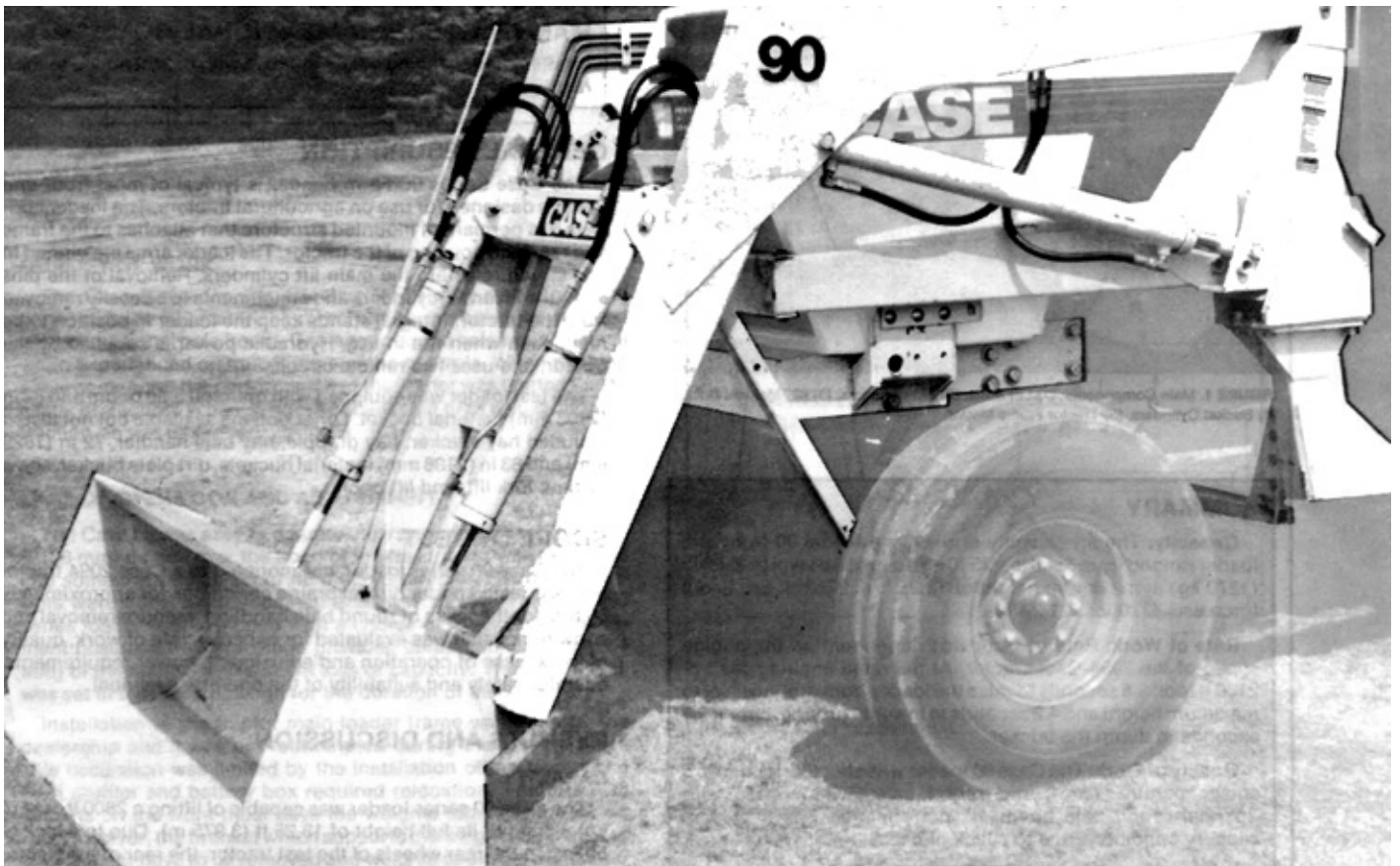

CASE MODEL 90 LOADER (For Case 2WD 90 Series Tractors)

A Co-operative Program Between



ALBERTA
FARM
MACHINERY
RESEARCH
CENTRE



PRAIRIE AGRICULTURAL MACHINERY INSTITUTE

CASE MODEL 90 LOADER (FOR CASE 2 WD 90 SERIES TRACTORS)

MANUFACTURER AND DISTRIBUTOR:

JI Case
Box 5051
240 Henderson Drive
Regina, Sask.
S4P 3M3

RETAIL PRICE: \$7,462.00 (March 1986, f.o.b. Portage la Prairie, Manitoba)



FIGURE 1. Main Components: (1) Lift Arms, (2) Lift Cylinders, (3) 83" Material Bucket, (4) Bucket Cylinders, (5) Tractor Frame Mount.

SUMMARY

Capacity: The lift capacity of the Case Model 90 front end loader ranged from 5500 lb (2500 kg) at ground level to 2800 lb (1270 kg) at maximum height of 13.25 ft (3.975 m). Break out force was 4770 lb (21,227N).

Rate of Work: Rate of work was dependent on the engine speed of the 2094 Case tractor. At the rated engine speed of 2100 it took 5.5 seconds to raise the loader from ground level to maximum height and 4.2 seconds to lower to ground, it took 5.1 seconds to dump the bucket.

Quality of Work: The Case 90 loader was effective for moving snow, manure, earth, and round bales, when fitted with optional round bale boom. Its performance was limited in slippery conditions due to a lack of ballast in the tractor tires.

Ease of Operation and Adjustment: The Case 90 loader was easy to operate, however, visibility over the hood of the tractor was limited and generally made accurate digging difficult. With a little practice, operators were able to accomplish work in an efficient and effective manner.

Power Requirements: The Case 90 Loader was compatible with Case 90 series tractors. The hydraulic systems and circuits were set up to match the closed centre circuits of the tractor.

Operator Safety: The Case Model 90 loader was safe to operate if normal safety precautions were followed.

Operator's Manual: The operator's manual was supplied on request and contained information on safety, specifications and operation. The manual was well written, illustrated & organized.

Mechanical History: Cracks developed around the bolt holes used to attach the optional bale boom to the bucket.

Attachment: The Case 90 loader was designed to be easily attached or removed from the tractor. It took one person about 10 minutes to attach or remove the loader.

RECOMMENDATIONS

It is recommended that the manufacturer consider:

1. Providing reinforcement for the bucket with use of the bale boom.

Senior Engineer- G.M. Omichinski

Project Technologist- R.K. Harris

THE MANUFACTURER STATES THAT

With regard to recommendation number:

1. The loader should have been equipped with the heavy duty 83 in bucket, instead of the standard 83 in bucket. The heavy duty 83 in bucket is recommended for use with bale boom and grapples.

MANUFACTURER'S ADDITIONAL COMMENTS

Lifting and handling would improve with ballast added to the rear tires.

GENERAL DESCRIPTION

The Case Series 90 Farm Loader is typical of most front-end loaders designed for use on agricultural tractors. The loader consists of a permanent mounted structure that attaches to the frame and rear axle housing of the tractor. The loader arms are pinned to this structure as are the main lift cylinders. Removal of the pins allow the lift arms, cylinders and attachments to be easily removed from the tractor. Integral stands keep the loader in position to be reattached when not in use. Hydraulic power is supplied by the tractor, and uses two remote circuits.

The test loader was equipped with optional bale boom and 83 in (2108 mm) material bucket. Other options available but not tested included hay stacker, hay grapple, hay bale handler, 72 in (1829 mm) and 83 in (2108 mm) material buckets, dirt plate bucket, snow bucket, fork lift, and lift boom.

SCOPE OF TEST

The Case 90 series loader was mounted to a Case 2094 tractor and was tested under typical prairie conditions for approximately 60 hrs. for the tasks of round bale handling, manure removal and snow removal. It was evaluated for capacity, rate of work, quality of work, ease of operation and adjustment, power requirements, operator safety and suitability of the operator's manual.

RESULTS AND DISCUSSION:

CAPACITY

The Case 90 series loader was capable of lifting a 2800 lb (1270 kg) weight to its full height of 13.25 ft (3.975 m). Due to a lack of ballast in the rear wheels of the test tractor, the rear of the tractor had to be chained down to prevent the wheels from lifting free of the ground during capacity tests. FIGURE 2 represents the lift capacity of the loader. Breakout force measured at the cutting edge of the bucket was 4770 lb (21,227 N).

RATE OF WORK

TABLE 1 represents operational time required to raise to maximum height, to lower to ground and to clump the bucket and then rollback the bucket. All measurements were taken with the bucket empty.

Rate of work was dependent on the engine speed of the tractor.

TABLE 1. Time to perform specific operations

	Engine Speed	
	2100 rpm (rated speed)	725 rpm (idle speed)
Raising Time	5.47 sec	16.80 sec
Lowering Time	4.20 sec	8.50 sec
Bucket Dumping Time	5.14 sec	9.20 sec
Bucket Rollback Time	6.86 sec	11.54 sec

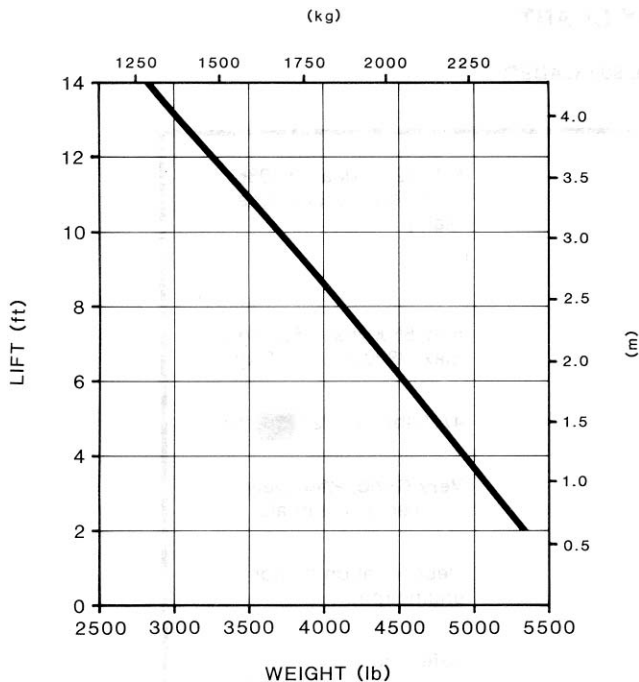

FIGURE 2.

QUALITY OF WORK

The Case 90 loader was effective for moving snow, manure, earth, with the 83 in material bucket, and round bales, when fitted with the optional bale boom. Damage to round bales was minimal when experienced operators were at the controls. When pushing snow or manure, the performance of the loader was limited due to a lack of traction. Wheel weights or ballasted tires would improve traction on wet or slippery surfaces.

EASE OF OPERATION AND ADJUSTMENT

The Case 90 was easy to operate, however, visibility of the 83 in (2108 mm) bucket over the hood of the test tractor was restricted and sometimes made accurate digging difficult. Hydraulic controls were conveniently located and easy to use. The Case 90 series loader was equipped with a choice of lift cylinder attachment positions. No. 2 position provided an additional 10 in (254 mm) of overall lift, with a slight loss of capacity. The unit tested, was set in the No. 2 position for the duration of the tests.

Installation of the tractor main loader frame was done by the dealership and it was not reattempted during the testing. Front axle oscillation was limited by the installation of the loader and both muffler and battery box required relocation. Tractors with weights on the front must have the weights removed for loader use. However, the bracket which supports the weights for the Case 2094 did not have to be removed and weights could be reattached when loader was parked. Disconnecting and reconnecting the loader from the tractor was simple and took one person about 10 minutes. Parking stands were provided and kept the disconnected loader in a position for easy attachment.

Lubrication requirements of the loader consisted of two grease fittings in each cylinder and four grease fittings in the main frame. All were conveniently located and easy to get at.

POWER REQUIREMENTS

The Case 90 loader required a tractor equivalent to the Case 90 series. Two remote hydraulic circuits were required, one to operate the lift cylinders, and the other to operate the bucket cylinders.

OPERATOR'S MANUAL

The operator's manual was well written and clearly illustrated. It contained detailed information on safety, general specifications, lubrication, operating instructions and optional attachments.

MECHANICAL HISTORY

Cracks appeared in the 83 in (2,075 mm) bucket where bolt holes for the optional bale boom were located. It is recommended that the manufacturer provide a means of reinforcing this area of the bucket where the bale boom is attached.

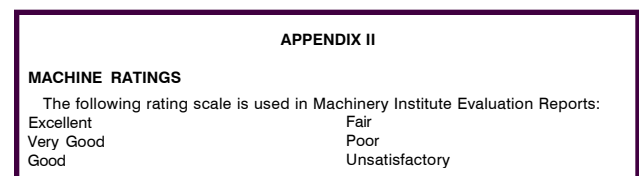
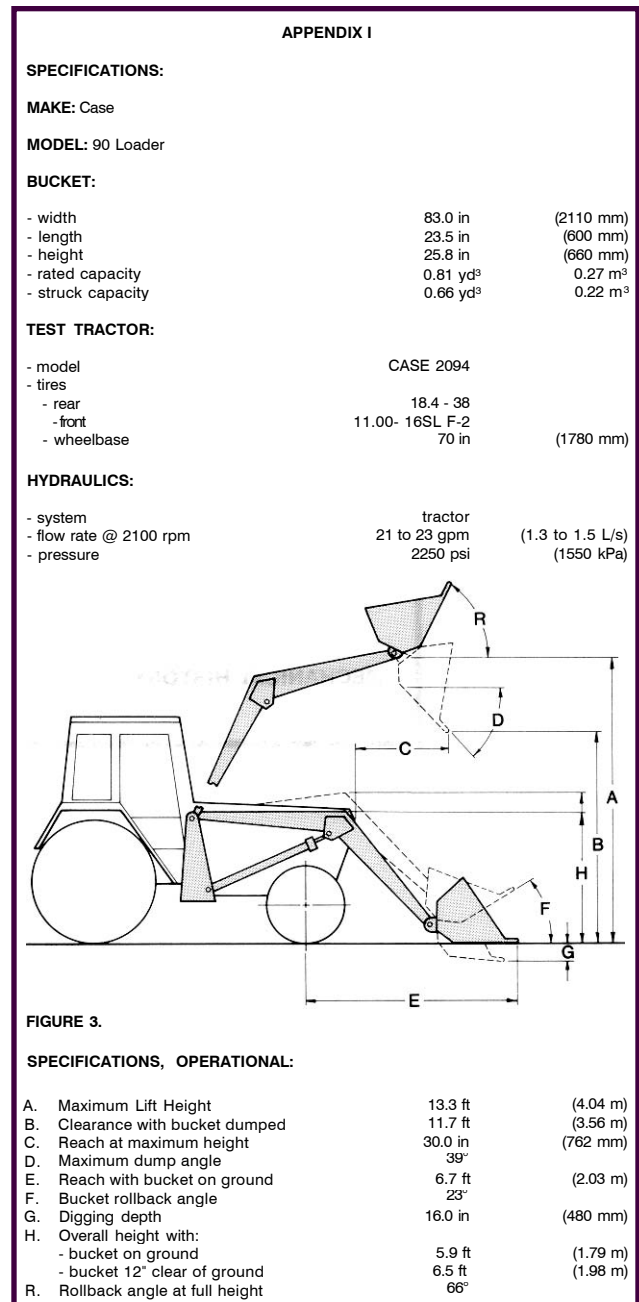

SUMMARY CHART

CASE MODEL 90 LOADER

RETAIL PRICE:	\$ 7,462.00 (March 1986, f.o.b. Portage la Prairie, Man.)
CAPACITY:	
- Height	min. 5500 lb (2500 kg) max. 2800 lb (1270 kg)
BREAKOUT FORCE:	4770 lb (21,227 kN)
EASE OF OPERATION:	Very Good , effectively handled all materials.
RATE OF WORK:	Dependent on tractor engine rpm.
OPERATOR SAFETY:	Safe if normal precautions were followed.
OPERATOR'S MANUAL:	Very well written and illustrated. Contained much useful information.
MECHANICAL HISTORY:	Cracks developed at bolt holes in bucket.



3000 College Drive South
Lethbridge, Alberta, Canada T1K 1L6
Telephone: (403) 329-1212
FAX: (403) 329-5562

<http://www.agric.gov.ab.ca/navigation/engineering/afmrc/index.html>

Prairie Agricultural Machinery Institute

Head Office: P.O. Box 1900, Humboldt, Saskatchewan, Canada S0K 2A0
Telephone: (306) 682-2555

Test Stations:

P.O. Box 1060

Portage la Prairie, Manitoba, Canada R1N 3C5

Telephone: (204) 239-5445

Fax: (204) 239-7124

P.O. Box 1150

Humboldt, Saskatchewan, Canada S0K 2A0

Telephone: (306) 682-5033

Fax: (306) 682-5080