

# Evaluation Report 135

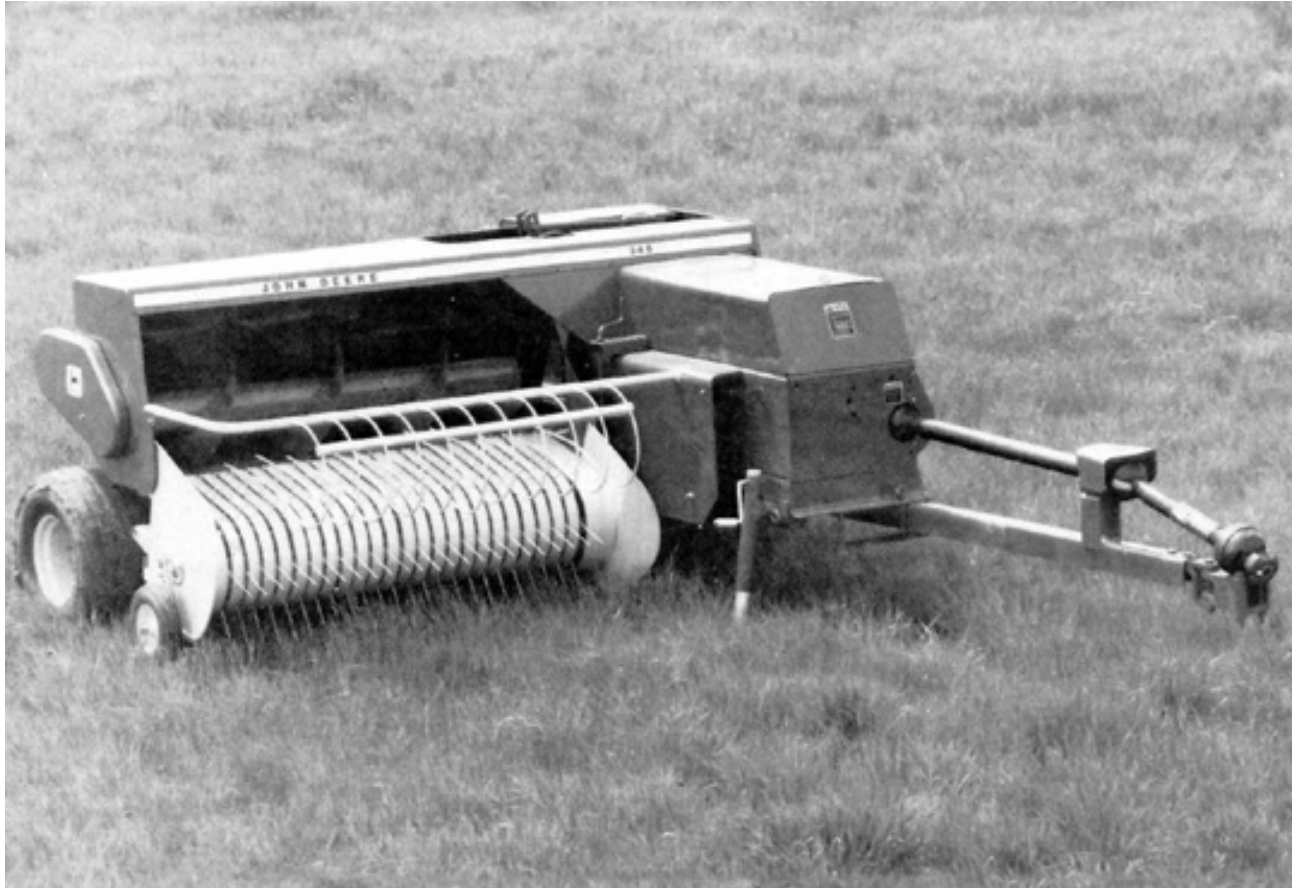

## John Deere Model 346 Baler

A Co-operative Program Between



PRAIRIE AGRICULTURAL MACHINERY INSTITUTE

# JOHN DEERE MODEL 346 BALER

## MANUFACTURER:

John Deere Ottumwa Works  
Ottumwa, Iowa 52501  
U.S.A.

## DISTRIBUTOR:

John Deere Limited  
455 Park Street  
Regina, Saskatchewan  
S4P 3L8

## RETAIL PRICE:

\$8,573.78 (April, 1979, f.o.b. Lethbridge, complete with pickup gauge wheel, side-drop bale chute, hydraulic bale density control and multi-luber).

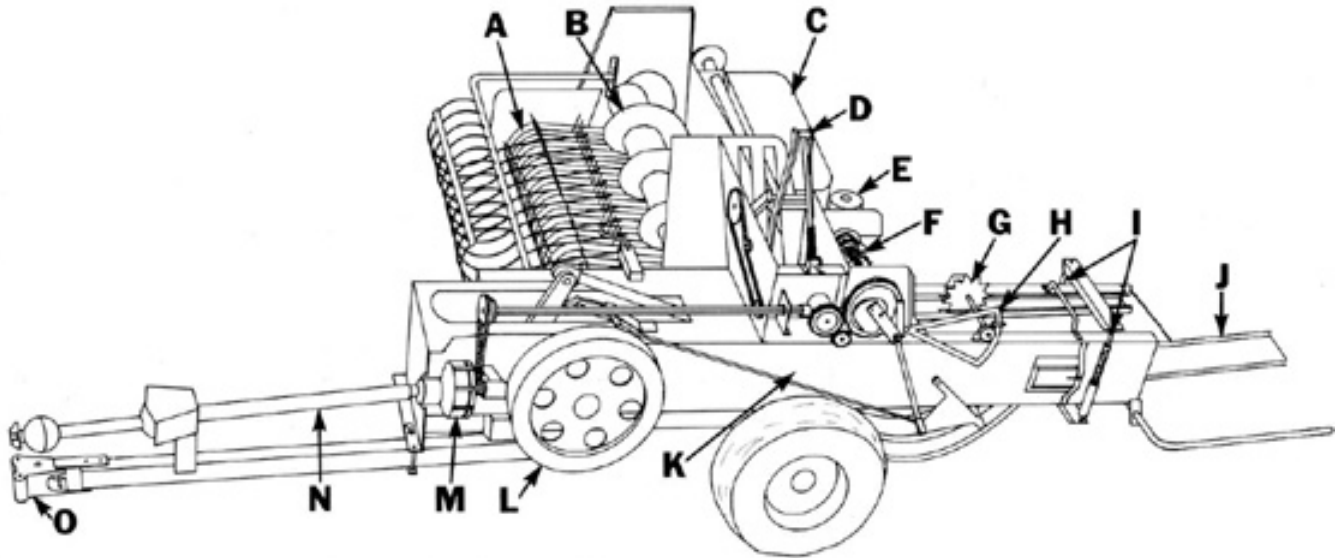

**FIGURE 1.** John Deere 346 Baler: (A) Pickup, (B) Feed Auger, (C) Twine Box, (D) Feed Fork, (E) Hydraulic Bale Density Pump and Control, (F) Knotter, (G) Metering Wheel, (H) Metering Arm, (I) Hydraulic Bale Density Rams, (J) Bale Chute, (K) Bale Chamber, (L) Flywheel, (M) Slip Clutch, (N) Power Shaft, (O) Equal Angle Hitch Attachment.

## SUMMARY AND CONCLUSIONS

Overall functional performance of the John Deere 346 baler was *very good*.

Average feedrates varied from 4 to 10 t/h (4.4 to 11 ton/h). Field speeds were usually limited to 10 km/h (6.2 mph) due to bouncing on rough ground and reduced pickup performance at higher speeds. Maximum instantaneous feedrates in excess of 20 t/h (22 ton/h) were measured in heavy uniform alfalfa windrows. Feeding was aggressive in all crops.

The John Deere 346 was capable of producing firm, well-formed bales. Length of the 356 x 457 mm (14 x 18 in) bales could be adjusted from 305 to 1270 mm (12 to 50 in). Bale length variation, at the 1000 mm (39 in) length setting, was about 160 mm (6.3 in). For a certain length setting, longer bales were usually produced at higher feedrates. Average hay bales weighed from 27 to 37 kg (59 to 81 lb), while average straw bales weighed from 21 to 24 kg (46 to 53 lb). Bale density varied from 220 kg/m<sup>3</sup> (13.7 lb/ft<sup>3</sup>) in heavy alfalfa to 125 kg/m<sup>3</sup> (7.8 lb/ft<sup>3</sup>) in straw.

The John Deere 346 was easy to operate and adjust. Knotter performance was satisfactory as long as the knotters were properly adjusted. Normally, the billhooks had to be changed and the twine disc timing adjusted when changing from heavy sisal twines to synthetic twines.

Average power requirements were usually less than 28 kW (38 hp) but a 45 kW (60 hp) tractor was needed to overcome power take-off power fluctuations and to provide sufficient power on hilly and soft fields.

Leaf loss was usually less than 4%, similar to that of other conventional square balers.

The John Deere 346 was safe to operate if the manufacturer's safety recommendations were closely followed and normal safety precautions were observed.

Only minor mechanical problems occurred during the test: The slip clutch plates had to be cleaned to remove a grease deposit. Two slip clutch ratchet pins broke.

## RECOMMENDATIONS

It is recommended that the manufacturer consider:

1. Modifications to prevent the "equal angle hitch" fasteners from loosening during field operation.

Chief Engineer: E. O. Nyborg

Senior Engineer: E. H. Wiens

Project Engineer: K. W. Drever

## THE MANUFACTURER STATES THAT

With regard to recommendation number:

1. In early 1978, a production change was made to correct the problem of fasteners on the equal angle hitch loosening. With all balers produced after February 1978, the hitch was changed to adopt interlocking "V" grooved retaining washers for positive retention of the hitch fasteners during field operation.

## GENERAL DESCRIPTION

The John Deere Model 346 is a pull type, 540 rpm, power take-off driven, automatic twine tie baler. A floating drum pickup delivers hay to the feed chamber, where it is fed into the 356 x 457 mm bale chamber by an auger and a feeder fork. Hay is compacted and bales formed by a slicing plunger operating at 80 strokes/min.

The test machine was equipped with an optional hydraulic bale density control consisting of two hydraulic rams operated by a baler mounted pump and control.

FIGURE 1 shows the location of major components while detailed specifications are given in APPENDIX I.

## SCOPE OF TEST

The John Deere 346 was operated in a variety of crops (TABLE 1) for 119 hours while producing 16 210 bales. It was evaluated for rate of work, quality of work, power consumption, ease of operation, ease of adjustment, operator safety and suitability of the operator's manual.

TABLE 1. Operating Conditions.

CROP	HOURS	NO. OF BALES	FIELD AREA (ha)
Alfalfa	41	6828	69
Alfalfa, Bromegrass	41	5423	53
Bromegrass	5	491	12
Crested Wheatgrass	6	544	12
Green Feed	1	97	1
Wheat Straw	24	2714	44
Oat Straw	1	113	1
TOTAL	119	16,210	192

**RESULTS AND DISCUSSION**

**RATE OF WORK**

Average feedrates varied from 4 t/h in light bromegrass to 10 t/h in a heavy alfalfa-brome. Average feedrate depended on windrow size and uniformity, crop condition, field surface, available tractor speeds and operator skill. Speeds were normally limited to about 10 km/h, due to bouncing on rough ground and poorer pickup performance at higher speeds.

In heavy, uniform alfalfa windrows, instantaneous feedrates in excess of 20 t/h were measured. These were peak values, representing maximum baler capacity, which could not be maintained continuously.

Feeding was aggressive in all crops.

**QUALITY OF WORK**

**Bale Quality:** The John Deere 346 was capable of producing firm durable bales, with square ends, in all crops (FIGURE 2). Average hay bales weighed 27 to 37 kg while average straw bales weighed 21 to 24 kg. Average bale density varied from 220 kg/m<sup>3</sup> in heavy alfalfa to 125 kg/m<sup>3</sup> in straw.

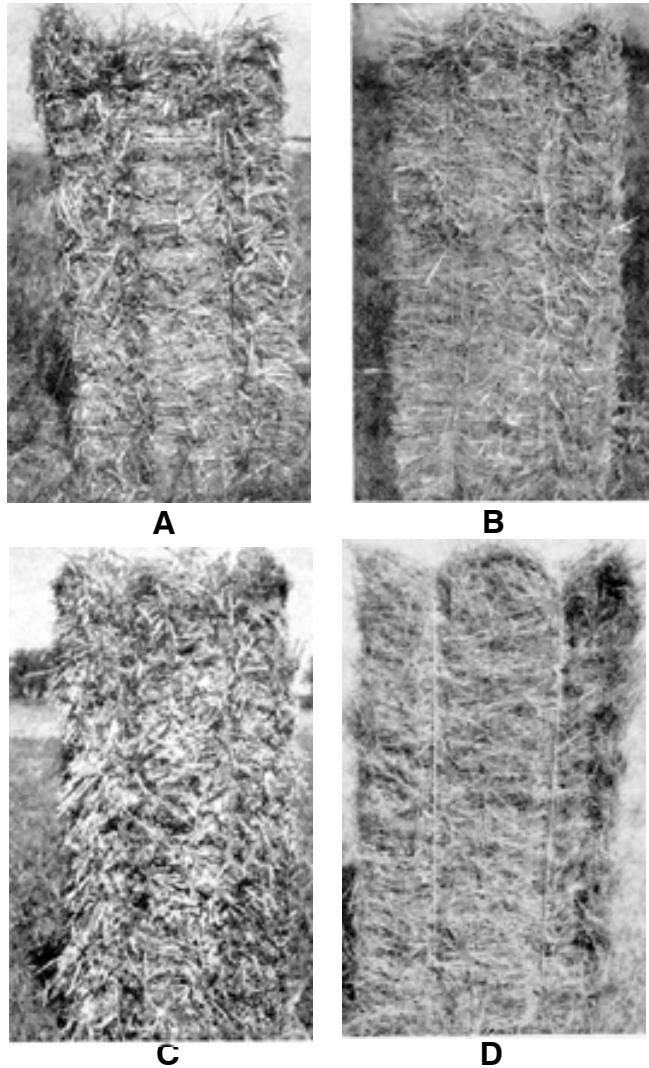

FIGURE 2. Typical Bales: (A) Alfalfa, (B)Straw, (C)Green Feed, (D)Crested Wheatgrass..

**Bale Length Variation:** As with most conventional square balers, it was difficult to obtain consistent bale length, especially in non-uniform windrows. When set for 1000 mm length, bale lengths typically varied from 920 to 1080 mm.

Bale length is adjusted by positioning the metering arm stop (FIGURE 3). The metering wheel advances the metering arm with each plunger stroke. Bale length uniformity depends on a consistent number of plunger strokes to form each bale. If the metering arm trips at the beginning of the last plunger stroke, rather than at the end of the stroke, bale length is increased by the length of compressed hay delivered during the last plunger stroke. Uniform feedrates are therefore important in reducing bale length variation.

For the same length setting, higher feedrates usually produced longer bales. For example, in a uniform alfalfa field, average bale length was 1000 mm when baling at 5 t/h but increased to 1090 mm at 15 t/h. The same trend was evident in wheat straw with average bale length increasing from 960 mm at 3 t/h feedrate to 1070 mm at 15 t/h.

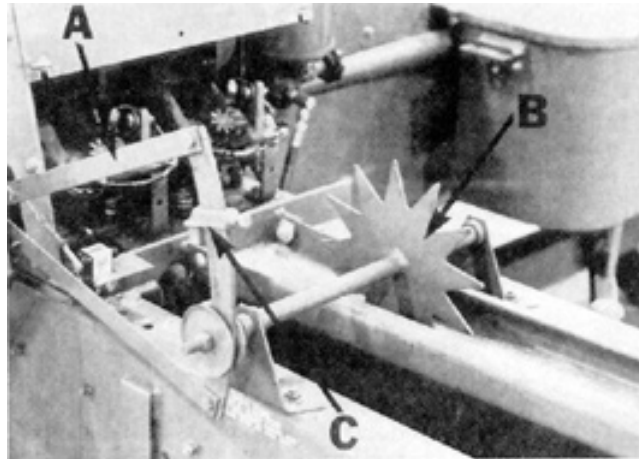

FIGURE 3. Bale Length Adjustment: (A) Metering Arm, (B) Metering Wheel, (C) Adjustable Stop.

**Leaf Loss:** As with most conventional square balers, leaf loss in dry hay was lower than with round balers. Total loss from the pickup and bale chamber was less than 4% in most field conditions. Pickup losses were normally insignificant unless ground speed was very high or windrows were light and poorly formed.

**Knotter Reliability and Performance:** The knotters, when properly adjusted, performed satisfactorily with most twines. Most knotter adjustments, with the exception of twine disc timing, were clearly outlined in the operator's manual.

The John Deere 346 was supplied with multi-twine billhooks. With heavy sisal twines it was usually necessary to change to sisal billhooks and to adjust twine disc timing. This took one man, with tools, about 45 minutes.

Knot strength was about 50% of twine tensile strength with synthetic twines and about 40% of twine tensile strength with sisal twines.

**POWER CONSUMPTION**

**Power Take-off Requirements:** FIGURE 4 shows typical instantaneous power take-off requirements for the John Deere 346. Power requirements fluctuated from 0 to 46 kW on each plunger stroke. Due to these wide power fluctuations, average power requirements were less than instantaneous requirements, varying from 6 to 23 kW, over a full range of feedrates. FIGURE 5 shows the average power take-off requirements at various feedrates in alfalfa and wheat straw.

**Tractor Size:** The manufacturer recommended that a 26 kW tractor be used. Average power take-off requirements were usually less than 23 kW and power required to pull the baler on level ground was usually less than 5 kW. A 45 kW tractor was, however, needed to fully utilize baler capacity in soft or hilly fields and to overcome the power fluctuations illustrated in FIGURE 4.

**Specific Capacity:** Specific capacity is a measure of how efficiently a machine performs a task. A high specific capacity

indicates efficient energy use while low specific, capacity indicates inefficient operation. The specific capacity of the John Deere 346 varied from 0.7 to 0.9 t/kW.h in alfalfa and was about 0.6 t/kW.h in wheat straw. This compares to an average specific capacity of 0.5 t/kW.h for large round balers in alfalfa. These values represent average conditions and not peak outputs.

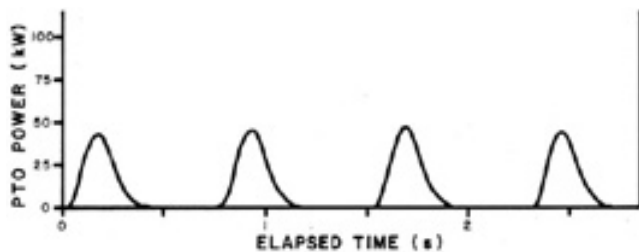

FIGURE 4. Instantaneous Power Take-off Requirements when Baling Alfalfa at 10 t/h Feedrate.

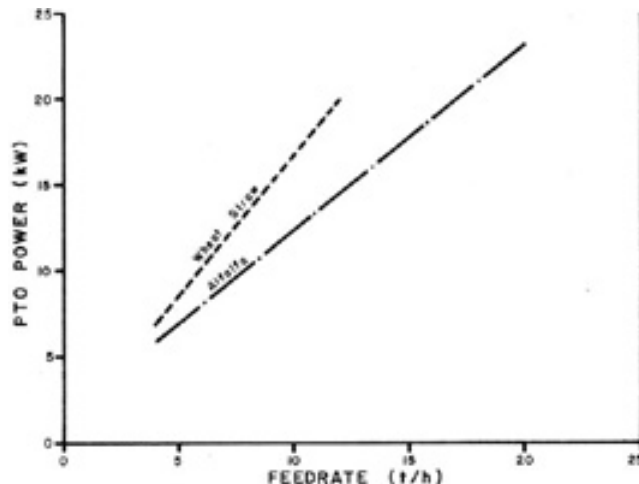

FIGURE 5. Average Power Take-off Requirements when Baling Alfalfa and Straw.

## EASE OF OPERATION

**Hitching:** The John Deere 346 was easily hitched to tractors equipped with a 540 rpm power take-off. The hitch jack was convenient. The hitch clevis was adjustable to suit drawbar height.

The John Deere 346 was supplied with an "equal angle hitch" attachment which bolts as an extension to the tractor drawbar. This design reduces driveline noise and permits 90° turns while baling. The equal angle hitch was difficult to fasten securely to the tractor drawbar since the attaching bolts often loosened during operation. It is recommended that the manufacturer consider modifications to prevent this occurrence.

**Transporting:** The hitch tongue was easy to swing into transport or field position. Dismounting the tractor was necessary to fold the bale chute, raise the pickup, and to remove and insert the hitch tongue retaining pin. The John Deere 346 could normally be placed into transport or field position in about three minutes.

The baler towed well behind a tractor or suitably sized truck.

**Feeding:** Feeding was aggressive and positive in all crops with only infrequent plugging. The pickup, was wide enough to accommodate most windrows with minimal trampling by the rear tractor tire. Pickup and feed chamber visibility were excellent from most tractors.

**Maneuverability:** The John Deere 346 was sufficiently maneuverable for efficient baling. The equal angle hitch minimized power take-off chatter on short turns.

**Twine Threading:** Twine threading was convenient. The operator's manual gave a clear description of twine threading procedures and a twine threading diagram was provided on the twine box lid.

## EASE OF ADJUSTMENT

**Bale Length:** Bale length was conveniently adjusted with a wrench. Bale length settings from 305 to 1270 mm were possible.

Obtaining a consistent bale length was difficult, since bale lengths varied, depending on windrow uniformity and feedrate.

**Bale Density:** The optional hydraulic bale density control was easy to adjust although it was necessary to dismount the tractor. Setting the control valve for a specific crop was a trial and error procedure.

The bale density control had sufficient adjustment range to produce dense bales in most crops. Normally, twine knot strength was the only factor limiting bale density. In very light windrows or very slippery hay, the side resistors (FIGURE 6) had to be adjusted to obtain proper bale density. Side resistor adjustment was convenient.

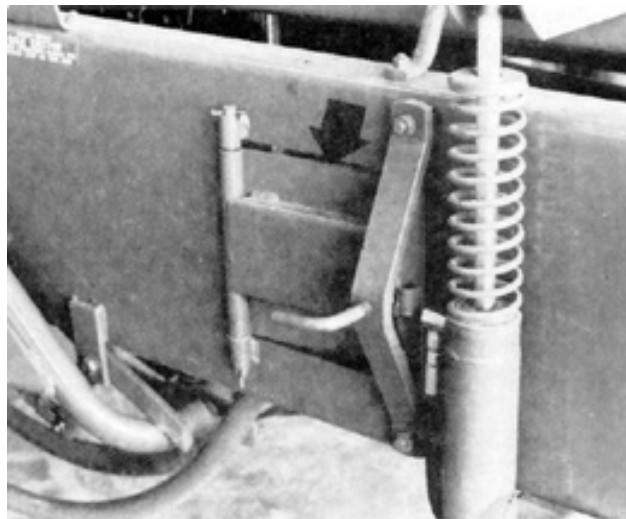

FIGURE 6. Side Resistors.

**Feeding System:** The feeder fork (FIGURE 1) had three settings which were adequate to produce square, well formed bales in all crops. The feeder fork was easily adjusted with pliers.

**Pickup:** Pickup height was easily adjusted with a screw crank. Wrenches were needed to position the optional pickup gauge wheel.

**Overload Devices:** The drive shaft slip clutch functioned well but required adjustment once during the test. Adjusting the slip clutch was easy. Replacing the flywheel and knottor shear bolts was convenient.

**Bale Chute:** The optional quarter turn bale chute was easily adjusted to place the bales on edge. The bale chute was reversible so bales could be dropped on either the left or right side.

**Servicing:** The John Deere 346 had three chain drives, 12 grease fittings, one multi-luber and one gear box. The operator's manual recommends chain oiling every 10 hours, lubrication of the knottor with the multi-luber every 10 hours, lubrication of six grease fittings every 50 hours, six grease fittings every 100 hours and annual gearbox servicing and wheel bearing packing. About seven minutes were needed to service the John Deere 346. Shields made lubrication of the power shaft universal joint grease fittings awkward. Lubrication of the plunger bearing was also awkward.

**Tool Box:** A tool tray located above the plunger crank was convenient for carrying tools, spare shear bolts or spare parts.

## OPERATOR SAFETY

The John Deere was safe to operate and service if normal safety precautions were observed. All moving parts, except for the flywheel, were well shielded. As with most power take-off equipment, the power take-off must be disengaged and the tractor engine stopped before adjusting or servicing.

## OPERATOR'S MANUAL

The operator's manual was clear, well written and contained much useful information on operation, servicing, adjustments and safety procedures.

## DURABILITY RESULTS

TABLE 2 outlines the mechanical history of the John Deere 346 during 119 hours of field operation while baling 16,210 bales. The intent of the test was functional evaluation. The following failures represent only those which occurred during functional testing. An extended durability evaluation was not conducted.

TABLE 2. Mechanical History

Item	Operating Hours	Equivalent Bales
<i>Plunger</i>		
- The bolt threads on the front left plunger scraper were stripped due to overtightening. A nut was welded to the scraper to reinforce the threads at	7	950
- The bottom angle on the plunger guide was adjusted to eliminate a plunger knock at	88	11,990
<i>Knotter Assembly</i>		
- A bolt on the knotter trip mechanism was lost, causing the baler to tie on every plunger stroke. The bolt was replaced at	27	3680
- The twine box tension plate, bolt and spring were lost and replaced at	60	8170
<i>Drive Train</i>		
- The slip clutch began to slip excessively. It was disassembled and cleaned at	30	4090
Both pins on the slip clutch ratchet were broken and replaced at		
	End of Test	

## DISCUSSION OF MECHANICAL PROBLEMS

**Slip Clutch:** The slip clutch began to slip excessively at 30 hours due to a film of grease or oil on the clutch plates. The film was removed with emery paper and the clutch reassembled. No further problems occurred.

## APPENDIX I

### SPECIFICATIONS

MAKE: John Deere 540 rpm Power Take-off Baler

MODEL: 346

SERIAL NUMBER: 382109 E

#### OVERALL DIMENSIONS:

width	2970 mm
length	5970 mm
height	1714 mm
ground clearance	240 mm

#### WEIGHTS: (field position)

left wheel	821 kg
right wheel	395 kg
hitch	200 kg
Total	1416 kg

#### TIRES:

left	11 L x 14, 6 ply rib implement
right	26 x 12, 4 ply rib implement
pickup gauge	12 x 3, semi pneumatic

#### PICKUP:

type	cam actuated drum pickup
height adjustment	screw crank
overall width	1780 mm
number of tooth bars	6
number of teeth	144
tooth spacing	61 mm
speed	80 rpm

#### FEEDING MECHANISM:

type	auger and feed fork
auger diameter	406 mm
auger speed	210 rpm
feed fork speed	80 strokes/min

#### PLUNGER:

strokes per minute	80
length of stroke	762 mm

#### BALE CHAMBER:

width	457 mm
height	356 mm
range of bale lengths	305 to 1270 mm
bale density control	compression bars (primary) adjustable side resistors (secondary)
	4 balls

#### TWINE CAPACITY:

#### DRIVES:

number of belt drives	2
number of chain drives	3
number of gear drives	2
number of universal joints	3

#### SAFETY FEATURES:

power take-off slip clutch	
flywheel shear bolt	
knotter drive shear bolt	
plunger safety stop	

#### SERVICING:

grease fittings	
(every 50 hours)	6
(every 100 hours)	6
multi-luber	
(every 10 hours)	lubricates 12 knotter locations
chains	
(oil every 10 hours)	3
gearbox	1
wheel bearings	2

#### OPTIONAL EQUIPMENT:

bale ejector	
sisal billhook	
pickup gauge wheel*	
plungerhead extensions	
side hay resistors*	
wagon hitch	
bale chute extension	
side-drop bale chute*	
hitch straps	
lights	
hydraulic bale density control*	
multi-luber*	

\* supplied on test machine

## APPENDIX II

### MACHINE RATINGS

The following rating scale is used in PAMI Evaluation Reports:

(a) excellent	(d) fair
(b) very good	(e) poor
(c) good	(f) unsatisfactory

## APPENDIX III

### METRIC UNITS

In keeping with the Canadian metric conversion program, this report has been prepared in SI units. For comparative purposes, the following conversions may be used.

1 hectare (ha)	= 2.47 acres (ac)
1 kilometre/hour (km/h)	= 0.62 miles/hour (mph)
1 tonne (t)	= 2204.6 pounds (lb)
1 tonne/hour (t/h)	= 1.10 ton/hour (ton/h)
1 tonne/hectare (t/ha)	= 0.45 ton/acre (ton/ac)
1000 millimetres (mm) = 1 metre (m)	= 39.37 inches (in)
1 kilowatt (kW)	= 1.34 horsepower (hp)
1 kilogram (kg)	= 2.20 pounds mass (lb)
1 kilogram/cubic metre (kg/m <sup>3</sup> )	= 0.06 pounds mass/cubic foot (lb/ft <sup>3</sup> )
1 tonne/kilowatt hour (t/kW-h)	= 0.82 tons/horsepower hour (ton/hp.h)



**ALBERTA  
FARM  
MACHINERY  
RESEARCH  
CENTRE**

3000 College Drive South  
Lethbridge, Alberta, Canada T1K 1L6  
Telephone: (403) 329-1212  
FAX: (403) 329-5562  
<http://www.agric.gov.ab.ca/navigation/engineering/afmrc/index.html>

**Prairie Agricultural Machinery Institute**

Head Office: P.O. Box 1900, Humboldt, Saskatchewan, Canada S0K 2A0  
Telephone: (306) 682-2555

Test Stations:  
P.O. Box 1060  
Portage la Prairie, Manitoba, Canada R1N 3C5  
Telephone: (204) 239-5445  
Fax: (204) 239-7124

P.O. Box 1150  
Humboldt, Saskatchewan, Canada S0K 2A0  
Telephone: (306) 682-5033  
Fax: (306) 682-5080