

Evaluation Report 136



New Holland Model 320 Baler

A Co-operative Program Between



NEW HOLLAND MODEL 320 BALER

MANUFACTURER:

Sperry New Holland
 A Division of Sperry Rand Corporation
 New Holland, Pennsylvania 17557
 U.S.A.

RETAIL PRICE:

\$10,249.80 (April, 1979, f.o.b. Lethbridge, complete with plunger face extension kit, quarter turn bale chute, hydraulic bale density control and flotation tires).

DISTRIBUTORS:

Sperry New Holland
 Box 777, Winnipeg, Manitoba
 Box 1907, Regina, Saskatchewan
 Box 1616, Calgary, Alberta

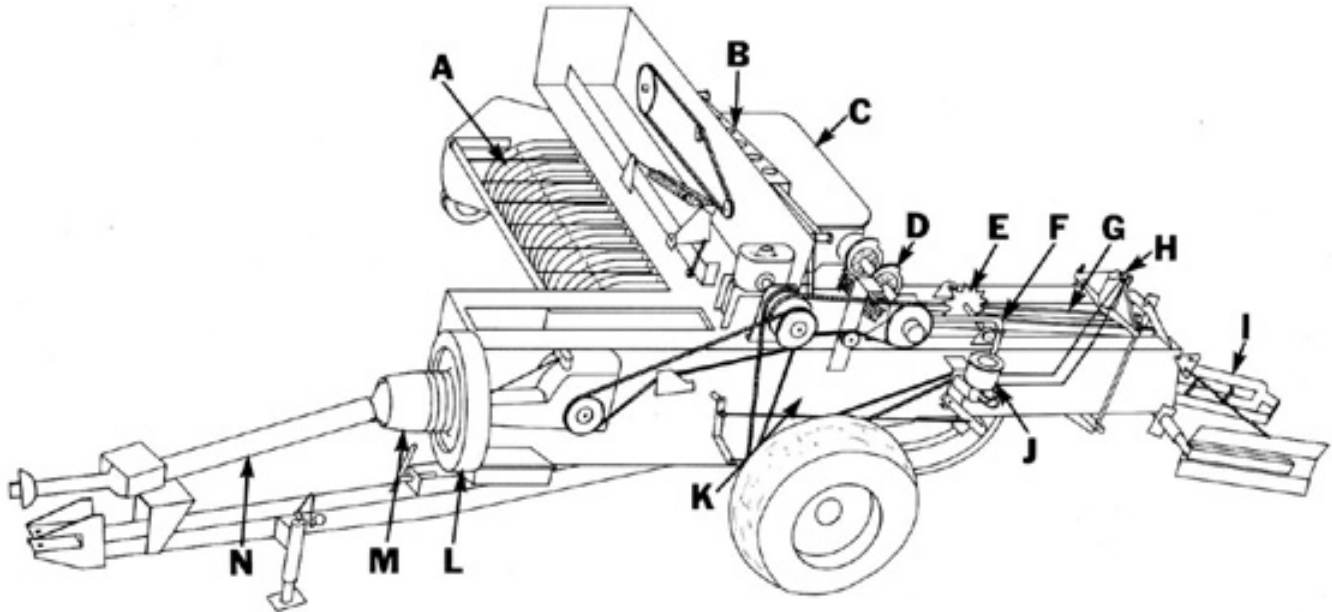

FIGURE 1. New Holland 320 Baler: (A) Pickup, (B) Tine Bar Feeder, (C) Twine Box, (D) Knotter, (E) Metering Wheel, (F) Metering Arm, (G) Pressure Bar, (H) Hydraulic Bale Density Ram, (I) Bale Chute, (J) Hydraulic Bale Density Pump and Control (K) Bale Chamber, (L) Flywheel, (M) Slip Clutch, (N) Power Shaft.

SUMMARY AND CONCLUSIONS

Overall functional performance of the New Holland 320 baler was *very good*.

Average feedrates varied from 4 to 14 t/h (4.4 to 15.4 ton/h). Field speeds were usually limited to 10 km/h (6.2 mph) due to bouncing on rough ground and reduced pickup performance at higher speeds. Maximum instantaneous feedrates in excess of 20 t/h (22 ton/h) were measured in heavy uniform affaffa windrows. Feeding was aggressive in all crops.

The New Holland 320 was capable of producing firm, well-formed bales. Length of the 356 x 457 mm (14 x 18 in) bales could be adjusted from 305 to 1320 mm (12 to 52 in). Bale length variation, at the 1000 mm (39 in) length setting was about 115 mm (4.5 in). For a certain length setting, longer bales were usually produced at higher feedrates. Average hay bales weighed from 28 to 35 kg (62 to 77 lb), while average straw bales weighed from 18 to 26 kg (40 to 57 lb). Bale density varied from 210 kg/m³ (13.1 lb/ft³) in heavy alfalfa to 106 kg/m³ (6.6 lb/ft³) in light straw.

The New Holland 320 was easy to operate. Most adjustments were convenient. Adjusting the feed tines and changing the pickup speed were both inconvenient. Knotter performance was satisfactory with most twines if the knotters were adjusted to the manufacturer's specifications. With some brands of synthetic twines the twine fingers had to be advanced slightly from the manufacturer's recommended setting. The optional synthetic twine billhooks had to be used when using synthetic twines.

Average power requirements were usually less than 30 kW (40 hp) but a 45 kW (60 hp) tractor was needed to overcome power take-off power fluctuations, and to provide sufficient power on hilly and soft fields.

Leaf loss was usually less than 4%, similar to that of off-er conventional square balers.

The New Holland 320 was safe to operate if the manufacturer's safety recommendations were closely followed and normal safety precautions were observed.

Several mechanical problems occurred during the test. The feed tines broke when rebaling broken bales. The optional hydraulic bale density control ram and linkages failed. One bale chute chain broke, the chain support brackets failed and the welds on the bale chute frame cracked.

RECOMMENDATIONS

It is recommended that the manufacturer consider:

1. Supplying synthetic twine billhooks as standard equipment.
2. Specifying lubrication requirements for the telescoping tine bar and pickup suspension grease fittings.
3. Modifications to improve the durability of the hydraulic bale density ram and accessories.

4. Modifications to improve the durability of the bale chute chain support brackets.

Chief Engineer: E. O. Nyborg

Senior Engineer: E. H. Wiens

Project Engineer: K. W. Drever

THE MANUFACTURER STATES THAT

With regard to recommendation number:

1. We believe more New Holland 320 balers in our total market use natural fiber twine than synthetic. In some conditions using 7200 foot natural fiber twine, we have reports of difficulty with the synthetic twine billhooks. Our twine sales indicate 7200 foot twine is becoming more popular and in addition we believe the monofilament plastic twine is becoming less popular. However, we will continue to follow this subject closely and if we were to see a reversal in these trends we could change to the plastic twine billhooks as standard equipment.
2. This oversight has been corrected in the latest edition of the operator's manual.
3. Corrective action is in progress and changes are anticipated to balers manufactured in the fall of 1979.
4. We have this item on our product improvement list. Consideration is being given to higher strength or heavier gauge steel for the chain support brackets. We have found that proper brake adjustment will significantly extend the life of these brackets.

GENERAL DESCRIPTION

The New Holland 320 is a pull type, 540 rpm, power take-off driven, automatic twine tie baler. A floating drum pickup delivers hay to the feed chamber, where it is fed into the 356 x 457 mm bale chamber by a telescoping tine bar. Hay is compacted and bales formed by a slicing plunger operating at 105 strokes/min.

The test machine was equipped with an optional hydraulic bale density control consisting of one hydraulic ram operated by a baler mounted pump and control.

FIGURE 1 shows the location of major components while detailed specifications are given in APPENDIX I.

SCOPE OF TEST

The New Holland 320 was operated in a variety of crops (TABLE 1) for 123 hours while producing 21,682 bales. It was evaluated for rate of work, quality of work, power consumption, ease of operation, ease of adjustment, operator safety and suitability of the operator's manual.

TABLE 1. Operating Conditions.

CROP	HOURS	NUMBER OF BALES	FIELD AREA (ha)
Alfalfa	38	6430	64
Alfalfa, Bromegrass	42	9175	55
Crested Wheatgrass	16	1260	29
Green Feed	1	129	2
Wheat Straw	25	4508	60
Oat Straw	1	180	2
TOTAL	123	21,682	212

RESULTS AND DISCUSSION

RATE OF WORK

Average feedrates varied from 4 t/h in light straw to 14 t/h in heavy alfalfa-brome. Average feedrate depended on windrow size and uniformity, crop condition, field surface, available tractor speeds and operator skill. Speeds were normally limited to about 10

km/h, due to bouncing on rough ground and poorer pickup performance at higher speeds.

In heavy, uniform alfalfa windrows, instantaneous feedrates of over 20 t/h were measured. These were peak values, representing maximum baler capacity, which could not be maintained continuously.

Feeding was aggressive in all crops.

QUALITY OF WORK

Bale Quality: The New Holland 320 was capable of producing firm, durable bales, with square ends, in most crops (FIGURE 2). Average hay bales weighed 28 to 35 kg while average straw bales weighed 18 to 26 kg. Average bale density varied from 210 kg/m³ in heavy alfalfa to 106 kg/m³ in light straw.

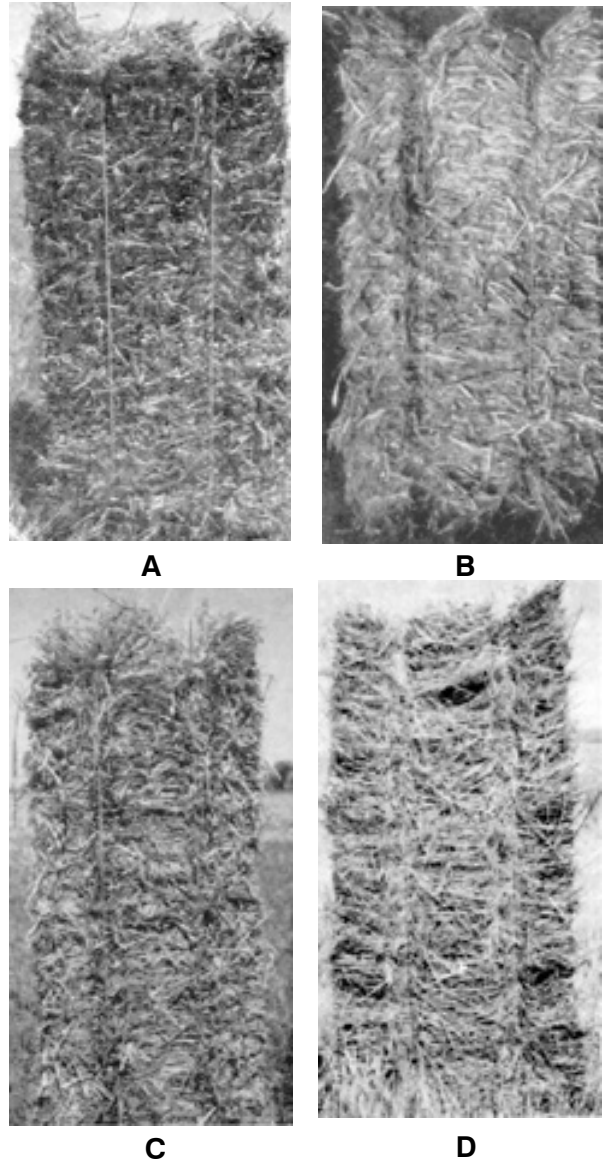

FIGURE 2. Typical Bales: (A) Alfalfa, (B) Straw, (C) Green Feed, (D) Crested Wheatgrass:

In very light crested wheatgrass windrows, the pressure bars had to be set well into the bale chamber to obtain suitable bale density. This sometimes caused bowed bales (FIGURE 3).

Bale Length Variation: As with most conventional square balers, it was difficult to obtain consistent bale length, especially in non-uniform windrows. Because of its high plunger speed, bale length variation, for the New Holland 320, usually was less than for balers

with lower plunger speeds. When set for 1000 mm length, bale lengths typically varied from 945 to 1060 mm.

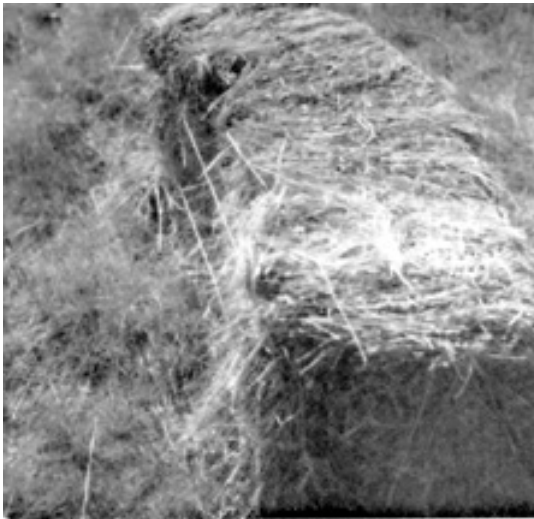

FIGURE 3. Bowed Bales Formed in Light Crested Wheatgrass Windrows.

Bale length is adjusted by positioning the metering arm stop (FIGURE 4). The metering wheel advances the metering arm with each plunger stroke. Bale length uniformity depends on a consistent number of plunger strokes to form each bale. If the metering arm trips at the beginning of the last plunger stroke, rather than at the end of the stroke, bale length is increased by the length of compressed hay delivered during the last plunger stroke. Uniform feedrates are therefore important in reducing bale length variation.

For the same length setting, higher feedrates usually produced longer bales. For example, in a uniform alfalfa field, average bale length was 1000 mm when baling at 5 t/h but increased to 1110 mm at 15 t/h. The same trend was evident in wheat straw with average bale length increasing from 950 mm at 3 t/h feedrate to 1020 mm at 15 t/h.

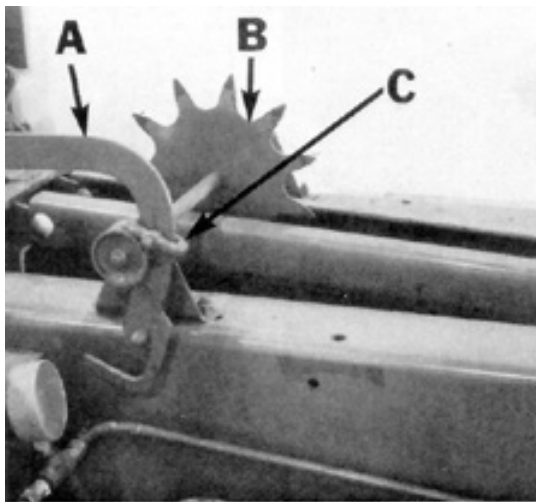

FIGURE 4. Bale Length Adjustment: (A) Metering Arm, (B) Metering Wheel, (C) Adjustable Stop.

Leaf Loss: As with most conventional square balers, leaf loss in dry hay was lower than with round balers. Total loss from the pickup and bale chamber was less than 4% in most field conditions. Pickup losses were normally insignificant unless ground speed was very high or windrows were light and poorly formed.

Knotter Reliability and Performance: The knotters, when properly adjusted, performed satisfactorily with most twines. Knotter adjustments were clearly outlined in the operator's manual. With some brands of synthetic twines, better tying performance was

obtained by advancing the twine fingers slightly from the manufacturer's recommended setting.

The New Holland 320 was supplied with sisal billhooks. With synthetic twines it was usually necessary to change to synthetic twine billhooks. Changing billhooks took one man, with tools, about 15 minutes. Since the synthetic twine billhooks performed well with most sisal twines, it is recommended that the manufacturer supply synthetic twine billhooks as standard equipment.

Knot strength was about 50% of twine tensile strength with synthetic twines and about 40% of twine tensile strength with sisal twines.

POWER CONSUMPTION

Power Take-off Requirements: FIGURE 5 shows typical instantaneous power take-off requirements for the New Holland 320. Power requirements fluctuated from 0 to 34 kW on each plunger stroke. Due to these wide power fluctuations, average power requirements were less than instantaneous requirements, varying from 6 to 25 kW, over a full range of feedrates. FIGURE 6 shows the average power take-off requirements at various feedrates in alfalfa and wheat straw.

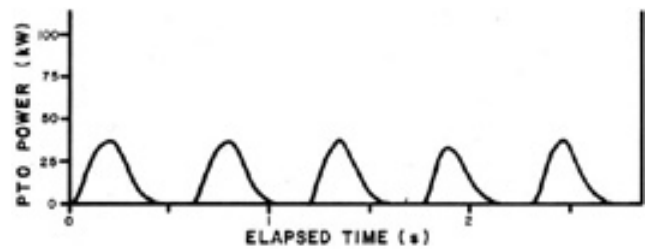

FIGURE 5. Instantaneous Power Take-off Requirements when Baling Alfalfa at 10 t/h Feedrate.

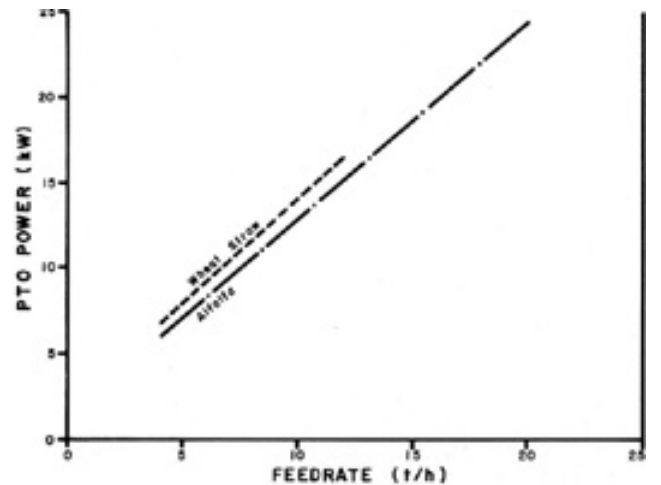

FIGURE 6. Average Power Take-off Requirements when Baling Alfalfa and Straw.

Tractor Size: The manufacturer recommended that a 3 plow (about 25 kW) or larger tractor be used. Average power take-off requirements were usually less than 25 kW and power required to pull the baler on level ground was usually less than 5 kW. A 45 kW tractor was, however, needed to fully utilize baler capacity in soft or hilly fields and to overcome the power fluctuations illustrated in FIGURE 5.

Specific Capacity: Specific capacity is a measure of how efficiently a machine performs a task. A high specific capacity indicates efficient energy use while low specific capacity indicates inefficient operation. The specific capacity of the New Holland 320 varied from 0.7 to 0.8 t/kWh in alfalfa and from 0.6 to 0.7 t/kWh in wheat straw. This compares to an average specific capacity of 0.5 t/kWh for large round balers in alfalfa. These values represent average conditions and not peak outputs.

EASE OF OPERATION

Hitching: The New Holland 320 was easily hitched to tractors equipped with a 540 rpm power take-off. The hitch jack was convenient for raising and lowering the hitch tongue. The power shaft pedestal and hitch clevis were adjustable to suit drawbar heights.

Transporting: The hitch tongue could be swung into transport or field position without getting off the tractor. Dismounting the tractor was necessary to fold the bale chute and to raise the pickup. The New Holland 320 could normally be placed into field or transport position in about two minutes.

The baler towed well behind a tractor or suitably sized truck.

Feeding: Feeding was aggressive and positive in all crops. The pickup was wide enough to accommodate most windrows with minimum trampling by the rear tractor tire. The hitch tongue had two field positions, which provided extra pickup offset for wide tractors. Pickup visibility was excellent from most tractors.

Maneuverability: The New Holland 320 was sufficiently maneuverable for efficient baling.

Twine Threading: Twine threading was convenient. The operator's manual gave a clear description of twine threading procedures and a twine threading diagram was provided on the twine box lid.

EASE OF ADJUSTMENT

Bale Length: Bale length was conveniently adjusted with a wrench. Bale length settings from 305 to 1320 mm were possible. Obtaining a consistent bale length was difficult, since bale lengths varied, depending on windrow uniformity and feedrate.

Bale Density: The optional hydraulic bale density control was easy to adjust, although it was necessary to dismount the tractor. The pressure gauge could only be read from the ground, with the baler running, requiring extreme caution. Setting the bale density for a specific crop was a trial and error procedure.

The bale density control had sufficient adjustment range to produce dense bales in most crops. Normally, twine knot strength was the only factor limiting bale density. In very light windrows, or in very slippery hay, additional bale wedges had to be installed in the bale chamber. In light crested wheatgrass windrows, excessive pressure bar squeeze sometimes caused bale bowing (FIGURE 3).

Feeding System: The New Holland 320 had three adjustments to obtain optimum bale shape. The left feed tines could be rotated, the left and centre feed tines could be moved on the telescoping tine bar or the feeder back could be positioned (FIGURE 7). Rotating the left tine bar was convenient, but moving tines on the telescoping tine bar was inconvenient since the bolts were difficult to reach. The feeder back was easily adjusted with wrenches.

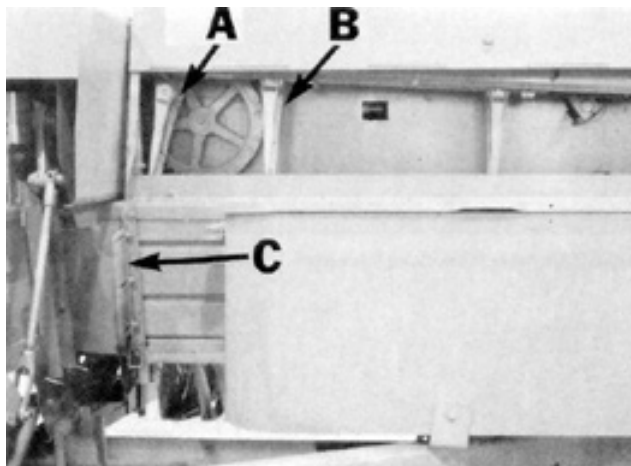

FIGURE 7. Feeder Adjustments: (A) Left Feed Tines, (B) Centre Feed Tines, (C) Feeder Back.

Pickup: Pickup height was set by positioning the pickup gauge wheel. Wrenches were required.

The operator's manual specified that the pickup flotation springs be adjusted so that there was 11 to 14 kg weight on the pickup gauge wheel. More weight was required since the pickup bounced excessively at this setting.

The pickup windguard was adjustable to suit windrow size. Wrenches were required.

The New Holland 320 was equipped with a two speed pickup. Pickup speed was set by changing the pickup drive sprocket. Changing the sprocket was inconvenient due to interference with the optional hydraulic bale density pump drive chain (FIGURE 8).

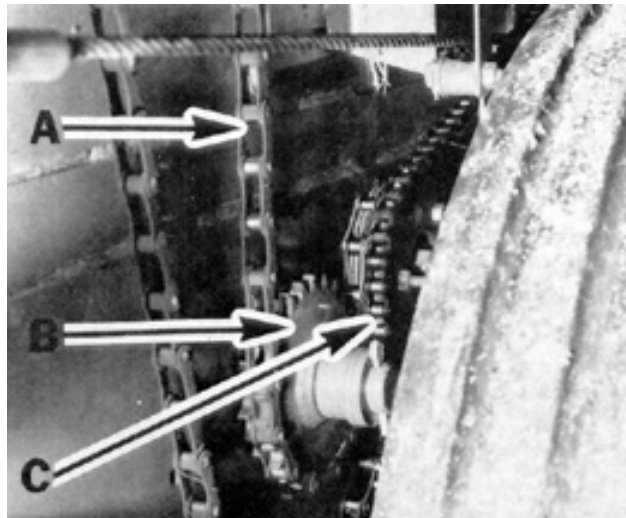

FIGURE 8. Interference Between the Pickup Drive Sprocket and Optional Hydraulic Bale Density Pump Drive Chains: (A) Pickup Drive Chain, (B) Pickup Drive Sprocket, (C) Pump Chain Drive.

The pickup drive was equipped with a slip clutch, which could be adjusted with a wrench.

Overload Devices: The drive shaft slip clutch slipped at each plunger stroke at normal feedrates when the slip clutch was adjusted to manufacturer's specifications. Clutch adjustment was critical since small changes in pressure plate spring length caused relatively large changes in slipping torque.

Replacing the flywheel or knotted shear bolts was convenient.

Bale Chute: The optional quarter turn bale chute was easily adjusted to place the bales on edge. The bale chute was reversible so bales could be dropped on either the left or right side.

Servicing: The New Holland 320 had seven chain drives, 42 grease fittings, one oiling location and two gearboxes. The operator's manual recommended daily chain oiling, lubrication of 34 grease fittings and one oiling location every 1000 bales, three grease fittings twice weekly, one grease fitting every 10,000 bales, servicing the gearboxes every 5000 bales and packing the wheel bearings annually. About 15 minutes were needed to service the New Holland 320. The flywheel slip clutch grease fitting was difficult to lubricate without removing the shield, but servicing was only required every 10,000 bales.

Tool Box: A tool box located on the left side of the baler was convenient for carrying tools, spare shear bolts or spare parts.

OPERATOR SAFETY

The New Holland 320 was safe to operate and service if normal safety precautions were observed. All moving parts, except for the flywheel were well shielded. As with most power take-off equipment, the power take-off must be disengaged and the tractor engine stopped before adjusting or servicing.

Caution had to be exercised when using the bale density pressure gauge, since the operator had to dismount the tractor, with the baler running, to read the gauge.

OPERATOR'S MANUAL

The operator's manual was clear, well written and well illustrated. It contained much useful information on operation, servicing,

adjustments and safety procedures. It did not include a lubrication schedule for the telescoping tine bar and pickup suspension grease fittings. It is recommended that lubrication requirements for these fittings be included.

DURABILITY RESULTS

TABLE 2 outlines the mechanical history of the New Holland 320 during 123 hours of field operation while baling 21,682 bales. The intent of the test was functional evaluation. The following failures represent only those which occurred during functional testing. An extended durability evaluation was not conducted.

TABLE 2. Mechanical History.

ITEM	OPERATING HOURS	EQUIVALENT BALES
PICKUP ASSEMBLY		
- The pickup gauge wheel bolt interfered with the pickup gauge tire. Washers were added to eliminate this at	Beginning of Test	
- The pickup flare bent and was straightened at	36	6350
FEED TINES		
- The feed tines broke when rebaling broken bales	Three times during the test	
PLUNGER		
- The plunger crank safety latch pivot pin was lost and replaced at	36	6350
- Plunger adjustments were checked, and the plunger readjusted to specifications at	46	8110
KNOTTER ASSEMBLY		
- The front twine box pressure plate, spring and adjusting bolt were lost and replaced at	54	9520
- The knotter knives were sharpened at	69, 114	12,160, 21,000
BALE DENSITY CONTROL		
- Bolts connecting the hydraulic bale density ram linkage to the compression rail were lost and replaced at	6	1060
- The cross piece on the hydraulic bale density ram linkage and the tension rods bent. The ram linkage was replaced and the rods straightened at	65	11,460
- The hydraulic ram housing broke and was welded at	93	16,390
BALE CHUTE		
- The bale chute chain broke and was repaired at	6	1060
- The bale chute chain support brackets were deformed at	9	1590
- One bracket broke at	108	19,040
- Welds on the bale chute frame cracked and were rewelded at	36	6350

DISCUSSION OF MECHANICAL PROBLEMS

FEED TINES

The feed tines (FIGURE 7) broke several times during the test when rebaling broken bales. Operating the baler at a reduced power take-off speed when rebaling broken bales reduced the occurrence of broken tines.

BALE DENSITY CONTROL

Ram Linkages: The cross piece on the hydraulic bale density ram linkage, the tension rail and the tension rods bent (FIGURE 9) when applying maximum hydraulic pressure. The cross piece was replaced with a heavier assembly supplied by the manufacturer and the rods and tension rail were straightened.

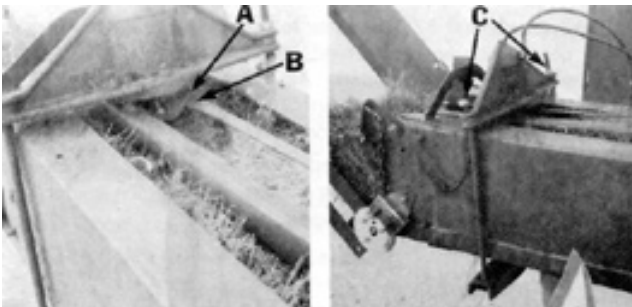

FIGURE 9. Bent Hydraulic Ram Linkages: (A) Cross Piece, (B) Tension Rail, (C) Tension Rod.

Hydraulic Ram Housing: After the hydraulic ram linkages were replaced, the casting on the hydraulic ram housing broke (FIGURE 10) and was welded. Modifications to improve the durability of the ram and linkage are recommended.

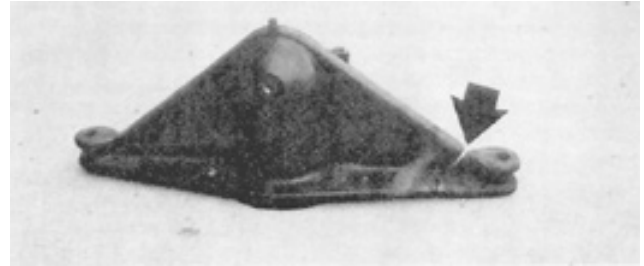

FIGURE 10. Broken Ram Housing.

BALE CHUTE

Chain Support Bracket: The bale chute chain support brackets were deformed (FIGURE 11) making removal and insertion of chain links difficult. One bracket eventually cracked (FIGURE 11). Modifications to improve the durability of the chain bracket are required.

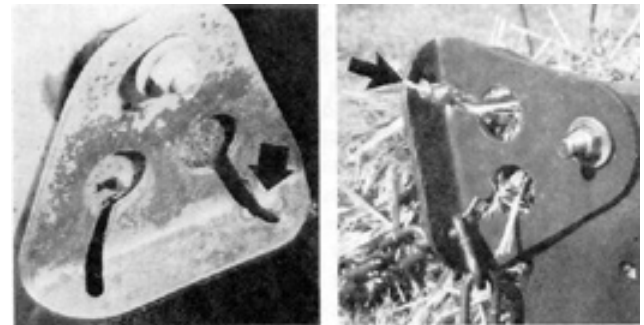

FIGURE 11. Deformed and Cracked Bale Chute Brackets.

Bale Chute Frame: Welds at the bottom of the bale chute frame cracked (FIGURE 12) at 36 hours. These were rewelded and no further problems developed.

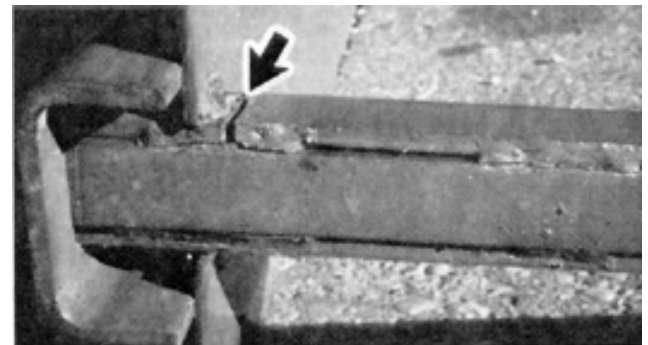

FIGURE 12. Failure of Bale Chute Frame Welds.

APPENDIX I

SPECIFICATIONS

MAKE: New Holland 540 rpm Power Take-off Baler

MODEL: Hayliner 320

SERIAL NUMBER: 461733

OVERALL DIMENSIONS:

- width 2895 mm
- length 6390 mm
- height 1480 mm
- ground clearance 285 mm

WEIGHTS: (field position)

- left wheel 540 kg
- right wheel 948 kg
- pickup gauge wheel 14 kg
- hitch 244 kg
- TOTAL** 1746 kg

TIRES:

- left 31 x 13.5, 15 NHS implement rib, 6 ply rating
- right 27 x 9.5, 15 NHS implement rib, 4 ply rating
- pickup gauge 12 x 3.00 semi pneumatic

PICKUP:

- type cam actuated drum pickup
- height adjustment pickup gauge wheel 1645 mm
- width 1645 mm
- number of tooth bars 6
- number of teeth 132
- tooth spacing 69 mm
- speed 80 and 105 rpm

FEEDING MECHANISM:

- type telescoping tine bar
- speed 105 strokes/min

PLUNGER:

- strokes per minute 105
- length of stroke 762 mm

BALE CHAMBER:

- width 457 mm
- height 356 mm
- range of bale lengths 305 to 1320 mm
- bale density control compression bars (primary) hay wedges (secondary)

TWINE CAPACITY:

- 6 balls

DRIVES:

- number of chain drives 7
- number of gear drives 2
- number of universal joints 3

SAFETY FEATURES:

- power take-off slip clutch
- flywheel shear bolt
- knottter drive shear bolt
- plunger safety stop
- pickup slip clutch

SERVICING:

- grease fittings 38
 - (every 1000 bales)
 - (twice weekly) 3
 - (every 10 000 bales) 1
- oil port (every 1 000 hales) 1
- chains (oil daily) 7
- gearbox 2
- wheel bearings 2

OPTIONAL EQUIPMENT:

- bale thrower
- synthetic twine billhook
- plunger face extension kit*
- wagon hitch and loading chute
- quarter turn bale chute*
- needle slot baffles
- bale case liner
- light kit
- pickup lift
- hydraulic bale density control*
- flotation tires*

* Supplied on test machine

APPENDIX II

MACHINE RATINGS

The following rating scale is used in PAMI Evaluation Reports:

- | | |
|---------------|--------------------|
| (a) excellent | (d) fair |
| (b) very good | (e) poor |
| (c) good | (f) unsatisfactory |

APPENDIX III

METRIC UNITS

In keeping with the Canadian metric conversion program, this report has been prepared in SI Units. For comparative purposes, the following conversions may be used.

- | | |
|---|---|
| 1 hectare (ha) | = 2.47 acres (ac) |
| 1 kilometre/hour (km/h) | = 0.62 miles/hour (mph) |
| 1 tonne (t) | = 2204.6 pounds (lb) |
| 1 tonne/hour (t/h) | = 1.10 ton/hour (ton/h) |
| 1 tonne/hectare (t/ha) | = 0.45 ton/acre (ton/ac) |
| 1000 millimetres (mm) = 1 metre (m) | = 39.37 inches (in) |
| 1 kilowatt (kW) | = 1.34 horsepower (hp) |
| 1 kilogram (kg) | = 2.20 pounds mass (lb) |
| 1 kilogram/cubic metre (kg/m ³) | = 0.06 pounds mass/cubic foot (lb/ft ³) |
| 1 tonne/kilowatt hour (t/kW*h) | = 0.82 tons/horsepower hour (ton/hp.h) |



**ALBERTA
FARM
MACHINERY
RESEARCH
CENTRE**

3000 College Drive South
Lethbridge, Alberta, Canada T1K 1L6
Telephone: (403) 329-1212
FAX: (403) 329-5562
<http://www.agric.gov.ab.ca/navigation/engineering/afmrc/index.html>

Prairie Agricultural Machinery Institute

Head Office: P.O. Box 1900, Humboldt, Saskatchewan, Canada S0K 2A0
Telephone: (306) 682-2555

Test Stations:	
P.O. Box 1060	P.O. Box 1150
Portage la Prairie, Manitoba, Canada R1N 3C5	Humboldt, Saskatchewan, Canada S0K 2A0
Telephone: (204) 239-5445	Telephone: (306) 682-5033
Fax: (204) 239-7124	Fax: (306) 682-5080