

Evaluation Report

530



VICON RP 1510 Round Baler (tested as Cereal Implements 560 Round Baler)

A Co-operative Program Between



ALBERTA
FARM
MACHINERY
RESEARCH
CENTRE



PRAIRIE AGRICULTURAL MACHINERY INSTITUTE

CEREAL VICON RP1510 560 ROUND BALER

MANUFACTURER:

Vicon, Inc.
Cambridge, Ontario
Canada

DISTRIBUTORS:

RP 1510
(Vicon Wheat-Belt)
6423-30th St. N.E.
Calgary, Alta.
T2C.1R9
(403) 279-2855

CI 560
(Cereal Implements)
Box 1420, 1000-6th Ave. N.E.
Portage la Prairie, Man.
R1N 3N9
(204) 239-5544

RETAIL PRICE: \$18,015 (March 1987, f.o.b. Portage la Prairie, Manitoba)

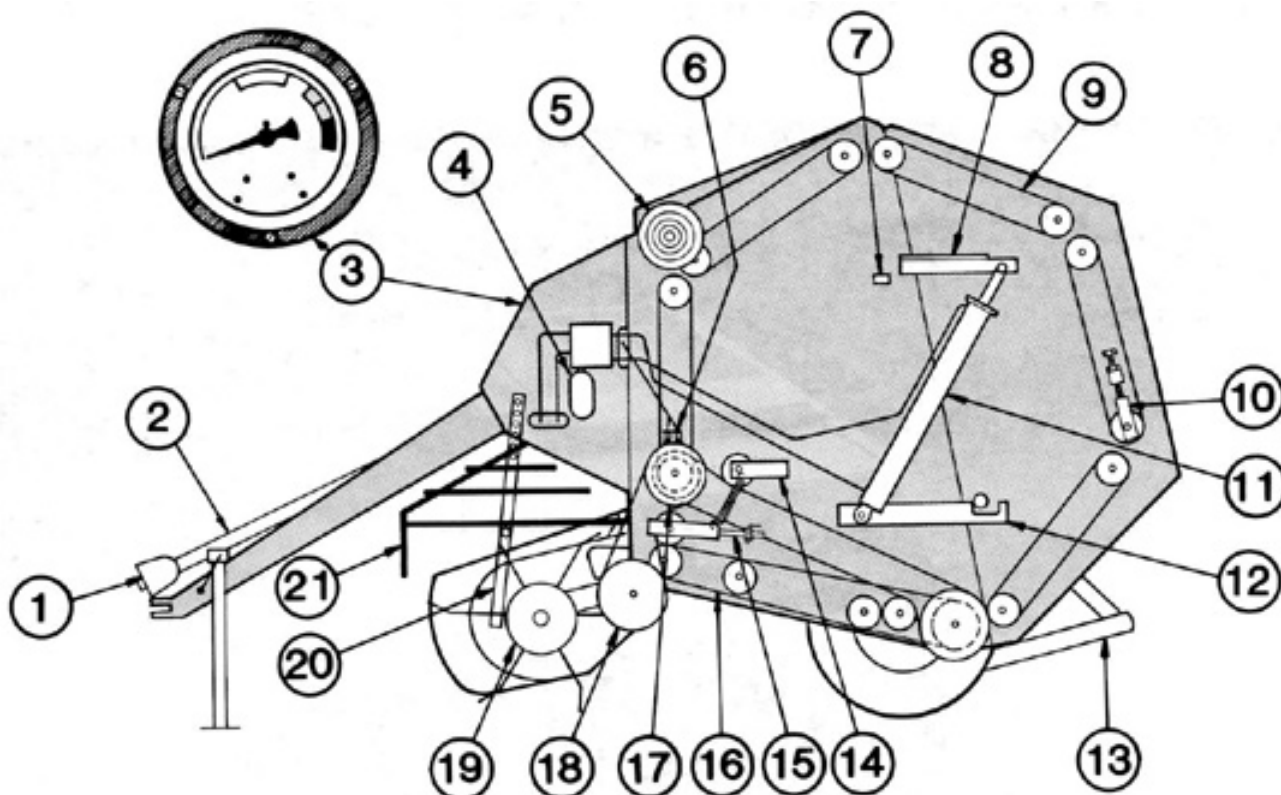

FIGURE 1. Vicon RP 1510/CI 560 Round Baler: (1) Constant Velocity PTO, (2) Drive Shaft, (3) Density Gauge, (4) Accumulator, (5) Twine Driving Wheel, (6) Automatic Chain Oiler Brushes, (7) Bale Counter, (8) Gate Lock, (9) Upper Forming Belts, (10) Adjusting Block, (11) Gate Cylinder, (12) Gate Latch, (13) Bale Kicker, (14) Chain Idler, (15) Belt Tensioner, (16) Platform Belts, (17) Main Drive Roller, (18) Pickup Pivot Shaft, (19) Pickup, (20) Transport Arm, (21) Pickup Guard.

SUMMARY

The performance of the Vicon RP 1510/CI 560 round baler was very good in most hay and straw crops. Damp hay or straw restricted feeding capabilities and caused plugging.

Rate of Work: Typical throughput of the Vicon RP 1510/CI 560 was 4.3 ton/h (3.9 t/h) in wheat straw and 8.4 ton/h (7.6 t/h) in alfalfa. Throughput was limited by pickup and feeding performance rather than by bale chamber capacity.

Bale Quality: Bale quality was very good, with well formed and durable bales in all crops. Hay bales weighed from 1100 to 1400 lb (499 to 635 kg) and straw bales from 800 to 1000 lb (363 to 454 kg).

Weatherability: Resistance to bale moisture penetration and spoilage was very good after 90 days of weathering.

Leaf Loss: Total leaf and stem loss was 4.5% in alfalfa at a moisture content of 15%. This was considered good.

Ease of Operation: Starting and forming the bale was easy with the Vicon in most crops. Preloading the hydraulic system was important for proper bale density control.

The electric twine wrapping system required little operator experience to tie a good bale. The bale density gauge cued the operator when to tie the bale. The operator was required to stop before starting the wrapping procedure. A bale kicker made backing unnecessary to clear the bale from under the gate. A bale could be wrapped and discharged in about 65 to 75 seconds.

Feeding was positive and aggressive in most crops, but plugging occurred frequently in greenfeed and occasionally in damp hay or straw. The distance between the end of the pickup and the beginning of the forming platform seemed to be the major cause for this problem. Overloading the bale chamber caused the drive shear pin to break, while overloading the pickup caused the drive belt to slip.

The Vicon was easy to maneuver and transport, but visibility to the rear was restricted.

Ease of Adjustment: Servicing, maintenance and routine adjustments were simple.

Power Requirements: Peak power requirements were about 47 hp (38 kW) in hay on firm level fields, A 70 hp (52 kW) tractor was suggested by the manufacturer to fully utilize baler capacity on soft and hilly fields.

Operator Safety: The Vicon was safe to operate if personal precautions were observed. One important precaution was shutting off the PTO when checking or servicing the twine box and tying mechanism. This was very important because the twine box and tying mechanism were located above the pickup.

Operator's Manual: The operator's manual was very well written and useful. Instructions for the windguard and pickup adjustment did not closely correspond with actual baler design.

Mechanical Problems: No serious mechanical problems occurred during the 167 hours of field test.

RECOMMENDATIONS:

It is recommended that the manufacturer consider:

1. Moving the pickup closer to the forming platform to improve feeding into the chamber.
2. Clarifying discrepancies between instructions in the operator's manual and baler design concerning windguard and pickup height adjustments for the CI 560 and concerning the pickup height adjustment for the Vicon RP 1510.
3. Modifications to the door fasteners on the safety shields to improve their convenience.
4. Modifications to the pickup safety guard to improve accessibility to the tying mechanism.
5. Modifications to the gate cylinder locks to improve access to the lock retainers.

Station Manager: G.M. Omichinski

Project Engineer: R.R. Hochstein

Project Assistant: R.W. Storzynsky

THE MANUFACTURER STATES THAT

With regard to recommendation:

1. The pick-up has been moved closer to the forming platform on 1987 and future production models. This significantly reduces the probability of plugging.
2. The operator's manual will be revised to clarify discrepancies. The windguard should rest above the finger bands to allow feeding of light crops. Its upward travel can be limited by installing bolts in the windguard slot. The pick-up height adjustment depends on tractor drawbar height and crop conditions. If available stop bolt locations are not acceptable, an additional hole could be drilled in the transport arms or the gauge wheel can be set to support a small amount of weight.
3. Larger round plastic knobs have been installed on 1987 and future production models.
4. Operator safety will be improved in future production with the installation of three steps on each side of the pick-up safety guard.
5. The lock retainers are easily accessed with the gate in a raised position. Proper procedure for their use would be:
 - i) Raise the gate;
 - ii) Shut off the tractor;
 - iii) Position the cylinder locks onto the cylinder rods;
 - iv) Lower the gate, without starting the tractor, onto the gate cylinder locks.

This method prevents the locks from jumping out of place which prevents twisting of the gate frame. The cylinder locks hold the gate open to a position which is optimum for the operator to perform belt maintenance on the top sets of belts from inside the bale chamber. The operator's manual will be revised to clarify proper use of the locks.

GENERAL DESCRIPTION

The Vicon RP 1510 is essentially the same as the Cereal/Implement 560 except for the twine box cover, setting of the windguard position and optional versus standard equipment. It is a pull-type power take-off driven baler with a cylindrical baling chamber and a floating drum pickup. The twine wrapping mechanism is automatic.

Material is fed into the 5.0 ft. (1.5 m) wide 6.0 ft. (1.8 m) diameter baling chamber by the pickup. The baling chamber is a fixed chamber type with five, 11 in (280 mm) wide platform belts and five sets of forming belts making up the circumference of the baler. Each set of belts is made up of five, 11 in (280 mm) wide belts. All belts rotate in a fixed location. As with all fixed chamber balers, the RP 1510 produces bales with a low density core, and a tight outside wrap.

Detailed specifications are given in APPENDIX I, while FIGURE 1 shows the location of major components.

The machine supplied to PAMI was a CI 560 equipped with the following: electric start automatic twine tie, bale kicker and automatic chain oiler. This equipment is optional on the Vicon RP 1510, but is standard on the CI 560.

SCOPE OF TEST

The RP 1510 baler was operated in a variety of crops (TABLE 1) for 167 hours, while producing 2055 bales. It was evaluated for rate of work, quality of work, power requirements, ease of operation, ease of adjustment, operator safety and suitability of the operator's manual.

TABLE 1. Operating Conditions

CROP	OPERATING HOURS	NUMBER OF BALES	EQUIVALENT FIELD AREA ac	(ha)
Alfalfa	97	1301	442	(179)
Alfalfa-Bromegrass	18	230	145	(59)
Alfalfa-Timothy	13	175	35	(14)
Slough grass	2	15	11	(5)
Oats Greenfeed	11	84	50	(20)
Wheat Straw	26	250	130	(53)
TOTAL	167	2055	813	(330)

RESULTS AND DISCUSSION

RATE OF WORK

Throughput depended on windrow size, uniformity of crop conditions, field surface, available tractor speeds and operator skill. Typical throughput for the RP 1510 (TABLE 2) was 4.3 ton/h (3.9 t/h) in wheat straw and 8.4 ton/h (7.6 t/h) in alfalfa. The values in Table 2 are all based on average workrates for daily field operation. Peak workrates during any one day were generally 10 to 20% higher.

In most crops, the feedrate was primarily limited by windrow size and pickup/feeding performance. In lighter crops, the ground speed was normally limited to about 7 mph (11 km/h) primarily due to pickup performance.

TABLE 2. Typical Throughputs

CROP	CROP YIELD ton/ac (t/ha)	DAILY AVERAGE THROUGHPUT ton/h (t/h)
Alfalfa	1.8 (4.0)	8.4 (7.6)
Alfalfa-Bromegrass	0.8 (1.8)	6.4 (5.8)
Alfalfa-Timothy	2.5 (5.6)	6.7 (6.1)
Oats Greenfeed	1.3 (2.9)	5.7 (5.2)
Wheat Straw	0.9 (2.0)	4.3 (3.9)

QUALITY OF WORK

Bale Quality: The RP 1510 produced firm, durable bales with flat ends and uniform diameter in all hay crops and straw crops (FIGURE 2). Handling the bales when transporting did not present a problem. The overall bale quality depended greatly on the operator experience. Failure of the operator to evenly feed both sides of the baler in light windrows resulted in barrel or cone-shaped bales.

A typical hay or straw bale averaged 5.0 ft. (1.5 m) in width and 6.0 ft. (1.8 m) in diameter. Bales usually settled to about 95% of their original height after 90 days. Average hay bales weighed from



FIGURE 2. Typical Hay Bale.

1100 to 1400 lb (500 to 635 kg) with average densities ranging from 7.8 to 9.9 lb/ft³ (126 to 160 kg/m³). Average straw bales weighed from 800 to 1000 lb (363 to 454 kg) with average densities from 5.7 to 7.1 lb/ft³ (92 to 115 kg/m³).

Bale Weathering: During a period of 90 days, over which a total rainfall was measured at 9.3 in (23.6 cm), moisture had penetrated to a maximum of 2 in (50 mm) in the area where another bale had been touching. Spoilage occurred to a depth of 1.0 in (25 mm) on top of the bale.

Leaf Loss: The RP 1510 was tested for leaf and stem loss in a light crop of alfalfa, which had been cut with a 22 ft. (6.7 m) swather and in which two swaths were raked together to form a single windrow. Average crop yield was about 0.8 ton/ac (0.7 t/ha). Total leaf and stem loss was 4.5% at a 15% moisture content, which was considered good.

The importance of baling at a high moisture content on losses can be noted in FIGURE 3. This figure represents an accumulation of previous data for several round balers showing the total measured material loss over a range of moisture contents, in fields of mixed alfalfa-crested wheatgrass and brome grass. Although the RP 1510 was tested in a different crop, its performance was better than that presented in the figure.

FIGURE 3 does not include relative effects of baling unconditioned or light windrows. Heavy, conditioned windrows were important to minimizing losses.

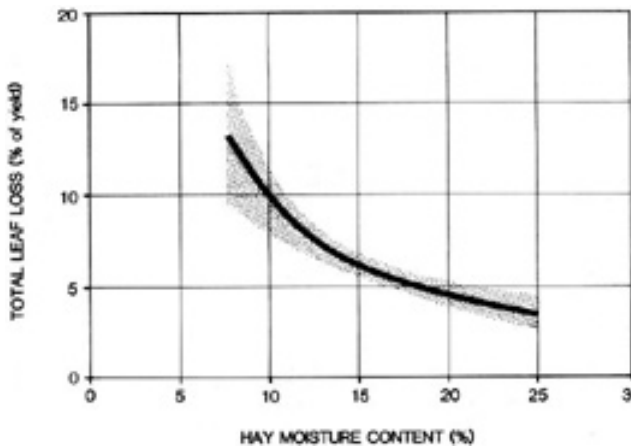

FIGURE 3. Leaf Loss in Mixed Alfalfa, Crested Wheatgrass and Bromegrass.

EASE OF OPERATION

Forming a Bale: It was easy to form a neat, durable bale in most crops. Feeding hay across the entire width of the bale chamber by weaving during bale core formations was not critical as the hay tumbled within the bale chamber, distributing itself quite evenly across the chamber. Some weaving during core formation did help the hay distribute across the chamber more easily.

Alternate side to side feeding to a count of at least 10 at each side was required during the later stages of the bale formation to produce bales of uniform diameter. Lack of visibility inside the bale chamber made it difficult for the operator to judge whether he was overfeeding one side or the other. This could result in barrel or cone-shaped bales.

An important step before starting the bale with the RP 1510 was to preload the hydraulic system. This was done by holding the tractor control valve open for a few seconds after the gate was closed and waiting for the indicator in the density gauge to reach the white zone (FIGURE 1). The control lever was then returned to neutral and the baling procedure could be continued. Failure to correctly carry out this procedure would result in poorly formed bales.

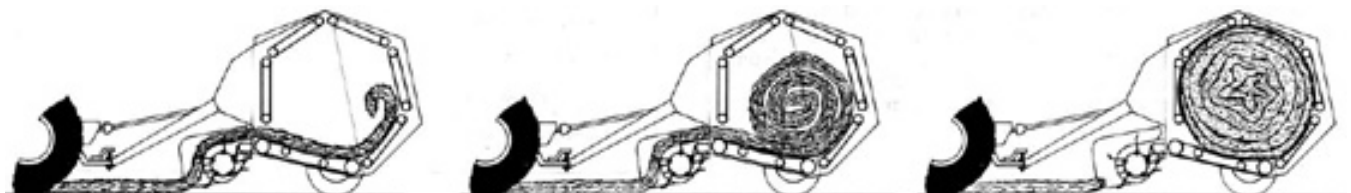

FIGURE 4. Stages of Bale Formation.

It was found that the best wrap was achieved if the operator geared down when the density gauge indicator reached the half-way mark in the green zone. The hay was thus fed in more slowly, allowing more time for the hay to be compressed before eventual tying of the bale. This resulted in a higher density wrapped bale to better resist weathering elements.

Wrapping the Twine: The twine wrapping on the RP 1510 was automatic. A bale density gauge on the right upper front of the baler cued the operator when to tie the bale.

To start wrapping, the operator pushed a button on the twine control panel, which activated the trip solenoid to drop the twine into the bale chamber. FIGURE 5 shows the twine tying mechanism.

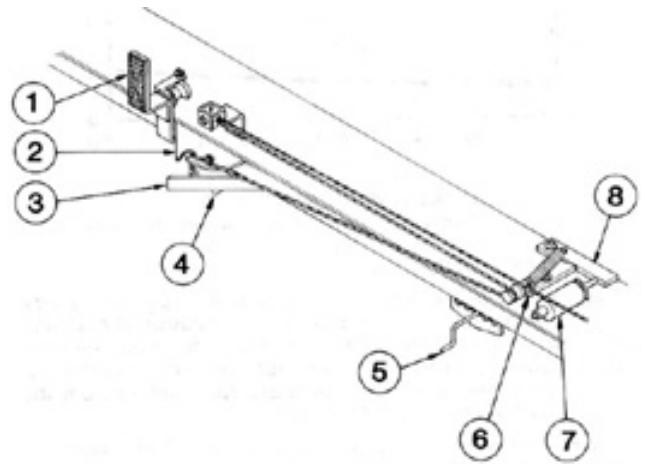

FIGURE 5. Twine Tying Mechanism: (1) Reflector, (2) Twine Guide, (3) Twine Holder, (4) Twine Knife, (5) Twine Adjustment Rod, (6) Twine Arm, (7) Solenoid, (8) Trip Lever.

When the twine was caught by the bale, it activated the twine driving wheel which in turn drove the twine guide. A reflector attached to the twine guide alerted the operator when the tying procedure had begun and its progress by lateral movement across the bale width. As the twine guide moved across the width of the baler, it automatically reset itself for the next bale. The twine was cut as it passed across the knife and twine holder. Little operator skill was required for this operation.

Occasionally the twine would not fall into the bale chamber. It was then necessary to stop the baler and manually feed the twine into the bale. Keeping the shield clean helped the twine slide into the chamber. A mis-tie of this nature would occur approximately once every 50 bales.

There are four different step pulley diameters on the driving wheel which are used to regulate the amount of twine on the bale. The smallest diameter applied 16 wraps or 300 ft (91 m) per bale and the largest diameter applied 38 wraps or 714 ft (218 m) per bale.

The tying sequence took 60 to 70 seconds for the 23 wrap setting which is typical for a baler with a single twine tube.

Discharging a Bale: Once the twine was cut the bale was ready for ejecting by simply opening the gate with the remote hydraulics. Slowing down the PTO prior to discharging is recommended to prevent any damage to the outside wrap of the bale. A bale kicker eliminated the need to back up before discharging the bale. The bale kicker rolled the bale away from under the gate, far enough so that the gate could be closed. The whole procedure of wrapping and discharging took 70 to 80 seconds.

Transporting: The R P 1510 was easy to maneuver and transport. Ground clearance was adequate and there was ample hitch clearance for turning sharp corners. The operator had to remember to place the jack into its storage position to prevent damage on turns.

Care was necessary when backing up or transporting on roadways due to obstructed visibility to the rear. The baler could be easily towed behind a tractor or suitably sized truck. Dismounting the tractor was required to lift the pickup. Placing the pickup in transport required an upward lift of only about 18 lb (80 N).

Hitching: The RP 1510 was easy to hitch to a tractor. The hitch-jack could be removed and placed into its storage position as soon as the base was clear of the ground. Full retractions of the jack was not required. The location of the jack near the hitch point, sometimes limited operation of the jack crank.

Feeding: Feeding was positive and aggressive in most crops. Plugging occurred frequently in greenfeed and occasionally in damp hay and straw. Plugging occurred due to bunching of material between the pickup and the forming platform section of the chamber. The pickup teeth had retracted at this point and the forming belts could not pull the material into the bale chamber (FIGURE 6). The operator had to stop the baler and remove the bunched material. This problem occurred mainly when the material was damp. It occurred frequently in greenfeed because of the high moisture content. It is recommended that the manufacturer consider moving the pickup closer to the forming chamber to shorten the distance between the pickup and the platform belts.



FIGURE 6. Material Caught Between Pickup and Forming Platform.

The plugging problem was slightly reduced when the windguard was placed into a lower position where it rested on the pickup guards. This preferred windguard position restricted the upward movement of the windguard, causing a more aggressive action on the material, since it compressed the feed material into the pickup teeth. The operator's manual for the CI 560 indicated two slotted guide positions for the windguard, however, only one was apparent on the baler. It is recommended that the manufacturer consider clarifying the discrepancy between adjusting instructions and baler design. There was no discrepancy regarding the RP 1510.

Twine Threading: Twine could be threaded without the use of a wire. The operator's manual was needed when first threading the twine. The twine tying system is unique and some familiarity was essential to properly thread the twine. The operator's manual had an excellent diagram showing the twine threading procedure.

The twine cutter performed very well. The blade broke and had to be replaced at approximately 155 hours.

The hinged door to the twine box was difficult to open on the CI 560 version of the round baler. It was necessary to reach across the top of the PTO to release the RHS latch. The handle for the door was located on the lower left corner of the door and made lifting difficult. The twine box door on the RP 1510, with only a single latch, was considerably easier to operate.

EASE OF ADJUSTMENT

Drive Chains: Spring loaded sprockets kept tensions on the main drive chain and the four roller drive chains. Chain tension was held constant. No adjustment to the springs was required during the 167 hour test.

Flat Belts: Belt tension was adjusted with six adjusting rollers, five rollers for the five sets of forming belts and one roller for the platform belts. Adjusting blocks located on both sides of the baler were used to reposition the adjusting rollers to achieve the required belt tension. Upper belts have correct tension when there is a 2.5 in (64 mm) clearance when pressing down on the belts

halfway between the rollers. Proper tension on the platform belts was achieved when the belts could be depressed up to 1 inch (25 mm) of the rear idler. Adjusting belt tension was not difficult but the operator had to be careful to adjust each set of adjusting blocks the exact same amount on either end of the roller. If this was not done the belts would not turn evenly and excessive wear on the belts would result. Belt tension was adjusted once during the test. Roller scrapers used to keep the rollers clear of buildup, moved with the rollers when belt tension was adjusted.

Pickup: The pickup operating height was set with a stop bolt to one of six positions on the transport arm. The operator's manual suggested setting the gauge wheel at 0.25 to 0.75 in (6 to 19 mm) below the pickup teeth and setting the stop bolt on the pickup transport arm for a gauge wheel clearance of 1 to 1.5 in (25 to 38 mm) off the ground. If the procedure suggested in the operator's manual was followed, the operating height was either too high or too low. It was necessary, on the test baler to use the gauge wheel to control the operating height since the adjustment positions on the transport arm were not adequate. It is recommended that the manufacturer consider clarifying the discrepancy between the operator's manual and baler design involving the pickup height adjustment.

Pickup floatation was provided by an adjustable floatation spring, which required no further adjustment after the initial setting.

The pickup drive chain was adjusted by moving a tightener against the chain to place a slight load on the chain. This was easily accomplished. The pickup pivot shaft which drives the pickup drive chain is driven from the main drive roller. This V-belt slipped when the baler was overloaded. Tension was adjusted with a belt idler pulley. This operation could be performed in a few minutes.

Wrap Settings: The driving wheel at the left side of the chamber has four different sized step diameters, which provided four different wrap settings. The largest diameter provided the greatest number of wraps and took the longest to tie. Setting the wrap was very simple and took very little time. There were two-twine tensioners on the RP 1510. One tensioner provided back-pressure on the twine so it will grip the wheel and the other was used to keep the twine tight on the twine wrapping mechanism. These were very simple to adjust. Twine adjustment rods were used to set how close the twine came to the edge of the bale. The left one was easy to reach but the rod on the right side of the machine was more difficult to reach.

Servicing: The RP 1510 used an automatic oil dispensing system for lubricating the drive chains. Oil was applied to the chains upon opening of the gate. This system used about 1 L per 100 bales. There was a total of 7 grease fittings and one gearbox. The operator's manual recommended changing the gearbox oil after the first 20 hours and then annually. The wheel bearings were to be repacked every 500 hours of operation. Opening and closing the hinged shields was inconvenient due to the type of fasteners used. They were easily damaged and bent and became very difficult to twist when locking the shields shut. It is recommended that the manufacturer consider modifying the door fasteners on the safety shields to improve their convenience. Complete daily servicing took 15 minutes.

POWER CONSUMPTION

Power Requirements: FIGURE 7 shows the power take-off and drawbar power requirements for the RP 1510. The power input is plotted against bale weight to show the power requirements while a bale is formed. Power take-off requirements varied from 4.0 hp (3.0 kW) at no load to a maximum of 43 hp (32.5 kW) in alfalfa. Drawbar requirements at 6.6 mph (10.6 km/h) on flat firm fields were about 4.0 hp (3.0 kW) when the bale reached maximum size. Although maximum horsepower requirements did not exceed 47 hp (35 kW) additional power was needed to suit field conditions, especially in soft hilly fields. The manufacturer suggested a 70 hp (52 kW) tractor to fully utilize baler capacity.

Specific Capacity: Specific capacity is a measure of how efficiently a machine performs a task. A large specific capacity indicates efficient energy use. The specific capacity of the RP 1510 was about 0.50 ton/hp-h (0.61 t/kW-h) in alfalfa at the instantaneous workrate of 10 ton/h (9.1 t/h). This specific capacity was greatly influenced by the workrate. This compares to an average specific capacity of 0.6 to 1.2 ton/hp-h (0.7 to 1.4 t/kW-h) for small square balers in alfalfa.

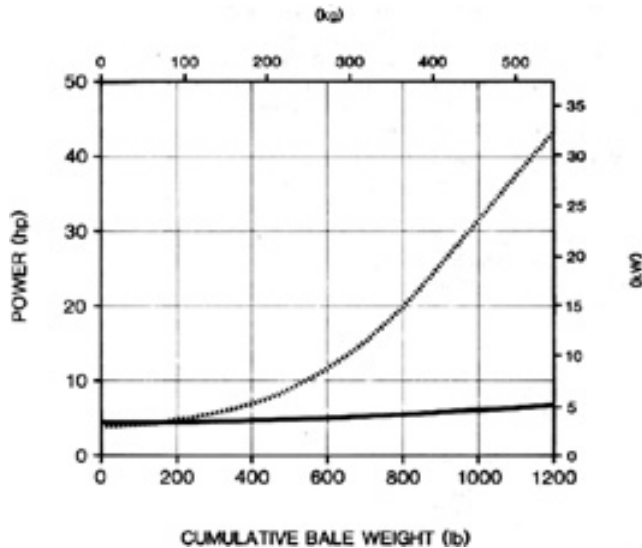

FIGURE 7. Power Consumption During Bale Formation in Alfalfa Bromegrass.

OPERATOR SAFETY:

The operator is cautioned that a round baler is potentially very dangerous. The operator must disengage the power take-off and stop the tractor engine to clear blockages or make adjustments. Many serious or fatal accidents have occurred with round balers. Most of these are caused by operators dismounting from the tractor while leaving the baler running.

The RP 1510 was safe to operate and service as long as common sense was used and the manufacturer's safety recommendations were followed.

The operator's manual and machine decals were adequate towards cautioning the operator to stop the baler and tractor when servicing the baler. All safety shields were conveniently hinged.

The twine box, the twine tying mechanism and the twine adjustment rods were all located above the pickup of the RP 1510. Servicing the tying mechanism (FIGURE 5) required the operator to stand on the pickup safety guard. Steps were provided on the pickup guard only on the left side. When adjusting the right adjustment rod of the tying mechanism the operator had to straddle the PTO to reach it from the steps. In addition, it was noted that the next highest safety guard was often used as a step. It is recommended that the manufacturer consider modifying the pickup by providing steps on both sides and on the next highest guards.

The RP 1510 had rear gate cylinder locks to permit safe servicing with the rear gate open. Access to the gate lock was inconvenient and difficult to reach when the gate was opened.

It is recommended that the manufacturer consider modifying the gate cylinder locks to permit greater access for servicing and improving the accessibility of the locks. Easy access to the locks encourages operators to regularly use them.

A slow moving vehicle sign was not provided with the baler, though there was a mounting bracket at the rear of the baler.

MECHANICAL HISTORY

The RP 1510 was operated for 167 hours while baling 2055 bales. The intent of the test was an evaluation of functional performance and an extended durability evaluation was not conducted.

The end of one of the hydraulic lines began to leak and had to be repaired at approximately 30 working hours.

OPERATOR'S MANUAL

In general, the operator's manual was very well written and contained much useful information on operation, servicing, adjustments and safety procedures. However, there were some discrepancies between baler design and adjustment instructions for the windguard and pickup for the CI 560 and pickup for the Vicon RP 1510.

APPENDIX I

SPECIFICATIONS

MAKE: Vicon/Cereal Implements
MODEL: RP1510/560
SERIAL NUMBER: 7000600121 (Cereal Implements 560 on test)
MANUFACTURER: Vicon, Inc. Cambridge, Ontario, Canada

DIMENSIONS:

- width 8.0 ft (2.4 m)
 - height 8.0 ft (2.4 m)
 - length 14.3 ft (4.4 m)
 - ground clearance 9 in (230 mm)

TIRES:

- undercarriage two, 11 L x 15 SL
 - pickup gauge 4.80/4.00-8

WEIGHT:

- left wheel 1869 lb (848 kg)
 - right wheel 1975 lb (896 kg)
 - hitch point 728 lb (330 kg)
 - Total: 4572 lb (2074 kg)

BALE CHAMBER:

- width 5.0 ft (1.5 m)
 - maximum diameter 6.0 ft (1.8 m)
 - bale density control hydraulic oil pressure
 - bale peripheral speed (at 540 rpm) 4.8 mph (7.7 km/h)

PICKUP:

- type fully floating cylindrical drum with spring teeth
 - height adjustment transport bar with stop rest settings
 - width 5.6 ft (1.7 m)
 - diameter 15 in (380 mm)
 - no. of tooth bars six, 22 teeth per bar
 - tooth spacing 3 in (76 mm)
 - speed (at 540 rpm) 75 rpm
 - tooth tip speed (at 540 rpm) 6.0 mph (9.7 km/h)

TWINE SYSTEM:

- capacity 5 balls
 - type electric start tying mechanism
 - recommended twine sisal or plastic
 - twine feed electric release into bale chamber
 - twine cutter twine holder

DRIVES:

- number of belt drives one
 - number of chain drives five
 - number of gear drives one
 - number of universal joints two
 - number of constant velocity joints one

BALE CHAMBER PLATFORM:

- number of belts 5
 - belt width 11 in (280 mm)
 - thickness 3/16 in (5 mm)
 - spacing, (centre to centre) 11-3/4 in (298 mm)
 - belt speed (at 540 rpm) 420 ft/min (128 m/min)
 - number of rollers 4
 - roller length 4.9 ft (1.5 m)
 - roller diameter one, 7-1/2 in (190 mm)
 three, 4-1/4 in (114 mm)
 - roller surface smooth steel
 - roller speed (drive) 410 rpm

FORMING SECTIONS:

- number of sections 5
 - number of belts per section 5
 - belt width 11 in (280 mm)
 - thickness 3/16 in (5 mm)
 - spacing (centre to centre) 11-3/4 in (298 mm)
 - belt speed (at 540 rpm) 420 ft/min (128 m/min)
 - number of rollers per section 2
 - roller diameter 4.5 in (114 mm)
 - roller speed (at 540 rpm) 350 rpm

SAFETY DEVICES:

- main drive shearbolt
 - rear gate cylinder locks
 - hinged safety shields

SERVICING:

- grease fittings
- chains
- gear box

seven
five, automatic oiler
one, change oil after 20 hours,
annually after that
two, hand pack every 500 hours

TRACTOR HOOK-UP

- connections
- hitch height

double action hydraulic hose, electrical
connection for tying mechanism
15 to 17 in (381 to 432 mm)

APPENDIX II**MACHINE RATINGS**

The following rating scale is used in PAMI Evaluation Reports:

Excellent	Fair
Very Good	Poor
Good	Unsatisfactory

SUMMARY CHART**VICON RP 1510/CEREAL IMPLEMENTS 560 ROUND BALER**

RETAIL PRICE: \$18,015 (January 1987, f.o.b. Portage la Prairie, MB)

WORK RATE: straw 4.3 ton/h (3.9 t/h)
alfalfa 8.4 ton/h (7.6 t/h)

QUALITY OF WORK:

Bale Quality	Very Good , soft core, tight outside wrap
Weatherability	Very Good , about 1 in (25 mm) spoilage
Leaf Loss	4.5% in alfalfa hay

POWER REQUIREMENTS:

Tractorsize	70 hp (52 kW) tractor has sufficient reserve for most field conditions
Specific Capacity	0.50 ton/hp-h (0.51 t/kW-h), improved by adjusting windguard to rest on pickup guards.

EASE OF OPERATION:

Forming a bale	Very Good , limited visibility in the chamber for uniform bales
Wrapping the twine	Very Good , a bit slow
Discharging the bale	Excellent , bale kicker
Transporting	Very Good , limited visibility
Hitching	Very Good , jack was obstructed in some cases
Feeding	Good , plugging occurred in damp crops

EASE OF ADJUSTMENT:

Drive chains	Excellent , self tensioning and auto oiled
Flat Belts	Very Good , time required to match both sides of adjusting rollers.
Wrap Settings	Very Good , 4 different settings
Pickup Servicing	Good , 15 min. for daily service, poor fasteners were difficult to open and close.

OPERATOR SAFETY: Well shielded, but care had to be taken around the front of the baler.

OPERATOR'S MANUAL: **Very Good**, well written

MECHANICAL HISTORY: One hydraulic line needed repairs



**ALBERTA
FARM
MACHINERY
RESEARCH
CENTRE**

3000 College Drive South
Lethbridge, Alberta, Canada T1K 1L6
Telephone: (403) 329-1212
FAX: (403) 329-5562
<http://www.agric.gov.ab.ca/navigation/engineering/afmrc/index.html>

Prairie Agricultural Machinery Institute

Head Office: P.O. Box 1900, Humboldt, Saskatchewan, Canada S0K 2A0
Telephone: (306) 682-2555

Test Stations:	
P.O. Box 1060	P.O. Box 1150
Portage la Prairie, Manitoba, Canada R1N 3C5	Humboldt, Saskatchewan, Canada S0K 2A0
Telephone: (204) 239-5445	Telephone: (306) 682-5033
Fax: (204) 239-7124	Fax: (306) 682-5080