

Evaluation Report 17



John Deere Model 500 Round Baler

A Co-operative Program Between



John Deere Model 500 Round Baler

Manufacturer:

John Deere Ottumwa Works
 Ottumwa, Iowa 52501
 U.S.A.

Distributor:

John Deere Limited
 455 Park Street
 Regina, Saskatchewan, Canada
 S4P 3L8

Retail Price:

\$6392.00 (May, 1977, f.o.b. Humboldt)

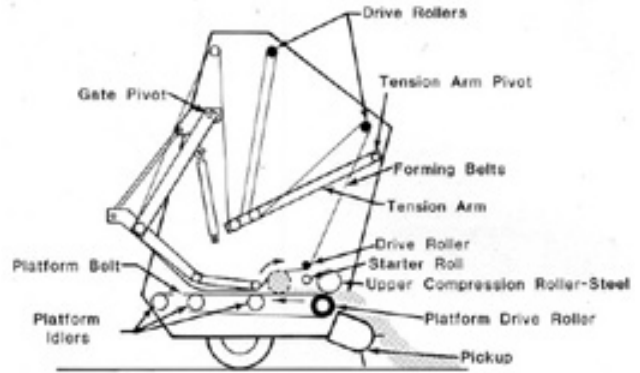

Figure 1. Schematic View of John Deere 500 Round Baler.

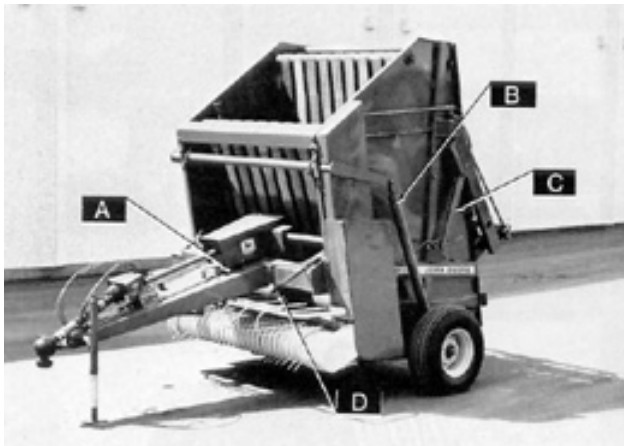

Figure 2. Front View of John Deere 500 Round Baler. Identification of Components: (A) Twine Cylinder, (B) Tension Spring, (C) Gate Cylinder, (D) Pickup Transport Lever.

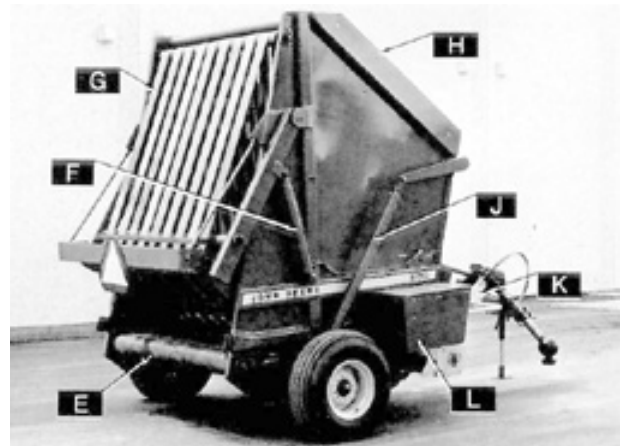

Figure 3. Rear View of John Deere 500 Round Baler. Identification of Components: (E) Platform Belt, (F) Gate Cylinder, (G) Forming Belts, (H) Forming Belt Drive Chain Shield, (J) Tension Spring, (K) Twine Cutter, (L) Twine Box.

Summary and Conclusions

Overall functional performance of the John Deere 500 round baler was *very good* but was reduced by feeding problems in long, coarse-stemmed crops. Ease of operation and adjustment both were *good*. Operation of the twine wrapping mechanism was *good*.

Average field speeds varied from 7 to 10 km/h (4.3 to 6.2 mph) while average throughputs varied from 5.5 to 12.3 t/h (6.1 to 13.5 ton/h). Ground speed was usually limited by pickup loss and not by baler capacity. Feeding was aggressive in all crops but was severely reduced in long, coarse-stemmed sweet clover due to unsatisfactory compression roller feeding.

Bales were well formed and neat in appearance. The John Deere 500 produced bales with an average length of 1.6 m (63

in) and an average diameter of 1.7 m (68 in). Hay bales weighed from 770 to 880 kg (1700 to 1940 lb) with an average density of 220 kg/m³ (13.7 lb/ft³).

Peak power take-off requirements were about 22 kW (29 hp) in hay and 20 kW (27 hp) in straw.

Leaf loss was comparable to that of other large round balers. In heavy windrows, at optimum moisture content, bale chamber loss was less than 5% while in light, dry alfalfa, average bale chamber loss was 15% and pickup loss was 7%. Heavy windrows, proper conditioning and baling at the maximum permissible moisture content all were important in reducing bale chamber loss.

The John Deere 500 was safe to operate if the manufacturer's safety recommendations were closely followed.

Recommendations

It is recommended that the manufacturer consider:

1. Modifications to improve feeding aggressiveness in long, coarse-stemmed crops.
2. Modifying the chain drive to the bale forming belts to eliminate the need for frequent tightening caused by interference of the drive chain and shield.
3. Modifying the twine route to reduce complications in threading.
4. Modifications to permit the baler to be used on tractors with drawbar heights greater than 380 mm (15 in).
5. Modifying the baler hitch to eliminate the need for the equal angle hitch attachment.
6. Recommending in the operator's manual that a fire extinguisher be mounted on the baler or tractor.

Chief Engineer -- E.O. Nyborg

Senior Engineer -- L.G. Smith

Project Technologist -- D.H. Kelly

The Manufacturer States That

With regard to recommendation number:

1. Modifications to improve feeding are being incorporated on all Model 500 balers by a field modification program as outlined below.
- 2 & 3. We will investigate these recommendations.
4. Pickup modifications to permit the baler to be used on tractors with greater drawbar heights are being incorporated on all Model 500 balers by a field modification program as outlined below.
5. The equal angle hitch is used on many power take-off driven machines manufactured by John Deere. The equal angle hitch allows power take-off machines to be operated at rated speed and load without imposing severe loads on the machine drive line and tractor transmission, even during sharp turns. The longer 560 mm (22 in) distance from the end of the tractor pto shaft to the hitch pivot makes possible longer telescoping pto hookups which do not bottom-out or separate during sharp turns or when operating over rough terrain. This also maintains equal universal joint angles and, as a result, reduces power take-off shaft vibration and noise.
6. A statement to this effect will be considered for insertion in operator's manuals prepared for new models of round balers.

General Description

The John Deere model 500 is a pull-type, power take-off driven baler with a cylindrical baling chamber and a floating drum pickup. The twine wrapping mechanism is hydraulically actuated.

Hay is fed to the baling chamber between two compression rollers. The upper roller is steel while the surface of the lower roller is covered with the platform belt. The baling chamber consists of a 1.52 m (60 in) wide platform belt on the bottom and nine 101 mm (4 in) wide forming belts on top. The platform belt is fixed while the forming belts are spring loaded to position themselves around the bale during formation.

Detailed specifications are given in Appendix I while Figures 1 to 3 show the location of major components.

Scope of Test

The John Deere 500 was operated at 540 rpm with a Case 1070 tractor in the conditions show in Table 1 for 106 hours while baling about 375 ha (929 ac). It was evaluated for rate of

Manufacturer's additional comments are as follows:

This report presents information gained during field evaluation tests with a John Deere 500 round baler. Since the conclusion of the tests, all John Deere Model 500 balers, including the test baler, have been modified by the manufacturer. The Model 500 is no longer in production, and has been replaced by the John Deere Model 510 round baler which produces a bale similar in size and weight to the Model 500, however, the bale forming components on the Model 510 are simpler and more easily serviced than on the Model 500 and the new Model 510 incorporates all the changes made in the Model 500 modification program. Figure 4 illustrates the modified Model 500.

The field modifications performed on the Model 500 are as follows:

- (a) **Safety:** Additional shielding is added to the front of the baler to discourage entry by the operator into the area of the compression rolls. Additional warning decals are placed on the machine to further emphasize the importance of safe operating practices.
- (b) **Pickup Performance:** The modification includes several changes to improve pickup performance. The pickup has been lowered by 40 mm (1.6 in) by relocating the baler wheel spindles. Reducing the pickup height will allow better pickup performance when operating with tractors with drawbar heights exceeding 380 mm (15 in). The reduced pickup angle provides better feeding and improved pickup flotation. Stronger pickup teeth and a modification to the tine pattern causes the teeth to move the hay closer to the compression rolls for better feeding.
- (c) **Feeding:** Feeding is improved by the modifications to the pickup noted above. In addition, the steel upper compression roll is replaced by a rubber-covered roll to gain more effective feeding.

As a result of these modifications, specifications for the modified Model 500 (Appendix I) change as follow:

Overall Dimensions	Test Baler	Modified Baler
Ground Clearance	260 mm (10.2 in)	193 mm (7.6 in)
Height	2840 mm (111.8 in)	2774 mm (109.2 in)
Compression Rollers		
Roller Surface	Upper-Steel	Upper-Rubber
Diameter	Upper-203 mm (8.0 in)	Upper-213 mm (8.4 in)
Front Forming Belt Drive Roller		
Roller Surface	Knurled	Rubber

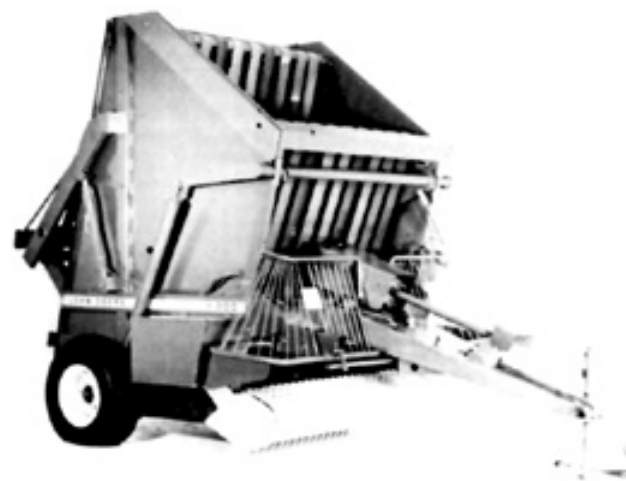

Figure 4. John Deere 500 After Field Modifications.

work, quality of work, power consumption, ease of operation, ease of adjustment, operator safety and suitability of the operator's manual.

Results and Discussion

RATE OF WORK

Average throughputs for the John Deere 500 (Table 1) varied from 5.5 t/h (6.1 ton/h) in rye straw to 12.3 t/h (13.5 ton/h) in flax straw that had been cut with a 9 100 mm (30 ft) windrower. In heavy, uniform alfalfa, continuous workrates of about 13 t/h (14 ton/h) were possible and a bale could be formed in about three minutes. In addition, it took about one minute to wrap the bale with twine and eject it.

In most crops, the maximum workrate was limited by pickup performance and not by bale chamber capacity. Pickup

Table 1. Operating Conditions

Crop	Crop Yield Range t/ha ton/ac	Hours	Average Speed km/h (mph)	Area Baled ha (ac)	Average Throughput t/h (ton/h)
Alfalfa, Brome-grass & Crested Wheatgrass	1.0 to 4.0 (0.4 to 1.8)	56.0	8.0 (5.0)	215 (530)	8.5 (9.4)
Alfalfa	0.5 to 5.0 (1.2 to 2.0)	18.5	9.0 (5.6)	47 (116)	10.6 (11.7)
Sweet Clover	3.0 to 4.0 (1.3 to 1.7)	18.5	7.0 (4.3)	49 (122)	9.0 (9.9)
Wheat Straw	1.0 to 2.0 (0.4 to 0.9)	10.5	8.8 (5.4)	50 (125)	7.0 (7.7)
Rye Straw	1.5 (0.7)	1.5	10.0 (6.3)	5 (13)	5.5 (6.1)
Flax Straw	1.3 (0.6)	1.0	10.0 (6.2)	9 (23)	12.3 (13.5)
TOTAL		106.0		375 (929)	

loss usually limited ground speed to a range of 8 to 10 km/h (5 to 6 mph). A heavy windrow was desirable to fully utilize baler capacity.

Feeding was aggressive in all crops except in long, coarse-stemmed sweet clover where capacity was reduced by feeding problems and plugging at the compression rolls limiting the throughput to about 4 t/h (4.5 ton/h), or less.

QUALITY OF WORK

Bale Quality: The John Deere 500 produced firm, durable bales (Figure 5) with flat ends and uniform diameter. Bales averaged 1.6 m (63 in) in length and 1.7 m (68 in) in diameter. Average hay bales weighed from 771 to 880 kg (1700 to 1940 lb) with an average density of 220 kg/m³ (13.7 lb/ft³). Density was uniform throughout the bale.

Leaf Loss: Total leaf loss for the John Deere 500 varied from less than 5% in ideal windrows to 22% in light dry windrows.

In a field of 4.5 t/ha (2 ton/ac) alfalfa which had been cut

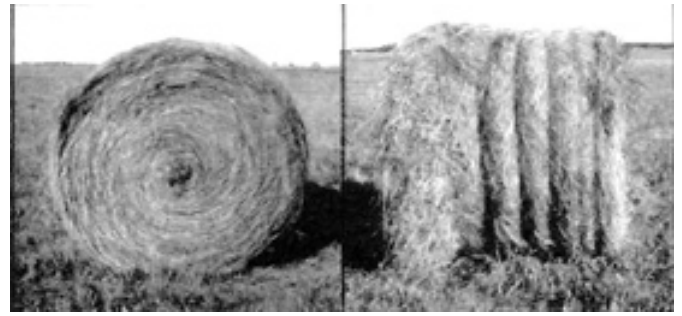

Figure 5. Typical Bales Formed by the John Deere 500.

with a 5500 mm (18 ft) windrower but which had not been conditioned, bale chamber losses were less than 5%. In this case, the windrow was heavy enough to fully utilize the capacity of the baler.

In another field of 1.2 t/ha (0.5 ton/ac) second cut alfalfa which had also been cut with a 5500 mm (18 ft) windrower, average pickup loss was 7% while average bale chamber loss was 15%. The hay had not been conditioned and due to drying conditions in late August, the stalks were at a moisture content which would just permit storage while the leaves were quite dry and brittle.

Bale chamber loss in a round baler depends on how long the bale is in the bale chamber. In the 1.2 t/ha (0.5 ton/ac) alfalfa crop it took about 15 minutes to form a bale while in the 4.5 t/ha (2 ton/ac) crop, a bale could be formed in about three minutes.

Research has shown that to minimize bale chamber losses with a round baler, windrows should be as heavy as possible, the hay should be conditioned to aid in stalk curing and moisture content should be at the maximum level which permits safe storage. Feedrate should also be as high as possible to minimize

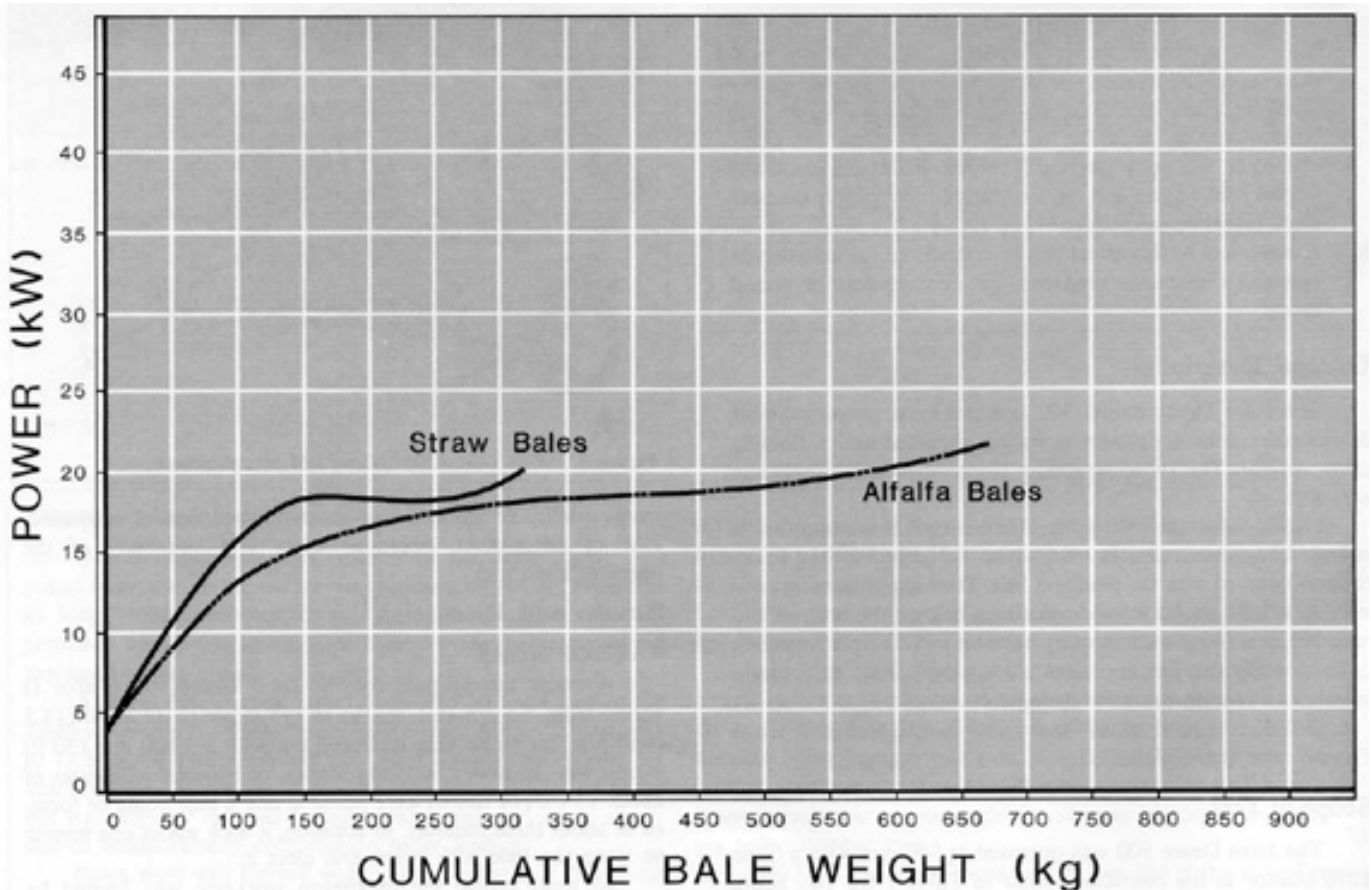

Figure 6. Power Consumption of the John Deere 500 During Bale Formation.

time in the baling chamber. It is often more economical to allow some pickup loss, by driving too fast, as the total loss level will be reduced due to decreased bale chamber loss. Under ideal conditions, bale chamber loss may be as low as 0.5%. Bale chamber losses in light crops can also be reduced by running the tractor at a lower power take-off speed and in a higher gear to maintain proper ground speed. This results in fewer turns to form a bale. Power take-off speed must however be fast enough for satisfactory pickup performance.

Loss characteristics of small square balers are quite different. For square balers, bale chamber losses vary from about 2 to 5% regardless of windrow size or moisture content. With a large round baler, losses depend on how long a bale stays in the baling chamber since the hay is in constant agitation while the bale is being formed.

POWER CONSUMPTION

Power Take-Off Requirements: Figure 6 shows the power take-off input for the John Deere 500 in alfalfa and in wheat straw. The power input is plotted against cumulative bale weight to show the power requirements as a bale is being formed. The power input varied from 4 kW (5 hp) at no load to a maximum of 22 kW (29 hp) in alfalfa and 20 kW (27 hp) in wheat straw for a fully formed bale.

Specific Capacity: Specific capacity is a measure of how efficiently a machine performs a task. A high specific capacity indicates efficient energy use while a low specific capacity indicates inefficient operation. The specific capacity of the John Deere 500 was about 0.67 t/kW.h (0.55 ton/hp.h) in alfalfa and 0.56 t/kW.h (0.46 ton/hp.h) in wheat straw. This compares to an average specific capacity of 0.98 to 1.45 t/kW.h (0.8 to 1.2 ton/hp.h) for small square balers in alfalfa. These values represent average operating speeds in average field conditions and not peak outputs.

EASE OF OPERATION

Forming a Bale: It was easy to form a neat, durable bale with the John Deere 500. Proper bale formation depended greatly on correct bale core formation. When starting a bale, it was necessary to weave the baler, back and forth across the windrow, so hay was fed evenly across the width of the baling chamber to form a uniform bale core. It was easiest to start a bale by reducing power take-off speed by about 25%. Once the bale core was formed, normal speed was resumed. A slight weaving action was also needed during bale formation to maintain a uniform diameter.

Figure 7 shows the position of the bale forming belts during bale formation.

Wrapping the Twine: A mechanical indicator at the front of the baler shows when a bale is full size and ready for twine

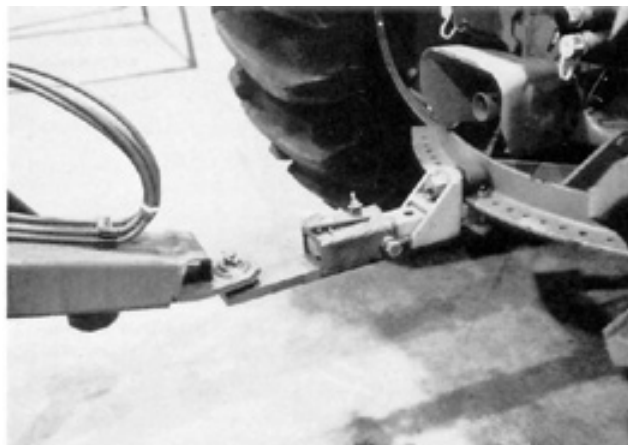

Figure 8. Equal Angle Hitch Attachment.

wrapping. The twine tube is controlled with the tractor hydraulic system.

To start wrapping, the twine tube is hydraulically moved to the left of the bale chamber. Once the twine has been caught by the hay entering the feed rolls and has made at least a full wrap around the left end of the bale, the hydraulic control is actuated to move the tube across the front of the bale chamber and the tractor forward travel is stopped but the power take-off is allowed to run. The return speed of the twine tube and subsequently, the number of twine wraps is determined by an adjustable flow control valve. When the twine tube reaches the right side, the hydraulic lever is momentarily released so there is at least one complete twine wrap around the right bale end. The lever is then actuated to move the twine tube further to the right against the twine cutting anvil.

Some problems occurred with twine catching on the twine cutter anvil and not wrapping properly. These problems were reduced by feeding the baler on the left side when beginning to wrap.

Twine consumption for the John Deere 500 was about 60 m/t (180 ft/ton). This compares to a twine consumption of about 225 m/t (670 ft/ton) for small square balers.

Discharging a Bale: Once the twine is cut, the power takeoff is shut off and the tractor and baler are backed up about 6 m (20 ft). The rear gate is hydraulically opened and the power take-off is engaged, with the tractor at idle, to eject the bale. The tractor and baler are then moved ahead about 4.5 m (15 ft) and the rear gate closed. A slight pressure is required on the gate hydraulic cylinders to ensure that the gate is fully closed. About one minute was needed to wrap and discharge a bale.

Transporting: The John Deere 500 was easy to maneuver and transport. Ground clearance was adequate and there was

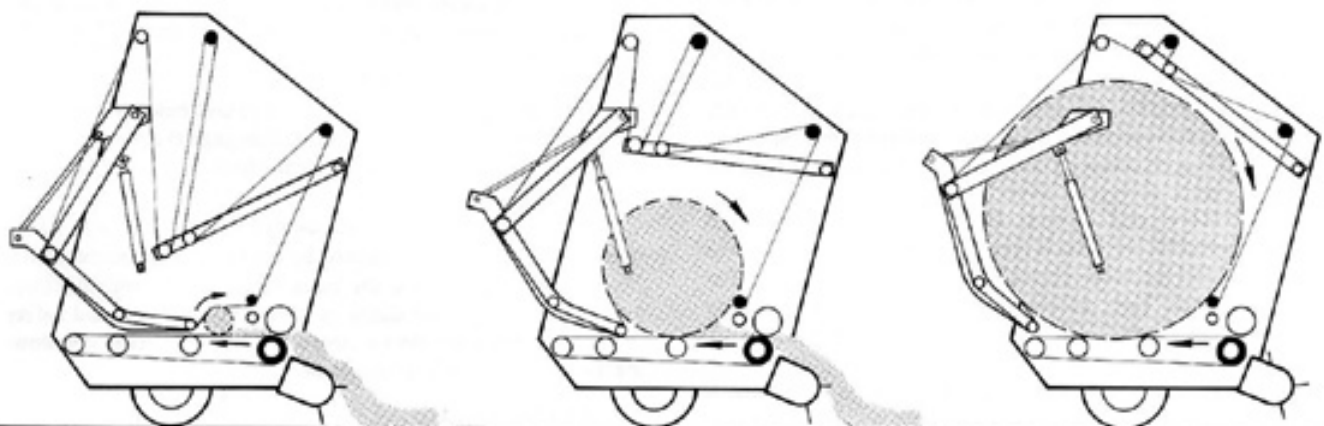

Figure 7. Stages of Bale Formation: (Left) Bale Core, (Centre) Half-Completed Bale, (Right) Completed Bale.

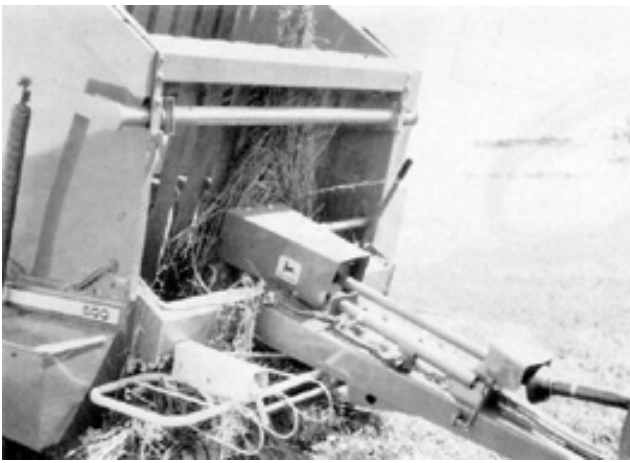

Figure 9. Plugging in Sweet Clover Before Compression Roll Modification.

ample hitch clearance for turning sharp corners. The baler could easily be towed behind a tractor or a suitably sized truck.

Hitching: The John Deere 500 could not be used on tractors with a drawbar height greater than 380 mm (15 in) as the pickup could not be lowered sufficiently for clean picking. Standard tractor drawbar heights vary from 330 to 432 mm (13 to 17 in). Since most tractors used in Western Canada are equipped with oversize tires, most have a drawbar height greater than 380 mm (15 in). Modifications to the baler to permit satisfactory pickup operation when used on tractors with drawbar heights greater than 380 mm (15 in) are recommended.

An "equal angle hitch" attachment (Figure 8) which extended the standard drawbar 205 mm (8 in) had to be used with the John Deere 500 baler. The standard horizontal distance between the end of the power take-off shaft and the drawpin hole is 355 mm (14 in) for a 540 rpm drive. On the John Deere 500, this distance to the hitch pivot is, in effect, extended to 560 mm (22 in) by the equal angle hitch. This design reduced driveline noise and allowed 90° turns but required bolting an extension to standard tractor drawbars.

It was difficult to keep the equal angle hitch attachment level and tightly fixed to the tractor drawbar, causing excessive impact loads on the tractor drawbar in rough fields. The equal angle hitch also increased the vertical load on the drawbar assembly due to the increased drawbar length. One tractor drawbar failure occurred during the test while baling on rough ground. A hitch design which eliminates the need for the equal angle hitch attachment is desirable.

Feeding: Feeding was positive and aggressive in nearly all crops with only infrequent plugging. One exception was in long, coarse-stemmed sweet clover. In sweet clover, the stalks often fed up the front of the forming belts (Figure 9) rather than through the compression rolls, causing plugging.

The manufacturer installed two modifications to improve feeding in sweet clover. The pickup compression bars were extended. This modification improved feeding slightly. Friction strips were then installed on the upper compression roller. The combined effect of these two modifications greatly reduced feeding problems in sweet clover.

Twine Threading: Twine threading was difficult. As recommended in the operator's manual, a length of stiff wire was needed to thread the twine through the twine tube. Although the operator's manual gave a clear description of twine threading procedures, most threading difficulties could be eliminated by repositioning the twine box.

The twine cutter performed well but periodic adjustments, as outlined in the operator's manual, were needed to ensure proper operation.

EASE OF ADJUSTMENT

Compression Rollers: The upper compression roller was held against the platform belt drive roller with adjustable springs. The operator's manual recommended that maximum contact pressure be maintained. All evaluation was conducted with maximum spring pressure; no adjustment was required during the test.

Forming Belts: Two adjustable springs maintain tension in the forming belts. No adjustment was required during the test once the springs had been set to the manufacturer's recommended length.

The forming belts were chain driven through the upper rollers. The drive chain needed frequent tightening. Unless it was tightened daily, the chain interfered with the chain shield during operation. A spring loaded chain tightener might eliminate this problem.

Platform Belt: Adjustable springs maintained platform belt tension. No spring adjustment was needed during the test, once the springs were set as recommended by the manufacturer.

Pickup: Pickup flotation was controlled by an adjustable spring while ground clearance was set with two adjustable stop screws. The pickup could not be lowered sufficiently for clean picking if the baler was hitched to a tractor with a drawbar height greater than 380 mm (15 in). The pickup drive belt had a spring-loaded tightener and did not need adjustment.

The pickup compression bars were not adjustable. The operator's manual recommended that the compression bars be installed only in light, short hay or in corn stalks. The compression bars were used throughout the test and performed well in all crops. Extending the compression bar fingers improved feeding in sweet clover.

The pickup tine pattern was circular and no adjustment of tine pattern was possible.

Servicing: The John Deere 500 had five chain drives, 28 grease fittings and one gear box. The operator's manual recommended chain oiling every 10 hours, lubrication of all grease fittings every 30 hours and checking gear box oil level and repacking the wheel bearings every season. About 20 minutes were needed to service the John Deere 500.

OPERATOR SAFETY

The John Deere 500 was safe to operate and service as long as common sense was used and the manufacturer's safety recommendations were followed. Rotating parts were well shielded.

On one occasion, a small stone wedged between the compression rolls. No damage resulted as the baler was stopped before the compression rolls became hot enough to cause a fire hazard. Other round balers have occasionally caught fire due to picking stones. A fire extinguisher should be mounted on the baler or tractor especially when baling in stony fields.

The John Deere 500 had a rear gate cylinder locks to permit safe servicing while the rear gate was open.

GENERAL SAFETY COMMENTS

The operator is cautioned that a round baler is potentially very dangerous. The operator *must* disengage the power take-off and stop the tractor engine to clear blockages or to make adjustments.

Many serious and fatal accidents have occurred with round balers. Most of these are caused by operators dismounting from the tractor while leaving the baler running. The manufacturer can only go to certain limits in providing shielding and safety devices and must rely on the operator's common sense in following established safety procedures.

OPERATOR'S MANUAL

The operator's manual was clear, well written and contain-

ed much useful information on operation, servicing, adjustments, and safety procedures. An instruction, warning the operator to carry a fire extinguisher while baling in stony fields should be included in the operator's manual.

Durability

Table 2 outlines the mechanical history of the John Deere 500 during 106 hours of field operation while baling about 375 ha (929 ac). The intent of the test was functional evaluation. The following failures represent only those which occurred during functional testing. An extended durability evaluation was not conducted.

Table 2. Mechanical History

<u>Item</u>	<u>Hours</u>
The power take-off input shaft retaining bolt was lost and replaced at	
The power take-off slip clutch casting broke and was replaced at	91

Discussion of Mechanical Problems

Retaining Bolt: The retaining bolt on the power take-off input shaft was lost during the first hour of use. The bolt was probably not properly tightened during assembly as no further problems occurred after replacement.

Slip Clutch Casting: The power take-off slip clutch casting broke after 91 hours. No cause was determined for the failure.

<i>Compression Rollers:</i>	
Number of rollers	2
Roller surface	Upper -- steel Lower -- rubber (platform belt drive roller)
Length	Upper -- 1536.7 mm (60.5 in) Lower -- 1524.0 mm (60.0 in)
Diameter	Upper -- 203 mm (8.0 in) Lower -- 213.2 mm (8.4 in)
<i>Pickup</i>	
Type	Floating cylindrical drum with spring teeth
Height adjustment	Adjustable stops
Width	1555 mm (61.2 in)
Number of tooth bars	4
Tooth spacing	65 mm (2.6 in)
Speed	105 rpm
Tooth pattern	Circular
<i>Twine System:</i>	
Capacity	2 balls
Recommended twine thickness	None
Twine feed and cutter	Hydraulic
<i>Safety Devices:</i>	
	Adjustable power take-off slip clutch, rear gate locks, totally enclosed power take-off
<i>Servicing:</i>	
Grease fittings	28, every 30 hours
Gear box	1, seasonal
Chains	5, every 10 hours
Wheel bearings	2, yearly
<i>Optional Equipment:</i>	
	Bale counter, power take-off shield adaptor kit

APPENDIX I

SPECIFICATIONS

<i>Make:</i>	John Deere Model 500 Round Baler
<i>Serial Number:</i>	317467E
<i>Overall Dimensions:</i>	
Ground clearance	260 mm (10.2 in)
Width	2430 mm (95.7 in)
Height	2840 mm (111.8 in)
Length	4100 mm (161.4 in)
<i>Tires:</i>	2, 11L x 14 SL, Farm Service
<i>Weight (with drawbar in field position and two balls of twine):</i>	
Left wheel	730 kg (1609.4 lb)
Right wheel	702 kg (1547.6 lb)
Hitchpoint	318 kg(1701.1 lb)
Total Weight	1750 kg (3 858.1 lb)
<i>Bale Chamber:</i>	
Width	1600 mm (63.0 in)
Maximum diameter	1880 mm (74.0 in)
Platform belt	
- number of belts	1
- belt width	1520 mm (59.8 in)
- thickness	5 mm (.20 in)
- belt speed	1.97 m/s (77.6 in/s)
Forming belts	
- number of belts	9
- belt width	101 mm (4.0 in)
- belt length	
- thickness	5 mm (0.20 in)
- spacing (centre to centre)	50 mm (2.0 in)
- belt speed	2.08 m/s (81.9 in/s)
Bale chamber tension method	Spring
Bale size indicator	Mechanical linkage

APPENDIX II

MACHINE RATINGS

The following rating scale is used in PAMI Evaluation Reports:

- | | |
|---------------|--------------------|
| (a) excellent | (d) fair |
| (b) very good | (e) poor |
| (c) good | (f) unsatisfactory |

APPENDIX III

METRIC UNITS

In keeping with the Canadian metric conversion program, this report has been prepared in SI units. For comparative purposes, the following conversion may be used:

1 hectare (ha)	= 2.47 acres (ac)
1 kilometre/hour (km/h)	= 0.62 miles/hour (mph)
1 tonne (t) = 2204.6 pounds (lb)	= 1.10 ton (ton)
1 tonne/hour (t/h)	= 1.10 ton/hour (ton/h)
1 tonne/hectare (t/ha)	= 0.45 ton/acre (ton/ac)
1000 millimetres(mm) = 1 metre (m)	= 39.37 inches (in)
1 kilowatt (kW)	= 1.34 horsepower (hp)
1 kilogram (kg)	= 2.20 pounds (lb)
1 tonne/kilowatt hour (t/kW.h)	= 0.82 tons/horsepower hour (ton/hp.h)



**ALBERTA
FARM
MACHINERY
RESEARCH
CENTRE**

3000 College Drive South
Lethbridge, Alberta, Canada T1K 1L6
Telephone: (403) 329-1212
FAX: (403) 329-5562
<http://www.agric.gov.ab.ca/navigation/engineering/afmrc/index.html>

Prairie Agricultural Machinery Institute

Head Office: P.O. Box 1900, Humboldt, Saskatchewan, Canada S0K 2A0
Telephone: (306) 682-2555

Test Stations:
P.O. Box 1060
Portage la Prairie, Manitoba, Canada R1N 3C5
Telephone: (204) 239-5445
Fax: (204) 239-7124

P.O. Box 1150
Humboldt, Saskatchewan, Canada S0K 2A0
Telephone: (306) 682-5033
Fax: (306) 682-5080