

Evaluation Report 99



Vermeer 605E Round Baler

A Co-operative Program Between



VERMEER 605E BALER

MANUFACTURER:

Vermeer Manufacturing Company
Pella, Iowa 50219
U.S.A.

DISTRIBUTOR:

Vermeer Manufacturing Co.
P.O. Box 1660
Kamsack, Saskatchewan
S0A 1S0

RETAIL PRICE:

\$6,497.00 (May, 1978, f.o.b. Humboldt).

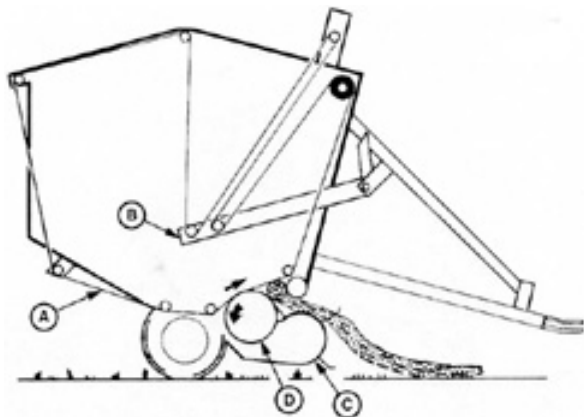

FIGURE 1. Vermeer 605E (A) Bale Forming Belts, (B) Tension Arm, (C) Pickup, (D) Platform Roller.

SUMMARY AND CONCLUSIONS

Overall functional performance of the Vermeer 605E round baler was *good*. Ease of operation and adjustment both were *good*, while operation of the twine wrapping mechanism was *fair*.

Average field speeds varied from 5 to 19 km/h (3.1 to 11.8 mph) while average throughputs varied from 1.7 to 7.5 t/h (1.9 to 8.3 ton/h). Maximum instantaneous feedrates of up to 14 t/h (15.4 ton/h) were measured in heavy, uniform alfalfa windrows. Ground speed was usually limited by pickup loss and not by baler capacity. Feeding was aggressive in all crops, but was reduced somewhat in long, coarse-stemmed material due to pickup plugging.

Bales were well formed and neat in appearance. The Vermeer 605E produced bales with an average length of 1.6 m (63 in) and an average diameter of 1.7 m (67 in). Hay bales weighed from 400 to 680 kg (880 to 1500 lb) with an average density of 151 kg/m³ (9.4 lb/ft³).

Resistance of hay bales to moisture penetration was *good*.

Peak power take-off requirements were about 17 kW (23 hp) in hay and straw on flat firm fields. More power was required in hills or on soft ground.

Leaf loss was comparable to that of other large round balers. In heavy crops, at near optimum moisture content, bale chamber loss was 1% and pickup loss was 8%. In light dry alfalfa, average bale chamber loss was 8% and pickup loss was 12%. Heavy windrows, proper conditioning and baling at the maximum permissible moisture content, all were important in reducing bale chamber loss.

The Vermeer 605E was safe to operate if the manufacturer's safety recommendations were closely followed.

RECOMMENDATIONS

It is recommended that the manufacturer consider:

1. Installation of pickup side shields as standard equipment.
2. Modifications to eliminate gate lock malfunction due to hay buildup.
3. Modifying the tying mechanism to reduce latching problems associated with hay buildup on the twine tube lock.
4. Modifying shielding to improve ease of servicing.
5. Installation of mechanical gate cylinder locks to improve operator safety while servicing the baler with the gate in raised position.
6. Modifications to eliminate interference between the bale starter roller and the pickup teeth when the pickup is in transport position.

Chief Engineer -- E. O. Nyborg

Senior Engineer -- L. G. Smith

Project Technologist -- D. H. Kelly

THE MANUFACTURER STATES THAT

With regard to recommendation number:

1. Pickup side shields are standard equipment on the 605F series.
2. On the "F" series, a double lock is used and is located on the outside of the machine where hay buildup cannot occur.
3. The twine cutter has been redesigned and is installed on the twine tube on the "F" series.
4. All shields have been hinged for easy access on the "F" series.
5. We have never had a gate close accidentally. The "F" series has a hydraulic lock which prevents gate closing even if a hose breaks.
6. Instruction manual for the "F" series cautions the operator to rotate the power take-off until the teeth are not pointing at the starter roller.

MANUFACTURER'S ADDITIONAL COMMENTS

All the above suggestions for improvements have been incorporated into the new "F" series. In addition, we have included hydraulic tensioning on the belt tightener assembly to give higher bale density. Density is now variable from 128 kg/m³ (8.0 lb/ft³) to 232 kg/m³ (14.5 lb/ft³).

GENERAL DESCRIPTION

The Vermeer 605E is a pull-type, power take-off driven baler with a cylindrical baling chamber and a floating drum pickup. The twine wrapping mechanism is manually actuated.

Hay is fed directly into the baling chamber by the pickup. The baling chamber consists of a full width platform roller on the bottom and a set of two 255 mm (10 in) wide belts and five 103 mm (4 in) wide belts on the top. The platform roller rotates in a fixed location while the spring loaded forming belts position themselves around the bale during formation.

Detailed specifications are given in APPENDIX I.

SCOPE OF TEST

The Vermeer 605E was operated in a variety of Saskatchewan crops (TABLES 1 and 2) for 96 hours while producing 518 bales. It was evaluated for rate of work, quality of work, power consumption, ease of operation, ease of adjustment, operator safety and suitability of the operator's manual.

TABLE 1. Operating Conditions.

| CROP | HOURS | NUMBER OF BALES | FIELD AREA | |
|---|-----------|-----------------|------------|--------------|
| | | | ha | (ac) |
| Alfalfa | 20 | 89 | 38 | (94) |
| Alfalfa, Bromegrass & Crested Wheatgrass | 33 | 151 | 50 | (123) |
| Alfalfa & Spring Rye Mixture | 26 | 103 | 48 | (119) |
| Green Feed | 1 | 5 | 1 | (2.5) |
| Slough Hay | 1 | 8 | 1 | (2.5) |
| Wheat Straw | 10 | 30 | 33 | (82) |
| Oat Straw | 2 | 38 | 10 | (25) |
| Barley Straw | 1 | 13 | 2 | (5) |
| Oat & Wheat Straw | 2 | 18 | 3 | (7) |
| TOTAL | 96 | 518 | 186 | (460) |

TABLE 2. Operation in Stony Fields.

| FIELD CONDITION | HOURS | FIELD AREA | |
|-------------------|-----------|------------|--------------|
| | | ha | (ac) |
| Stone free | 73 | 115 | (284) |
| Occasional stones | 11 | 34 | (84) |
| Moderately stony | 11 | 35 | (87) |
| Very stony | 1 | 2 | (5) |
| TOTAL | 96 | 186 | (460) |

RESULTS AND DISCUSSION

RATE OF WORK

Average throughputs for the Vermeer 605E (TABLE 3) varied from 1.7 t/h (1.9 ton/h) in alfalfa and spring rye mixture to 7.5 t/h (8.3 ton/h) in oat straw. The average throughputs reported in TABLE 3 are average workrates for daily field operation. They are representative of the actual workrates that may be expected in typical field operation. These values are based on the total operating time and the total baler throughput for each day of baling.

In heavy, uniform alfalfa windrows, instantaneous feedrates up to 14 t/h (15.4 ton/h) were measured. These were peak values, representing maximum baler capacity, which cannot be achieved continuously.

In most crops, the feedrate was limited by pickup performance and not by bale chamber capacity. Pickup loss usually limited ground speed from 5 to 19 km/h (3.1 to 11.8 mph). Heavy windrows were desirable to fully utilize baler capacity.

Feeding was aggressive in all crops except in long coarse hay where capacity was reduced by occasional plugging at the pickup.

TABLE 3. Average Throughputs.

| CROP | YIELD | | AVERAGE SPEED | AVERAGE THROUGHPUT |
|--|-------------|--------------|---------------|--------------------|
| | t/ha | (ton/ac) | | |
| Alfalfa | 1.0 to 3.5 | (0.4 to 1.6) | 6.8 (4.2) | 4.3 (4.7) |
| Alfalfa, Bromegrass & Crested Wheatgrass | 1.0 to 4.7 | (0.4 to 2.1) | 8.4 (5.2) | 4.4 (4.9) |
| Alfalfa & Spring Rye Mixture | 0.75 to 1.0 | (0.3 to 0.4) | 9.7 (6.0) | 1.7 (1.9) |
| Green Feed | 3.0 | (1.3) | 5.0 (3.1) | 3.0 (3.3) |
| Slough Hay | 3.0 | (1.3) | 6.5 (4.0) | 3.0 (3.3) |
| Wheat Straw | 1.0 to 2.0 | (0.4 to 0.8) | 12.7 (7.9) | 5.0 (5.3) |
| Oat Straw | 1.0 to 2.0 | (0.4 to 0.8) | 19.0 (11.8) | 7.5 (8.3) |
| Barley Straw | 1.5 to 2.0 | (0.6 to 0.8) | 12.0 (7.5) | 3.5 (3.9) |
| Oat & Wheat Straw | 1.5 to 2.0 | (0.6 to 0.8) | 9.0 (5.6) | 2.6 (2.9) |

QUALITY OF WORK

Bale Quality: The Vermeer 605E produced firm, durable bales (FIGURE 2) with flat ends, uniform density and uniform diameter. Bales averaged 1.6 m (63 in) in length and 1.7 m (67 in) in diameter. Average hay bales weighed from 400 to 680 kg (880 to 1500 lb) with an average density of 151 kg/m³ (9.4 lb/ft³).



FIGURE 2. Typical Hay or Straw Bale.

Bale Weathering: A common practice in the prairie provinces is to store round bales outside. FIGURE 3 shows the effect of weathering on a typical Vermeer 605E hay bale (bromegrass and alfalfa mixture) after 100 days of weathering. The weathering period was the time between baling and freeze-up. Bales were situated in a well-drained area with prevailing winds striking one side of the bales. During weathering, bales were exposed to about 75 mm (3 in) of rain and average prairie wind conditions.

The condition of weathered bales was good. The relatively high bale density and the well formed surface had kept moisture penetration to a maximum of 90 mm (3.5 in) on the windward bale side. Bales had retained 91% of their original height. As a result, bales were easy to pick with round bale handlers.

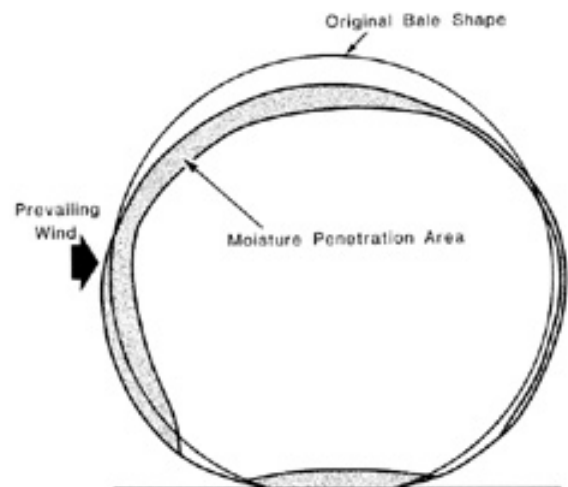

FIGURE 3. A Typical Hay Bale after 100 Days of Weathering.

Pickup and Bale Chamber Loss: Measured hay loss from the Vermeer 605E (TABLE 4) varied from 9% in heavy windrows to

20% in light dry windrows. Bale chamber loss was usually somewhat lower than for other round balers. A large portion of the pickup loss was due to hay falling off the pickup sides when filling the bale ends. The optional pickup side shields should reduce pickup loss in some crops.

Lowest losses occurred in windrows which were heavy enough to fully utilize baler capacity and which were baled at high moisture contents. Proper conditioning of hay was important, especially in alfalfa, to reduce the moisture content of the stems and to permit baling with a fairly high leaf moisture content. While the moisture content of an unconditioned alfalfa windrow may be at a level to just permit safe storage, the leaves may be quite dry and brittle and susceptible to shattering.

To minimize bale chamber losses with a round baler, the feed-rate should be as high as possible to minimize time in the baling chamber. This is illustrated by the third and fourth crops reported in TABLE 4. In the third crop it took only two minutes to form a bale and bale chamber losses were only 1%. In the fourth crop, it took nine minutes to form a bale and bale chamber losses were 10%. Pickup losses were similar in both crops. It is often more economical to allow some pickup loss, by driving too fast, as the total loss level will be reduced due to a decreased bale chamber loss. Bale chamber losses in light crops can also be reduced by running the tractor at a lower power take-off speed. This results in fewer turns to form a bale. Power take-off speed must, however, be fast enough for satisfactory pickup performance.

TABLE 4. Pickup and Bale Chamber Losses

| CROP | YIELD (t/ha, cwt/acre) | SWATH WIDTH m (ft) | MOISTURE CONTENT (% dry basis) | LOSS (% OF YIELD) | | |
|-------------------------|---------------------------|--------------------------|--------------------------------------|-------------------|--------|-------|
| | | | | Bale Chamber | Pickup | Total |
| Alfalfa | 2.7 (1.2) | 2.7 (12) | 18.1 | 8 | 12.0 | 20 |
| Alfalfa & Bromegrass | 2.5 (1.1) | 3.7 (12) | 22.2 | 10 | 5 | 15 |
| Alfalfa & Bromegrass | 4.0 (1.8) | 4.6 (15) | 10.0 | 1 | 9 | 9 |
| Alfalfa & Bromegrass | 1.4 (0.6) | 4.6 (15) | 16.7 | 10 | 9 | 19 |

POWER CONSUMPTION

Power Requirements: FIGURE 4 shows the power take-off and drawbar input for the Vermeer 605E in alfalfa. The power input is plotted against bale weight to show the power requirements as a bale is being formed. Power take-off input varied from 5 kW (6 hp) at no load to a maximum of 17 kW (23 hp) in alfalfa and barley straw. Drawbar power requirements at 7 km/h (4.4 mph) were 3 kW (4 hp).

Although maximum power requirements did not exceed 20 kW (27 hp), additional power was needed to suit field conditions. In soft, hilly fields, a 75 kW (100 hp) tractor was needed to fully utilize baler capacity.

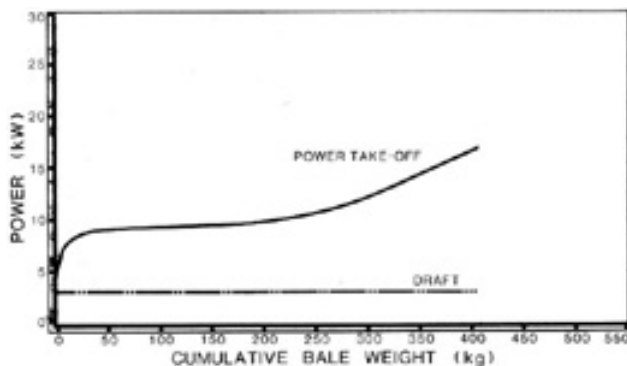

FIGURE 4. Power Consumption During Bale Formation in Alfalfa.

Specific Capacity: Specific capacity is a measure of how efficiently a machine performs a task. A high specific capacity indicates efficient energy use while low specific capacity indicates inefficient operation. The specific capacity of the Vermeer 605E was about 0.41 t/kW.h (0.34 ton/hp.h) in alfalfa and 0.31 t/kW.h (0.25 ton/hp.h) in wheat straw. This compares to an average specific capacity of 0.98 to 1.45 t/kW.h (0.8 to 1.2 ton/hp.h) for small square balers in alfalfa. These values represent average operating speeds in average field conditions and not peak outputs.

EASE OF OPERATION

Forming a Bale: An inexperienced operator had some difficulty starting a bale with the Vermeer 605E, but once experience was gained, it was relatively easy to form a neat, durable bale. When starting a bale, it was important to weave the baler back and forth across the windrow, to feed hay evenly across the width of the baling chamber. If the baler was fed on one side during core formation, forming a core of varying diameter, the bale forming belts slipped past the smaller core end preventing proper bale formation. If this happened, the baler had to be stopped, the bale core ejected and the belts repositioned manually. Once the bale core was properly formed, slight weaving was needed during bale formation to maintain a uniform bale diameter.

FIGURE 5 shows the position of the forming belts during bale formation.

Wrapping the Twine: A mechanical indicator at the front of the baler indicates when a bale is full size and ready for twine wrapping. As a safety device, an adjustable pickup release disengages the pickup drive to prevent overfilling.

To start wrapping, the twine tube lock is released with a rope, causing a spring to pull the twine tube to the left of the bale chamber. Once the twine has been caught by the hay entering

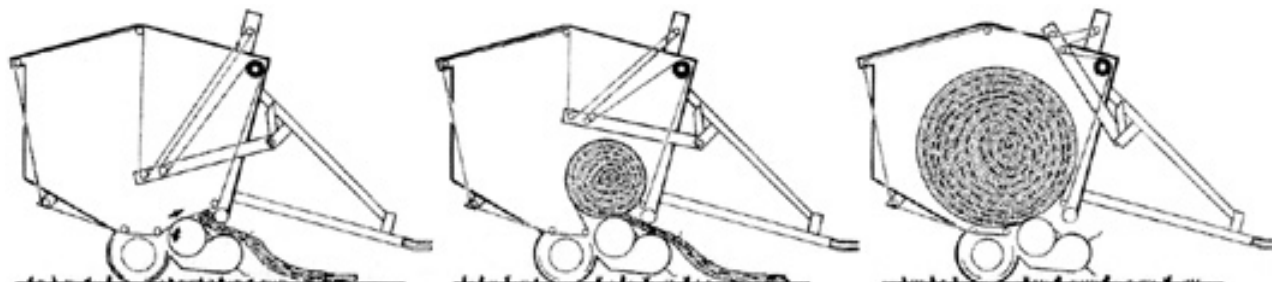

FIGURE 5. Stages of Bale Formation: (Left) Bale Core, (Centre) Half-Completed Bale, (Right) Completed Bale.

the bale chamber, the operator stops, tractor forward travel, but allows the power take-off to run. When the twine has made at least a full wrap around the left end of the bale, the operator slowly pulls the rope moving the twine tube across the front of the bale. The rate at which the rope is pulled determines the number of wraps around the bale. When the twine tube reaches the right side of the bale, the operator momentarily holds the rope so there is at least one complete wrap around the right bale end. The operator then slowly pulls the rope, returning the twine tube to the latch position, where the twine is automatically cut.

The twine tube mechanism (FIGURE 6) has a steel twine tube lock positioned so that its weight holds the twine tube in the latched position. To release the lock, the operator pulls sharply on the twine rope, causing the tube to move upward, striking the tube lock and forcing it to swing out of the latched position. The twine tube then has to be lowered before the lock plate swings back into its normal position. To relatch, the twine tube is slowly moved upwards until the tube lock latches on the end of the tube.

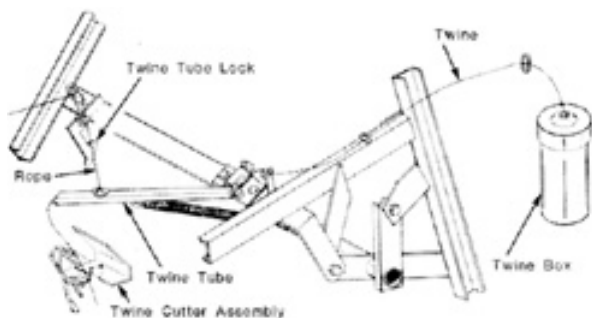

FIGURE 6. Twine Wrapping Mechanism.

On several occasions, hay buildup on the tube lock (FIGURE 7) prevented proper latching. Hay restricted free movement of the tube lock and would not allow the twine tube to be lowered for bale wrapping. Hay buildup also interfered with the tube lock when returning the twine tube to the latched position. Modifications to the twine wrapping mechanism to reduce problems associated with hay buildup are recommended.



FIGURE 7. Hay Buildup on Twine Wrapping Mechanism.

Twine consumption for the Vermeer 605E was about 98 m/t (291 ft/ton). This compares to a twine consumption of about 225 m/t (670 ft/ton) for small square balers.

Discharging a Bale: Once the twine is cut, the power takeoff is shut off and the tractor and baler are backed up about 6 m (20 ft).

The gate is hydraulically opened, and the bale falls out of the bale chamber. The tractor and baler are then moved ahead about 4.5 m (15 ft) and the gate closed. A slight pressure is required on the gate hydraulic cylinders to ensure that the gate lock is activated. About one minute was needed to wrap and discharge a bale.

During baling, fine hay accumulated between the bale forming belts (FIGURE 8). When discharging a bale, this hay usually fell on the gate lock mechanism sometimes preventing proper locking. If baling was resumed with the gate unlocked, it opened during baling preventing proper bale formation. Modifications to the rear gate lock mechanism, to eliminate lock malfunction due to hay buildup, are recommended.

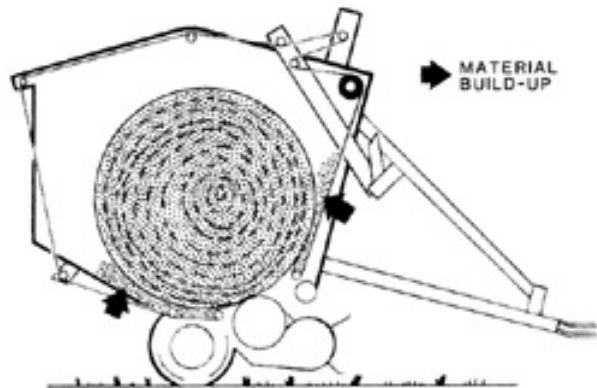

FIGURE 8. Hay Buildup Between Belts.

Transporting: The Vermeer 605E was easy to maneuver and transport. Ground clearance was adequate and there was ample hitch clearance for turning sharp corners. The baler could easily be towed behind a tractor or a small truck.

Interference occurred between the pickup teeth and the bale starter roller when placing the pickup in the transport position. Occasionally, this interference damaged the pickup teeth. Modifications to eliminate interference between the bale starter roller and the pickup teeth are recommended.

The Vermeer 605E was easy to hitch to a tractor. If the tractor was equipped with a cab, it was sometimes difficult to find a suitable place for the twine rope to enter the cab and have the rope completely operative. The Vermeer 605E required a tractor with single hydraulics.

Feeding: Feeding was positive and aggressive in nearly all crops with only infrequent plugging. One exception was in long coarse-stemmed hay, such as sweet clover. In such hay, stalks occasionally fed between the bale forming belts rather than rolling into a bale core. This problem occurred only while starting the bale core and once the bale was about 0.3 m (1 ft) in size, feeding was positive.

The long coarse-stemmed hay also sometimes caused pickup plugging (FIGURE 9). While filling the bale ends by feeding the windrow at the extreme edges of the pickup, the long hay hair-pinned on the baler side members causing the pickup drive belt to slip. Use of the optional pickup side shields should reduce this problem.

Twine Threading: Twine threading was quite easy, however, a stiff piece of wire was needed to thread the twine through the twine tube.

The twine cutter performed well and no adjustments were needed during the test.



FIGURE 9. Hair-pinning of Long Hay on Baler Side Members.

EASE OF ADJUSTMENT

Forming Belts: Two sets of adjustable springs maintain tension in the forming belts. No adjustment was required during the test once the springs had been set to the manufacturer's recommended length.

The forming belts and the bale starter roller were chain driven. The drive chain was spring tensioned needing only infrequent adjustment.

Platform Roller: The platform roller was chain driven from the bale starter roller. The drive chain was spring tensioned and needed no adjustment during the test.

Pickup: Pickup flotation was controlled by a set of adjustable springs which also were used to set pickup ground clearance. The pickup was set at the recommended 75 mm (3 in) clearance between the pickup teeth and the ground and did not need adjustment during the test. The pickup drive belt had a spring loaded tightener and needed no adjustment.

Pickup tooth pattern was cam controlled and was not adjustable.

Both the height and maximum flotation limit of the pickup compression bars were adjustable. Once proper settings were determined, no adjustments were needed.

Servicing: The Vermeer had two chains, 26 grease fittings and one gearbox. The operator's manual recommended checking the chains every two to four hours and using a spray lubricant when needed. The operator's manual also recommended daily lubrication of all grease fittings and checking gearbox level and repacking wheel bearings every season.

About 30 minutes were needed to service the Vermeer 605E. All chains and most grease fittings were located behind shields which had to be removed for servicing. Modifications to the shielding to improve ease of servicing is recommended.

OPERATOR SAFETY

The Vermeer 605E was safe to operate and service, as long as common sense was used and the manufacturer's safety recommendations were followed. Rotating parts were very well shielded.

The Vermeer 605E did not have mechanical gate cylinder locks to fix the gate in raised position for servicing. A hydraulic safety valve is supplied to prevent accidental opening or closing of the rear gate while working around the baler, however, installation of mechanical cylinder stops is recommended.

The Vermeer 605E was equipped with an automatic pickup release that disengaged the pickup drive when the bale chamber was full. This acted as a safety device to protect the baler from damage due to overfilling the bale chamber. The Vermeer was also equipped with an adjustable slip clutch on the main power take-off drive.

GENERAL SAFETY COMMENTS

The operator is cautioned that a round baler is potentially very dangerous. The operator must disengage the power take-off and stop the tractor engine to clear blockages or to make adjustments.

Many serious and fatal accidents have occurred with round balers. Most of these are caused by operators dismounting from the tractor while leaving the baler running. The manufacturer can only go to certain limits in providing shielding and safety devices and must rely on the operator's common sense in following established safety procedures.

OPERATOR'S MANUAL

The operator's manual was clear and well written, containing much useful information on operation, servicing, adjustment, and safety procedures.

DURABILITY RESULTS

TABLE 5 outlines the mechanical history of the Vermeer 605E during 96 hours of field operation while baling about 186 ha (460 ac). The intent of the test was functional evaluation. The following failures represent only those which occurred during functional testing. An extended durability evaluation was not conducted.

TABLE 5. Mechanical History

| ITEM | OPERATING HOURS | EQUIVALENT NUMBER OF BALES |
|--|-----------------|----------------------------|
| <i>Pickup Teeth</i> | | |
| --Six pickup teeth became damaged and were replaced at | 78 | 420 |
| <i>Bale Forming Belts</i> | | |
| --Fraying of bale forming belt edges was observed at | 71 | 383 |

DISCUSSION OF MECHANICAL PROBLEMS

Pickup Teeth: Six pickup teeth bent due to interference between pickup teeth and bale starter roller when raising the pickup into transport position. Pickup teeth were easily replaced by removal of adjacent pickup guards.

Bale Forming Belts: The edges of all the bale forming belts began to fray due to rubbing on the belt guides. Belt lacings also began to separate. By the end of test, the belt guides were deeply notched from belt wear.

APPENDIX I

SPECIFICATIONS

MAKE: Vermeer Round Baler
 MODEL: 605E
 SERIAL NUMBER: 1000
 MANUFACTURER: Vermeer Manufacturing Company
 Pella, Iowa 50219
 U.S.A.

OVERALL DIMENSIONS:

-- width 2430 mm (96 in)
 -- height 2655 mm (105 in)
 -- length 4200 mm (165 in)

TIRES:

-- size 2, 11 x 15 Lt, 6 ply

WEIGHT:

(With drawbar in field position and two balls of twine)

-- left wheel 798 kg (1760 lb)
 -- right wheel 730 kg (1609 lb)
 -- hitch point 304 kg (670 lb)

Total Weight 1832 kg (4039 lb)

BALE CHAMBER:

-- width 1553 mm (61 in)
 -- maximum diameter 1790 mm (70 in)
 -- tension method spring

PLATFORM ROLLER:

-- length 1535 mm (60 in)
 -- diameter 420 mm (16.5 in)
 --- roller speed (at 540 rpm) 130 rpm

FORMING BELTS:

-- number of belts 7
 -- belt width 2 - 255 mm (10 in)
 5 - 103 mm (4 in)
 -- belt length 11.3 m (445 in)
 -- thickness 5 mm (0.2 in)
 -- spacing (centre to centre) 127 mm (5 in)
 -- belt speed (at 540 rpm) 2.8 m/s (108.6 in/s)

BALE SIZE INDICATOR:

Mechanical linkage

PICKUP:

-- type floating cylindrical drum with spring teeth
 -- height adjustment adjustable spring
 -- width 1500 mm (59 in)
 -- diameter 540 mm (21 in)
 -- number of tooth bars 6
 -- tooth spacing 75 mm (3 in)
 -- speed (@ 540 rpm) 97 rpm

TWINE SYSTEM:

-- capacity 2 balls
 -- recommended twine size none
 -- twine feed manual
 -- twine cutter manual

SAFETY DEVICES:

adjustable power take-off
 slip clutch, automatic pickup
 release when bale full, rear
 gate hydraulic safety valve.

SERVICING:

-- grease fittings 26, daily
 -- chains 2, daily
 -- wheel bearings 2, yearly
 -- gearbox 1, yearly

APPENDIX II

MACHINE RATINGS

The following rating scale is used in PAMI Evaluation Reports:

| | |
|---------------|--------------------|
| (a) excellent | (d) fair |
| (b) very good | (e) poor |
| (c) good | (f) unsatisfactory |

APPENDIX III

METRIC UNITS

In keeping with the Canadian metric conversion program this report has been prepared in SI Units. For comparative purposes, the following conversions may be used.

| | |
|--------------------------------|--|
| 1 hectare (ha) | = 2.47 acres (ac) |
| 1 kilometre/hour (km/h) | = 0.62 miles/hour (mph) |
| 1 tonne (t) | = 2204.6 pounds (lb) |
| 1 tonne/hour (t/h) | = 1.10 ton/hour (ton/h) |
| 1 tonne/hectare (t/ha) | = 0.45 ton/acre (ton/ac) |
| 1000 millimetres (mm) | = 1 metre (m) |
| 1 kilowatt (kW) | = 1.34 horsepower (hp) |
| 1 kilogram (kg) | = 2.20 pounds (lb) |
| 1 tonne/kilowatt hour (t/kW.h) | = 0.82 tons/horsepower hour (ton/hp.h) |



**ALBERTA
FARM
MACHINERY
RESEARCH
CENTRE**

3000 College Drive South
Lethbridge, Alberta, Canada T1K 1L6
Telephone: (403) 329-1212
FAX: (403) 329-5562
<http://www.agric.gov.ab.ca/navigation/engineering/afmrc/index.html>

Prairie Agricultural Machinery Institute

Head Office: P.O. Box 1900, Humboldt, Saskatchewan, Canada S0K 2A0
Telephone: (306) 682-2555

Test Stations:
P.O. Box 1060
Portage la Prairie, Manitoba, Canada R1N 3C5
Telephone: (204) 239-5445
Fax: (204) 239-7124

P.O. Box 1150
Humboldt, Saskatchewan, Canada S0K 2A0
Telephone: (306) 682-5033
Fax: (306) 682-5080