

# Evaluation Report 588

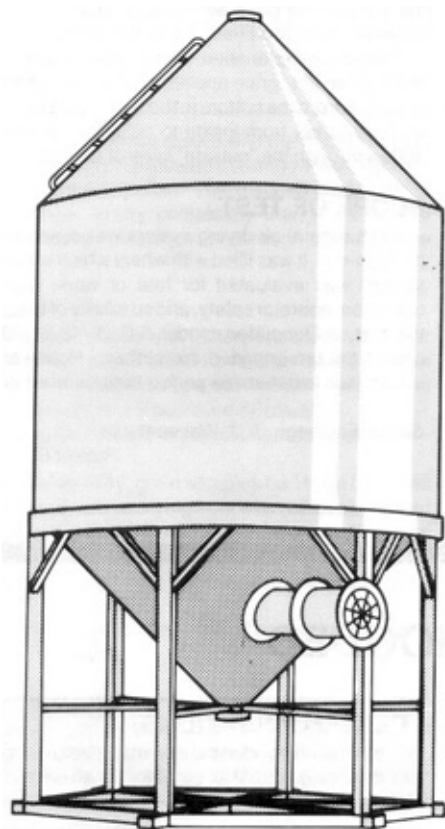

**Bader Hooded  
Grehi  
Harvest Hopper  
Trail Rite V Aeration  
Univision In-Line  
Univision Ultra-Dry  
Westeel Boot**

## Hopper Bin Natural Air Drying Systems

A Co-operative Program Between



# HOPPER BIN NATURAL AIR DRYING SYSTEMS

## TERMINOLOGY

### DRYING TIME

Natural air drying time is dependent on many factors, including grain moisture content, airflow rate, drying uniformity, weather and the air distribution system shape and location. Because so many factors affect the drying time, it is unrealistic to directly compare the actual drying times of different systems tested at different times. For this reason, PAMI uses a reference bin to compare drying times. The reference bin is a flat bottom bin with a fully perforated drying floor and holding capacity equivalent to the test bins. The reference bin is operated along with each test bin under the same test conditions. Each test bin drying time can then be directly compared to the reference bin and a relative drying time can be obtained. This relative drying time can be used to compare drying times for different bins tested at different times.

Both average and through-drying times are stated in this report. Average-drying refers to drying until the average of all the grain is dry (14.5% moisture content for wheat). Some grain will still be wet while some will be overdried. However, if all the grain is unloaded and mixed, the overall average moisture content will be dry. Through-drying refers to drying until all of the grain in the bin is dry. Normally, some of the grain is overdried with this practice.

Two main factors of the natural air drying system that contribute to drying time are the airflow rate permitted by the system and the drying uniformity. These are each discussed in the following sections.

### AIRFLOW

The airflow rate in a natural air drying system is a measure of how much air is moving through each unit of grain [(cfm/bu (L/s•m<sup>3</sup>)). The airflow rate is dependent on the air distribution system design, the power and efficiency of the fan being used, and other factors. For comparison purposes, the airflow rates in this report are based on "typical" fans, and not the fans used in the tests. The fan data is an average of the performance of all centrifugal and in-line centrifugal fans currently available in the particular power group. Actual system performance may vary, depending on the fan and on the grain being dried in a particular installation.

### DRYING UNIFORMITY

Drying uniformity in a natural air drying system depends on the uniformity of the airflow through the bin. Ideally, the natural air drying system should provide uniform airflow through all parts of the bin. If the airflow is uniform throughout the bin, the top layer of grain through which the air passes will dry all at the same time. If the airflow is not uniform, parts of this top layer of grain will take longer to dry than other parts. While the last part is being dried, the air passing through already dried parts of the top layer is being wasted.

Drying uniformity, is important when through-drying but less important if the operator is average-drying the grain. When average-drying the grain, if the top layer is mixed before it starts to dry, none of the air passing through the grain is wasted.

PAMI measures the drying uniformity of natural air drying systems by comparing them to an ideal system. The time required for all the top layer of grain to dry for the system is compared to the time required for the top layer to dry if airflow was ideal. The smaller the difference between these two times, the better rating.

The above explanation, which rates the uniformity of airflow through the "top" layer of grain applies to bins in which the primary air direction is vertical from the bottom to the top. Some bins are designed to move air horizontally from inside to outside. On these bins, uniformity of airflow through the "outside" layer of grain is measured.

### SCOPE OF TEST

Each natural air drying system was operated in a hopper bin until through-dry. It was filled with wheat which was peaked at the top. The system was evaluated for rate of work, quality of work, ease of operation, operator safety, and suitability of the operator's manual. For the test, a Denouden model ILC 21/18-312 3 hp (2.2 kW) in-line centrifugal fan provided the airflow. However, the report provides information to determine performance with other fans installed.

Senior Engineer: J. D. Wassermann

Project Engineer: D. E. Lischynski

Project Technologist: W. F. Stock

## BADER HOODED

### MANUFACTURER AND DISTRIBUTOR:

Gus Bader & Son Agri Products Inc.  
1150 High St. W.  
P.O. Box 1330  
Moose Jaw, Saskatchewan  
S6H 4R3  
(306) 693-7555

### RETAIL PRICE:

\$875.00, (October 1988, f.o.b. Humboldt, Saskatchewan )

### RECOMMENDATIONS

It is recommended that the manufacturer consider:  
1. Providing natural air guidelines with each system.

### THE MANUFACTURER STATES THAT

With regard to recommendation number:  
1. Fan installation instructions are included with each system. Operating procedures on natural air drying can be determined from pamphlets available from the Departments of Agriculture in both Saskatchewan and Manitoba.

### SUMMARY AND CONCLUSIONS

Average-drying time was 0.70 times the reference bin. Through-drying time was 1.20 times the reference bin.

Airflow rate was 1.15 cfm/bu (15.0 L/s•m<sup>3</sup>) with a typical 3 hp (2.2 kW) fan. Drying uniformity results indicated that parts of the top layer of grain took 32% longer to dry than if airflow uniformity was ideal.

The natural air drying system could be field installed in Bader bins. Ease of installing the fan was fair. Ease of cleaning was very good.

No operator's manual was provided and no mechanical problems were encountered. The system could be epoxy coated for storing fertilizer.

### GENERAL DESCRIPTION

The Bader Hooded hopper bin natural air drying system consists of several ducts located on the bottom of the hopper with open ends. Air from the fan enters a plenum which is a triangular double wall support that circles the top of the hopper. Twenty round holes in the hopper allow air to enter the ducts. The ducts are tapered lengthwise and several are fitted inside of each other extending down the hopper, with openings at the end of each to permit air entry to the grain. The configuration is shown in FIGURE 1

## RESULTS AND DISCUSSION

### RATE OF WORK

**Drying Time:** The time for the Bader Hooded hopper bin natural air drying system to average-dry a 16 ft (4.9 m) diameter bin with 1940 bu (70.6 m<sup>3</sup>) of wheat was 0.70 times the reference bin. In drying conditions that would take the reference bin 14 days to reach average-dry, the Bader would take 10 days.

The time for the Bader Hooded hopper bin natural air drying system to through-dry a bin of wheat was 1.20 times the reference bin. In drying conditions that would take the reference bin 21 days to reach through-dry, the Bader would take 25 days.

### QUALITY OF WORK

**Airflow:** Expected airflow rates with three different typical fan sizes are given in TABLE 1. For example, a typical 3 hp (2.2 kW) fan would achieve an airflow rate of 1.15 cfm/bu (15.0 L/s•m<sup>3</sup>). Note that these values will vary if the grain has a different airflow resistance.

TABLE 1. Bader Hooded Airflow Rates in Wheat.

TYPICAL FAN SIZE hp (kW)	1 to 2 (0.75 to 1.5)	3 (2.2)	5 (3.7)
EXPECTED AIRFLOW RATE cfm/bu (L/s•m <sup>3</sup> )	0.80 (10.4)	1.15 (15.0)	1.45 (18.9)

**Drying Uniformity:** Drying uniformity results with the Bader Hooded hopper bin natural air drying system indicated that airflow was higher at the bin edges than in the centre of the bin. This resulted in parts of the top layer taking 32% longer to dry completely than if the airflow uniformity was ideal. The last grain to dry when through-dry was at the top centre of the bin.

### EASE OF OPERATION

**Installation:** The Bader Hooded was factory installed in a Bader Model B1609040E bin. The system could be field installed in Bader bins. Ease of installing the in-line centrifugal fan was fair. The fan had to be lifted above shoulder height and positioned vertically.

**Monitoring:** Monitoring for average dry was fair and for the through-dry was good.

To determine when average-dry, grain samples had to be collected from many locations in the bin as the drying front was not level. Instead it was lower at the centre of the bin. This was inconvenient, but is typical of many natural air drying systems. To determine through-dry, a grain sample could be collected through the grain filler hole, as the last grain to dry was at the top centre of the bin.

**Cleaning:** Ease of cleaning was very good. The natural air drying system did not affect bin unloading.

### FAN REQUIREMENTS

Fan requirements in wheat for various airflow rates are given in TABLE 2. For example, to obtain an airflow rate of 1 cfm/bu (13 L/s•m<sup>3</sup>), the fan must be able to deliver an airflow of 1940 cfm (910 L/s) at a static pressure of 3.7 in•wg (930 Pa). Note that these values will vary if the grain has a different airflow resistance.

TABLE 2. Bader Hooded Fan Requirements in Wheat.

DESIRED AIRFLOW RATE cfm/bu (L/s•m <sup>3</sup> )		0.5 (6.5)	0.75 (9.8)	1.0 (13)	1.25 (16.3)	1.5 (19.5)
MINIMUM FAN PERFORMANCE	STATIC PRESSURE in•wg (Pa)	1.4 (350)	2.5 (630)	3.7 (930)	8.1 (1280)	6.5 (1630)
	AIRFLOW cfm (L/s)	970 (460)	1480 (680)	1940 (910)	2420 (1140)	2900 (1360)

### OPERATOR SAFETY

No safety hazards were apparent when normal precautions were observed.

### OPERATOR'S MANUAL

No operator's manual was provided. It is recommended that the manufacturer provide natural air drying guidelines with each system.

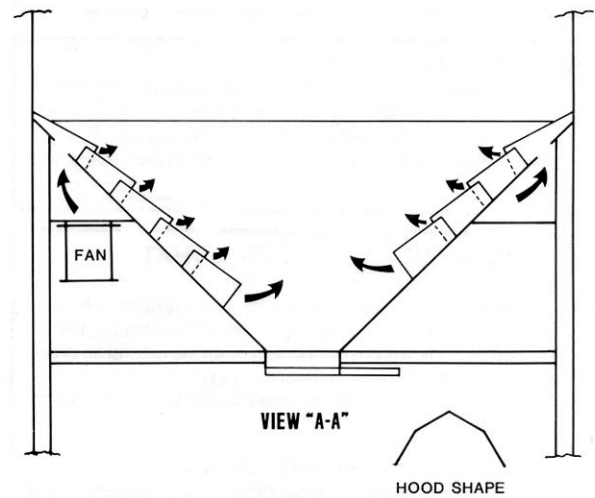
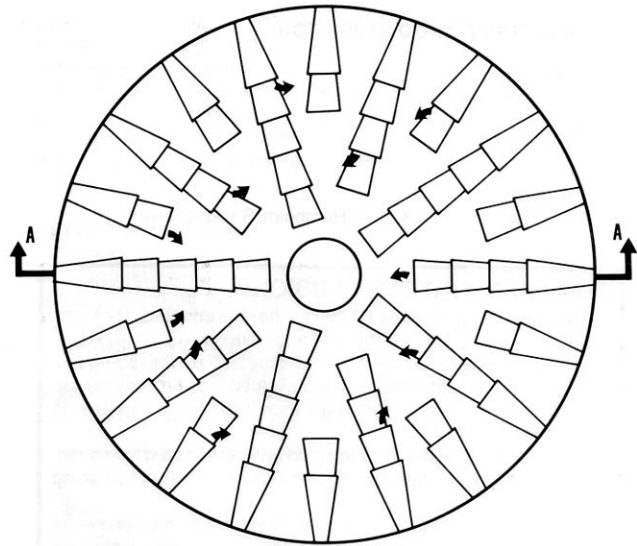

FIGURE 1. Bader Hooded Natural Air Drying System.

### MECHANICAL HISTORY

An extended durability test was not performed. No mechanical problems were encountered during testing. The bin and air distribution system could be epoxy coated for storing fertilizer.

SPECIFICATIONS	
<b>Make:</b>	Bader
<b>Model:</b>	Hooded
<b>Air Distribution System:</b>	
- plenum	
- height	24 in (610 mm)
- base width	28.8 in (730 mm)
- shape	triangular, circling the top of the hopper
- fan mount diameter	18.3 in (460 mm)
plenum holes	
- shape	round
- size	8 in (20 mm)
- number	20
- open area	70 ft <sup>2</sup> (0.65 m <sup>2</sup> )
air distribution ducts	
- ducts per senes	5 at 5 4 at 4 10 at 2
- air/grain interface area	17.1 ft <sup>2</sup> (1.59m <sup>2</sup> )

# GREHI

## MANUFACTURER AND DISTRIBUTOR:

Grehi Mfg. Co Ltd.  
 P.O. Box 756  
 Brandon, Manitoba  
 R7A 5Z8  
 (204) 727-3229

## RETAIL PRICE:

\$735.00. (October 1988, f.o.b. Humboldt, Saskatchewan).

### SUMMARY AND CONCLUSIONS

Average-drying time was 1.10 times the reference bin. Through-drying time was 1.20 times the reference bin.

Airflow rate was 0.80 cfm/bu (10.4 L/s·m<sup>3</sup>) with a typical 3 hp (2.2 kW) fan. Drying uniformity results indicated that parts of the top layer of grain took 6% longer to dry than if airflow uniformity was ideal.

The natural air drying system could be field installed in any bin. Ease of installing the fan/transition unit was fair. Ease of cleaning was poor.

No operator's manual was provided and no mechanical problems were encountered. The system could not be epoxy coated for storing fertilizer.

### RECOMMENDATIONS

It is recommended that the manufacturer consider:

1. Improving ease of installing the fan/transition unit.
2. Providing a safer method for operating the slide gate.
3. Providing natural air guidelines and installation instructions with each system.

### THE MANUFACTURER STATES THAT

With regard to recommendation number:

1. A new transition with a grain/airflow diverter has been developed to eliminate the need for removing the fan when unloading the bin.
2. With experience, it is possible to fully open the natural air drying system slide-gate quickly without running the auger.
3. An operator's manual will be prepared for the 1989 drying season.

### MANUFACTURER'S ADDITIONAL COMMENTS

We feel that the installation time stated in this report is too long. Up to three units have been installed by our crew in an eight hour day.

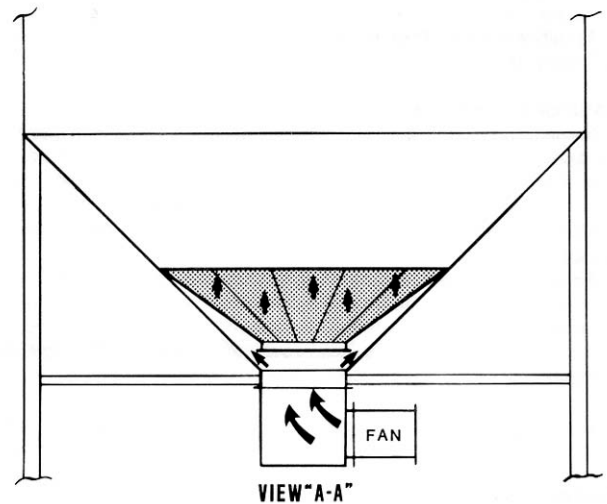
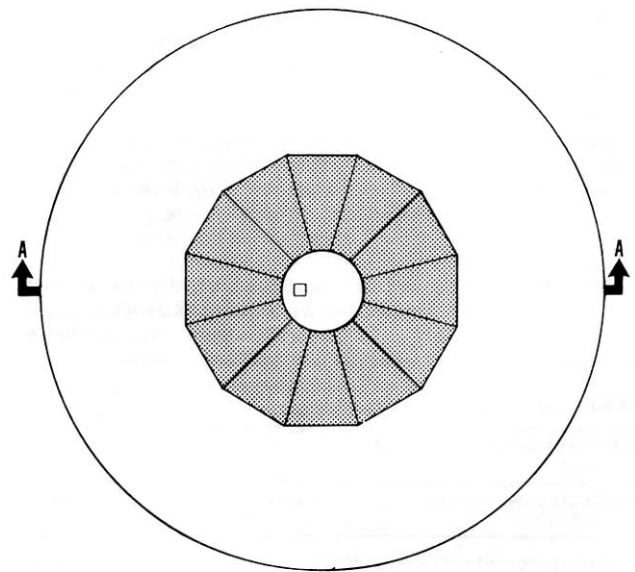

FIGURE 2. Grehi Natural Air Drying System.

The time for the Grehi hopper bin natural air drying system to through-dry a bin of wheat was 1.20 times the reference bin. In drying conditions that would take the reference bin 21 days to reach through-dry, the Grehi would take 25 days.

## GENERAL DESCRIPTION

The Grehi hopper bin natural air drying system consists of several pie-shaped screens assembled at the bottom of the hopper to form a raised perforated floor. Wooden wedges between the screen and the bin hopper support the floor. Air from the fan passes through a right-angle transition, into the open bin slide-gate and under the raised perforated floor, where it is introduced into the grain (FIGURE 2). A second slide-gate, at the bottom of the perforated floor, regulates grain flow during emptying.

## RESULTS AND DISCUSSION

### RATE OF WORK

**Drying Time:** The time for the Grehi hopper bin natural air drying system to average-dry a 14 ft (4.3 m) diameter bin with 1860 bu (67.7 m<sup>3</sup>) of wheat was 1.10 times the reference bin. In drying conditions that would take the reference bin 14 days to reach average-dry, the Grehi would take 15 days.

### QUALITY OF WORK

**Airflow:** Expected airflow rates with three different typical fan sizes are given in TABLE 3. For example, a typical 3 hp (2.2 kW) fan would achieve an airflow rate of 0.80 cfm/bu (10.4 L/s·m<sup>3</sup>). Note that these values will vary if the grain has a different airflow resistance.

TABLE 3. Grehi Airflow Rates in Wheat.

TYPICAL FAN SIZE hp (kW)	1 to 2 (0.75 to 1.5)	3 (2.2)	5 (3.7)
EXPECTED AIRFLOW RATE cfm/bu (L/s·m <sup>3</sup> )	0.55 (7.2)	0.80 (10.4)	0.95 (12.4)

**Drying Uniformity:** Drying uniformity results with the Grehi hopper bin natural air drying system indicated that airflow was higher at the bin edges than in the centre of the bin. This resulted in parts of the top layer taking 6% longer to dry completely than if the airflow uniformity was ideal. The last grain to dry when through dry was at the top centre of the bin.

## EASE OF OPERATION

**Installation:** The Grehi was field installed in a Bader model Bt 412045E bin. The system could be installed in any bin. Installation took two men about eight hours, and was difficult. The screens were difficult to get into the bin, as they were larger than the grain discharge hole. Assembling the screens in the sloped floor of the hopper bin was awkward, and entering the completed unit was difficult. No gasket was provided for the fan transition, so caulking was used. No installation instructions were provided.

Ease of installing the in-line centrifugal fan and transition was fair. All work could be done at ground level, but, reattaching the fan/transition unit to the bin after each unloading was difficult and time-consuming, as the fan had to be blocked and aligned each time. It is recommended that the manufacturer consider improving the ease of installing the fan/transition unit.

**Monitoring:** Monitoring for average-dry was fair and for the through-dry was good.

To determine when average-dry, grain samples had to be collected from many locations in the bin as the drying front was not level. Instead it was lower in the centre. This was inconvenient, but is typical of many natural air drying systems. To determine through-dry, a grain sample could be collected through the grain filler hole as the last grain to dry was at the top centre of the bin.

**Cleaning:** Ease of cleaning was poor. About 10 bu (0.36 m<sup>3</sup>) of grain remained at the bottom of the bin after augering was complete, and was difficult to clean out as access was limited without removing the slide-gate unit, or entering the bin from the top with a chain ladder. The fan and transition had to be removed each time the bin was unloaded, which was inconvenient.

## FAN REQUIREMENTS

Fan requirements in wheat for various airflow rates are given in TABLE 4. For example, to obtain an airflow rate of 1 cfm/bu (13 L/s•m<sup>3</sup>), the fan must be able to deliver an airflow of 1860 cfm (870 L/s) at a static pressure of 8.2 in•wg (2050 Pa). Note that these values will vary if the grain has a different airflow resistance.

TABLE 4. Grehi Fan Requirements in Wheat.

DESIRED AIRFLOW RATE cfm/bu (L/s•m <sup>3</sup> )	0.5 (6.5)	0.75 (9.8)	1.0 (1.3)	1.25 (16.3)	15 (19.5)	
MINIMUM FAN PERFORMANCE	STATIC PRESSURE in•wg (Pa)	3.5 (880)	5.7 (1430)	8.2 (2050)	*	*
	AIRFLOW cfm (L/s)	930 (440)	1400 (660)	1860 (870)	2330 (1100)	2790 (1310)

\*Above 10 in wg (2500 Pa)

## OPERATOR SAFETY

The Grehi slide-gate was difficult and awkward to reach, and presented a safety hazard. The operator had to reach over the top of a running auger into the bottom of the bin to initially open the natural air drying system slide-gate. All subsequent control of grain flow could be done with the bin's slide-gate. It is recommended that the manufacturer provide a safer method for opening the slide-gate.

The screws used to attach the top of the screens to the bin protruded through the bin floor. These screw tips were a hazard to anyone working around the bin.

## OPERATOR'S MANUAL

No operator's manual was provided. It is recommended that the manufacturer provide natural air drying guidelines and installation instructions with each system.

## MECHANICAL HISTORY

An extended durability test was not performed. No mechanical problems were encountered during testing. The air distribution system could not be epoxy coated for storing fertilizer.

SPECIFICATIONS	
<b>Make:</b>	Grehi
<b>Air Distribution System:</b>	
- air transfer to grain	louvred screen
- porosity	5.4 holes/in <sup>2</sup> (0.84 holes/cm <sup>2</sup> )
- hole shape	oval
- hole size	0.43 x 0.078 in (11 x 2 mm)
- air/grain interface area	593 ft <sup>2</sup> (55 m <sup>2</sup> )
<b>Transition:</b>	
- description	right angle
- inlet diameter	17.5 in (440 mm)
- outlet diameter	17.5 in (440 mm)
- size	20 x 20 x 20 in (510 x 510 x 510 mm)

# HARVEST HOPPER

## MANUFACTURER AND DISTRIBUTOR:

Saskatoon Oilfield Manufacturing Ltd.  
P.O. Box 9600  
Saskatoon, Saskatchewan  
S7K 7G1  
(306) 492-4848

## RETAIL PRICE:

\$600.00, (October 1988, f.o.b. Humboldt. Saskatchewan.)

### SUMMARY AND CONCLUSIONS

Average-drying time was 1.00 times the reference bin. Through-drying time was 1.30 times the reference bin.

Airflow rate was 0.85 cfm/bu (11.1 L/s•m<sup>3</sup>) with a typical 3 hp (2.2 kW) fan. Drying uniformity tests indicated that parts of the top layer of grain took 35% longer to dry than if airflow uniformity was ideal.

The natural air drying system could be factory installed in Harvest Hopperbins, but could not be field installed. Ease of installing the fan was very good. Ease of cleaning was very good.

No operator's manual was provided and no mechanical problems were encountered. The system could be epoxy coated for storing fertilizer.

### RECOMMENDATIONS

It is recommended that the manufacturer consider:

1. Providing natural air guidelines with each system.

### THE MANUFACTURER STATES THAT

With regard to recommendation number:

1. Operating procedures on natural air drying can be determined from pamphlets available from the Departments of Agriculture in both Saskatchewan and Manitoba.

## GENERAL DESCRIPTION

The Harvest Hopper bin natural air drying system uses the area below the interior welded hopper as a plenum. Air is blown into this plenum through a ground level flange mount. Air is introduced into the grain through 60 triangular hooded holes (FIGURE 3).

## RESULTS AND DISCUSSION

### RATE OF WORK

**Drying Time:** The time, for the Harvest Hopper hopper bin natural air drying system to average-dry a 15.5 ft (4.7 m) diameter bin with 1960 bu (71.3 m<sup>3</sup>) of wheat was 1.00 times the reference bin. In drying conditions that would take the reference bin 14 days to reach average-dry, the Harvest Hopper would also take 14 days.

The time for the Harvest Hopper hopper bin natural air drying system to through-dry a bin of wheat was 1.30 times the reference bin. In drying conditions that would take the reference bin 21 days to reach through-dry, the Harvest Hopper would take 27 days.

### QUALITY OF WORK

**Airflow:** Expected airflow rates with three different typical fan sizes are given in TABLE 5. For example, a typical 3 hp (2.2 kW) fan would achieve an airflow rate of 0.85 cfm/bu (11.1 L/s•m<sup>3</sup>). Note that these values will vary if the grain has a different airflow resistance.

TABLE 5. Harvest Hopper Airflow Rates in Wheat.

TYPICAL FAN SIZE hp (kW)	1 to 2 (0.75 to 1.5)	3(2)	5 (3.7)
EXPECTED AIRFLOW RATE cfm/bu (L/s•m <sup>3</sup> )	0.60 (7.8)	0.85 (11.1)	1.00 (13.0)

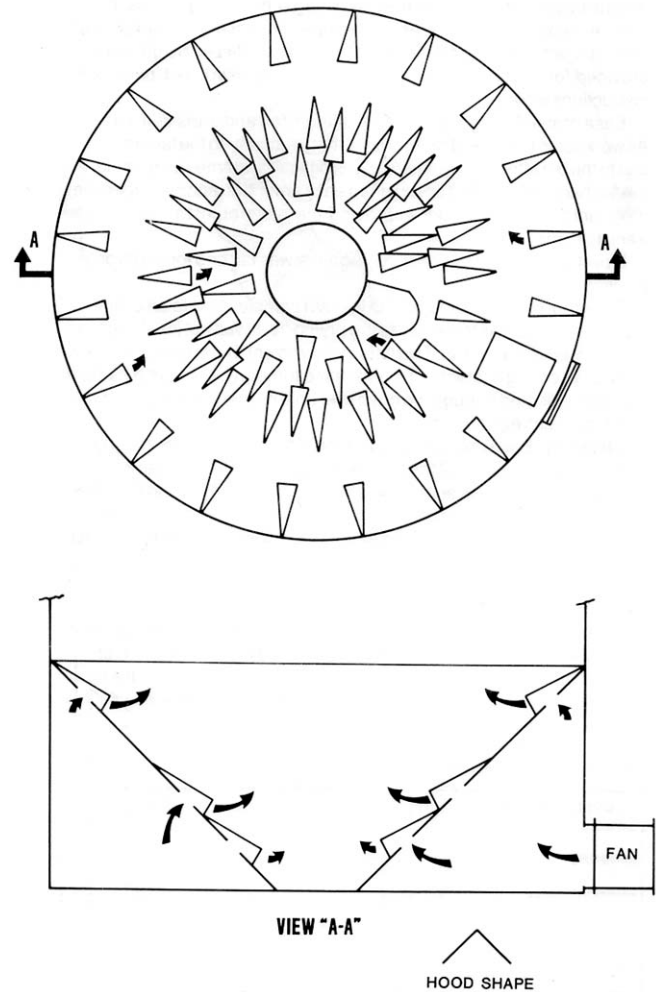

FIGURE 3. Harvest Hopper Natural Air Drying System.

**Drying Uniformity:** Drying uniformity results with the Harvest Hopper hopper bin natural air drying system indicated that airflow was higher at the bin edges than in the centre of the bin. This resulted in parts of the top layer taking 35% longer to dry completely than if the airflow uniformity was ideal. The last gram to dry when through-dry was at the top centre of the bin.

### EASE OF OPERATION

**Installation:** The Harvest Hopper was factory installed in a Harvest Hopper Model 69 Tonne bin. The system could be factory installed in other sizes of Harvest Hopper bins, but cannot be used in other makes of hopper bins. Ease of installing the in-line centrifugal fan was very good, as all work could be done at ground level.

**Monitoring:** Monitoring for average-dry was fair and for through-dry was good.

To determine when average dry, grain samples had to be collected from many locations in the bin as the drying front was not level. Instead, it was lower in the centre of the bin. This was inconvenient, but is typical of many natural air drying systems. To determine through-dry, a grain sample could be collected through the grain filter hole as the last grain to dry was at the top centre of the bin.

**Cleaning:** Ease of cleaning was very good. The natural air drying system did not affect bin unloading. However, there was about 30 bu (1.1 m) of grain left in the bin that had to be shoveled into the auger. Cleaning this grain was inconvenient as bin access was restricted by the auger in the doorway.

**FAN REQUIREMENTS**

Fan requirements in wheat for various airflow rates are given in TABLE 6. For example, to obtain an airflow rate of 1 cfm/bu (13 L/s•m<sup>3</sup>), the fan must be able to deliver an airflow of 1960 cfm (920 L/s) at a static pressure of 7.5 in•wg (1880 Pa). Note that these values will vary if the grain has a different airflow resistance.

**TABLE 6.** Harvest Hopper Fan Requirements in Wheat.

DESIRED AIRFLOW RATE cfm/bu (L/s•m <sup>3</sup> )		0.5 (6.5)	0.75 (9.8)	1.0 (1.3)	1.25 (16.3)	1.5 (19.5)
MINIMUM FAN PERFORMANCE	STATIC PRESSURE in•wg (Pa)	28 (700)	5.0 (1250)	7.5 (1880)		
	AIRFLOW cfm (L/s)	980 (460)	1470 (690)	1960 (920)	2450 (1150)	2940 (1380)
*Above 10 in•wg (2500 Pa)						

**OPERATOR SAFETY**

No safety hazards were apparent when normal precautions were observed.

**OPERATOR'S MANUAL**

No operator's manual was provided. It is recommended that the manufacturer provide natural air drying guidelines with each system.

**MECHANICAL HISTORY**

An extended durability test was not performed. No mechanical problems were encountered during testing. The bin and air distribution system could be epoxy coated for storing fertilizer.

SPECIFICATIONS	
<b>Make:</b>	Harvest Hopper
<b>Air Distribution System:</b>	
- duct inlet size	7 in (178 mm) high x 55 in (140 mm) wide triangular
- duct inlet shape	
- duct outlet size	43 at 3.5 in (89 mm) high x 7 in (178 mm) wide 17 at 35 in (89 mm) high x 9.8 in (248 mm) wide
- duct location in hopper	17 top, 18 middle, 8 bottom, 17 between bottom and middle
- air/grain interface area	5.7 ft <sup>2</sup> (0.53 m <sup>2</sup> )
- fan inlet size	18 in (457 mm) diameter

# TRAIL RITE V AERATION

## MANUFACTURER AND DISTRIBUTOR:

Trail Rite Ltd.  
P.O. Box 1718  
Tisdale, Saskatchewan  
S0E 1T0  
1-800-667-5020

## RETAIL PRICE:

\$748.00, (October 1988, f.o.b. Humboldt, Saskatchewan.)

### SUMMARY AND CONCLUSIONS

Average-drying time was 1.20 times the reference bin. Through-drying time was 1.10 times the reference bin.

Airflow rate was 1.00 cfm/bu (13.0 L/s•m<sup>3</sup>) with a typical 3 hp (2.2 kW) fan. Drying uniformity results indicated that parts of the top layer of grain took 16% longer to dry than if airflow uniformity was ideal.

The natural air drying system could be field installed in some bins. Ease of installing the fan was good. Ease of cleaning was very good.

No operator's manual was provided and no mechanical problems were encountered. The system could be epoxy coated for storing fertilizer.

### RECOMMENDATIONS

It is recommended that the manufacturer consider:

1. Modifying the duct to prevent grain from entering during operation.
2. Providing natural air guidelines with each system.

### THE MANUFACTURER STATES THAT

With regard to recommendation number:

1. The duct has been modified to reduce this problem.
2. Installation instructions are provided. Also, operating procedures on natural air drying can be determined from pamphlets available from the Department of Agriculture in both Saskatchewan and Manitoba.

### GENERAL DESCRIPTION

The Trail Rite V Aeration hopper bin natural air drying system consists of an inverted "V" duct positioned horizontally at the top of the hopper. An additional inverted "V" duct is on top of the base duct. Rectangular holes cut into the peak of the base duct allow air into the top duct (FIGURE 4).

### RESULTS AND DISCUSSION

#### RATE OF WORK

**Drying Time:** The time for the Trail Rite V Aeration hopper bin natural air drying system to average-dry a 16 ft (4.9 m) diameter bin with 1840 bu (66.9 m<sup>3</sup>) of wheat was 1.20 times the reference bin. In drying conditions that would take the reference bin 14 days to reach average-dry, the Trail Rite V Aeration would take 17 days.

The time for the Trail Rite V Aeration hopper bin natural air drying system to through-dry a bin of wheat was 1.10 times the reference bin. In drying conditions that would take the reference bin 21 days to reach through dry, the Trail Rite V Aeration would take 23 days.

#### QUALITY OF WORK

**Airflow:** Expected airflow rates with three different typical fan sizes are given in TABLE 7. For example, a typical 3 hp (2.2 kW) fan would achieve an airflow rate of 1.00 cfm/bu (13.0 L/s•m<sup>3</sup>). Note that these values will vary if the grain has a different airflow resistance.

The duct filled with wheat during operation, but this did not affect airflow rate or drying performance. It is recommended that the manufacturer consider modifications to prevent grain from entering the duct.

**Drying Uniformity:** Drying uniformity results with the Trail Rite V Aeration hopper bin natural air drying system indicated that airflow was higher at the bin edges than in the centre of the bin. This resulted in parts of the top layer taking 16% longer to dry completely than if the airflow

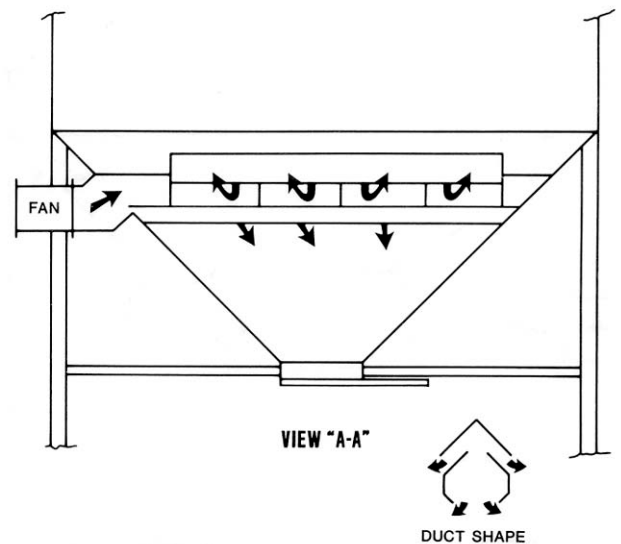
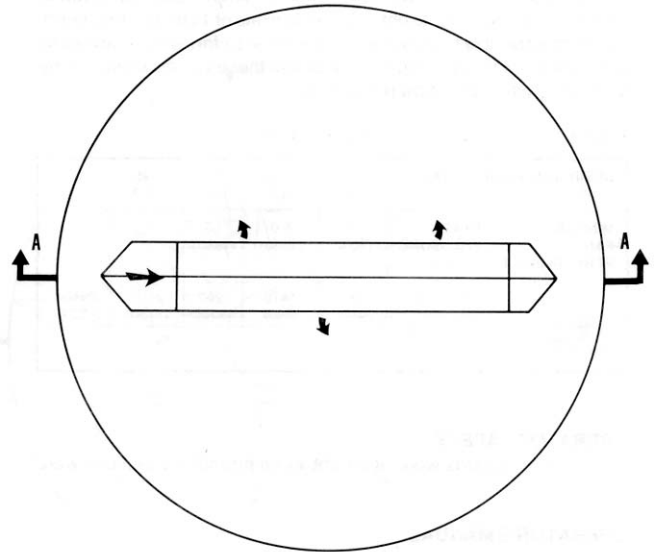

FIGURE 4. Trail Rite V Aeration Natural Air Drying System

uniformity was ideal. The last grain to dry when through-dry was at the top centre of the bin.

TABLE 7. Trail Rite V Aeration Airflow Rates in Wheat.

TYPICAL FAN SIZE hp (kW)	1 to 2 (0.75 to 1.5)	3 (2.2)	5 (3.7)
EXPECTED AIRFLOW RATE cfm/bu (L/s•m <sup>3</sup> )	0.70 (9.1)	1.00 (13.0)	1.20 (15.6)

#### EASE OF OPERATION

**Installation:** The Trail Rite V Aeration was factory installed in a Trail Rite Model FB73 bin. The system could be field installed in any bin with a 40° hopper slope. Ease of installing the in line centrifugal fan was good, as the fan had to be lifted to chest height.

**Monitoring:** Monitoring for average-dry was fair and for through-dry was good.

To determine when average dry grain samples had to be collected from many locations in the bin as the drying front was not level. Instead it formed a hump above the duct. This was inconvenient, but is typical of many natural air drying systems. To determine through-dry, a grain sample could be collected through the grain filler hole as the last grain to dry was at the top centre of the bin.



**Cleaning:** Ease of cleaning was very good. The natural air drying system did not affect bin unloading.

**FAN REQUIREMENTS**

Fan requirements in wheat for various airflow rates are given in TABLE 8. For example, to obtain an airflow rate of 1 cfm/bu (13 L/s•m<sup>3</sup>), the fan must be able to deliver an airflow of 1840 cfm (860 L/s) at a static pressure of 5.7 in•wg (1430 Pa). Note that these values will vary if the grain has a different airflow resistance.

**TABLE 8.** Trail Rate V-Aeration Fan Requirements in Wheat.

DESIRED AIRFLOW RATE cfm/bu (L/s•m <sup>3</sup> )		0.5 (6.5)	0.75 (9.8)	1.0 (.13)	1.25 (16.3)	1.5 (19.5)
<b>MINIMUM FAN PERFORMANCE</b>	<b>STATIC PRESSURE</b> in•wg (Pa)	2.1 (530)	3.7 (930)	5.7 (1430)	7.9 (1980)	*
	<b>AIRFLOW</b> cfm (L/s)	920 (430)	1380 (650)	1840 (860)	2300 (1080)	2750 (1290)

\* Above 10 in•wg (2500 Pa)

**OPERATOR SAFETY**

No safety hazards were apparent when normal precautions were observed.

**OPERATOR'S MANUAL**

No operator's manual was provided. It is recommended that the manufacturer provide natural air drying guidelines with each system.

**MECHANICAL HISTORY**

An extended durability test was not performed. No mechanical problems were encountered during testing. The bin and air distribution system could be epoxy coated for storing fertilizer.

SPECIFICATIONS	
<b>Make:</b>	Trail Rite
<b>Model:</b>	V-Aeration
<b>Air Distribution System:</b>	
- bottom duct total length	11.7 ft (3.56 m)
- top duct total length	8.3 ft (2.52 m)
- air grain interface area	13.8 ft <sup>2</sup> (1.28 m <sup>2</sup> )
<b>Transition:</b>	
- inlet diameter	18 in (457 mm)
- outlet size	18 in (457 mm)
- length	137 in (1350 mm)

# UNIVISION IN-LINE

## MANUFACTURER AND DISTRIBUTOR:

Univision industries Ltd.  
P.O. Box 2139  
Humboldt, Saskatchewan  
S0K 2A0  
(306) 682-3372

## RETAIL PRICE:

\$440.00, (October 1988, f.o.b. Humboldt, Saskatchewan.)

### SUMMARY AND CONCLUSIONS

Average-drying time was 0.90 times the reference bin. Through-drying time was also 0.90 times the reference bin.

Airflow rate was 1.10 cfm/bu (14.3 L/s•m<sup>3</sup>) with a typical 3 hp (2.2 kW) fan. Drying uniformity tests indicated that parts of the top layer of grain took 17% longer to dry than if airflow uniformity was ideal.

The natural airdrying system could be field installed in some bins. Ease of installing the fan was fair. Ease of cleaning was very good.

No operator's manual was provided and no mechanical problems were encountered. The system could be removed for storing fertilizer.

### RECOMMENDATIONS:

It is recommended that the manufacturer consider:

1. Providing natural air guidelines with each system.

### THE MANUFACTURER STATES THAT

With regard to recommendation number:

1. Installation instructions are provided. Also, operating procedures on natural air drying can be determined from pamphlets available from the Departments of Agriculture in both Saskatchewan and Manitoba.

## GENERAL DESCRIPTION

The Univision In-Line hopper bin natural air drying system consists of a corrugated cylindrical perforated screen positioned horizontally near the top of the hopper of the bin. A round transition enters the side of the hopper to direct air from the fan to the air distribution system (FIGURE 5).

## RESULTS AND DISCUSSION

### RATE OF WORK

**Drying Time:** The time for the Univision In-Line hopper bin natural air drying system to average-dry a 16 ft (4.9 m) diameter bin with 1940 bu (70.6 m<sup>3</sup>) of wheat was 0.90 times the reference bin in drying conditions that would take the reference bin 14 days to reach average-dry, the Univision in-Line would take 13 days.

The time for the Univision In-Line hopper bin natural air drying system to th rough-dry a bin of wheat was 0.90 times the reference bin. In drying conditions that would take the reference bin 21 days to reach through-dry, the Univision In-Line would take 19 days.

### QUALITY OF WORK

**Airflow:** Expected airflow rates with three different typical fan sizes are given in TABLE 9. For example, a typical 3 hp (2.2 kW) fan would achieve an airflow rate of 1.10 cfm/bu (14.3 L/s•m<sup>3</sup>). Note that these values will vary if the grain has a different airflow resistance.

Table 9. Univision In-Line Airflow Rates in Wheat.

TYPICAL FAN SIZE hp (kW)	1 to 2 (0.75 to 1.5)	3 (2.2)	5 (3.7)
EXPECTED AIRFLOW RATE cfm/bu (L/s•m <sup>3</sup> )	0.75 (9.8)	1.10 (14.3)	1.35 (17.6)

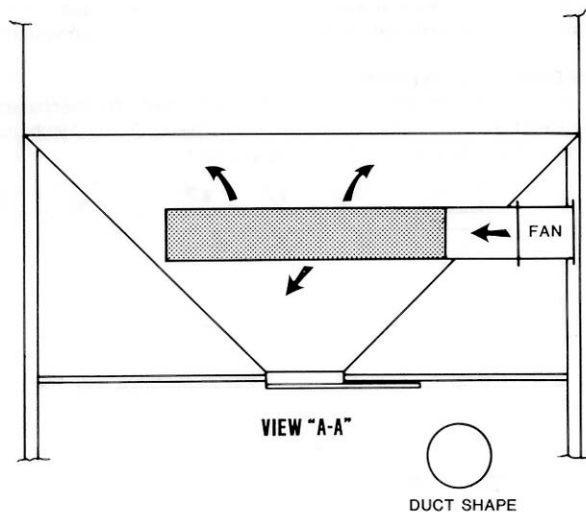
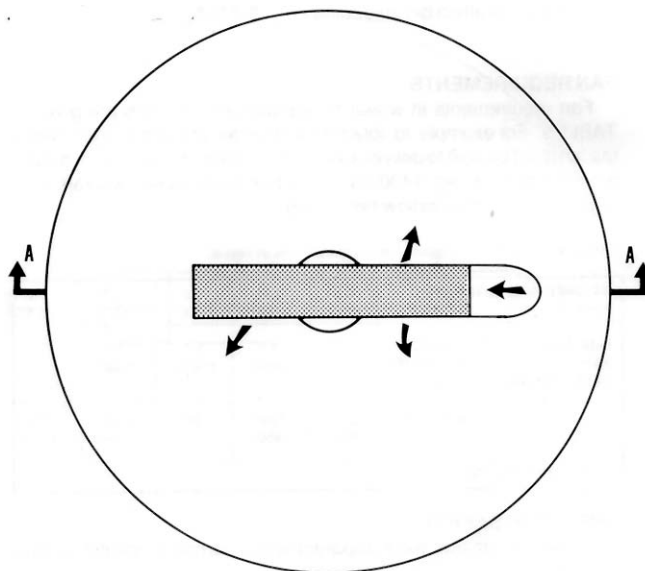

FIGURE 5. Univision In-Line Natural Air Drying System.

**Drying Uniformity:** Drying uniformity results with the Univision In-Line hopper bin natural air drying system indicated that airflow was higher at the bin edges than in the centre of the bin. This resulted in parts of the top layer taking 17% longer to dry completely than if the airflow uniformity was ideal. The last grain to dry when through-dry was at the top centre of the bin.

### EASE OF OPERATION

**Installation:** The Univision In-Line was factory installed in a Univision Model UB 1608 bin. The screen could be field installed in five minutes in any bin that had the supports and air inlet previously installed. Ease of installing the in-line centrifugal fan was fair, as the fan had to be lifted above shoulder height.

**Monitoring:** Monitoring for average-dry was fair and for through-dry was good.

To determine when average-dry, grain samples had to be collected from many locations in the bin as the drying front was not level. Instead it formed a hump above the duct. This was inconvenient, but is typical of many natural air drying systems. To determine through dry, a grain sample could be collected through the grain filler hole as the last gram to dry was at the top centre of the bin.

**Cleaning:** Ease of cleaning was very good. The natural air drying system did not affect bin unloading, but some grain remained on top of the duct after emptying.

## FAN REQUIREMENTS

Fan requirements in wheat for various airflow rates are given in TABLE 10. For example, to obtain an airflow rate of 1 cfm/bu (13 L/s•m<sup>3</sup>). The fan must be able to deliver an airflow of 1940 cfm (910 L/s) at a static pressure of 4.5 in•wg (1130 Pa). Note that these values will vary if the grain has a different airflow resistance.

TABLE 10. Univision In Line Fan Requirements in Wheat.

DESIRED AIRFLOW RATE cfm/bu (L/s•m <sup>3</sup> )		0.5 (6.5)	0.75 (9.8)	1.0 (13)	1.25 (16.3)	1.5 (19.5)
MINIMUM FAN PERFORMANCE	STATIC PRESSURE in•wg (Pa)	1.7 (430)	3.0 (750)	4.5 (1130)	6.0 (1500)	7.8 (1950)
	AIRFLOW cfm (L/s)	970 (460)	1450 (680)	1940 (910)	2420 (1140)	2910 (1370)

## OPERATOR SAFETY

No safety hazards were apparent when normal precautions were observed.

## OPERATOR'S MANUAL

No operator's manual was provided. It is recommended that the manufacturer provide natural air drying guidelines with each system.

## MECHANICAL HISTORY

An extended durability test was not performed. No mechanical problems were encountered during testing. The air distribution system had to be removed for storing fertilizer. This involved removing the fan, pulling the duct out through the transition, and covering the fan inlet.

SPECIFICATIONS	
<b>Make:</b>	Univision
<b>Model:</b>	In-Line
<b>Air Distribution System:</b>	perforated screen
- air transfer to grain	77 ft (23 m)
- length	17in (432 mm)
- diameter	34.1 ft <sup>2</sup> (3.17m <sup>2</sup> )
- air gram interface area	70 holes/in <sup>2</sup> (10.9 holes cm <sup>2</sup> )
- porosity	0.063 in (16 mm)
- hole size	
<b>Transition:</b>	
- inlet diameter	18.1 in (460 mm)
- outlet diameter	18.1 in (460 mm)
- length	36.6 in (930 mm)

# UNIVISION ULTRA-DRY

## MANUFACTURER AND DISTRIBUTOR:

Univision Industries  
P.O. Box 2139  
Humboldt, Saskatchewan  
S0K 2A0  
(306) 682-3372

## RETAIL PRICE:

\$1200.00. (October 1988, f.o.b. Humboldt. Saskatchewan.)

### SUMMARY AND CONCLUSIONS

Average-drying time was 0.70 times the reference bin. Through-drying time was 0.90 times the reference bin.

Airflow rate was 1.15 cfm/bu (15.0 L/s•m<sup>3</sup>) with a typical 3 hp (2.2 kW) fan. Drying uniformity results indicated that parts of the outside layer of grain took 33% longer to dry than if airflow uniformity was ideal.

The natural air drying system could be factory installed in Univision bins, but could not be field installed. Ease of installing the fan was good. Ease of cleaning was good. Some grain remained in the bin when the initial grain moisture content was above 20%.

No operator's manual was provided and no mechanical problems were encountered. The system could be epoxy coated for storing fertilizer.

### RECOMMENDATIONS

It is recommended that the manufacturer consider:

1. Providing natural air guidelines with each system.

### THE MANUFACTURER STATES THAT

With regard to recommendation number:

1. Operating procedures on natural air drying can be determined from pamphlets available from the Departments of Agriculture in both Saskatchewan and Manitoba.

### MANUFACTURER'S ADDITIONAL COMMENTS

The welded eave rings are now made using a louvered screen to ensure that grain with an initial moisture content above 20% does not remain on top of the rings.

## GENERAL DESCRIPTION

The Univision Ultra-Dry hopper bin natural air drying system consists of a cylindrical louvered screen positioned vertically at the bottom centre of the bin. Air from the fan passes through a rectangular transition in the side of the hopper and into the air distribution system. Four welded eave rings on the interior of the bin wall allow air to move from the grain to vertical ducts which exhaust to the outside above each bin leg. A small amount of air exhausted through the bin lid vent, as the lid was closed during operation. The configuration is shown in FIGURE 6.

## RESULTS AND DISCUSSION

### RATE OF WORK

**Drying Time:** The time for the Univision Ultra-Dry hopper bin natural air drying system to average-dry a 16 ft (4.4 m) diameter bin with 1940 bu (70.6 m<sup>3</sup>) of wheat was 0.70 times the reference bin. In drying conditions that would take the reference bin 14 days to reach average-dry, the Univision UltraDry would take 10 days.

The time for the Univision Ultra-Dry hopper bin natural air drying system to through-dry a bin of wheat was 0.90 times the reference bin. In drying conditions that would take the reference bin 21 days to reach through-dry, the Univision Ultra Dry would take 19 days.

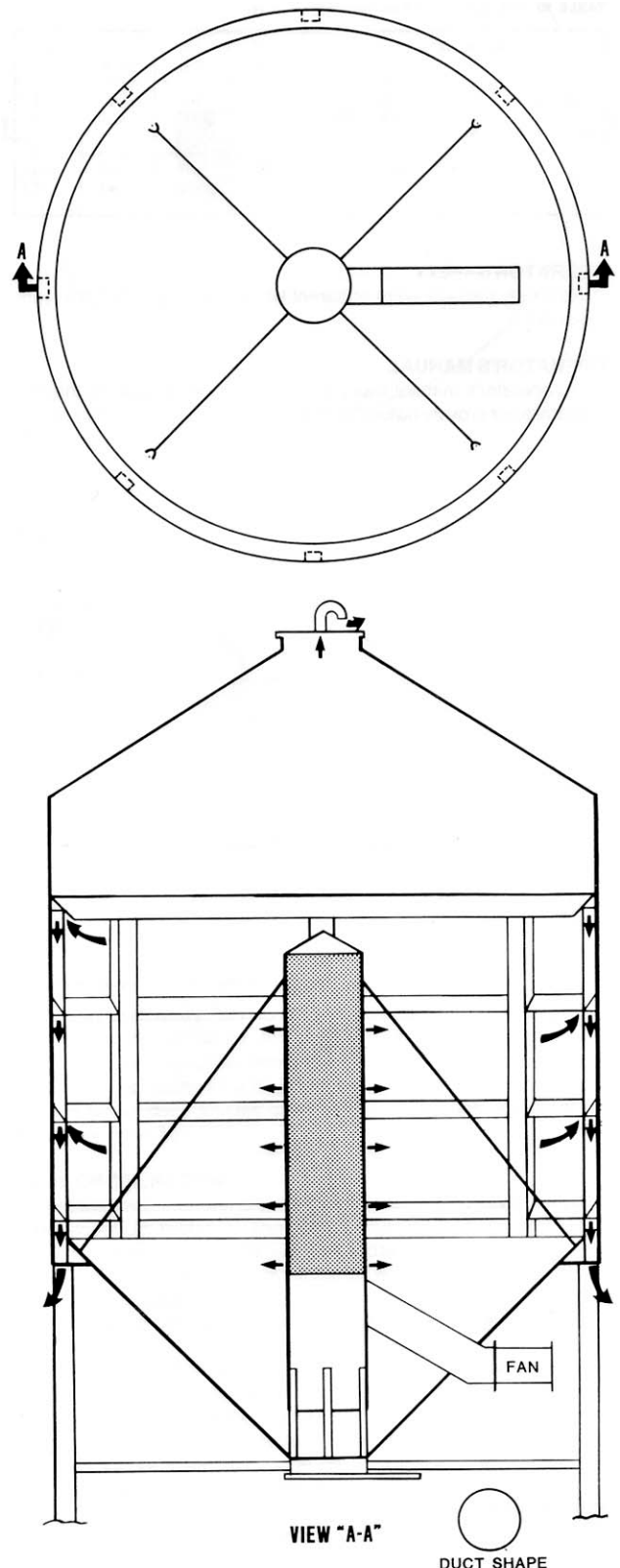

FIGURE 6. Univision Ultra-Dry Natural Air Drying System.

## QUALITY OF WORK

**Airflow:** Expected airflow rates with three different typical fan sizes are given in TABLE 11. For example, a typical 3 hp (2.2 kW) fan would achieve an airflow rate of 1.15 cfm/bu (15.0 L/s•m³). Note that these values will vary if the grain has a different airflow resistance.

**TABLE 11.** Univision Ultra-Dry Airflow Rates in Wheat.

TYPICAL FAN SIZE hp (kW)	1 to 2 (0.75 to 1.5)	3 (2.2)	5 (3.7)
EXPECTED AIRFLOW RATE cfm/bu (L/s•m³)	0.80 (104)	1.15 (15.0)	1.40 (18.2)

**Drying Uniformity:** Drying uniformity results with the Univision Ultra-Dry hopper bin natural air drying system indicated that airflow was higher at the bottom of the bin walls and the top centre of the bin than at the top of the bin near the eave. This resulted in parts of the outside layer taking 33% longer to dry completely than if the airflow uniformity was ideal. The last grain to dry when through-dry was at the top edge of the bin near the eave.

## EASE OF OPERATION

**Installation:** The Univision Ultra-Dry was factory installed in a Univision Model UB1608 bin. The system could not be field installed in other bins. Ease of installing the in-line centrifugal fan was good. The fan had to be lifted to chest height and had to be mounted at an angle to avoid interference between the fan and the horizontal leg supports.

**Monitoring:** Monitoring for average-dry was fair and for the through-dry was good.

To determine when average-dry, grain samples had to be collected from many locations in the bin as the drying front was not level. Instead it formed a hump above the duct. This was inconvenient, but is typical of many natural air drying systems. To determine through-dry, a grain sample could be collected through the inspection hole near the roof ladder as the last grain to dry was near the eave of the bin.

The Univision Ultra-Dry operated with the bin lid closed which could be an advantage if rain occurs during drying.

**Cleaning:** Ease of cleaning was good. The natural air drying system did not normally affect bin unloading. However, when the initial grain moisture content exceeded 20%, a small amount of grain remained on top of the eave rings after unloading. This was difficult to remove.

## FAN REQUIREMENTS

Fan requirements in wheat for various airflow rates are given in TABLE 12. For example, to obtain an airflow rate of 1 cfm/bu (13 L/s•m³), the fan must be able to deliver an airflow of 1940 cfm (910 L/s) at a static pressure of 3.8 in•wg (950 Pa). Note that these values will vary if the grain has a different airflow resistance.

**TABLE 12.** Univision Ultra-Dry Fan Requirements in Wheat.

DESIRED AIRFLOW cfm/bu (L/s•m³)	RATE	0.5 (6.5)	0.75 (9.8)	1.0 (13)	1.25 (16.3)	1.5 (19.5)
MINIMUM FAN PERFORMANCE	STATIC PRESSURE in•wg (Pa)	13 (330)	25 (630)	3.8 (950)	5.4 (1350)	7.1 (1780)
	AIRFLOW cfm (L/s)	970 (460)	1450 (680)	1940 (910)	2420 (1140)	2900 (1360)

## OPERATOR SAFETY

No safety hazards were apparent when normal precautions were observed.

## OPERATOR'S MANUAL

No operator's manual was provided. It is recommended that the manufacturer provide natural air drying guidelines with each system.

## MECHANICAL HISTORY

An extended durability test was not performed. No mechanical problems were encountered during testing. The bin and air distribution system could be epoxy coated for storing fertilizer.

SPECIFICATIONS	
<b>Make:</b>	Univision
<b>Model:</b>	Ultra Dry
<b>Air Distribution System:</b>	
- air transfer to grain	louved screen
- height	108 ft (3.29 m)
- diameter	205 in (520 mm)
- porosity	5.5 holes/in² (0.85 holes/cm²)
- hole size	0.059 x 0.27 in (1.5 x 7 mm)
- hole shape	oval
- air/grain interface area	394 ft² (3.66 m²)
<b>Air Exhaust System:</b>	
- number of rings	4
- ring bottom open width	3 in (76 mm)
- air grain interface area	495 ft² (4.6 m²)
<b>Transition:</b>	
- inlet diameter	179 in (450 mm)
- outlet size	9.3 x 14 in (240 x 360 mm)
- length	4.1 ft (1.24 m)

# WESTEEL BOOT

## MANUFACTURER AND DISTRIBUTOR:

Westeel. A Division of Jannock Steel Fabricating Company Limited  
 450 Desautels  
 P.O. Box 792  
 Winnipeg, Manitoba  
 R3C 2N5  
 (204) 233-7133

## RETAIL PRICE:

\$230.00. (October 1988, f.o.b. Humboldt, Saskatchewan)

### SUMMARY AND CONCLUSIONS

Average-drying time was 1.00 times the reference bin. Through-drying time was 1.20 times the reference bin.

Airflow rate was 0.85 cfm/bu (11.1 L/s•m<sup>3</sup>) with a typical 3 hp (2.2 kW) fan. Drying uniformity results indicated that parts of the top layer of grain took 26% longer to dry than if airflow uniformity was ideal.

The natural air drying system could be field installed in bins with a Westeel Boot. Ease of installing the fan was very good. Ease of cleaning was very good.

No operator's manual was provided and no mechanical problems were encountered.

### RECOMMENDATIONS

It is recommended that the manufacturer consider:

1. Modifying the door to provide adequate sealing.
2. Providing natural air guidelines with each system.

### THE MANUFACTURER STATES THAT

With regard to recommendation number:

1. The door has been redesigned to provide a complete seal.
2. Natural air drying guidelines will be provided at a future date.

### MANUFACTURER'S ADDITIONAL COMMENTS

A "grain skirt" that bolts onto the bin/boot joint is being designed to close off this area and eliminate grain hangup.

## GENERAL DESCRIPTION

The Westeel Boot hopper bin natural air drying system consists of three half-cylindrical screens. Air from the fan enters a plenum which is the area below the interior welded hopper. The air is then introduced into the grain through the three half-cylindrical screens which are positioned as shown in FIGURE 7.

## RESULTS AND DISCUSSION

### RATE OF WORK

**Drying Time:** The time for the Westeel Boot hopper bin natural air drying system to average-dry a 13.9 ft (4.2 m) diameter bin with 2200 bu (80 m<sup>3</sup>) of wheat was 1.00 times the reference bin. In drying conditions that would take the reference bin 14 days to reach average-dry, the Westeel Boot would also take 14 days.

The time for the Westeel Boot hopper bin natural air drying system to through-dry a bin of wheat was 1.20 times the reference bin. In drying conditions that would take the reference bin 21 days to reach through-dry. The Westeel Boot would take 25 days

### QUALITY OF WORK

**Airflow:** Expected airflow rates with three different typical fan sizes are given in TABLE 13. For example, a typical 3 hp (2.2 kW) fan would achieve an airflow rate of 0.85 cfm/bu (11.1 L/s•m<sup>3</sup>) Note that these values will vary if the grain has a different airflow resistance

**Drying Uniformity:** Drying uniformity results with the Westeel Boot hopper bin natural air drying system indicated that airflow was higher above the screens than between the screens. This resulted in parts of the top layer taking 26% longer to dry completely than if the airflow

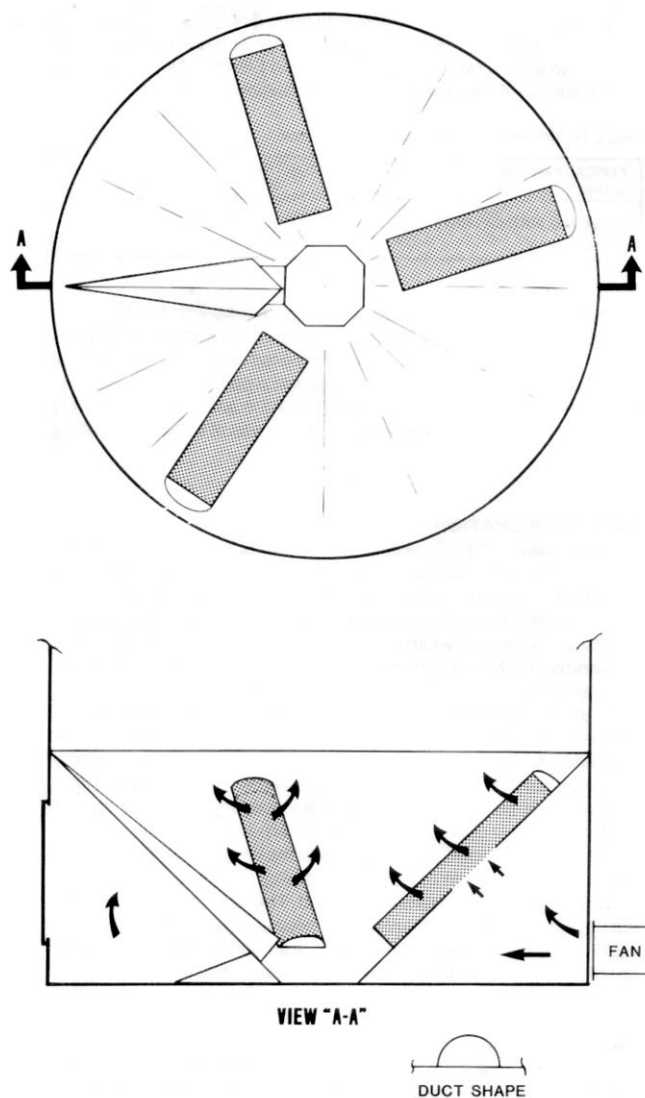

FIGURE 7. Westeel Coot Natural Air Drying System

uniformity was ideal. The last grain to dry when through-dry was at the top centre of the bin.

TABLE 13. Westeel Boot Airflow Rates in Wheat.

TYPICAL FAN SIZE hp (kW)	1 to 2 (0.75 to 1.51)	3 (2.2)	5 (3.7)
EXPECTED AIRFLOW RATE cfm/bu (L/s•m <sup>3</sup> )	0.60 (7.8)	0.85 (11.1)	1.05 (13.7)

### EASE OF OPERATION

**Installation:** The Westeel Boot is factory prepared for installation of the natural air drying system. The system can be either dealer installed before delivery or field installed at a later date. Ease of installing the in-line centrifugal fan was very good, as all work could be done at ground level. No door gasket was provided and the door did not seal adequately when a gasket was installed. It is recommended that the manufacturer consider modifying the door to provide adequate sealing.

**Monitoring:** Monitoring for average dry was fair and for the through dry was good.

To determine when average dry, gram samples had to be collected from many locations in the bin as the drying front was not level. Instead it was higher directly above the screens. This was inconvenient, but is typical of many natural air drying systems to determine through-dry.

a grain sample could be collected through the grain filler hole as the last grain to dry was at the top centre of the bin. Optional bin ladders were available to permit convenient access to the top of the bin.

Cleaning: Ease of cleaning was very good. The natural air drying system did not affect bin unloading. However, there was about 50 bu (1.8 m<sup>3</sup>) of grain left in the boot that had to be shoveled into the auger. Bin access was restricted by the auger in the doorway. Also, a little grain was caught in the joint between the bin wall and the boot, and was very difficult to remove.

**FAN REQUIREMENTS**

Fan requirements in wheat for various airflow rates are given in TABLE 14. For example, to obtain an airflow rate of 1 cfm/bu (1.3 L/s•m<sup>3</sup>), the fan must be able to deliver an airflow of 2200 cfm (1030 L/s) at a static pressure of 6.7 in•wg (1680 Pa). Note that these values will vary if the grain has a different airflow resistance.

TABLE 14. Westeel Boot Fan Requirements in Wheat.

DESIRED AIRFLOW RATE cfm/bu (L/s•m <sup>3</sup> )		0.5 (.65)	0.75 (.98)	1.0 (1.3)	1.25 (16.3)	1.5 (19.5)
MINIMUM FAN PERFORMANCE	STATIC PRESSURE in•wg (Pa)	29 (730)	47 (1180)	6.7 (1680)	8.8 (2200)	*
	AIRFLOW cfm (L/s)	1100 (520)	1650 (780)	2200 (1030)	2750 (1290)	3300 (1580)

\* Above 10 in•wg (2500 Pa)

**OPERATOR SAFETY**

No safety hazards were apparent when normal precautions were observed.

**OPERATOR'S MANUAL**

No operator's manual was provided. It is recommended that the manufacturer provide natural air drying guidelines with each system.

**MECHANICAL HISTORY**

An extended durability test was not performed. No mechanical problems were encountered during testing. The bin and air distribution system is intended for grain drying and storage only.

SPECIFICATIONS	
<b>Make:</b>	Westeel
<b>Model:</b>	14 ft (43 m) diameter Welded Boot cw Natural Air Drying System
<b>Air Distribution System:</b>	perforated screen
- air transfer to grain	91 holes in <sup>2</sup> (14.1 holes/cm <sup>2</sup> )
- porosity	0.059 in (1.5 mm) diameter
- hole size	38.5 ft <sup>2</sup> (3.58 m <sup>2</sup> )
- air/grain interface/area	17.6 in (450 mm)
- fan mount diameter	

APPENDIX I	
MACHINE RATINGS	
The following rating scale is used in PAMI Evaluation Reports:	
Excellent	Fair
Very Good	Poor
Good	Unsatisfactory

# SUMMARY CHART

BADER HOODED	
<b>RETAIL PRICE</b>	\$875.00 (October 1988, f.o.b Humboldt, Sask.)
<b>RATE OF WORK</b>	
Drying Time	Average-Dry: 0.70 times Reference bin
	Through-Dry: 1.20 times Reference bin
<b>QUALITY OF WORK</b>	
Airflow	1.15 cfm/bu (15.0 L/s•m <sup>3</sup> ) with typical 3 hp (22 kW) centrifugal fan
Drying Uniformity	Top layer takes 32% longer than if uniformity ideal
<b>EASE OF OPERATION</b>	
Installation	Air distribution system could be field installed in Bader bins; Fan - <b>Fair</b>
Monitoring	<b>Fair</b> for average-dry; <b>Good</b> for through-dry
Cleaning	<b>Very Good</b> ; did not affect bin unloading
<b>FAN REQUIREMENTS</b>	Must deliver 1940 cfm (910 L/s) @ 3.7 in•wg (930 Pa) to achieve 1 cfm/bu (13 L/s•m <sup>3</sup> )
<b>OPERATOR SAFETY</b>	No safety hazards apparent
<b>OPERATOR'S MANUAL</b>	None provided
<b>MECHANICAL HISTORY</b>	No mechanical problems; could be epoxy coated for storing fertilizer

GREHI	
<b>RETAIL PRICE</b>	\$738.00 (October 1988, f.o.b Humboldt, Sask.)
<b>RATE OF WORK</b>	
Drying Time	Average-Dry: 1.10 times Reference bin
	Through-Dry: 1.20 times Reference bin
<b>QUALITY OF WORK</b>	
Airflow	0.80 cfm/bu (10.4 L/s•m <sup>3</sup> ) with typical 3 hp (2.2 kW) centrifugal fan
Drying Uniformity	Top layer takes 6% longer than if uniformity ideal
<b>EASE OF OPERATION</b>	
<b>Installation</b>	Air distribution system - could be field installed in any bin
	Fan/Transition unit <b>Fair</b> ; had to be removed to unload bin
<b>Monitoring</b>	<b>Fair</b> for average-dry; <b>Good</b> for through dry
<b>Cleaning</b>	<b>Poor</b> ; some grain remained in bin after augering complete; drying system restricts bin access
<b>FAN REQUIREMENTS</b>	Must deliver 1860 cfm (870 L/s) @ 82 in•wg (2050 Pa) to achieve 1 cfm/bu (13 L/s•m <sup>3</sup> )
<b>OPERATOR SAFETY</b>	Opening slide gate was potential safety hazard: screw tips protruded out bottom of bin
<b>OPERATOR'S MANUAL</b>	None provided
<b>MECHANICAL HISTORY</b>	No mechanical problems; could not be removed for storing fertilizer

Summary Chart Continued On Page 16

# SUMMARY CHART

Continued From Page 15

HARVEST HOPPER	
<b>RETAIL PRICE</b>	\$600.00 (October 1988 10b Humboldt, Sask)
<b>RATE OF WORK</b>	
Drying Time	Average-Dry: 1.00 times Reference bin Through-Dry: 1.30 times Reference bin
<b>QUALITY OF WORK</b>	
Airflow	0.85 cfm/bu (11.1 L/s•m <sup>3</sup> ) with typical 3 hp (2.2 kW) centrifugal fan
Drying Uniformity	Top layer takes 35% longer than if uniformity ideal
<b>EASE OF OPERATION</b>	
Installation	Air distribution system - factory installed Fan - <b>Very Good</b>
Monitoring	<b>Fair</b> for average-dry; <b>Good</b> for through dry
Cleaning	<b>Very Good</b> ; did not affect bin unloading
<b>FAN REQUIREMENTS</b>	Must deliver 1960 cfm (920 L/s) @ 75 in•wg (1880 Pa) to achieve 1 cfm/bu (13L/s•m <sup>3</sup> )
<b>OPERATOR SAFETY</b>	No safety hazards apparent
<b>OPERATOR'S MANUAL</b>	None provided
<b>MECHANICAL HISTORY</b>	No mechanical problems; epoxy coated for storing fertilizer

UNIVISION IN-LINE	
<b>RETAIL PRICE</b>	\$440 00 (October, 1988 f.o.b. Humboldt, Sask )
<b>RATE OF WORK</b>	
Drying Time	Average Dry: 0.90 times Reference bin Through Dry: 0.90 times Reference bin
<b>QUALITY OF WORK</b>	
Airflow	1.10 cfm/bu (14.3 L/s•m <sup>3</sup> ) with typical 3 hp (2.2 kW) centrifugal fan
Drying Uniformity	Top layer takes 17% longer than if uniformity ideal
<b>EASE OF OPERATION</b>	
Installation	Air distribution system - screen could be field installed in any bin with supports and air inlet Fan - <b>Fair</b>
Monitoring	<b>Fair</b> for average dry; <b>Good</b> for through-dry
Cleaning	<b>Very Good</b> ; did not affect bin unloading; some grain remained on top of duct after emptying
<b>FAN REQUIREMENTS</b>	Must deliver 1940 cfm (910 L/s) @ 45 inwg (1130 Pa) to achieve 1 cfm/bu (13 L/s•m <sup>3</sup> )
<b>OPERATOR SAFETY</b>	No safety hazards apparent
<b>OPERATOR'S MANUAL</b>	None provided
<b>MECHANICAL HISTORY</b>	No mechanical problems; could be easily removed for storing fertilizer

TRAIL RITE V AERATION	
<b>RETAIL PRICE</b>	\$748.00 (October 1988, fob. Humboldt, Sask )
<b>RATE OF WORK</b>	
Drying Time	Average-Dry: 1.20 times Reference bin Through-Dry: 1.10 times Reference bin
<b>QUALITY OF WORK</b>	
Airflow	1.00 cfm/bu (130 L/s•m <sup>3</sup> ) with typical 3 hp (2.2 kW) centrifugal fan
Drying Uniformity	Top layer takes 16% longer than if uniformity ideal
<b>EASE OF OPERATION</b>	
Installation	Air distribution system could be field installed in some bins Fan - <b>Good</b>
Monitoring	<b>Fair</b> for average-dry; <b>Good</b> for through-dry
Cleaning	<b>Very Good</b> ; did not affect bin unloading
<b>FAN REQUIREMENTS</b>	Must deliver 1840 cfm (860 L/s) @ 5.7 in.wg (1430 Pa) to achieve 1 cfm/bu (13 L/s•m <sup>3</sup> )
<b>OPERATOR SAFETY</b>	No safety hazards apparent
<b>OPERATOR'S MANUAL</b>	None provided
<b>MECHANICAL HISTORY</b>	No mechanical problems; epoxy coated for storing fertilizer

UNIVISION ULTRA-DRY	
<b>RETAIL PRICE</b>	\$1200.00 (October, 1988 fob Humboldt, Sask )
<b>RATE OF WORK</b>	
Drying Time	Average-Dry: 0.70 times Reference bin Through-Dry: 0.90 times Reference bin
<b>QUALITY OF WORK</b>	
Airflow	1.15 cfm/bu (15.0 L/s•m <sup>3</sup> ) with typical 3 hp (2.2 kW) centrifugal fan
Drying Uniformity	Outside layer takes 33% longer than if uniformity ideal
<b>EASE OF OPERATION</b>	
Installation	Air distribution system - factory installed in Univision bins Fan - <b>Good</b>
Monitoring	<b>Fair</b> for average dry; <b>Good</b> for through-dry
Cleaning	<b>Good</b> ; some grain remained in bin at high initial moisture contents
<b>FAN REQUIREMENTS</b>	Must deliver 1940 cfm (910 L/s) @ 3.8 in•wg (950 Pa) to achieve 1 cfm/bu (13 L/s•m <sup>3</sup> )
<b>OPERATOR SAFETY</b>	No safety hazards apparent
<b>OPERATOR'S MANUAL</b>	None provided
<b>MECHANICAL HISTORY</b>	No mechanical problems; could be epoxy coated for storing fertilizer

WESTEEL BOOT	
<b>RETAIL PRICE</b>	\$230.00 (October, 1988, f o b Humboldt, Sask)
<b>RATE OF WORK</b>	
Drying Time	Average-Dry: 1.00 times Reference bin Through-Dry: 1.20 times Reference bin
<b>QUALITY OF WORK</b>	
Airflow	0.85 cfm/bu (11.1 L/s•m <sup>3</sup> ) with typical 3 hp (2.2 kW) centrifugal fan
Drying Uniformity	Top layer takes 26% longer than if uniformity ideal
<b>EASE OF OPERATION</b>	
Installation	Air distribution system - could be either installed by dealer or in the field Fan - <b>Very Good</b>
Monitoring	<b>Fair</b> for average-dry; <b>Good</b> for through dry
Cleaning	<b>Very Good</b> ; did not affect bin unloading
<b>FAN REQUIREMENTS</b>	Must deliver 2200 cfm (1030 L/s) @ 6.7 in.wg (1680 Pa) to achieve 1 cfm/bu (13 L/s•m <sup>3</sup> )
<b>OPERATOR SAFETY</b>	No safety hazards apparent
<b>OPERATOR'S MANUAL</b>	None provided
<b>MECHANICAL HISTORY</b>	No mechanical problems



**ALBERTA FARM MACHINERY RESEARCH CENTRE**

3000 College Drive South  
Lethbridge, Alberta, Canada T1K 1L6  
Telephone: (403) 329-1212  
Fax: (403) 328-5562  
<http://www.agric.gov.ab.ca/navigation/engineering/afmrc/index.html>

**Prairie Agricultural Machinery Institute**

Head Office: P.O. Box 1900, Humboldt, Saskatchewan, Canada S0K 2A0  
Telephone: (306) 682-2555

Test Stations:

P.O. Box 1060 Portage la Prairie, Manitoba, Canada R1N 3C5 Telephone: (204) 239-5445 Fax: (204) 239-7124	P.O. Box 1150 Humboldt, Saskatchewan, Canada S0K 2A0 Telephone: (306) 682-5033 Fax: (306) 682-5080
---	---