

# Evaluation Report 176



## Spierco M80 Fertilizer Attachment

A Co-operative Program Between



# SPIERCO M80 FERTILIZER ATTACHMENT

## MANUFACTURER & DISTRIBUTOR:

Spierco Industries Ltd.  
5316 - 36 Street S.E.  
Calgary, Alberta  
T2C 2H2

## RETAIL PRICE:

\$1,440.00 (July, 1980, f.o.b. Lethbridge, to fit a 4.3 m (14 ft) Morris 80-14 Seed Rite grain drill with 200 mm (8 in) spacing)

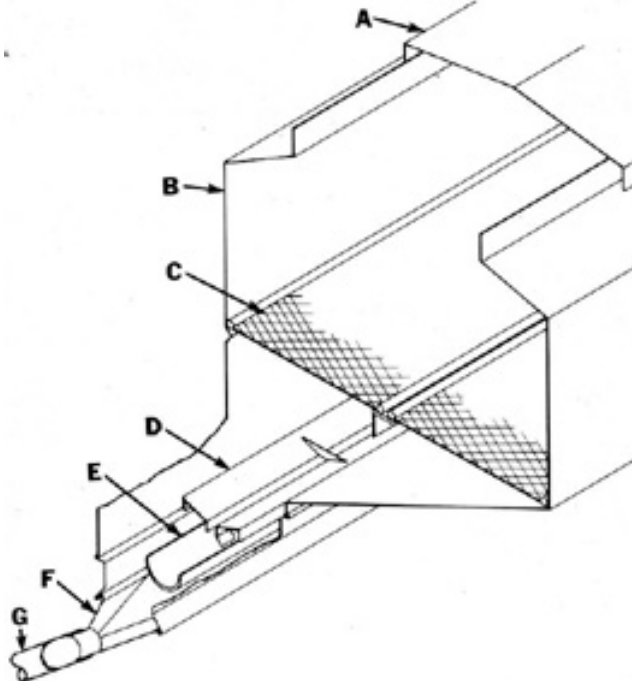

FIGURE 1. Spierco M80: (A) Lid, (B) Box, (C) Diamond Mesh Screen, (D) Baffle, (E) Oscillator, (F) Spout, (G) Delivery Tube.

## SUMMARY AND CONCLUSIONS

Overall functional performance of the Spierco M80 fertilizer attachment was very good. Performance was reduced by variation in application rates with changes in forward speed and by non-uniformity of distribution across the seeding width at low fertilizing rates.

Application rate was not affected by field roughness or level in the fertilizer box, and was only slightly affected by field slope. Application across the seeding width was uniform at high fertilizing rates but was non-uniform at low rates. Application uniformity was affected by side slope.

Actual application rates were slightly lower than indicated by the manufacturer's calibration. The calibration of the two boxes was slightly different. A large range of fertilizing rates was available with an adequate number of settings.

The fertilizer box was easy to clean, since the screens and baffles were easily removed. The box was well sealed. The operator's manual contained comprehensive instructions on operation and maintenance.

Only one minor mechanical problem with a drive cable occurred during the test.

## RECOMMENDATIONS

It is recommended that the manufacturer consider:

1. Supplying a metric calibration chart to aid in metric conversion.  
Chief Engineer: E. O. Nyborg  
Senior Engineer: E. H. Wiens

Project Engineer: K. Vil. Drever

## THE MANUFACTURER STATES THAT

With regard to recommendation number:

1. A metric calibration chart is now available.

NOTE: This report has been prepared using SI units of measurement. A conversion table is given in APPENDIX III.

## GENERAL DESCRIPTION

The Spierco M80 fertilizer attachment is designed to fit different makes and models of grain drills. The test attachment was equipped with mounts and drives designed for a Morris 80-14 Seed Rite grain drill<sup>1</sup>. It consisted of two boxes, one with nine delivery spouts and one with 12 delivery spouts, with 200 mm (8 in) spout spacing. Total box volume was about 0.46 m<sup>3</sup> (16.3 ft<sup>3</sup>), with a fully loaded fertilizer capacity of about 110 kg/m (70 lb/ft) of width.

An oscillating trough in the box bottom meters fertilizer through plastic discharge tubes to the grain box seed cups. Application rate is set by adjusting trough oscillation stroke.

FIGURE 1 shows a schematic view of the Spierco M80 while detailed specifications are given in APPENDIX I.

## SCOPE OF TEST

The Spierco M80 was mounted on a Morris 80-14 Seed Rite grain drill and was operated for 95 hours while applying fertilizer to about 268 ha (660 ac). It was evaluated for quality of work, ease of operation, ease of adjustment, operator safety and suitability of the operator's manual.

## RESULTS AND DISCUSSION

### QUALITY OF WORK

*Metering Accuracy:* The fertilizer metering system was calibrated in the laboratory with 11-48-0 fertilizer using a standard procedure<sup>2</sup>. Results were compared with the manufacturer's calibration (FIGURE 2). The left box applied slightly more fertilizer than the right box and application rates were usually from 5 to 15 kg/ha (4 to 14 lb/ac) less than indicated by the manufacturer. This is well within acceptable limits. Similar variation may be expected with different brands and types of fertilizer since flow rate depends on fertilizer type, granule size, density and moisture content.

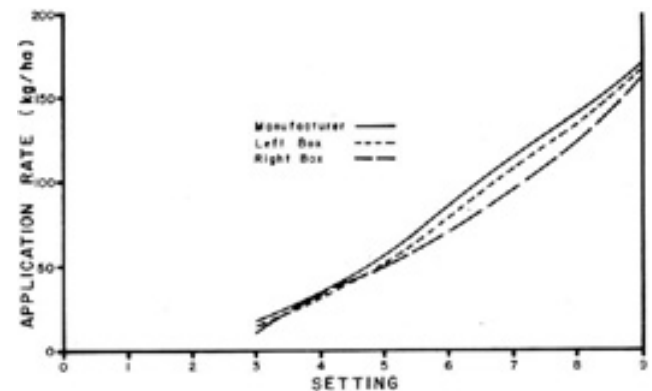

FIGURE 2. Calibration Curves for 11-48-0 Fertilizer.

The application rate was not affected by the level of fertilizer in the box or field roughness. It was, however, affected by ground speed and by field slope. Increasing the forward speed from 5 to 12 km/h (3 to 7 mph) caused a 19% decrease in application rate. Operating at a 10° side slope or travelling up or down a 150 slope caused the application rate to increase about 7%.

The coefficient of variation (CV)<sup>3</sup> is commonly used to describe the variation in application rates from individual spouts. It is accepted, for fertilizer application, that the CV should not be greater than 15%. If the CV is less than 15%, fertilizer application is uniform. If the CV is greater than 15%, the variation among individual spouts is excessive.

FIGURE 3 shows that the application uniformity depended on the application rate. Uniformity was good at higher application rates but was just within acceptable limits at common fertilizing rates. For example, when applying 11-48-0 fertilizer at 60 kg/ha (53 lb/ac) the CV was 10% for the right box and 14% for the left box. When

<sup>1</sup> See PAMI Evaluation Report E1979B

<sup>2</sup> PAMI T773, "Detailed Test Procedure for Grain Drills"

<sup>3</sup> The coefficient of variation is the standard deviation of application rates from individual fertilizer spouts expressed as a per cent of the mean application rate.

applying 40 kg/ha (36 lb/ac) the CV's increased to 11 and 17% for the right and left boxes respectively; Side slope caused uniformity to deteriorate. When applying 60 kg/ha (53 lb/ac) at a 10° side slope, the CV increased to 30%.

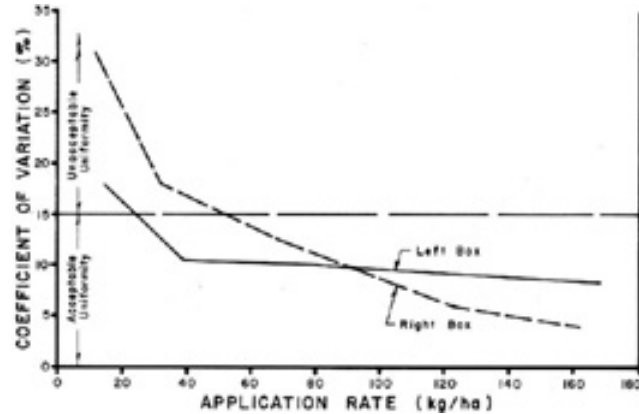

FIGURE 3. Uniformity of Fertilizer Distribution from Individual Spouts.

**EASE OF OPERATION**

**Filling:** The Spierco M80 was safe and convenient to fill when mounted on a Morris 80-14 Seed Rite grain drill. The lids opened to a 226 mm (9 in) width.

**Cleaning:** The Spierco M80 was easy to clean. The screens and baffles above the oscillator were easily removed. The oscillator could be inverted for complete cleaning and for storage.

**Moisture:** The fertilizer boxes were well sealed. No moisture entrance occurred during the test. If the attachment is left out in rain, it should be checked before operation to ensure that the oscillator is free and that the fertilizer has not caked.

**EASE OF ADJUSTMENT**

**Fertilizing Rate:** The fertilizer application rate was set by adjusting the stroke of the trough oscillation crank. The stroke setting was indicated by a pointer on the drive crank (FIGURE 4). A calibration chart, relating stroke setting to application rate (FIGURE 5) was provided for nine different brands of fertilizer commonly used on the prairies.

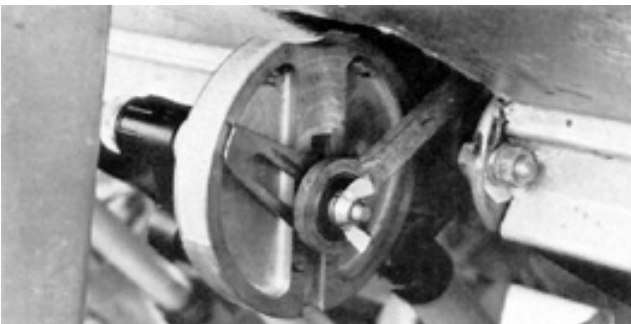

FIGURE 4. Rate Adjustment.

CALIBRATION CHART No. 5									
FERTILIZER RATES IN POUNDS PER ACRE									
Pointer Setting	11-48-0	11-55-0	16-20-0	27-14-0	34-0-0	46-0-0	18-36-10	21-0-0	23-23-0
1									
2									
3	15	20	15	15	10	15	20	25	15
4	30	30	30	25	20	30	35	50	30
5	50	45	50	40	35	35	50	70	45
6	75	65	70	60	55	50	70	100	65
7	100	85	95	80	75	65	100	135	95
8	125	110	120	105	100	90	125	170	110
9	150	140	145	130	120	105	150	195	140
10	185	170	180	165	150	130	190	250	180
11	235	210	220	210	185	160	230	305	225
12	270	250	260	230	210	200	260	340	250

FIGURE 5. Calibration Chart.

**Lubrication:** The manufacturer recommended periodic oiling of the flexible drive cables.

**OPERATOR SAFETY**

The Spierco M80 was safe to operate providing normal safety procedures were followed.

**OPERATOR'S MANUAL**

The operator's manual included useful information on mounting, operation and maintenance. A well illustrated, detailed parts list was included in the operator's manual while the calibration chart was provided as a decal on the box. The calibration chart did not include the density of the fertilizers used in preparation of the chart nor was a metric calibration chart supplied. It is recommended that the manufacturer consider supplying a metric calibration chart to aid in metric conversion.

**DURABILITY RESULTS**

TABLE 1 outlines the mechanical history of the Spierco M80 fertilizer attachment during 95 hours while fertilizing about 268 ha (660 ac). The intent of the test was evaluation of functional performance. The following problems occurred during functional testing. An extended durability evaluation was not conducted.

TABLE 1. Mechanical History

ITEM	HOURS	FIELD AREA (ha)
Drive		
- The fertilizer drive failed to disengage due to an improper placement of the washer at	5	14
The washer was replaced and no further problems were encountered.		
- The left fertilizer drive cable end loosened from the cable. The end was re-crimped onto the cable at	50,60,70	141,169,197

**APPENDIX I**

**SPECIFICATIONS**

<b>MAKE:</b>	Spierco Fertilizer Attachment
<b>MODEL:</b>	M80
<b>SERIAL NO.:</b>	Left Box: 151 Right Box: 176
<b>DIMENSIONS:</b>	
- effective application width	
- left box	2440 mm
- right box	1830 mm
- spacing of discharge tubes	203 mm
- number of discharge tubes	
- left box	12
- right box	9
<b>METERING SYSTEM:</b>	
- type	oscillating trough
- drive	gear and flexible cable from grain feed drive shaft (Morris Rod Weeder Part No. S 3023)
- adjustment	trough oscillation
- transfer to openers	plastic discharge tubes feeding into grain box seed cup
<b>FERTILIZER BOX CAPACITY:</b>	
- left box	0.26 m <sup>3</sup>
- right box	0.20 m <sup>3</sup>
<b>NUMBER OF LUBRICATION POINTS:</b>	occasional oiling of flexible drive

**APPENDIX II**

**MACHINE RATINGS**

The following rating scale is used in PAMI Evaluation Reports:

(a) excellent	(d) fair
(b) very good	(e) poor
(c) good	(f) unsatisfactory

**APPENDIX III**

**CONVERSION TABLE**

1 hectare (ha)	= 2.5 acres (ac)
1 kilometre/hour (km/h)	= 0.6 miles/hr (mph)
1 metre (m)	= 3.3 feet (ft)
1 millimetre (mm)	= 0.04 inches (in)
1 kilogram (kg)	= 2.2 pounds mass (lb)
1 cubic metre (m <sup>3</sup> )	= 35 cubic ft (ft <sup>3</sup> )
1 kilogram/hectare (kg/ha)	= 0.9 pounds/acre (lb/ac)
1 kilogram/metre (kg/m)	= 0.7 pounds/foot (lb/ft)
1 kilogram/cubic metre (kg/m <sup>3</sup> )	= 0.06 pounds/cubic foot (lb/ft <sup>3</sup> )



**ALBERTA  
FARM  
MACHINERY  
RESEARCH  
CENTRE**

3000 College Drive South  
Lethbridge, Alberta, Canada T1K 1L6  
Telephone: (403) 329-1212  
FAX: (403) 329-5562  
[http://www.agric.gov.ab.ca/navigation/engineering/  
afmrc/index.html](http://www.agric.gov.ab.ca/navigation/engineering/afmrc/index.html)

**Prairie Agricultural Machinery Institute**

Head Office: P.O. Box 1900, Humboldt, Saskatchewan, Canada S0K 2A0  
Telephone: (306) 682-2555

Test Stations:  
P.O. Box 1060  
Portage la Prairie, Manitoba, Canada R1N 3C5  
Telephone: (204) 239-5445  
Fax: (204) 239-7124

P.O. Box 1150  
Humboldt, Saskatchewan, Canada S0K 2A0  
Telephone: (306) 682-5033  
Fax: (306) 682-5080