

Evaluation Report 177

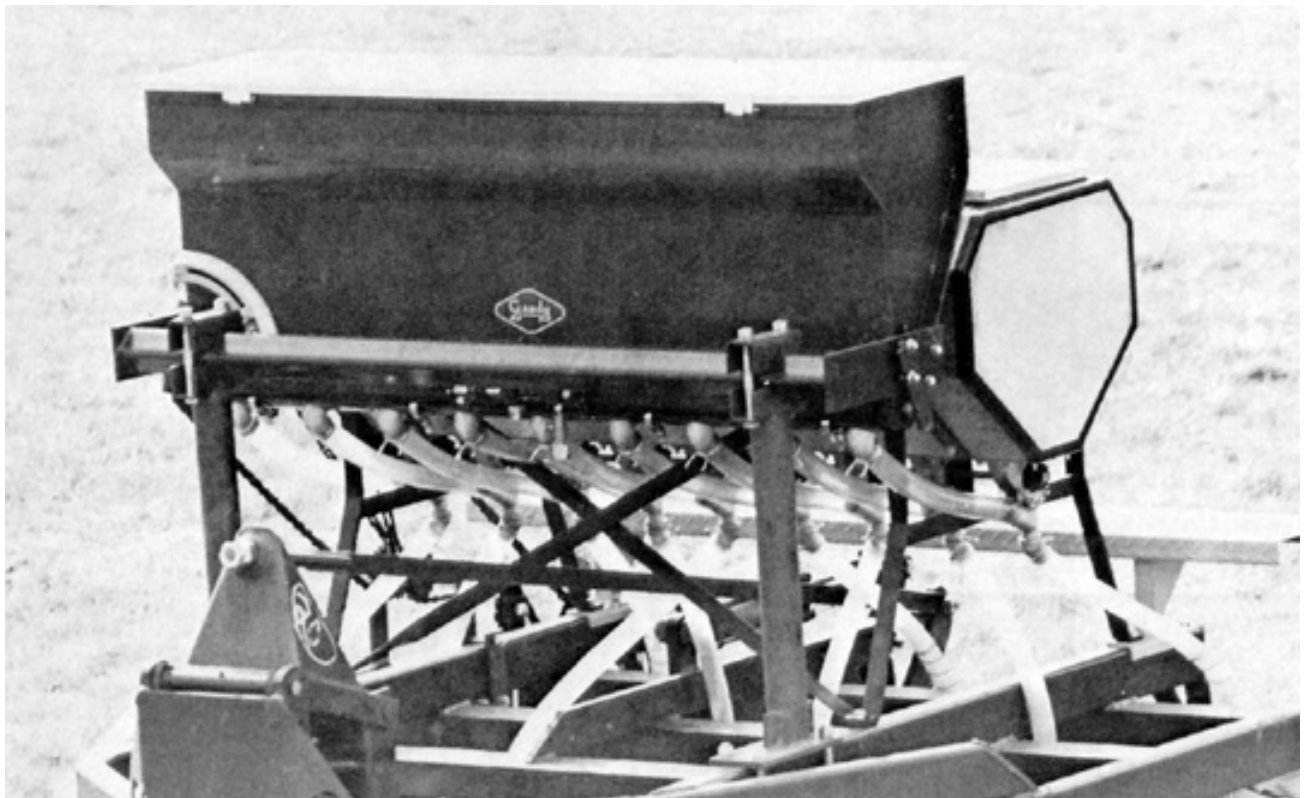

Gandy 44-NDK 59 Fertilizer Attachment

A Co-operative Program Between



GANDY 44-NDK 59 FERTILIZER ATTACHMENT

MANUFACTURER:

Gandy Company Manufacturers
526 Gandrud Road
Owatonna, Minnesota 55060
U.S.A.

DISTRIBUTOR:

Noble Cultivators Ltd.
P.O. Box 60
Nobleford, Alberta
T0L 1S0

RETAIL PRICE:

\$1,006.88 (July, 1980, f.o.b. Lethbridge, to fit a 2.1 m (6.8 ft)
Noble DK5 grain drill with 230 mm (9 in) spacing.)

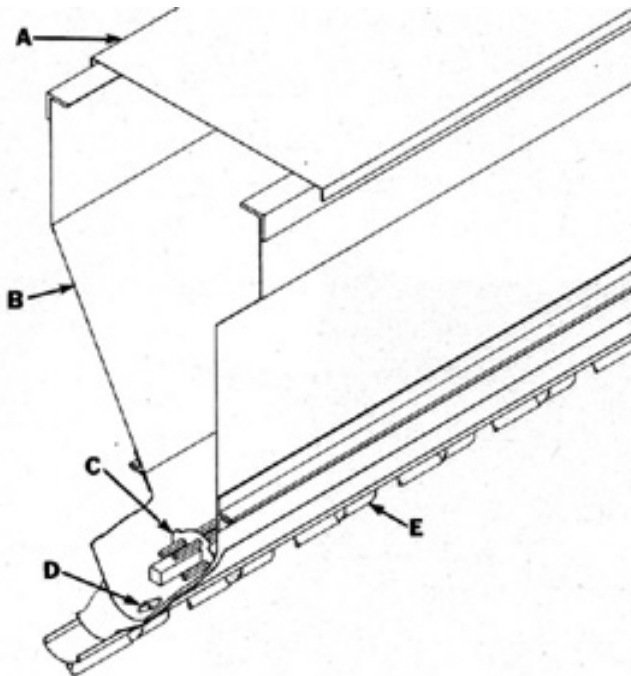

FIGURE 1. Gandy 44-NDK 59: (A) Lid, (B) Box, (C) Rotor Bar, (D) Orifice, (E) Spout.

SUMMARY AND CONCLUSIONS

Overall functional performance of the Gandy 44-NDK 59 fertilizer attachment was *very good*. Performance was reduced by variation in application rates with changes in forward speed and by plugging of the delivery tubes when travelling down slopes greater than 10°.

Application rate was not affected by field roughness or level in the fertilizer box, and was only slightly affected by field slope unless delivery tubes plugged. Application across the seeding width was very uniform.

The manufacturer's calibration was accurate and a large range of fertilizing rates was available with an adequate number of settings.

The fertilizer box was easy to clean since the rotor bar and box bottom were easily removed. The box was well sealed. The operator's manual contained comprehensive instructions on operation and maintenance.

No mechanical problems occurred during the test.

RECOMMENDATIONS

It is recommended that the manufacturer consider:

1. Supplying a metric calibration chart to aid in metric conversion.

Chief Engineer: E. O. Nyborg

Senior Engineer: E. H. Wiens

Project Engineer: K. W. Drever

THE MANUFACTURER STATES THAT

With regard to recommendation number:

1. If it is Canadian government policy to state calibration in metric terms, we will comply. For the benefit of our customers, we will also continue to state calibration in Imperial units.

NOTE: This report has been prepared using SI units of measurement. A conversion table is given in APPENDIX III.

GENERAL DESCRIPTION

The Gandy 44-NDK 59 fertilizer attachment is designed to fit different makes and models of grain drills. The test attachment was equipped with mounts and drives designed for a Noble DK5 grain drill.¹ It consisted of a 0.18 m³ (6.3 ft³) box, with nine delivery spouts at 230 mm (9 in) spacing, with a fully loaded fertilizer capacity of about 90 kg/m (60 lb/ft) of width.

Fertilizer is metered through adjustable orifices in the box bottom into plastic discharge tubes to the grain drill seed cups. A rotor bar, located above the orifices is driven from the grain drill jack shaft to ensure agitation. Application rate is set by adjusting the orifice opening size or forward speed. The orifices automatically close when the drill is lifted out of the ground.

FIGURE 1 shows a schematic view of the Gandy 44-NDK 59 fertilizer attachment while detailed specifications are given in APPENDIX I.

SCOPE OF TEST

The Gandy 44-NDK 59 was mounted on a Noble DK5 grain drill and was operated for 62 hours while applying fertilizer to about 90 ha (220 ac). It was evaluated for quality of work, ease of operation, ease of adjustment, operator safety and suitability of the operator's manual.

RESULTS AND DISCUSSION

QUALITY OF WORK

Metering Accuracy: The fertilizer metering system was calibrated in the laboratory with 11-48-0 fertilizer using a standard procedure². Results were compared with the manufacturer's calibration tables. The manufacturer's calibration for 11-48-0 fertilizer was accurate. Some variation may be expected with different brands and types of fertilizer since flow rates depend upon fertilizer type, granule size, density and moisture content.

The application rate was not significantly affected by the level of fertilizer in the box or by field roughness. Travelling up a slope did not affect the application rate but travelling down slopes greater than 10° caused the discharge hoses to plug due to insufficient hose slope. A 10° side slope caused about a 5% increase in application.

Forward speed affected application rate since the flow rate through the orifices was constant over a range of speeds. As a result, for each orifice setting, higher application rates occurred at low speeds and lower application rates at high speeds. Constant ground speed was necessary for uniform application.

The coefficient of variation (CV)³ is commonly used to describe the variation in application rate from individual spouts. It is accepted, for fertilizer application, that the CV should not be greater than 15%. If the CV is less than 15%, fertilizer application is uniform. If the CV is greater than 15%, the variation among individual spouts is excessive. Application from the Gandy fertilizer attachment was very uniform with the CV ranging from 3 to 8% over the full range of application rates.

EASE OF OPERATION

Filling: The Gandy 44-NDK 59 was safe and convenient to fill when mounted on a Noble DK5 grain drill. The lid opened to a 350 mm (14 in) width.

1 See PAMI Evaluation Report E1979C.

2 PAMI T773, "Detailed Test Procedure for Grain Drills."

3 The coefficient of variation is the standard deviation of application rates from individual fertilizer spouts expressed as a per cent of the mean application rate.

Cleaning: Cleaning was convenient. The rotor bar was easily removed and the bottom of the box could be removed for a thorough cleaning.

Moisture: The fertilizer box was well sealed. No moisture entrance occurred during the test. If the attachment is left out in the rain it should be checked before operation to ensure that the fertilizer has not caked.

EASE OF ADJUSTMENT

Fertilizing Rate: The fertilizer application rate was set by adjusting the orifice opening with the rate gauge located on the front of the box (FIGURE 2). Care had to be taken to ensure that the grain drill was lifted out of the ground when adjusting the rate gauge. Attempting to adjust the rate gauge with the grain drill in the ground caused the shut-off cylinder to force the rate gauge orifices fully open, resulting in fertilizer spillage and the possibility of pinched fingers. The wing nuts locking the rate gauge in position had to be tightened with pliers to prevent the shut-off cylinder from forcing the gauge open.



FIGURE 2. Rate Gauge.

Constant and precise forward speed was needed to maintain accurate application rates. A calibration chart (FIGURE 3) was provided for five different brands of fertilizer commonly used on the prairies.

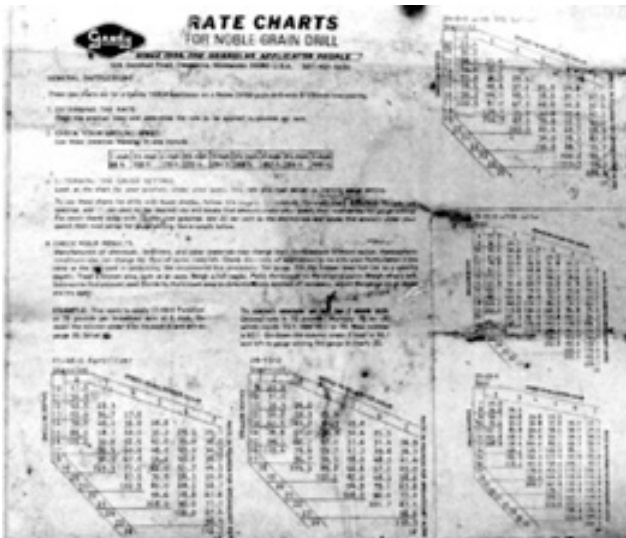

FIGURE 3. Calibration Chart.

Lubrication: The manufacturer recommended lubricating the rotor bearings twice a day. Access to the pressure grease fittings was convenient.

OPERATOR SAFETY

The Gandy 44-NDK 59 was safe to operate providing normal safety procedures were followed.

OPERATOR'S MANUAL

The operator's manual included useful information on mounting, operation and maintenance. A calibration chart was provided as a decal on the box. The calibration chart did not include the density of the fertilizers used in preparation of the chart nor was a metric calibration chart supplied. It is recommended that the manufacturer consider supplying a metric calibration chart to aid in metric conversion.

DURABILITY RESULTS

The intent of the test was evaluation of functional performance. An extended durability evaluation was not conducted. No mechanical problems occurred during 62 hours of operation.

APPENDIX I	
SPECIFICATIONS	
MAKE:	Gandy Fertilizer Attachment
MODEL:	44-NDK 59
SERIAL NO.:	113416
DIMENSIONS:	
- effective application width	2057 mm
- spacing of discharge tubes	173 mm
- number of discharge tubes	9
METERING SYSTEM:	
- type	variable orifice
- drive (rotor)	chain from grain drill jack shaft
- adjustment	gauge controlling orifice size; forward speed
- transfer to openers	plastic discharge tubes feeding into grain box drop tubes
FERTILIZER BOX CAPACITY:	0.18 m ³
NUMBER OF CHAIN DRIVES:	1
NUMBER OF LUBRICATION POINTS:	2

APPENDIX II	
MACHINE RATINGS	
The following rating scale is used in PAMI Evaluation Reports:	
(a) excellent	(d) fair
(b) very good	(e) poor
(c) good	(f) unsatisfactory

APPENDIX III	
CONVERSION TABLE	
1 hectare (ha)	= 2.5 acres (ac)
1 kilometre/hour (km/h)	= 0.6 miles/hour (mph)
1 metre (m)	= 3.3 feet (ft)
1 millimetre (mm)	= 0.04 inches (in)
1 kilogram (kg)	= 2.2 pounds mass (lb)
1 cubic metre (m ³)	= 35 cubic feet (ft ³)
1 kilogram/hectare (kg/ha)	= 0.9 pounds/acre (lb/ac)
1 kilogram/metre (kg/m)	= 0.7 pounds/foot (lb/ft)
1 kilogram/cubic metre (kg/m ³)	= 0.06 pounds/cubic foot (lb/ft ³)



**ALBERTA
FARM
MACHINERY
RESEARCH
CENTRE**

3000 College Drive South
Lethbridge, Alberta, Canada T1K 1L6
Telephone: (403) 329-1212
FAX: (403) 329-5562
<http://www.agric.gov.ab.ca/navigation/engineering/afmrc/index.html>

Prairie Agricultural Machinery Institute

Head Office: P.O. Box 1900, Humboldt, Saskatchewan, Canada S0K 2A0
Telephone: (306) 682-2555

Test Stations:
P.O. Box 1060
Portage la Prairie, Manitoba, Canada R1N 3C5
Telephone: (204) 239-5445
Fax: (204) 239-7124

P.O. Box 1150
Humboldt, Saskatchewan, Canada S0K 2A0
Telephone: (306) 682-5033
Fax: (306) 682-5080