

Evaluation Report 95

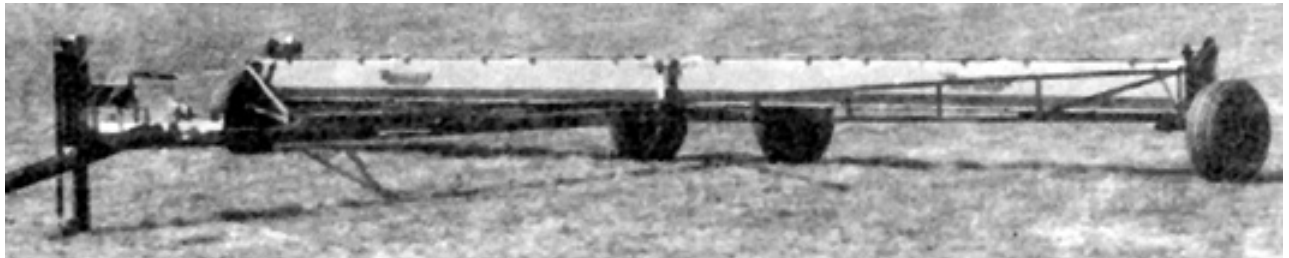

Barber 11 m (36 ft) Granular Applicator

A Co-operative Program Between



BARBER 11 m (36 ft) GRANULAR APPLICATOR

MANUFACTURER:
Barber Engineering Company
N. 1404 Regal Street
Spokane, Washington 99202
U.S.A.

DISTRIBUTOR:
J. D. Fraser Equipment Ltd.
731 - 10th Avenue, S.W.
Calgary, Alberta
T2R 0B3

RETAIL PRICE:
\$6,425.00 (March, 1978, f.o.b. Calgary), with micro feed screw
and acre counter.

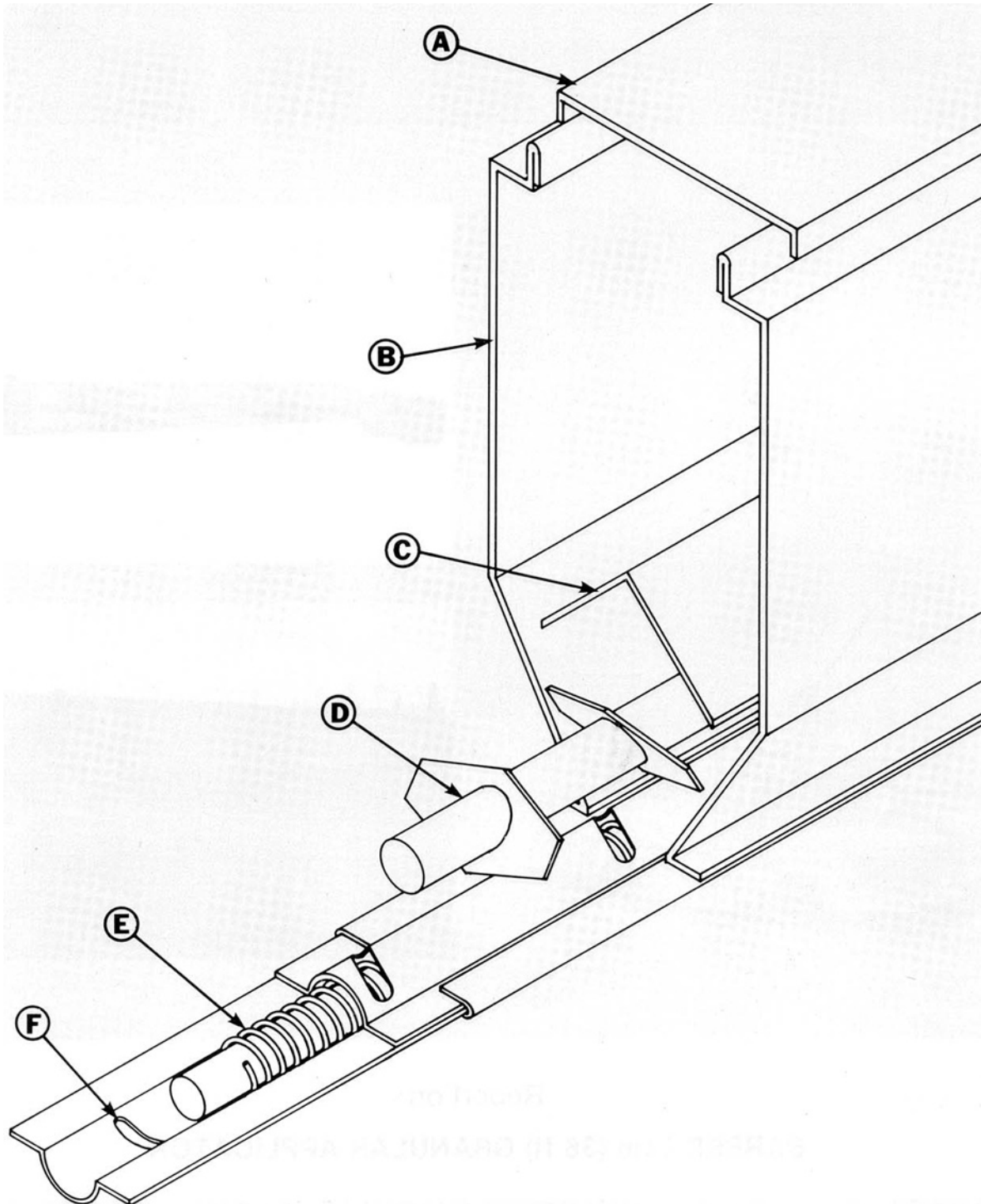

FIGURE 1. Schematic View of Barber Granular Applicator: (A) Hopper Lid, (B) Hopper, (C) Agitator Shield, (D) Agitator, (E) Feed Screw, (F) Discharge Opening.

SUMMARY AND CONCLUSIONS

Overall functional performance of the Barber 11 m (36 ft) granular applicator was *fair* when used for distributing granular Avadex BW and granular Treflan. Metering uniformity was *very good* but distribution of granules on the soil surface was *poor*. The distribution on the ground was non-uniform in the direction of travel and banding of granules occurred across the width of spread. Its performance as a fertilizer distributor was not evaluated. Durability of the Barber, during functional testing, was *excellent*.

The Barber had a sufficient range of adjustment to suit recommended application rates for both granular Avadex BW and granular Treflan. The manufacturer's calibration chart was in error, indicating about 4 kg/ha (3.5 lb/ac) high at normal Avadex BW application rates on smooth fields. Application rates were affected by field roughness and were consistently 1.5 kg/ha (1.3 lb/ac) higher on rough fields than on smooth fields, for the same feed screw setting. Application rates were not affected by ground speed or level of granules in the hopper but were slightly affected by field slope.

Although the metering of granules from the hopper discharge openings was very uniform across the spreading width, resulting in a coefficient of variation of only 6%, the granules fell on the soil in bands below each opening, resulting in a coefficient of variation of 160%. The output at each discharge opening also surged as the screw flite passed the opening, resulting in varying delivery from each opening, in the direction of travel. Thorough soil incorporation was necessary to get uniform distribution in the soil, due to both the banding and the variation of application in the direction of travel.

The Barber applicator performed well on rough and hilly fields. Maximum field capacity was about 18 ha/h (44 ac/h). The hopper held about 455 kg (1000 lb) of Avadex BW which was sufficient to cover about 30 ha (75 ac), at common application rates, without filling. Hopper lids were weathertight. Hoppers were of suitable height for easy filling from the ground. The agitator and feed screw pulverized Avadex BW granules, resulting in incomplete emptying of the hoppers. Feed screw assemblies were easily removed for cleaning. The application rate was easy to adjust.

A calibration pan, which was provided with the applicator, aided in field calibration checks in calm weather, but in windy conditions, granules blew out of the pan. The acre counter which was used in checking calibration, was about 10% in error.

The applicator was convenient to operate and was fairly easy to fold into transport or field position, taking one man about 10 minutes. The end wheels left tracks in the field to aid lining up successive field passes. Granules falling from each discharge opening were visible from the tractor. Drives for the two applicator halves could be separately disengaged from the tractor seat. They could only be engaged from the ground.

The hitch jack was inconvenient to reach in transport position. The jack lowering screw could also be inadvertently screwed out too far, causing the check valve to fall out. Transport maneuverability was good but transport position hitch weight was too large for safe towing behind a small truck.

No mechanical problems occurred during the test.

RECOMMENDATIONS

It is recommended that the manufacturer consider:

1. Using deflectors to reduce the banding of granules below the discharge openings.
2. Investigating the possibility of reducing surging of granules from discharge openings.
3. Improving calibration chart accuracy for Avadex BW.

4. Preparing the operating instructions in both English and SI units to facilitate applicator operation after conversion to the SI system.
5. Improving acre counter accuracy.
6. Supplying a slow moving vehicle sign.

Chief Engineer - E. O. Nyborg

Senior Engineer - E. H. Wiens

Project Engineer - K. W. Drever

THE MANUFACTURER STATES THAT

With regard to recommendation number:

1. Deflectors or scatter boards are available as an option at additional cost.
2. This recommendation will be taken under consideration.
3. A new improved calibration chart for Avadex BW is being published.
4. Operating instructions in both English and SI units will be supplied as SI units become more prominent in all areas.
5. Links that trip the acre counter can be added or removed to adjust the acre counter to any tire pressure.
6. Slow moving vehicle signs are available as an option at additional cost.

GENERAL DESCRIPTION

The Barber 11 m (36 ft) granular applicator is a trailer mounted, dribble type spreader. It consists of two hoppers, with total capacity of 0.65 m³ (23 ft³), supported on four wheels. Granules are metered from the hopper bottoms by ground driven feed screws through 72 openings spaced at 150 mm (6 in), resulting in an 11 m (36 ft) spreading width. Granules fall directly to the ground from each hopper opening. A rotary agitator is located above each feed screw.

Application rate is controlled by changing sprockets on the feed screw drive. An acre meter and catch pan are provided to assist in calibration. The test machine was equipped with an optional microfeed screw to permit the applicator to be used with granular herbicides. The standard feed screw, which permits the applicator to be used as a fertilizer distributor, was not evaluated.

Each side of the applicator folds ahead for transporting.

FIGURE 1 shows a schematic view of the Barber applicator while detailed specifications are given in APPENDIX I.

SCOPE OF TEST

The Barber applicator was operated for 75 hours while applying granular Avadex BW on about 960 ha (2370 ac). Field speeds ranged from 10 to 16 km/h (6 to 10 mph). The applicator was evaluated for quality of work, ease of operation, operator safety and suitability of the operator's manual. Metering and distribution system accuracy was evaluated in the laboratory with Avadex BW. Standard procedures¹ were used to determine the effect of field and machine variables on metering and distribution.

RESULTS AND DISCUSSION

QUALITY OF WORK

Calibration Chart Accuracy: FIGURE 2 compares the manufacturer's calibration for Avadex BW with calibration results

¹PAMI T772-R78, Detailed Test Procedures for Granular Applicators.

obtained in simulated smooth and rough fields. The manufacturer's calibration chart was in error over the normal range of application rates used for Avadex BW. For example, at a 0.6 drive sprocket ratio (6 and 10 tooth sprocket combination), the manufacturer's indicated application rate was 13.5 kg/ha (12.0 lb/ac) while the actual application rate was only 11 kg/ha (9.8 lb/ac) on rough fields and 9.5 kg/ha (8.5 lb/ac) on smooth fields. Application rates were consistently 1.5 kg/ha (1.3 lb/ac) higher on rough fields than on smooth fields over the normal range of application rates.

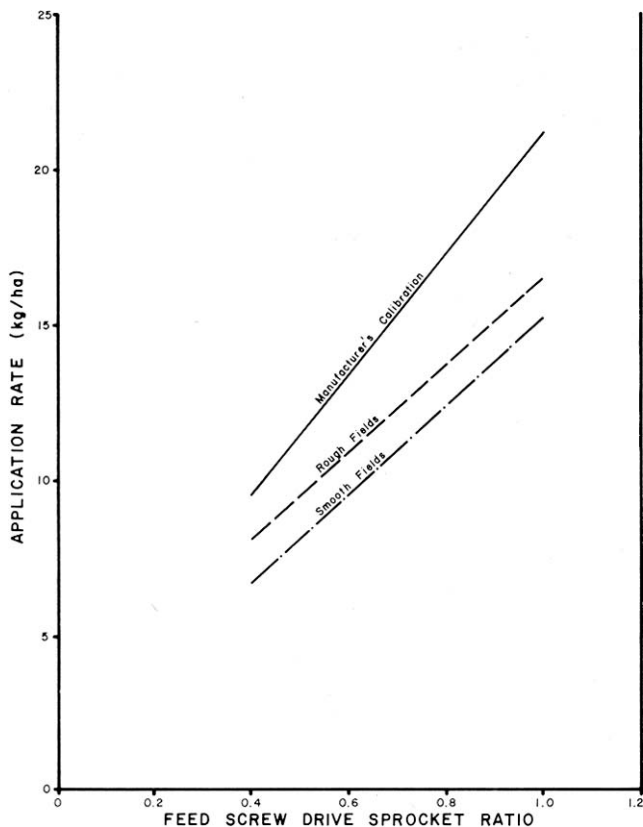

FIGURE 2. Calibration Curves for Avadex BW.

The application rate was not significantly affected by the level of Avadex BW in the hopper or by ground speed. Application rate was, however, affected by both fore-and-aft and sideways field slope. FIGURE 3 shows the effect of field slope on application rate. Operating the applicator on a 5% side slope decreased application by about 0.6 kg/ha (0.5 lb/ac) if the outer end of the applicator was low and increased application by about 0.6 kg/ha (0.5 lb/ac) if the outer end was high. Application decreased by about 1 kg/ha (1 lb/ac) when distributing up or down a 10% slope.

Metering Accuracy: FIGURE 4 shows typical delivery rates from sixteen adjacent discharge openings while applying 13.7 kg/ha (12.2 lb/ac) of Avadex BW at 9 km/h (5.6 mph). Application rates from the individual discharge openings varied from 12.7 to 15.6 kg/ha (11.3 to 13.9 lb/ac), resulting in a Coefficient of Variation² of only 6%. The variability in delivery rates from individual discharge openings remained constant over the normal range of application rates.

Spreading Accuracy: Although metering from the hoppers was very uniform, distribution on the ground was not uniform. Granules metered from the hoppers fell directly on the ground in bands,

²The coefficient of variation (CV) is the standard deviation of the application rates, expressed as a percent of the mean application rate. A low CV represents uniform application whereas a high CV indicates non-uniform application. One granular herbicide manufacturer has suggested that the CV should be no greater than 10%.

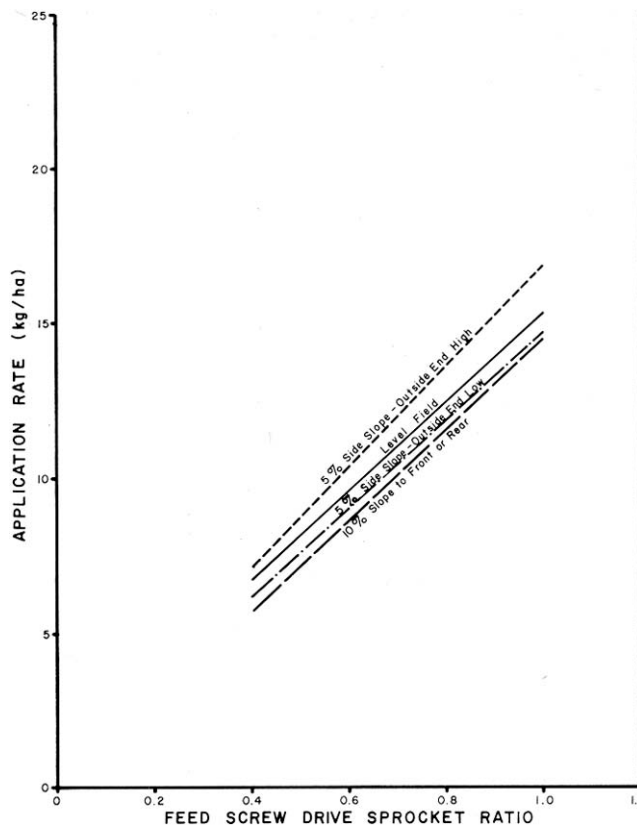

FIGURE 3. Effect of Field Slope on Application Rate of Avadex BW.

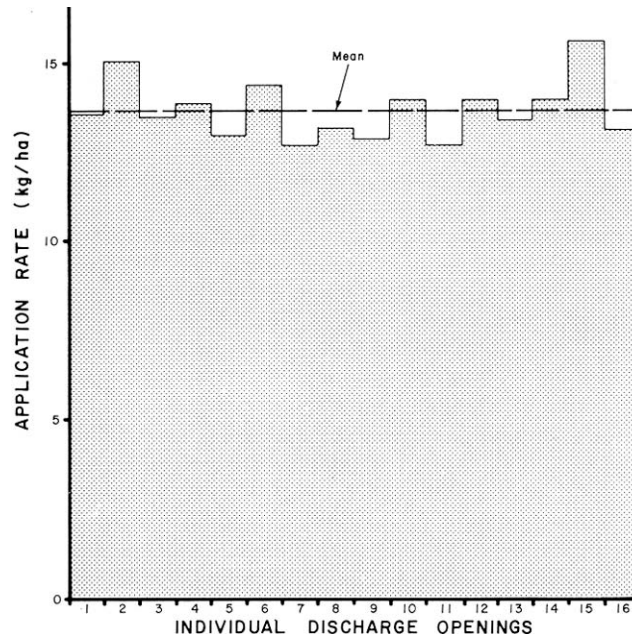

FIGURE 4. Typical Variation in Delivery Rates from Adjacent Discharge Openings.

below each discharge opening. FIGURE 5 shows a typical distribution of Avadex BW granules on the ground under a 1.14 m (45 in) wide section of the applicator when applying 17 kg/ha (15 lb/ac). Granules were deposited in adjacent 75 mm (3 in) wide bands below each discharge opening, with an uncovered 75 mm (3 in) wide strip between each band, resulting in a coefficient of variation of 160%. Similar distribution patterns occurred at all application rates. Although this distribution pattern varied with wind

and field roughness, the high concentration below each discharge opening indicated that thorough soil incorporation was necessary to get uniform distribution in the soil. Suitable deflector plates could possibly improve distribution on the soil surface.

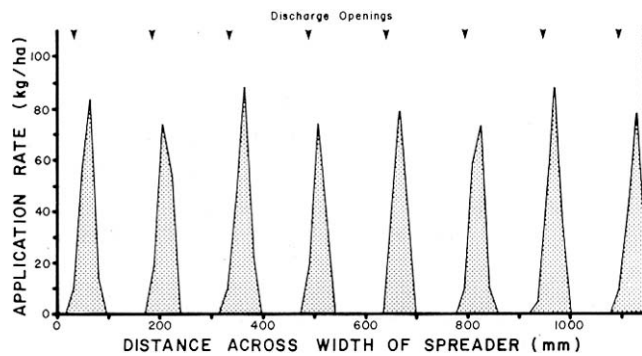

FIGURE 5. Typical Distribution of Avadex BW Granules on the Ground under a 1.14 m (45 in) Wide Section of the Applicator when Applying 17 kg/ha (15 lb/ac).

Distribution of granules also varied in the direction of travel. Delivery from each discharge opening surged each time a screw flite passed an opening. FIGURE 6 shows a typical distribution of Avadex BW granules in the direction of travel below one discharge opening when the distributor was set to deliver 17 kg/ha (15 lb/ac). Application rates in the direction of travel, varied from 11 to 23 kg/ha (9.8 to 20.5 lb/ac). Surges occurred every 1.5 to 3.5 m (5 to 11 ft) of forward travel, depending on the application rate. Surges from adjacent discharge openings did not occur at the same time, so high and low application did not occur simultaneously across the full width of the applicator.

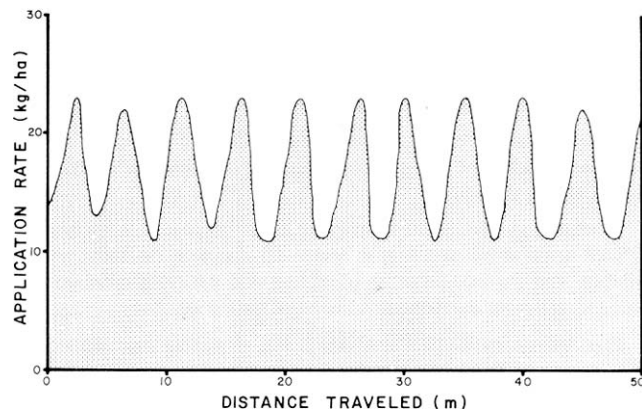

FIGURE 6. Typical Distribution of Avadex BW Granules Below One Discharge Opening in the Direction of Travel.

Granule Pulverization: The agitator and feed screw pulverized 10 to 20% of Avadex BW granules as they were distributed. Pulverization did not affect calibration and probably had no adverse effect on weed control. Finely pulverized granules, however, would not readily flow out of the hopper, meaning that the hopper could not be completely emptied in the field (FIGURE 7). About 36 kg (80 lb) of Avadex BW remained in the hopper.

Acre Meter: The Barber applicator was equipped with an acre meter. The actual field area covered was about 10% greater than indicated by the meter. A metric land area meter was not available.

Calibration with Granular Treflan: The Barber applicator was not evaluated with granular Treflan. There was sufficient feed screw drive speed adjustment to achieve the 28 kg/ha (25 lb/ac) application rate recommended for granular Treflan. Since the filler

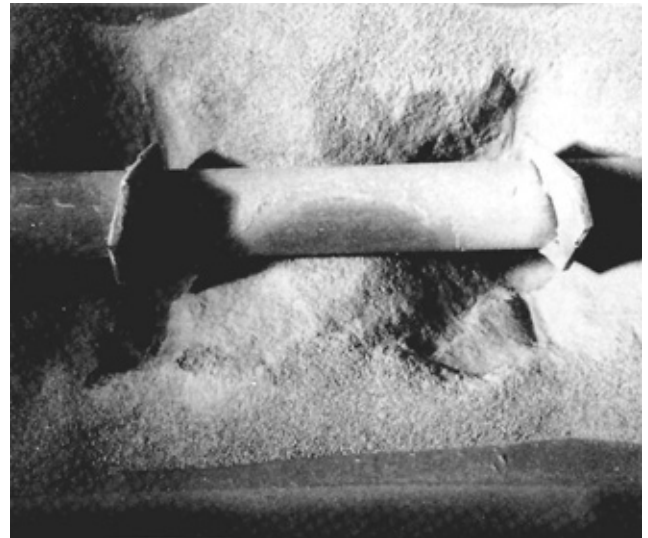

FIGURE 7. Pulverized Avadex BW Granules Remaining in the Hopper.

material used in Treflan granules is similar to the filler material used in Avadex BW it is expected that performance of both would be similar. Due to different granule densities, calibration curves would be different.

EASE OF OPERATION

Hitching: The Barber applicator could easily be hitched to a tractor or truck. A hydraulic jack was provided for raising or lowering the hitch tongue. The jack was somewhat awkward to use as it was necessary to reach over the front of the applicator (FIGURE 8). Occasionally, the jack valve was unscrewed too far and the check valve fell out, causing oil to leak.



FIGURE 8. Hitch Jack Location.

Hoppers: The hoppers were conveniently positioned for filling with bagged granules while standing on the ground. The hopper lids, however, were only 140 mm (5.5 in) wide, so care had to be exercised to prevent spilling. The hopper lids did not extend the full length of the hopper so granules had to be pushed into the hopper ends by hand.

The hoppers held about 455 kg (1000 lb) of Avadex BW which was sufficient to cover about 30 ha (75 ac) before refilling, when

applying 13.5 kg/ha (12.0 lb/ac). Since the hoppers did not completely empty in the field (FIGURE 7) they had to be cleaned by hand when finishing spreading. The hopper bottoms and feed screws were easily removed to permit thorough cleaning at the end of a season (FIGURE 9). The hopper lids were weathertight. No leakage of rain into the hoppers occurred during the test.

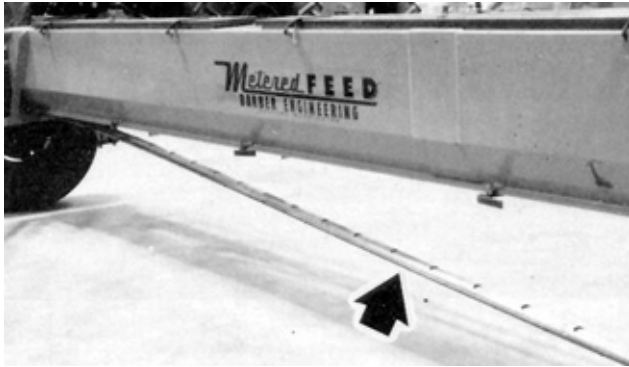

FIGURE 9. Feed Screw Housing Removal for Hopper Cleaning.

Setting the Application Rate: The application rate was conveniently adjusted by changing feed screw drive sprockets (FIGURE 10). A wrench was needed to loosen the idler sprocket to adjust chain tension. Chain links had to be removed to tighten the chain for some sprocket combinations. Since the feed screw was ground driven, changing the ground speed did not affect the application rate.

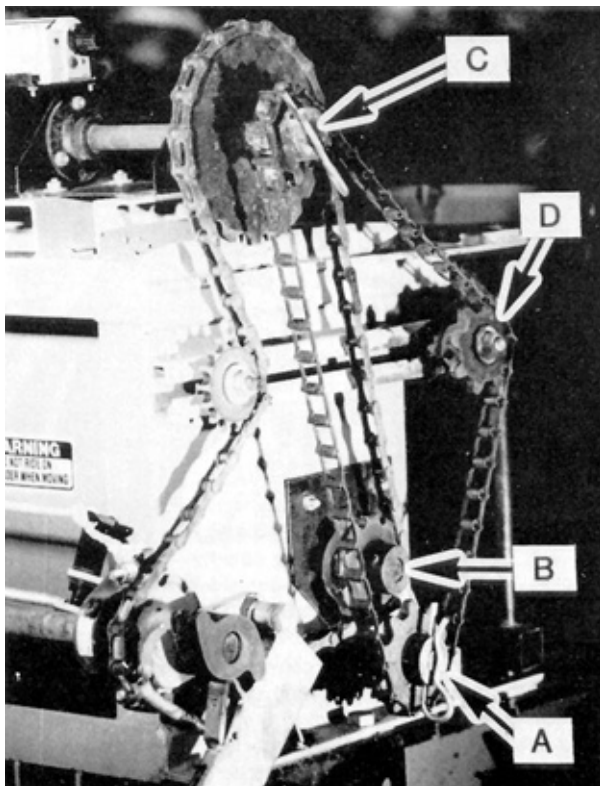

FIGURE 10. Feed Screw Drive: (A) Feed Screw Sprocket, (B) Agitator Sprocket, (C) Drive Sprocket, (D) Idler Sprocket.

A calibration pan (FIGURE 11) was provided to check field application rates. The calibration pan was easy to use but a scale was needed to weigh the collected material. The calibration pan could not be used on windy days as some of the granules blew out of the pan. The 10% error in the acre meter also had to be considered when checking field calibration.

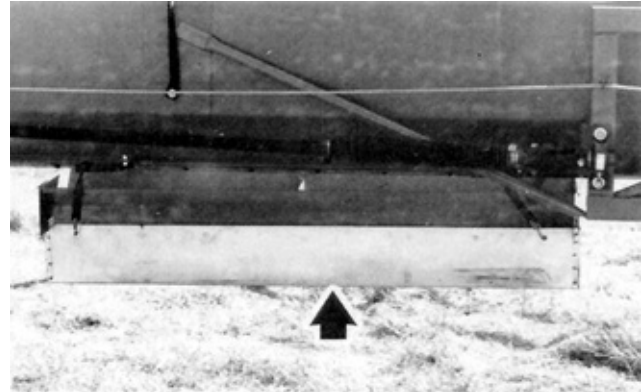

FIGURE 11. Field Calibration Pan.

Field Operation: The Barber applicator performed well on rough and hilly fields. Performance was satisfactory at speeds up to 16 km/h (10 mph) resulting in a maximum field capacity of about 18 ha/h (44 ac/h). Usually, the available tractor speed was the limiting factor in selecting a suitable field speed.

The applicator end wheels left tracks that were easy to follow when making successive passes down the field, especially on fields with little trash cover.

Each half of the applicator could be shut off when finishing a field by pulling ropes to disengage the feed screw drive. The drives could not be started from the tractor seat. To start distribution, each drive had to be engaged from the ground.

Granules falling from the feed screw openings could be seen from the tractor seat giving a convenient check that the applicator was operating properly.

Transporting: The Barber applicator could be placed in transport or field position by one man in about 10 minutes. No tools were needed. The tractor had to be unhitched and the hitch dropped to the ground before the side sections could be folded.

The Barber applicator transported well at normal road speeds. Backing and turning when in transport was convenient.

The unloaded hitch weight in transport position was about 635 kg (1395 lb). This was too heavy for safe towing behind a one-half ton truck. A larger truck or tractor was more suitable for transporting the applicator.

Lubrication: The Barber applicator had 14 grease fittings requiring daily lubrication and 10 requiring seasonal lubrication. All fittings were accessible.

OPERATOR SAFETY

The Barber applicator was safe to operate if normal safety procedures were followed.

A slow moving vehicle sign was not provided. It is recommended that a sign be supplied to comply with provincial safety regulations.

OPERATOR'S MANUAL

The operator's manual outlined calibration and storage procedures. A calibration chart was attached to the applicator. Since the calibration chart was significantly in error (FIGURE 2), it is recommended that a modified calibration chart be provided.

Operating instructions and calibration charts were prepared in English units. It is recommended that they also be prepared using SI (metric) units to facilitate applicator operation after conversion to the SI system.

MECHANICAL PROBLEMS

The Barber applicator was operated for 75 hours while spreading Avadex BW on about 960 ha (2370 ac). The intent of the test was evaluation of functional performance and an extended durability evaluation was not conducted. No mechanical problems occurred during functional testing.

APPENDIX I

SPECIFICATIONS

MAKE: Barber Granular Applicat(
MODEL: 11 m (36 ft)
SERIAL NUMBER: 36FG77465

OVERALL DIMENSIONS:	<u>Field Position</u>	<u>Transport Position</u>
- height	1590 mm (5.2 ft)	1590 mm (5.2 ft)
- length	8200 mm (26.9 ft)	8200 mm (26.9 ft)
- width	12100 mm (39.7 ft)	2100 mm (6.9 ft)

METERING SYSTEM:

type	feed screw with fixed discharge holes
drive	chain from end wheels
adjustment	feed screw speed
transfer to ground	free fall from discharge openings
number of discharge openings	72
discharge opening spacing	152 mm (6 in)
discharge height	540 mm (21 in)
effective spreading width	10,970 mm (36 ft)

WEIGHTS (with empty hoppers):

	<u>Field Position</u>	<u>Transport Position</u>
- left wheel	245 kg (540 lb)	0
- left inner wheel	280 kg (620 lb)	330 kg (725 lb)
- right inner wheel	280 kg (620 lb)	330 kg (725 lb)
- right wheel	245 kg (540 lb)	0
- hitch	<u>240 kg (525 lb)</u>	<u>635 kg (1395 lb)</u>
Total	1290 kg (2845 lb)	1295 kg (2845 lb)

WHEELS:

- number	4
- tire size	12.5 x 15.6 ply, rib implement

HOPPER CAPACITY: 0.65 m³ (23 ft³)

NUMBER OF LUBRICATION POINTS: 24

OPTIONAL EQUIPMENT:

- fertilizer feed screw
- foam marking kit
- deflectors
- slow moving vehicle sign

APPENDIX II

MACHINE RATINGS

The following rating scale is used in PAMI in Evaluation Reports:

(a) excellent	(d) fair
(b) very good	(e) poor
(c) good	(f) unsatisfactory

APPENDIX III

METRIC UNITS

In keeping with the Canadian metric conversion program, this report has been prepared in SI units. For comparative purposes, the following conversions may be used:

1 kilometre per hour (km/h)	= 0.62 mile per hour (mph)
1 hectare (ha)	= 2.47 acres (ac)
1 kilogram (kg)	= 2.20 pounds (lb)
1 kilogram per hectare (kg/ha)	= 0.89 pound per acre (lb/ac)
1 metre (m) = 1000 millimetres (mm)	= 39.37 inches (in)



**ALBERTA
 FARM
 MACHINERY
 RESEARCH
 CENTRE**

3000 College Drive South
 Lethbridge, Alberta, Canada T1K 1L6
 Telephone: (403) 329-1212
 FAX: (403) 329-5562
<http://www.agric.gov.ab.ca/navigation/engineering/afmrc/index.html>

Prairie Agricultural Machinery Institute

Head Office: P.O. Box 1900, Humboldt, Saskatchewan, Canada S0K 2A0
 Telephone: (306) 682-2555

Test Stations:

P.O. Box 1060

Portage la Prairie, Manitoba, Canada R1N 3C5

Telephone: (204) 239-5445

Fax: (204) 239-7124

P.O. Box 1150

Humboldt, Saskatchewan, Canada S0K 2A0

Telephone: (306) 682-5033

Fax: (306) 682-5080