

# Evaluation Report

# 360



## Greenbelt 10-4 Forage Deck

A Co-operative Program Between



ALBERTA  
FARM  
MACHINERY  
RESEARCH  
CENTRE



PRAIRIE AGRICULTURAL MACHINERY INSTITUTE

# GREENBELT 10-4 FORAGE DECK

## MANUFACTURER:

Greenbelt Systems  
3 Winfield Way  
Winnipeg, Manitoba  
R2R 1V8

**RETAIL PRICE:** \$13,150.00 (April 1984, f.o.b. Portage la Prairie, Manitoba), complete with Tilt Ramp, 2nd Beater and Wind Guard.

## DISTRIBUTORS:

Managro Harvestore Systems  
Box 128  
2319 McGillivray Blvd.  
Fort Whyte, Manitoba  
R0G 0R0

Western Harvestore Systems  
Bag 6373  
Spruce Grove, Alberta  
T0E 2C0

Prairie Harvestore Systems  
R.R. #4, Box 96  
Saskatoon, Saskatchewan  
S7K 3J7

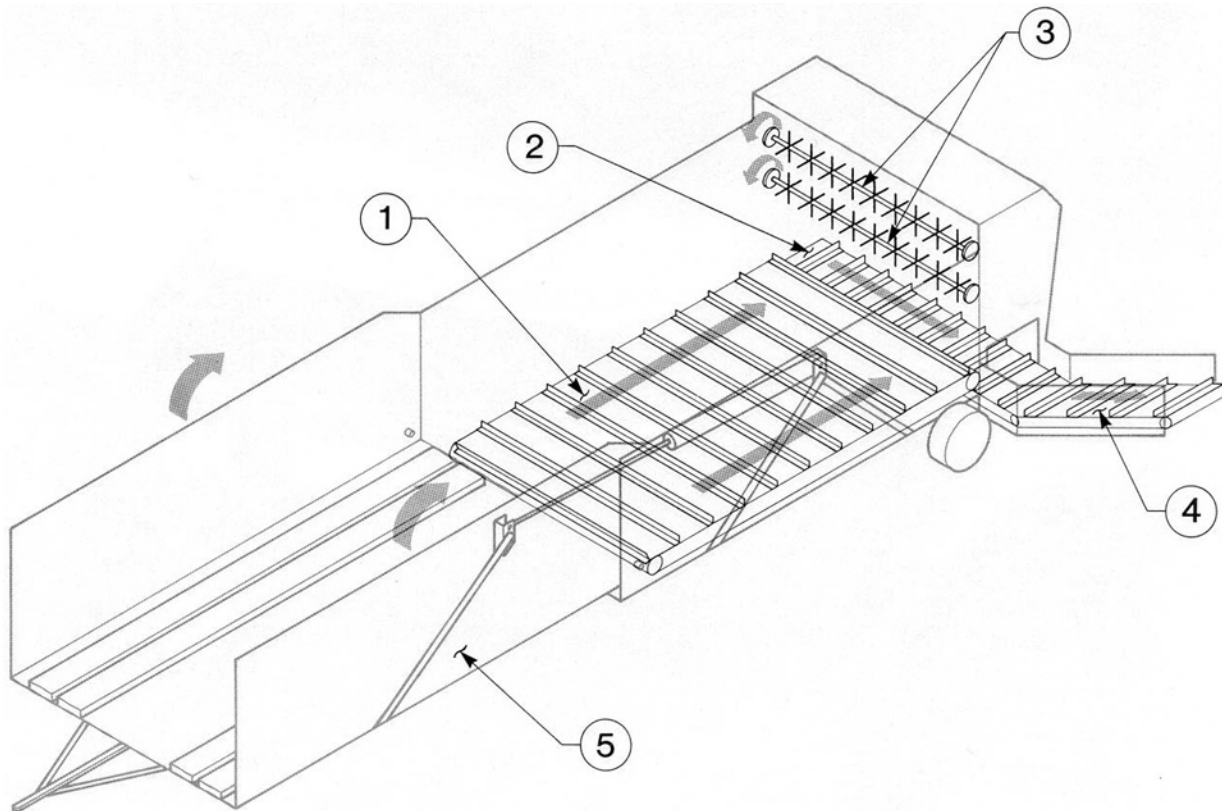

FIGURE 1. Greenbelt Forage Deck: (1) Main Deck Conveyor, (2) Cross Conveyor, (3) Beaters, (4) Cross Conveyor Extension, (5) Tilt Ramp.

## SUMMARY AND CONCLUSIONS

**Quality of Work:** Capacity of the forage deck was several times that of the forage blowers used during the tests. The conveyors and beaters were very aggressive in all crops. The forage deck was quickly cleaned using the high speed setting of the main deck conveyor.<sup>1</sup>

The Greenbelt 10-4 was easy to position at the silo. All controls were conveniently located and easy to use.

**Power Requirements:** The Greenbelt 10-4 was hydraulically driven and required a 12 gal (US)/min (46 L/min) flowrate at 1800 psi (12,000 kPa). Total power requirement was 12.8 hp (9.5 kW).

**Safety:** No safety problems were encountered during the evaluation.

**Operator Manual:** The operator manual was well written and illustrated.

**Durability:** No durability problems occurred during the test.

## RECOMMENDATIONS

It is recommended that the manufacturer consider:

1. Supplying an optional hydraulic cooler to allow the forage deck to be used with tractors without oil coolers.
2. Supplying a perforated pipe above the beaters to facilitate the addition of water to legume forage.
3. Installing a ladder or step to allow the operator to safely observe the main deck conveyor and beaters.

<sup>1</sup>See Machine Ratings APPENDIX II.

4. Modifications to the cross conveyor extension to alleviate spillage.

Senior Engineer: G.M. Omichinski

Project Engineer: C. W. Chapman

## THE MANUFACTURER STATES THAT

With regard to recommendation number:

1. Four years ago we offered a heat exchanger utilizing water that is normally directed into the blower. Since then, most tractors used have been equipped with oil coolers and we have had very limited requests. The heat exchanger is still available at modest cost.
2. We have seen this done and could supply on request.
3. The tire seemed to make a good, non-slip place to stand. Will take under advisement.
4. Special shields were designed a year ago and are planned for future production.

## GENERAL DESCRIPTION

The Greenbelt 10-4 is a hydraulically driven forage deck which is used to convey forage from dump trucks to forage blowers. Forage which is dumped from trucks into the deck is transferred to the main conveyor by a tilting ramp. Two beaters transfer the forage to a cross conveyor.

FIGURE 1 shows the location of the major components and detailed specifications are given in APPENDIX I.

## SCOPE OF TEST<sup>2</sup>

The Greenbelt 10-4 was operated for 50 hours while conveying alfalfa, clover and corn silage.

It was evaluated for rate of work, power requirements, ease of operation and adjustment, operator safety and suitability of the operator manual.

## RESULTS AND DISCUSSION

### RATE OF WORK

The capacity of the forage deck was limited by the conveying rate of the forage blower used for the tests. Capacity of the forage deck and blower system ranged from 27 to 40 ton/h (24 to 36 t/h). The forage deck itself was capable of a conveying rate several times these capacities. The maximum speed of the main deck conveyor was 16 ft/min (4.9 m/min) which quickly cleared any forage remaining in the deck.

### POWER REQUIREMENTS

The Greenbelt forage deck is hydraulically driven and required a flow of 12 gal (US)/min (46 L/min) at a pressure of 1800 psi (12,000 kPa). Maximum power requirement for the forage deck was 12.8 hp (9.5 kW). A tractor with a maximum power takeoff rating of 65 hp (49 kW) would have sufficient power to operate both the forage blower and the Greenbelt forage deck.

The tractor should have a minimum hydraulic reserve capacity of 1.5 gal (US) (5.7 L), to meet the requirements of the two double acting cylinders on the tilt ramp, and be equipped with a hydraulic oil cooler. It is recommended that the manufacturer supply an optional hydraulic oil cooler to allow the forage deck to be used with tractors without oil coolers.

### EASE OF OPERATION AND ADJUSTMENT

**Positioning:** The Greenbelt could be easily positioned using a tractor. Proper alignment of the cross conveyor with the blower hopper was necessary to avoid spillage. Two adjustable jacks aided in leveling the forage deck. The wheels, tilt ramp and main deck should be blocked up to reduce movement, keep the deck level, and reduce the load on the hitch jacks.

**Controls:** The operation of the Greenbelt was controlled with three hydraulic flow control valves. One valve controlled the speed of the beaters and cross conveyor. The second valve controlled the speed of the main deck conveyor, which varied the feedrate of the forage. A hydraulic spool valve operated the tilt ramp.

All controls were convenient and easy to use.

**Tilt Ramp:** The tilt ramp operated smoothly and evenly throughout the test and was capable of hoisting an 8 ton (7.2 t) load of forage. Minimum operator vigilance was necessary when backing a truck into the 10.25 ft (3.1 m) wide tilt ramp. The manufacturer recommended that the wheel stops be bolted onto the ramp to avoid the truck wheels or endgate from striking the main deck conveyor and that the tilt ramp spool valve be left in float position to eliminate any load on the hydraulic cylinders when backing loaded trucks on to the ramp.

**Beaters:** The Greenbelt 10-4 was equipped with two beaters which feed the forage to the cross conveyor. The beaters were aggressive in all crops. The beater speed could be adjusted to match crop conditions. Some gumming occurred on the beaters and rear wall of the Greenbelt when conveying legume forage. The addition of water above the beaters alleviated the problem. It is recommended that the manufacturer consider supplying a perforated pipe above the beaters to facilitate the addition of water to legume forage.

It was difficult for the operator to observe the main deck conveyor and beaters when standing beside the forage deck. It is recommended that the manufacturer install a ladder or step to allow the operator to safely observe the main deck conveyor and beaters.

**Cross Conveyor and Extension:** The variable speed cross conveyor effectively moved forage to the blower. Some spillage occurred at the joint between the conveyor and conveyor extension. It is recommended that the manufacturer consider modifications to alleviate spillage problems. The manufacturer recommended that the end of the extension not be raised more than 14 in (350 mm) from the level position.

**Adjustments:** Few adjustments were needed during the 50 hour test. The pressure at which the hydraulic relief valve opened was increased after the main deck conveyor stalled. The adjustment allowed the hydraulic output of the tractor to match the requirements of the forage deck.

Adjustment of the conveyor chains was easy.

**Lubrication:** The Greenbelt 10-4 had 9 pressure grease fittings, one drive chain and 6 conveyor chains which required weekly lubrication. One gear box required annual lubrication.

**Transporting:** The Greenbelt trailed well at speeds below 20 mph (32 km/h). Extreme caution had to be exercised when transporting due to a wide transport width of 15.6 ft (4.8 m) (FIGURE 2).

The manufacturer recommended that the deck be emptied of all material and that a suitable safety chain be attached. A pick-up truck, with minimum gross vehicle weight of 7500 lbs (3400 kg), was required to transport the Greenbelt due to a hitch weight of 1370 lbs (686 kg).



FIGURE 2. Transport Position.

## OPERATOR SAFETY

The Greenbelt 10-4 was safe to operate and service as long as common sense was used and the manufacturer's safety recommendations were followed.

<sup>2</sup>Prairie Agricultural Machinery Institute Detailed Test Procedure for Forage Decks.

## OPERATOR MANUAL

The operator manual was well written and contained information on assembly, operation and safety. A complete parts list was included.

## DURABILITY RESULTS

No mechanical problems occurred during the 50 hour test. The intent of the test was evaluation of the functional performance. An extended durability test was not conducted.

### APPENDIX

#### SPECIFICATIONS

**MAKE:** Greenbelt  
**MODEL:** 10-4  
**SERIAL NUMBER:** 11188

#### WEIGHTS:

-- left rear wheel	2354 lbs	(1070 kg)
-- right rear wheel	2046 lbs	(930 kg)
-- hitch point	1509 lbs	(686 kg)
-- total	5909 lbs	(2686 kg)

#### TRANSPORT POSITION DIMENSIONS:

-- maximum length	30.3 ft	(9.3 m)
-- maximum width		
with cross conveyor up	15.6 ft	(4.8 m)
-- maximum height	6.9 ft	(2.1 m)
-- ground clearance	6.3 in	(160 mm)
-- hitch height	19.7 in	(500 mm)

#### FIELD POSITION DIMENSIONS:

-- maximum length	30.3 ft	(9.3 m)
-- maximum width		
-- with cross conveyor down	16.6 ft	(5.1 m)
-- maximum height	6.9 ft	(2.1 m)

**TIRES:** two 9.5 L - 15.6 ply implement

**COMPONENT SPEEDS:** (at hydraulic flow of 17.1 gal (US)/min (65 L/min))

**Beaters**

-- upper	0 to 165 rpm	adjustable
-- lower	0 to 165 rpm	adjustable

**Conveyors**

-- cross conveyor	0 to 4.5 ft/sec	(0 to 1.38 m/sec)
-- main deck conveyor	0 to 0.25 ft/sec	(0 to 0.08 m/sec)

#### BEATER DIAMETER:

-- upper	15.6 in	(400 mm)
-- lower	18.7 in	(480 mm)

#### MAIN DECK CONVEYOR:

-- width	two, 4.8 ft	(1.5 m)
-- type	Pintle chain	

#### CROSS CONVEYOR:

-- width	18.7 in	(480 mm)
-- type	Pintle chain	

#### MAIN DECK DIMENSIONS:

-- height	3.4 ft	(1.1 m)
-- width	10.2 ft	(3.1 m)
-- length	15.6 ft	(4.8 m)

#### TILT RAMP DIMENSIONS:

-- height	3.4 ft	(1.1 m)
-- width	10.1 ft	(3.1 m)
-- length	11.9 ft	(3.7 m)

### APPENDIX III

#### CONVERSION TABLE

Acre (ac) x 0.405	Hectare (ha)
Foot (ft) x 0.305	Metre (m)
Inches (in) x 25.4	Millimetres (mm)
Horsepower (hp) x 0.746	Kilowatt (kW)
Miles/Hour (mph) x 1.61	Kilometre/Hour (km/h)
Pounds Force (lb) x 4.45	Newton (N)
Pounds Force/Foot (lb/ft) x 14.6	Newton/Metre (N/m)
Pounds Force-Feet (lb-ft) x 1.36	Newton-Metre (N-m)
Pounds Force/Square Inch (psi) x 6.89	Kilopascal (kPa)
Pounds Mass (lb) x 0.454	Kilogram (kg)
Tons Mass (ton) x 0.91	Tonnes (t)
Gallon (US) (gal (US)) x 3.8	Litre (L)
Gallon (US)/minute (gal (US)/min) x 3.8	Litre/Minute (L/min)

### APPENDIX II

#### MACHINE RATINGS

The following rating scale is used in Machinery Institute Evaluation Reports:

Excellent	Fair
Very Good	Poor
Good	Unsatisfactory

## SUMMARY CHART

# GREENBELT FORAGE DECK

RETAIL PRICE: \$13,150.00

(April 1984, f.o.b. Portage la Prairie, Man.)

	RATING	COMMENTS
<b>QUALITY OF WORK</b>		
Capacity	Very Good	-- limited by capacity of forage blower used in the tests.
Cleaning	Very Good	-- high speed setting cleaned deck quickly.
<b>EASE OF OPERATION AND ADJUSTMENT</b>		
Positioning	Very Good	-- easily moved with tractor.
Controls	Very Good	-- convenient to use.
Cross Conveyor	Good	-- some spillage between cross conveyor & cross conveyor extension,
<b>OPERATOR SAFETY</b>	Very Good	-- caution decals were provided.
<b>OPERATOR MANUAL</b>	Very Good	-- well written and illustrated.
<b>POWER REQUIREMENTS</b>	12.8 hp	-- hydraulically driven.

**CAUTION**

This summary chart is not intended to represent all of the final conclusions of the evaluation report. The relevance of the ratings is second ary to the information provided in the full text of the report. It is not recommended that a purchase decision be based only on the summary chart.



**ALBERTA  
FARM  
MACHINERY  
RESEARCH  
CENTRE**

3000 College Drive South  
Lethbridge, Alberta, Canada T1K 1L6  
Telephone: (403) 329-1212  
FAX: (403) 329-5562  
<http://www.agric.gov.ab.ca/navigation/engineering/afmrc/index.html>

### **Prairie Agricultural Machinery Institute**

Head Office: P.O. Box 1900, Humboldt, Saskatchewan, Canada S0K 2A0  
Telephone: (306) 682-2555

Test Stations:  
P.O. Box 1060  
Portage la Prairie, Manitoba, Canada R1N 3C5  
Telephone: (204) 239-5445  
Fax: (204) 239-7124

P.O. Box 1150  
Humboldt, Saskatchewan, Canada S0K 2A0  
Telephone: (306) 682-5033  
Fax: (306) 682-5080