

Evaluation Report 270



John Deere 665 Central Metering Seeder

A Co-operative Program Between



ALBERTA
FARM
MACHINERY
RESEARCH
CENTRE



PRAIRIE AGRICULTURAL MACHINERY INSTITUTE

JOHN DEERE 665 CENTRAL METERING SEEDER

MANUFACTURER:

John Deere Des Moines Works
Des Moines, Iowa 50306
U.S.A.

DISTRIBUTOR:

John Deere Ltd.
P.O. Box 1000
Grimsby, Ontario
L3M 4H5

RETAIL PRICE: \$56,791.95 (February, 1982, f.o.b. Lethbridge, Alberta). John Deere 665 central metering seeder complete with optional loading auger (without selector valve) and with optional cultivator mounted three-row harrows.

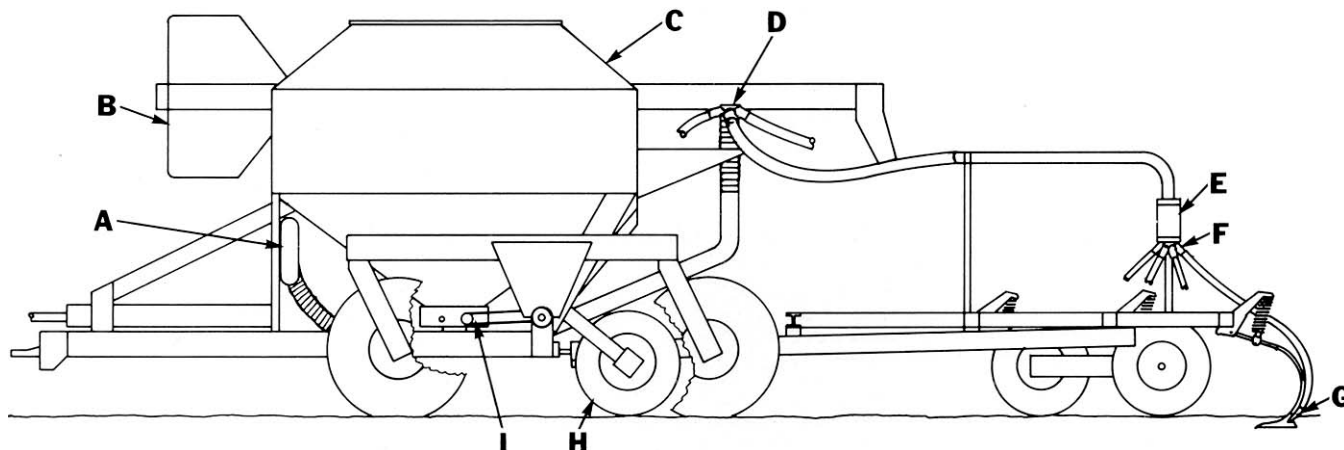

FIGURE 1. John Deere 665 Central Metering Seeder: (A) Fan, (B) Loading Auger, (C) Tanks, (D) Primary Header, (E) Electronic Monitoring System, (F) Secondary Header, (G) Seed Boot, (H) Meter Drive Wheel, (I) Metering System.

SUMMARY AND CONCLUSIONS

Overall functional performance of the John Deere 665 central metering seeder was *very good* in all seeding conditions. Performance was *very good* when banding fertilizer. The John Deere 665 was suitable for banding fertilizer at application rates up to 262 kg/ha (233 lb/ac) at 9 km/h (5.5 mph). Higher application rates were possible at reduced speeds.

Seed placement was good in most conditions. Variation in seed depth was slightly higher than with a conventional hoe drill when measured in the same fields under the same seeding conditions. Row spacing and seed band width behind each seed boot provided ample stubble for good windrow support. Maintaining accurate cultivator frame levelling and ensuring a seed depth of at least 50 mm (2 in) were critical in ensuring good emergence.

The manufacturer's metering system calibrations were accurate in wheat, barley, oats and fertilizer. The measured calibration for rapeseed was about 20% higher than the manufacturer's calibration at normal seeding rates.

Distribution uniformity across the machine width in wheat, barley, oats and rapeseed was acceptable at all normal seeding rates. Distribution uniformity was acceptable over the entire application rate range for fertilizer.

Field bounce, field slope and ground speed variation had little effect on metering rates. Field slope had a small effect on distribution uniformity.

Operator visibility of the cultivator mainframe was obstructed by the tanks.

Seeding rate was easily adjusted with a wrench. Tank and meter cleanout was convenient. Tank filling with the optional filler auger was convenient. Five fittings and five wheel bearings on the applicator required greasing.

The John Deere 665 Central Metering seeder could be placed in transport position in less than five minutes.

Rate of work usually ranged from 9.7 to 12.2 ha/h (24 to 30 ac/h). About 62 ha (153 ac) could be seeded before refilling both tanks when seeding wheat at a normal seeding rate.

Tractor size depended on soil conditions, seeding depth, ground speed, and soil finishing attachments. In light primary tillage, at a 75 mm (3 in) depth and 8 km/h (5 mph), a 132 kW (177 hp) tractor was needed to operate the seeder. In heavy primary tillage at the same depth and speed, a 155 kW (208 hp) tractor was needed.

The centre frame cultivator tires were overloaded in transport. Care was required to avoid operator injury while lowering the optional filler auger.

The operator's manual contained useful information on assembly, safety, specifications, adjustment, maintenance and operation.

Only minor mechanical problems occurred during evaluation.

RECOMMENDATIONS

It is recommended that the manufacturer consider:

1. Providing a suggested setting for the fan damper to reduce grain crackage when seeding rapeseed.
2. Supplying a calibration setting so the area meter can be used for readout in SI units.
3. Reducing overall transport height to avoid contact with overhead lines.
4. Improving tank divider partition construction to prevent leaking of material between tanks.

Senior Engineer: E. H. Wiens

Project Engineer: R. K. Allam

THE MANUFACTURER STATES THAT

With regard to recommendation number:

1. The operator's manual for 1983 machines will include a suggested setting for the fan damper which will allow rapeseed to be seeded with reduced crackage.
2. The operator's manual for 1982 machines contains a calibration setting for adjusting the area meter to read out in SI units.
3. There are no plans to reduce the transport height of the 40 foot machine. The 1982 machines will, however, be available in a 35-foot size which will be 3 feet shorter. In areas where low overhead lines are prevalent, the 35-foot size may be more practical.
4. The 1982 machines have additional hardware which will prevent the leaking of material between tanks.

NOTE: This report has been prepared using SI units of measurement. A conversion table is given in APPENDIX III.

GENERAL DESCRIPTION

The John Deere 665 central metering seeder is a pneumatic seed and fertilizer applicator designed for use with a John Deere 12.2 m (40 ft) Model 1610 heavy duty cultivator.

The cultivator is attached to the rear of the seeder unit by means of an alternate cultivator hitch which is shorter than a conventional 1610 heavy duty cultivator hitch. The applicator is supported by four castor wheels mounted on tandem walking beam axles.

Seed and fertilizer are pneumatically distributed from two tanks, through a network of tubes to seed boots attached to the rear of each cultivator shank. The applicator can be used for seeding, for combined seeding and fertilizer application, and for fertilizer banding.

Seed and fertilizer are metered through adjustable fluted rolls mounted below the tanks. The meters are driven by chains from a ground drive wheel. A power take-off driven fan forces the metered material through the distribution system. The distribution system consists of a five-port primary header mounted on the applicator, feeding five eight-port secondary headers mounted on the cultivator. Tubes from the secondary headers connect to the seed boots.

The John Deere Model 1610 heavy duty cultivator used was a conventional 12.5 m (41 ft) cultivator with one shank removed to accommodate the number of outlets from five secondary headers. The modified cultivator was 12.2 m (40 ft) wide with a 4 m (13.1 ft) centre frame, 3.9 m (12.7 ft) left wing frame and a 4.3 m (14.1 ft) right wing frame. It was equipped with 40 spring cushioned shanks spaced at 305 mm (12 in), arranged in three rows. The cultivator was equipped with optional three-row mounted harrows. The test machine was also equipped with an electronic monitoring system and an optional loading auger which was hydraulically driven from the tractor hydraulics.

Detailed specifications for the John Deere 665 central metering seeder are given in APPENDIX I while FIGURE 1 shows the location of major components.

SCOPE OF TEST

The John Deere 665 was operated in loam and clay soils in the field conditions shown in TABLE 1 for approximately 101 hours while processing about 840 ha (2075 ac). It was evaluated for quality and rate of work, ease of operation and adjustment, power requirements, safety and suitability of the operator's manual.

TABLE 1. Operating Conditions

CROP	FIELD TILLAGE CONDITIONS	STONE CONDITIONS	FIELD AREA (ha)	HOURS
Barley on stubble	Secondary	Stone free	300	34
Spring wheat on stubble	Primary	Stone free	220	25
Spring wheat on stubble	Primary	Occasional stones	125	15
Winter wheat on stubble	Primary	Occasional stones	15	4
Banding fertilizer	Primary	Occasional stones	180	23
Total			840	101

RESULTS AND DISCUSSION

QUALITY OF WORK

Metering Accuracy: The grain and fertilizer metering system was calibrated in the laboratory¹ and compared with the manufacturer's calibration. Since actual seeding rates for certain settings depended on such things as seed size, density and moisture content, it is not possible for a manufacturer to present charts to include all the varieties of seed. Field calibration checks may be necessary for seed with properties differing from those indicated in the manufacturer's charts. Research has, however, shown that small variations in seeding rates will not significantly affect grain crop yields.

A density meter was supplied with the John Deere 665 to correct meter calibrations for variations in seed density. The density meter supplied was accurate to within about 5% of the Canadian method for determining grain density. The ratio of the standard density to the measured density for the respective seed was multiplied by the rate desired to obtain the corrected rate.

Calibration curves for wheat, barley, oats and rapeseed are given in FIGURES 2 to 5. PAMI's calibration curves are compared to the manufacturer's calibration curves corrected for seed density as described above. At a seeding rate of 80 kg/ha (70 lb/ac), measured rates were 5% lower than the manufacturer's corrected rates in wheat, 2.5% lower in barley and accurate in oats. These differences were considered to be negligible. At a seeding rate of 7 kg/ha (6.2 lb/ac) in rapeseed, the measured seeding rate was 21% higher than the manufacturer's corrected seed rate. At a seeding rate of 3.4 kg/ha (3.0 lb/ac) the measured seeding rate was 53% higher than the manufacturer's corrected rate.

As is shown in FIGURE 6, metering of fertilizer was accurate with little difference between measured and manufacturer's corrected application rates.

The application rate was not significantly affected by field or machine variables. For example, field slope and field roughness had little effect on application rate. An increase in ground speed from 4.8 to 12 km/h (3 to 7.5 mph) caused a decrease in application rate of 4.5% in both wheat and fertilizer. The metering rolls were ground driven. As is common with ground driven equipment, drive wheel slip in very soft fields caused a decrease in application rate of about 4%.

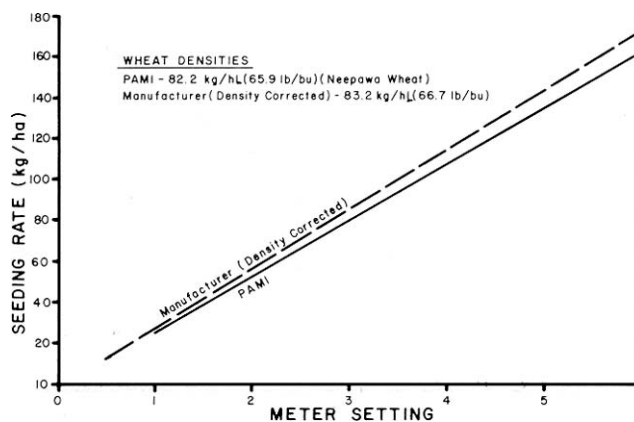

FIGURE 2. Metering Accuracy in Wheat.

¹T773, "Detailed Test Procedures for Grain Drills."

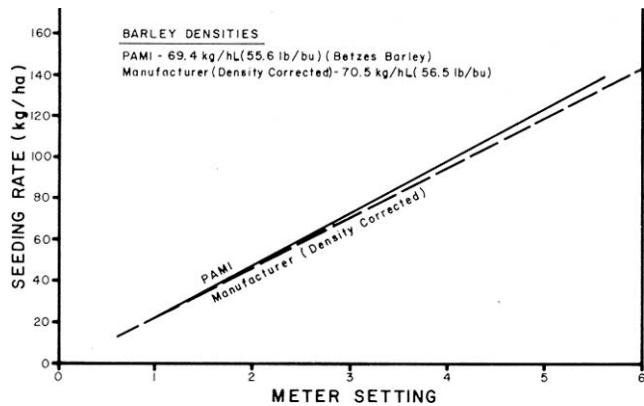

FIGURE 3. Metering Accuracy in Barley.

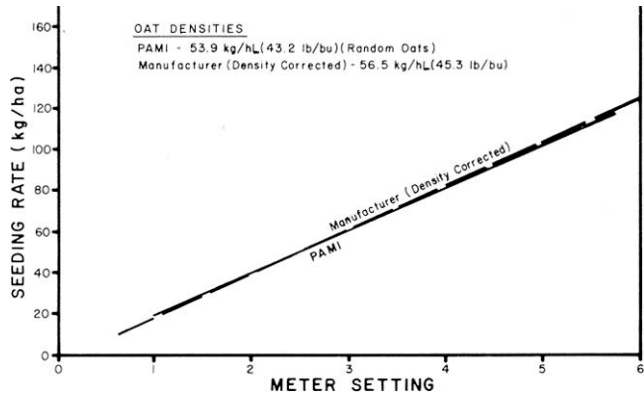

FIGURE 4. Metering Accuracy in Oats.

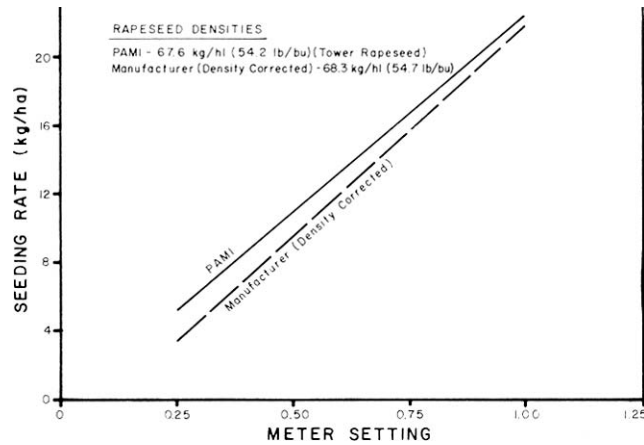

FIGURE 5. Metering Accuracy in Rapeseed.

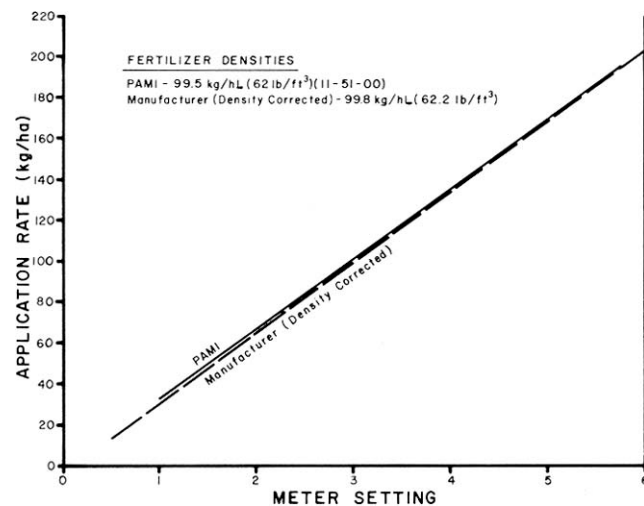

FIGURE 6. Metering Accuracy in Fertilizer.

Distribution Uniformity: The pneumatic distribution system distributed seed uniformly from the metering system to the individual shank boots. FIGURE 7 gives seeding distribution uniformity for the John Deere 665 in wheat, barley and oats. Distribution was uniform over the full range of seeding rates. For example, at a seeding rate of 80 kg/ha (70 lb/ac) the coefficient of variation² (CV) was 6.7% in wheat, 7.9% in barley and 10% in oats. Seeding distribution in rapeseed (FIGURE 8) was also uniform with CV's ranging from 11.5 to 13.5% over the full seeding range. FIGURE 9 shows acceptable distribution uniformity in 11-51-00 fertilizer with a CV ranging from 8.8 to 10.5% over the full application range.

Changes in distribution pattern uniformity could occur at different forward speeds due to different volumes of material being introduced into the constant volume of air supplied by the fan.

Seeding or fertilizing up or down a 10 degree slope or on a 10 degree sideslope had little effect on distribution uniformity.

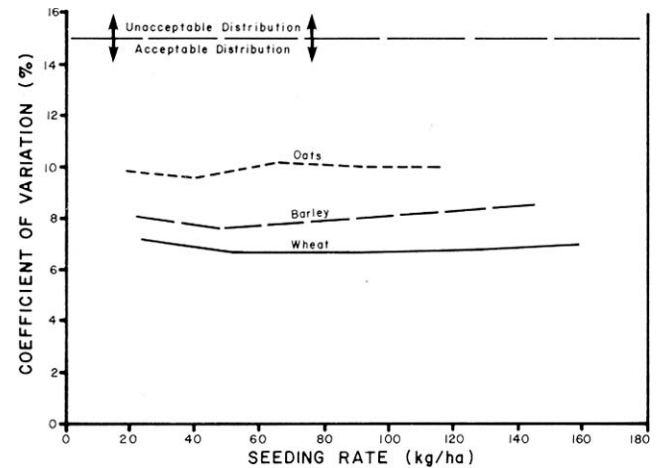

FIGURE 7. Seeding Uniformity in Cereal Grains at 9 km/h.

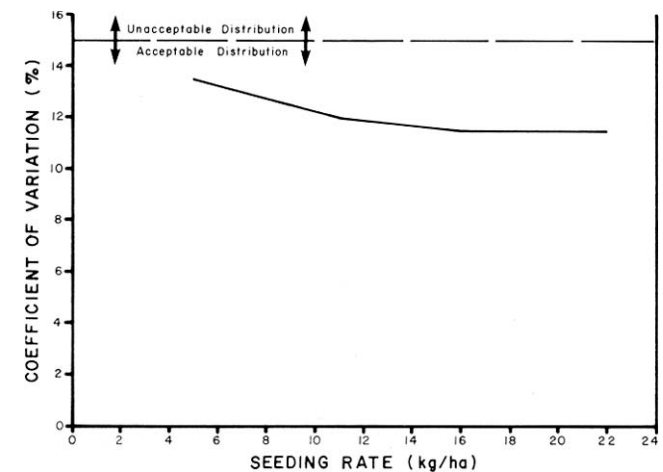

FIGURE 8. Seeding Uniformity in Rapeseed at 9 km/h.

Grain damage: Grain damage by the metering and distribution system for wheat was well within acceptable limits. For example, in dry Neepawa wheat at 11% moisture content only 0.2% creakage occurred. Grain creakage in rapeseed was significantly higher than in cereal grains. For example, in dry rapeseed, at a moisture content of 7%, 3.5% creakage occurred. The John Deere 665 had a fan damper which could be adjusted to reduce the distribution system air velocity. It is recommended that the manufacturer provide a suggested setting for the fan damper to reduce creakage when seeding rapeseed.

²The coefficient of variation (CV) is the standard deviation of seeding rates from individual shanks expressed as a per cent of the average seeding rate. An accepted variation for seeding grain or applying fertilizer is a CV value not greater than 15%. If the CV is less than 15%, distribution is acceptably uniform, whereas if the CV is greater than 15%, the variation in application rate among individual shanks is excessive.

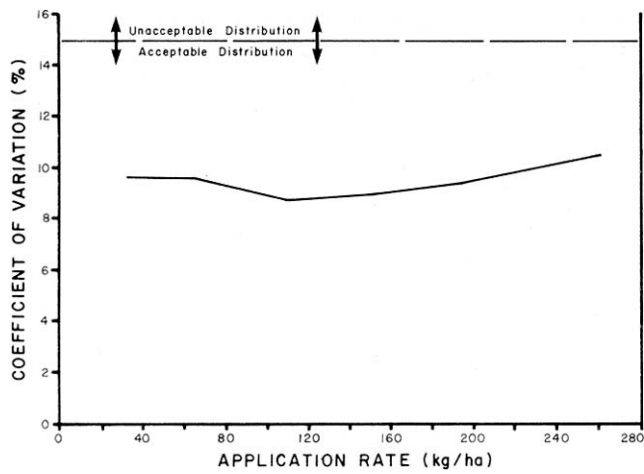

FIGURE 9. Distribution Uniformity in 11-51-00 Fertilizer at 9 km/h.

Seed Placement: Each seed boot consisted of a V-shaped divider with two outlets (FIGURE 10) to spread the seed behind each cultivator sweep. Although rows were visible when grain first emerged, after complete crop emergence, it was difficult to observe distinct plant rows (FIGURE 11). Therefore, even with 305 mm (12 in) cultivator shank spacing, there was sufficient stubble for windrow support at harvest time.

Although seeds were usually placed on the furrow bottom at the working depth of each individual cultivator sweep, depth across the width of the machine varied due to cultivator frame geometry and non-uniform field surfaces. On level and gently rolling fields, vertical seed distribution was quite uniform. For example, at an average seeding depth of 75 mm (3 in), although seeding depth across the width of the machine varied from 40 to 105 mm (1.6 to 4.1 in), most of the seeds were placed within 17 mm (0.7 in) of the average cultivator sweep working depth. This compares to a vertical variation of from 12 to 15 mm (0.45 to 0.6 in) from average seeding depth for a hoe drill in similar conditions.

In fields with sharp hill crests or gullies, seed depth variation became much greater than for a hoe drill, due to the greater distances between shank rows on a heavy duty cultivator than on a hoe drill.

Vertical seed distribution was not adversely affected by field tillage conditions. The shanks on the John Deere 1610 cultivator were sufficiently rigid to maintain a fairly uniform sweep pitch (FIGURE 13), with resultant uniform tillage depth, over a wide range of soil conditions.

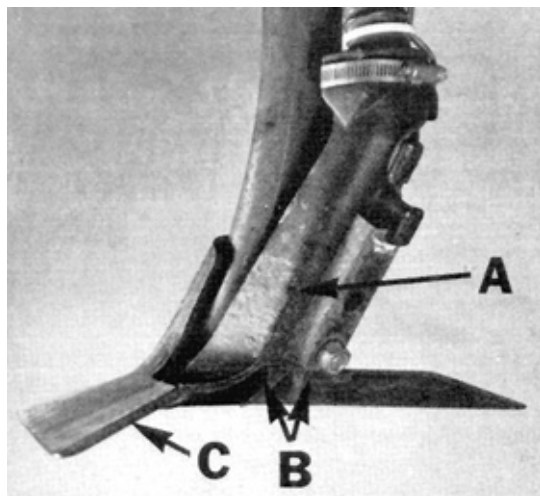

FIGURE 10. John Deere Seed Boot: (A) Seed Boot, (B) Seed Outlets, (C) Sweep.

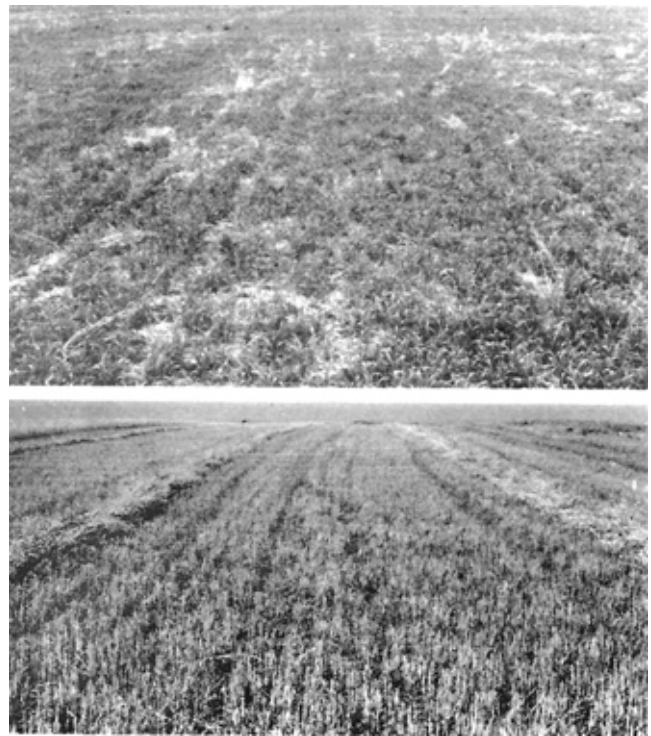

FIGURE 11. Uniform Wheat Emergence in Stubble (Upper: 30 Days after Seeding, Lower: At Harvest).

Plant Emergence: As with most seeding implements, time and uniformity of plant emergence depended on seedbed preparation, soil moisture and seed placement. The John Deere was used to seed in a number of fields with different types of seedbed preparation. Uniform emergence resulted as long as machine settings were carefully adjusted to place seed in moist soil at the correct depth and providing loose seedbeds were packed after seeding. FIGURE 11 shows good emergence when spring wheat was seeded directly into stubble as the first spring operation.

Careful cultivator frame levelling was important in obtaining uniform emergence across the cultivator width. Due to the rigidity of heavy duty cultivator frames, improper sideways levelling and fore-and-aft levelling can both result in rows of shanks operating at different depths.

Seeding Depth: It is very important to seed at the correct depth to obtain uniform seed coverage. Correct cultivator adjustments for pneumatic seeding were best obtained by comparing the depth of seeds placed by several shanks across the cultivator width and from both the front and rear shank rows. This permitted accurate frame levelling to obtain uniform seed coverage. Seeding shallower than 50 mm (2 in) is not recommended for a heavy duty cultivator, due to poor seed coverage and generally poor cultivator performance at shallow tillage depths.

Frame levelling had to be checked and appropriate depth adjustments made when changing fields to ensure adequate, uniform seed coverage. The John Deere 665 cultivator hitch coupled the cultivator closely to the rear of the applicator. Due to the relatively shorter hitch, the cultivator followed the land contours very well.

Soil Finishing: For this evaluation, the John Deere 1610 cultivator was equipped with optional three-row mounted harrows. The mounted harrows were effective in smoothing the soil surface and in breaking soil lumps when adjusted to maximum ground pressure. The harrows also increased weed kill by loosening weeds.

The John Deere 665 was not equipped with packers. Since it was considered essential to pack most fields seeded with the John Deere 665, a harrow-packer drawbar equipped with five bar

tine harrows and trailing steel coil packers³ was used as a follow-up operation.

The harrow-packer combination served to further smooth and pack the seedbed, leaving packer ridges from 20 to 30 mm (0.8 to 1.2 in). To obtain a smooth, firm seedbed in dry conditions required packer drawbar operations in two directions. Care had to be used in moist conditions to avoid over-packing the seedbed. FIGURE 12 shows a typical seedbed after seeding into preworked stubble both before and after use of the harrow-packer drawbar.



FIGURE 12. John Deere 665 Seedbed (Left: Before Packing, Right: After Packing).

Shank Characteristics: The John Deere 1610 cultivator was equipped with adjustable spring cushioned shank holders. During the evaluation, it was used with 406 mm (16 in) wide Wheatland sweeps with a 50 degree stem angle, giving a no-load sweep pitch of 2 degrees. These shanks were very suitable for seeding since sweep pitch (FIGURE 13) varied only 3 degrees over the full range of draft normally expected for a heavy duty cultivator. This resulted in uniform tillage depth and a smooth furrow bottom over a wide range of soil conditions.

Cushioning spring preload, with new shanks, was exceeded at drafts greater than 7.3 kN/m (500 lb/ft), occurring just beyond the normal primary tillage draft range, indicating the John Deere 1610 was suited for heavy primary tillage.

The shanks performed well in stony fields. Maximum lift height to clear obstructions was 210 mm (8.3 in).

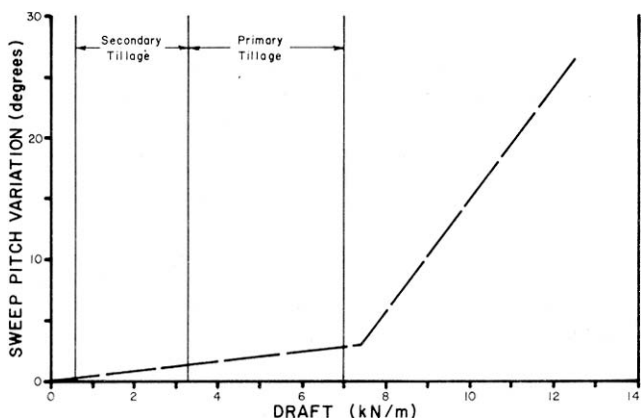

FIGURE 13. Sweep Pitch Variation over a Normal Range of Draft (305 mm Shank Spacing).

Penetration: When equipped with 50 degree, 406 mm (16 in) Wheatland sweeps, penetration was good in nearly all field conditions and it was easy to obtain correct seeding depth. Correct seeding depth could not be obtained in hard conditions such as dry, baked slough bottoms or in fields with abnormally

hard furrow bottoms. Penetration was uniform across the cultivator width provided all depth control linkages and hitch height were kept properly adjusted.

The cultivator wheels were positioned so that each centre wheel supported about 16% of the total cultivator weight while each wing wheel supported about 9%. In addition, each center wheel supported about 13% of the total suction force while each wing wheel supported about 12%. Cultivator or pneumatic seeder sinking was not a problem in moderately soft soils. Since the pneumatic seeder was not supported by the cultivator wheels, but was carried on its own wheels, it did not contribute to cultivator sinking in soft soils.

Trash Clearance: The John Deere 1610 cultivator had excellent trash clearance. The John Deere mounted harrows had to be raised to clear heavy loose trash.

With the harrows properly adjusted it was possible to operate in fields with a heavier trash cover than was possible with a conventional hoe drill.

Skewing and Stability: The John Deere 665 seeder was very stable and sideways skewing occurred only in very hilly conditions. The cultivator shank pattern was symmetrical and did not impose any side forces on the cultivator during normal tillage. When equipped with 406 mm (16 in) sweeps the cultivator had to skew more than 3 degrees to miss weeds. Throughout the evaluation period, in normal seeding conditions, skewing was never serious enough to cause weeds to be missed.

Weed Kill: Weed kill was very good when equipped with 406 mm (16 in) sweeps. The 305 mm (12 in) shank spacing resulted in 100 mm (4 in) sweep overlap. Considerable sweep wear could occur before weeds were missed. However, to ensure adequate sweep lift is maintained for proper placement, sweeps should be replaced before significant wear is evident.

Fertilizer Banding: The John Deere 665 could be used for two types of fertilizer applications. It could be used for normal fertilizer application at seeding time by metering fertilizer from one tank and grain from the other and applying both through the same seed boots. When equipped with chisel points, and alternate banding boots (FIGURE 14), it could also be used for fertilizer banding.

Banding is a relatively new method of fertilizer application on the Prairies. Experimental results suggest that placing fertilizer in compact bands, from 35 mm (1.5 in) below seed depth to twice seeding depth is desirable for fall fertilizer application. This requires the use of chisel points to obtain sufficient depth and minimize soil disturbance and special boots to minimize fertilizer spreading. The John Deere 665 worked well for fertilizer banding. Fertilizer granules were placed in a band about 25 mm (1.0 in) wide. Vertical fertilizer distribution generally ranged from chisel tip depth to 10 mm (0.4 in) above chisel tip depth. Wider fertilizer bands were obtained in lumpy soil conditions and as the chisel points became worn.

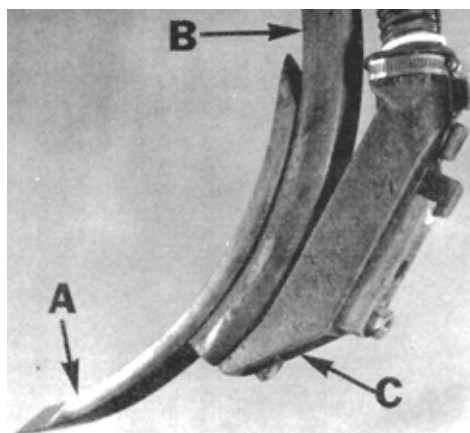

FIGURE 14. John Deere Fertilizer Banding Boot: (A) Chisel Point, (B) Cultivator Shank, (C) Banding Boot.

³See Machinery Institute Evaluation Report 277.

When using both tanks the John Deere 665 was capable of applying 11-51-00 fertilizer at banding application rates up to 262 kg/ha (233 lb/ac) at 9 km/h (5.5 mph). At higher application rates, plugging occurred at the venturi below the meters. Higher application rates were possible at reduced speeds. For example, the application rate could be increased to about 295 kg/ha (262 lb/ac) at 8 km/h (5 mph). When using a single tank, fertilizer rates up to 200 kg/ha (180 lb/ac) were possible with the John Deere 665.

The John Deere 665 meters were very susceptible to moisture entry due to rainfall. FIGURE 15 shows fertilizer caked to the metering flutes after a rainfall. This problem could be avoided by closing the metering shut-off slides above the meters and turning the drive wheel by hand with the fan running to clear the meters after use.

The metering flutes were made of a plastic material for corrosion resistance. All unprotected metal surfaces should be cleaned and oiled periodically, when applying fertilizer, to prevent corrosion.

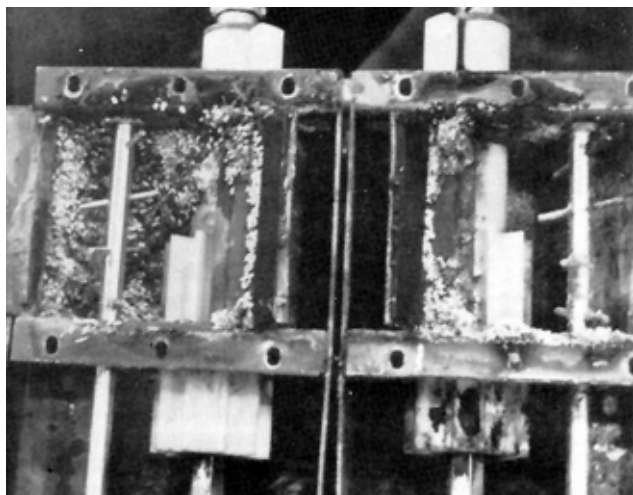

FIGURE 15. Caking of Fertilizer in the Metering System as a Result of Rain Entering the Metering Compartment.

EASE OF OPERATION

Dual Purpose Operation: The John Deere 665 could be detached from the cultivator by two men in about 6 hours. The procedure was inconvenient and included the removal of the alternate cultivator hitch, the monitoring system, the secondary header stands and hoses and installation of a conventional Model 1610 cultivator hitch. This allowed the cultivator to be used as a dual purpose machine, both for seeding and seasonal tillage.

Hitching: The John Deere 665 central metering seeder was easily hitched to a tractor. Hitching convenience was increased by the fact that the hitch link remained horizontal when unhitched from the tractor. Hitching required hook-up of six hydraulic lines with quick couplers, and an electrical connector for the monitoring system. The power take off fan drive required a 1000 rpm, 35 mm (1-3/8 in) power take-off shaft. Therefore hitching to most large tractors required the use of the power take-off adapter supplied. Hitching convenience in soft fields was reduced due to insufficient hitch jack length.

Filling: The optional 152 mm (6 in) loading auger supplied with the John Deere 665 was convenient for filling the tanks (FIGURE 16). Power for the hydraulically driven auger was supplied from the tractor hydraulic system. Auger reversal was prevented by a one-way valve installed on the auger drive. Auger plugging was not a problem throughout the evaluation period.

The auger could be conveniently swung from its horizontal transport position, down to the filling position, by operation of

a hand crank positioned at the center of the auger beside the tank access ladder. The safety screen covering the auger hopper restricted the flow of barley and oats, slightly reducing auger capacity. The auger hopper could be easily inverted for convenient clean-out.

The large 750 x 615 mm (30 x 24 in) grain and fertilizer tank openings gave ample room for auger filling with the directional spout supplied on the auger. Because the filler openings were located 2.8 m (9.2 ft) above the ground, hand filling would be difficult since it would require carrying the grain or fertilizer up the access ladder. The tank lid was mounted on over-center hinges for convenient opening and was latched with a simple swivel latch. The lids were not equipped with weather stripping to prevent moisture entry.

The front tank held 4110 L (113 bu) while the rear tank held 2740 L (75 bu).



FIGURE 16. Optional Loading Auger for Convenient Tank Filling.

Visibility: Visibility of the cultivator mainframe section was obstructed by the tanks. Care had to be observed when operating the John Deere 665 to detect possible problems such as mainframe plugging.

Monitoring System: The test machine was equipped with an electronic material flow sensor system, low bin level indicator and area meter. The monitoring system was easy to use and performed well throughout the evaluation. The flow sensors monitored material flow at the seed or fertilizer boot on each cultivator shank with pin type sensors inserted into the material flow paths. The flow sensor system was activated by turning on the tractor mounted control box power switch. With the control switch in the "alarm" position, both warning beeps and flashing lights indicated material flow stoppage. The exact location of material flow stoppage was identified by banks of lights for both the secondary headers and the 40 individual seed boots. The 665 monitoring system required operator care to maintain correct wire placement along each seed tube and to avoid wire damage.

Meter drive wheel revolutions were monitored by a magnetic pickup and converted to area covered. The electronic area meter read-out was included in the monitoring control box. The low bin level warning light also included in the control box was activated when either tank level was down to refill level.

Seed and Fertilizer Boots: Both seed and fertilizer boots tended to plug in wet conditions encountered around low lying field areas.

Plugging was not considered serious because wet conditions were seldom encountered and the individual flow monitoring at each boot quickly identified any plugging.

Cleaning: Access to the fluted metering rolls for cleaning was possible with full tanks, by closing the tank shut-off slides above each meter. Access to the bottom of the metering rolls was possible by removing the metering venturi tube. This

required the removal of a hose clamp and 4 bolts. Complete meter removal was possible by the removal of an additional 4 bolts and the metering drive chain.

Each tank was equipped with a slide door and a directional spout for convenient tank cleanout. As the cleanout door was located about 80 mm (3.2 in) above the meters, a vacuum cleaner was needed for thorough cleaning of both tanks. Access into the tanks was possible through the filler openings.

Area Meter: The John Deere 665 was equipped with an electronic area meter calibrated in acres. The area meter was accurate and recorded the nearest tenth acre up to one thousand acres. Although no calibration setting for area covered in SI units was given in the operator's manual, the area meter could easily be used to record area covered in SI units simply by providing the appropriate calibration setting. It is recommended that the manufacturer supply the calibration setting for area readout in SI units.

Transporting: A distinct advantage of cultivator mounted pneumatic seeders over conventional drills is the ease with which relatively wide machines can be transported. The John Deere 665 was easily placed in transport position (FIGURE 17) in five minutes. Dual hydraulic cylinders raised the cultivator wings to the upright position. The meter drive wheel lift cylinder was connected with the cultivator lift cylinders and was automatically raised with the cultivator. Each applicator castor wheel was equipped with a stabilizer brake to dampen castor shimmying. The castor wheel brakes were quickly and easily applied for transport by turning a threaded handle on each individual castor wheel.

The John Deere 665 towed well in transport position. Overall transport height and width were 5.3 m (17.4 ft) and 6.4 m (21 ft) respectively, requiring care when travelling on public roads. The transport height was considered excessive and several incidences of contact with overhead lines occurred throughout the evaluation. It is recommended that the manufacturer consider reducing transport height.



FIGURE 17. Transport Position.

EASE OF ADJUSTMENT

Lubrication: Lubrication was convenient with good access to all grease fittings. Five fittings on the applicator and seven on the cultivator required servicing. Five wheels on the applicator and eight on the cultivator required servicing. The fan bearing oil level required seasonal checking. Servicing and service intervals were clearly outlined in the operator's manual.

Application Rate: Application rate was easily changed, using a wrench, by a threaded adjusting screw on each meter (FIGURE 18). A handheld meter scale, adjustable from 0 to 6 in increments of 1/4, was used to determine the amount of exposed flute. Calibration charts, in both kg/h and lb/ac, were located on the applicator tanks as well as in the operator's manual. A different feed gate setting was required for each of cereals, oilseeds and fertilizer, due to differences in particle sizes. The feedgate was set by relocating a bolt to the correct setting for the respective material applied.

Adjusting for precise seeding rates in small grains was somewhat difficult due to the relatively large scale divisions. For example, in Tower rapeseed each 1/4 scale increment changed the seeding rate by about 5.7 kg/ha (5 lb/ac).

Using the density meter supplied with the John Deere 665 to measure grain density, improved accuracy of meter settings for materials of other than standard density. The density meter was accurate to within about 5% of the Canadian method for determining grain density.

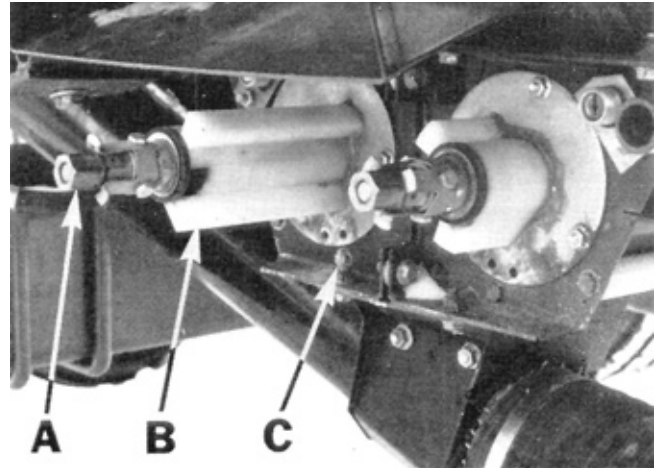

FIGURE 18. Application Rate Adjustment: (A) Threaded Adjusting Screw, (B) Exposed Flute, (C) Feed Gate Adjustment.

Depth Adjustment: Seeding depth was conveniently adjusted with dual mainframe cylinders connected in series to a cylinder on each wing in a master-slave arrangement. All four tandem wheel sets on the cultivator were on walking beam axles, a feature which was considered desirable for keeping the frame level. An adjustable sleeve on one of the dual mainframe depth cylinders could be used to set maximum depth. A wrench was needed to position the depth stop. As is common with series hydraulic systems, to maintain the centre and wing frames at the same height, periodic synchronization of the cylinders, by completely extending them to the fully raised position, was necessary.

The John Deere 665 cultivator frame was leveled from front to back by positioning the hitch stop bolts in one of seven positions and from side to side by adjusting threaded connectors on each wing depth cylinder. These adjustments required the use of tools.

RATE OF WORK

The John Deere 665 was operated at speeds ranging from 5 to 10 km/h (3 to 6 mph). Overall best performance in terms of weed kill and seed placement was obtained at speeds of 8 to 10 km/h (5 to 6 mph), resulting in field work rates for the 12.2 m (40 ft) unit ranging from 9.7 to 12.2 ha/hr (24 to 30 ac/hr). Using both tanks, when seeding wheat at a rate of 85 kg/ha (75 lb/ac), about 60 ha (149 ac) could be seeded before refilling. Using only the larger tank, about 36 ha (90 ac) could be seeded before refilling. This compares to 18 to 28 ha (45 to 70 ac) between refills for most conventional drills of similar widths.

POWER REQUIREMENTS

Fan: The power requirements for the John Deere 665 fan, operating at the recommended power take-off speed of 1000 rpm and fan speed of 6000 rpm, was 9.6 kW (12.9 hp).

Draft Characteristics: Attempting to compare draft requirements of different makes of heavy duty cultivators usually is unrealistic. Draft requirements for the same cultivator, in the same field, may vary by as much as 30% in two different years,

due to changes in soil conditions. Variations in soil conditions affect draft much more than variation in machine make, usually making it impossible to measure any significant draft difference between makes of heavy duty cultivators. The power requirements given in TABLES 2 and 3 are based on average draft requirements of 15 makes of heavy duty cultivators in 56 different field conditions. Additional draft due to the applicator with full tanks and the mounted harrows has been included.

Tractor Size: TABLES 2 and 3 show tractor sizes needed to operate the John Deere 665 in light and heavy primary tillage with the cultivator equipped with 406 mm (16 in) sweeps. Tractor sizes have been adjusted to include tractive efficiency and represent a tractor operating at 80% of maximum power on a level field. The sizes presented in the tables are the maximum power take-off rating as determined by Nebraska tests or as presented by the tractor manufacturer. Selected tractor sizes will have ample power reserve to operate in the stated conditions.

Tractor size may be determined by selecting the desired tillage depth and speed from the appropriate table. For example, in light primary tillage at 75 mm (3 in) depth and 8 km/h (5 mph), a 132 kW (177 hp) tractor is required to operate the seeding unit. In heavy primary tillage at the same depth and speed a 155 kW (208 hp) tractor is needed. Power tests with cultivators equipped with chisel points indicated that tractors suited for seeding in heavy primary tillage conditions will have ample power for banding fertilizer at depths up to 50 mm (2 in) greater than seeding depth.

TABLE 2. Tractor Size (Maximum Power Take-off Rating, kW) to Operate the John Deere 665 in Light Primary Tillage.

DEPTH (mm)	SPEED (km/h)					
	7	8	9	10	11	12
50	85	100	116	134	152	171
75	113	132	151	173	195	218
100	140	163	174	212	239	266
125	168	195	210	252	282	313

TABLE 3. Tractor Size (Maximum Power Take-off Rating, kW) to Operate the John Deere 665 in Heavy Primary Tillage.

DEPTH (mm)	SPEED (km/h)					
	7	8	9	10	11	12
50	79	93	108	124	140	158
75	134	155	180	204	228	254
100	190	219	251	283	316	349
125	245	283	323	362	402	444

OPERATOR SAFETY

The John Deere 665 tank access ladder was convenient and safe. Access to the tank openings required the operator to step over the loading auger when the auger was in transport position.

The auger hopper was covered with a screen. The auger flighting was covered with a steel guard to prevent operator injury if the hopper screen was removed. The auger was lowered and raised to tank loading and transport positions by means of a hand operated crank. If the crank was not held while lowering the auger, the auger could drop, allowing the crank to swing free, resulting in possible operator injury.

Extreme caution is needed in transporting most folding cultivators to avoid contacting power lines. Minimum power line heights vary in the three prairie provinces. In Saskatchewan, the energized line may be as low as 5.2 m (17 ft) over farm land or over secondary roads. In Alberta and Manitoba, the neutral ground wire may be as low as 4.8 m (15.7 ft) over farm land. In all three provinces, feeder lines in farmyards may be as low as 4.6 m (15 ft).

The John Deere 665 transport height of 5.3 m (17.4 ft) exceeded the minimum power line height over farm land or over secondary roads for all three prairie provinces. Clearance problems with overhead lines were encountered frequently when transporting the John Deere 665 throughout the evaluation

period. It has already been recommended that the manufacturer consider reducing the transport height to avoid contact with overhead lines.

The legal responsibility for safe passage under utility lines rests with the machinery operator and not with the power utility or the machinery manufacturer. All provinces have regulations governing maximum permissible equipment heights on various public roads. If height limits are exceeded, the operator must contact power and telephone utilities before moving.

The John Deere 665 was 6.4 m (21 ft) wide in transport position. This necessitated caution when towing on public roads, over bridges and through gates.

A slow moving vehicle sign was provided as standard equipment.

Pins were provided to lock the wings in transport position.

The depth cylinder could be locked in the raised position with the depth adjusting sleeve. This also held the meter drive wheel in the raised position. The meter drive wheel could also be locked mechanically in the raised position by removal of a bolt and reversal of the compression sleeve.

Centre section tire loads on the cultivator in transport position exceeded the Tire and Rim Association maximum load rating for 7.60-15, 6-ply tires by 20%.

The John Deere 665 towed well at speeds up to 28 km/h (17 mph). Castor wheel shimmy was not a problem at transport speeds with empty tanks when the castor stabilizer bars were used.

OPERATOR'S MANUAL

The operator's manual for the John Deere 665 central metering seeder contained useful information on safety, adjustments, assembly, specifications, maintenance and operation. Metering calibration charts, calibrated in both English and SI units were included in the operator's manual. Calibration charts were also printed on a decal placed on the tank above the meters for convenient field reference.

DURABILITY RESULTS

TABLE 4 outlines the mechanical history of the John Deere 665 central metering seeder during 101 hours of operation while processing about 840 ha (2075 ac). The intent of the test was evaluation of functional performance. An extended durability evaluation was not conducted.

TABLE 4. Mechanical History.

ITEM	OPERATING HOURS	EQUIVALENT FIELD AREA (ha)
APPLICATOR		
- An air leak at the primary header connection was sealed at		beginning of test
- The rear meter adjustment threads were damaged and repaired at		beginning of test
- The meter drive wheel assembly was aligned and tightened at		beginning of test
- A defective monitoring system sensor wire was replaced at	6	50
- The tank divider leaked and was repaired at	14	125
- A nut on the auger deflector pivot was lost and replaced at	14	125
- The roll pin fastening the fan pulley to the fan shaft broke and was replaced with a bolt at	48	425
- The fan pulley fit loosely on the shaft. The shaft was built up and machined for a tight fit at	57	500
- A monitoring system sensor wire broke and was repaired at	78	660
- The hitch jack support was straightened at	78	660
- The insert on the power take-off shaft broke and a new power take-off shaft was installed at	78	660
CULTIVATOR		
- The sweeps working in the cultivator and applicator wheel tracks were replaced at	56	465
- All sweeps were replaced at	78	660
- Chisel points and fertilizer banding boots were installed at	78	660
- Chisel points were worn out and inverted at	97	820

DISCUSSION OF MECHANICAL PROBLEMS

APPLICATOR

Meter Adjustment Threads: At the beginning of the test, the rear meter adjuster was bent and the threads damaged. The adjuster was removed, straightened and rethreaded. No more problems with the meter adjustment were encountered throughout the evaluation period.

Tank Divider: The seam joining the tank partitions failed, resulting in material leakage between tanks. Bolts were installed to hold the tank partition joints together (FIGURE 19). It is recommended that tank partition construction be improved to prevent leaking of material between the tanks.

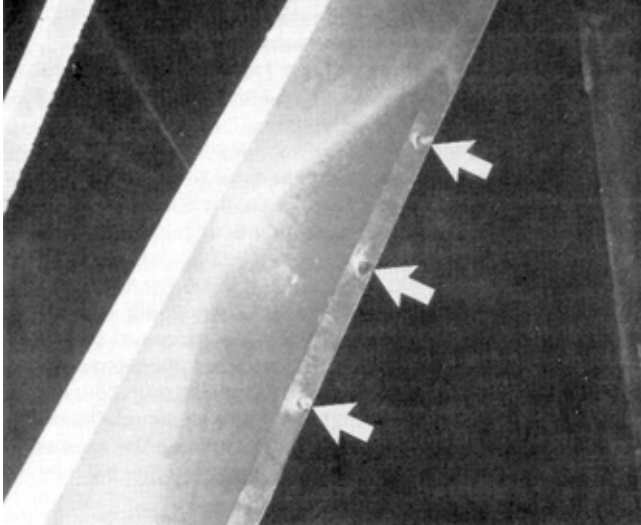

FIGURE 19. Bolts Installed in Tank Partition.

Fan Pulley: The fan pulley fit loosely on the shaft, resulting in fan vibration and eventual failure of the roll pin fastening the pulley to the shaft. The shaft was built up and machined so the pulley fit tightly. The roll pin was replaced with a high strength bolt. No more problems with the fan pulley or fan vibration were encountered throughout the evaluation.

Hitch Jack Support: The hitch jack support was attached with the jack retaining hole in a non-vertical position. This caused the jack to be placed at an angle when supporting the hitch. The support was cut off and rewelded with the retaining hole placed vertically.

Power Take-off: The power take-off shaft was equipped with a non-greaseable insert which fit inside the outer half of the shaft, allowing the inner half to telescope. This insert broke, necessitating replacement of the outer half of the shaft.

APPENDIX I SPECIFICATIONS

(A) APPLICATOR

MAKE:	John Deere
MODEL:	665
SERIAL NUMBER:	000227N
MANUFACTURER:	John Deere Des Moines Works Des Moines, Iowa 50306 U.S.A.
DIMENSIONS:	
- width	4215 mm
- length	6515 mm
- height	2800 mm
- maximum ground clearance	315 mm
- wheel tread	3535 mm
- wheel base	2175 mm
METERING SYSTEM:	
- type	externally fluted feed wheel, non-pressurized tank
- number of meters	2
- drive	chain drive from ground drive wheel
- adjustment	threaded adjustment for area of flute exposure and three feed gate settings
- transfer to openers	pneumatic conveyance through divider headers, hoses and tubes
TANK AGITATOR:	
- type	steel prongs on rotating rod
- drive	gear from meters
TANK CAPACITIES:	
- front	4110 L (113 bu)
- rear	2740 L (75 bu)
Total	6851 L (188 bu)
FAN:	
- type	forward curved centrifugal
- maximum operating speed	6000 rpm
- drive	tractor power take-off
WHEELS:	
- castor wheels	4, 16.5L x 16, 6-ply implement
- meter drive wheel	750 x 16, 4-ply tractor lug
NUMBER OF LUBRICATION POINTS:	
	5 grease fittings 5 wheel bearings
HYDRAULIC CYLINDERS:	
- meter drive lift	1, 95 x 203 mm
HITCH:	
- vertical adjustment range	
- applicator	115 mm in 3 positions
- cultivator	155 mm in 7 positions
OPTIONAL EQUIPMENT:	
- filler auger with or without selector valve	
(B) CULTIVATOR	
MAKE:	John Deere Heavy Duty Cultivator
MODEL:	1610
SERIAL NUMBER:	007607
MANUFACTURER:	John Deere Des Moines Works Des Moines, Iowa 50306 U.S.A.
SHANKS:	
- number	40
- lateral spacing	305 mm
- trash clearance (sweep to frame)	735 mm
- number of shank rows	3
- distance between rows	840, 990 mm
- shank cross section	32 x 50 mm
- shank stem angle	52 degrees
- sweep hole spacing	57 mm
- sweep bolt size	12.7 mm
DEPTH CONTROL:	
	hydraulic
FRAME:	
- cross section	100 mm square tubing, 6.4 mm thickness
TIRES:	
	8, 7.60L x 15, 6-ply implement
NUMBER OF LUBRICATION POINTS:	
	7 grease fittings 6 oiling points 8 wheel bearings
HYDRAULIC CYLINDERS:	
- main depth control	2, 108 x 203 mm
- wing depth control	1, 102 x 203 mm 1, 95 x 203mm
- wing lift	2, 102 x 813 mm
OPTIONAL EQUIPMENT:	
- frame mounted 3-row spring tine harrows	

(C) OVERALL SPECIFICATIONS FOR APPLICATOR-CULTIVATOR ASSEMBLY

DIMENSIONS:	FIELD POSITION	TRANSPORT POSITION
- width	11,995 mm	6425 mm
- length	10,235 mm	10,235 mm
- height	2850 mm	5300 mm
- maximum ground clearance	160 mm	160 mm
- wheel tread	10,600 mm	3285 mm
- effective seeding width	11,995 mm	

WEIGHTS:	TANKS EMPTY	TANKS FULL OF WHEAT
APPLICATOR		
- hitch	540 kg	1530 kg
- left front castor	550 kg	1960 kg
- left rear castor	445 kg	1500 kg
- right front castor	685 kg	1980 kg
- right rear castor	565 kg	1600 kg

CULTIVATOR (WITH MOUNTED HARROWS)	FIELD POSITION	TRANSPORT POSITION
- left centre tandem wheels	1500 kg	2280 kg
- right centre tandem wheels	1500 kg	2280 kg
- left wing tandem wheels	780 kg	
- right wing tandem wheels	780 kg	
Total, Tanks Empty	7345 kg	
Total, Tanks Full of Wheat		13,130 kg

APPENDIX II**MACHINE RATINGS**

The following rating scale is used in PAMI Evaluation Reports:

(a) excellent	(d) fair
(b) very good	(e) poor
(c) good	(f) unsatisfactory

APPENDIX III**CONVERSION TABLE**

1 hectare (ha)	= 2.5 acres (ac)
1 kilometer/hour (km/hr)	= 0.6 miles/hour (mph)
1 meter (m)	= 3.3 feet (ft)
1 millimetre (mm)	= 0.04 inches (in)
1 kilowatt (kW)	= 1.3 horsepower (hp)
1 kilogram (kg)	= 2.2 pounds mass (lb)
1 newton (N)	= 0.22 pounds force (lb)
1 litre (L)	= 0.03 bushels (bu)
1 kilogram/hectare (kg/ha)	= 0.9 pounds/acre (lb/ac)
1 kilogram/hectolitre (kg/hL)	= 0.8 pounds/bushel (lb/bu)
1 kilonewton/meter (kN/m)	= 70 pounds force/foot (lb/ft)



**ALBERTA
FARM
MACHINERY
RESEARCH
CENTRE**

3000 College Drive South
Lethbridge, Alberta, Canada T1K 1L6
Telephone: (403) 329-1212
FAX: (403) 329-5562

<http://www.agric.gov.ab.ca/navigation/engineering/afmrc/index.html>

Prairie Agricultural Machinery Institute

Head Office: P.O. Box 1900, Humboldt, Saskatchewan, Canada S0K 2A0
Telephone: (306) 682-2555

Test Stations:

P.O. Box 1060

Portage la Prairie, Manitoba, Canada R1N 3C5

Telephone: (204) 239-5445

Fax: (204) 239-7124

P.O. Box 1150

Humboldt, Saskatchewan, Canada S0K 2A0

Telephone: (306) 682-5033

Fax: (306) 682-5080