

# Evaluation Report 423

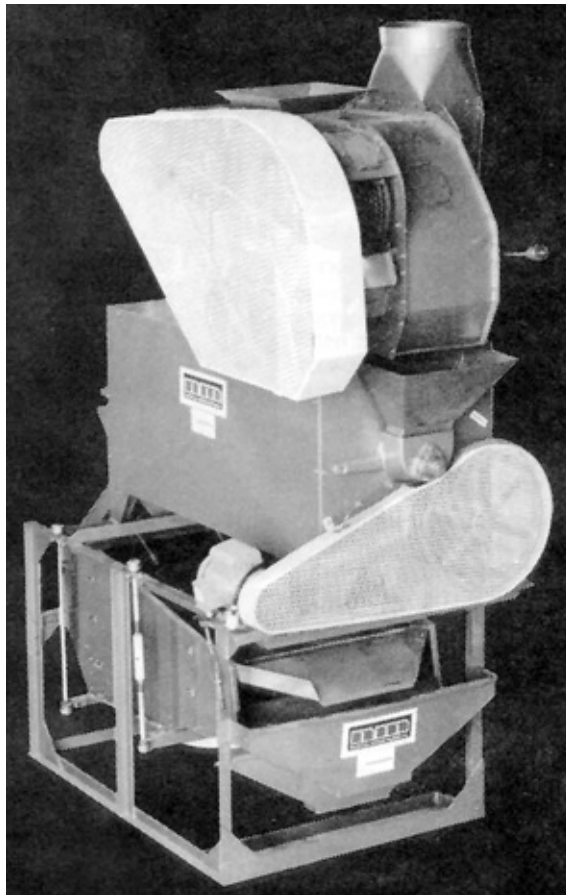

## Berglund Industrial Supply Company Combination Grain and Seed Cleaner

A Co-operative Program Between



ALBERTA  
FARM  
MACHINERY  
RESEARCH  
CENTRE



PRAIRIE AGRICULTURAL MACHINERY INSTITUTE

## BERGLUND INDUSTRIAL SUPPLY CO. COMBINATION GRAIN AND SEED CLEANER

### MANUFACTURER:

Berglund Industrial Supply Co. Ltd.  
600 Norah Crescent  
Box 907  
Thunder Bay, Ontario  
P7C 4X7

### BRANCH OFFICES:

1145C -- 44th Ave. S.E.  
P.O. Box 1446 Station T  
Calgary, Alberta  
T2H 2H7  
408 Gertrude Ave.  
Winnipeg, Manitoba  
R3L 0M6

RETAIL PRICE: \$9,800 (March 1985, f.o.b. Winnipeg, Man.) with motors.

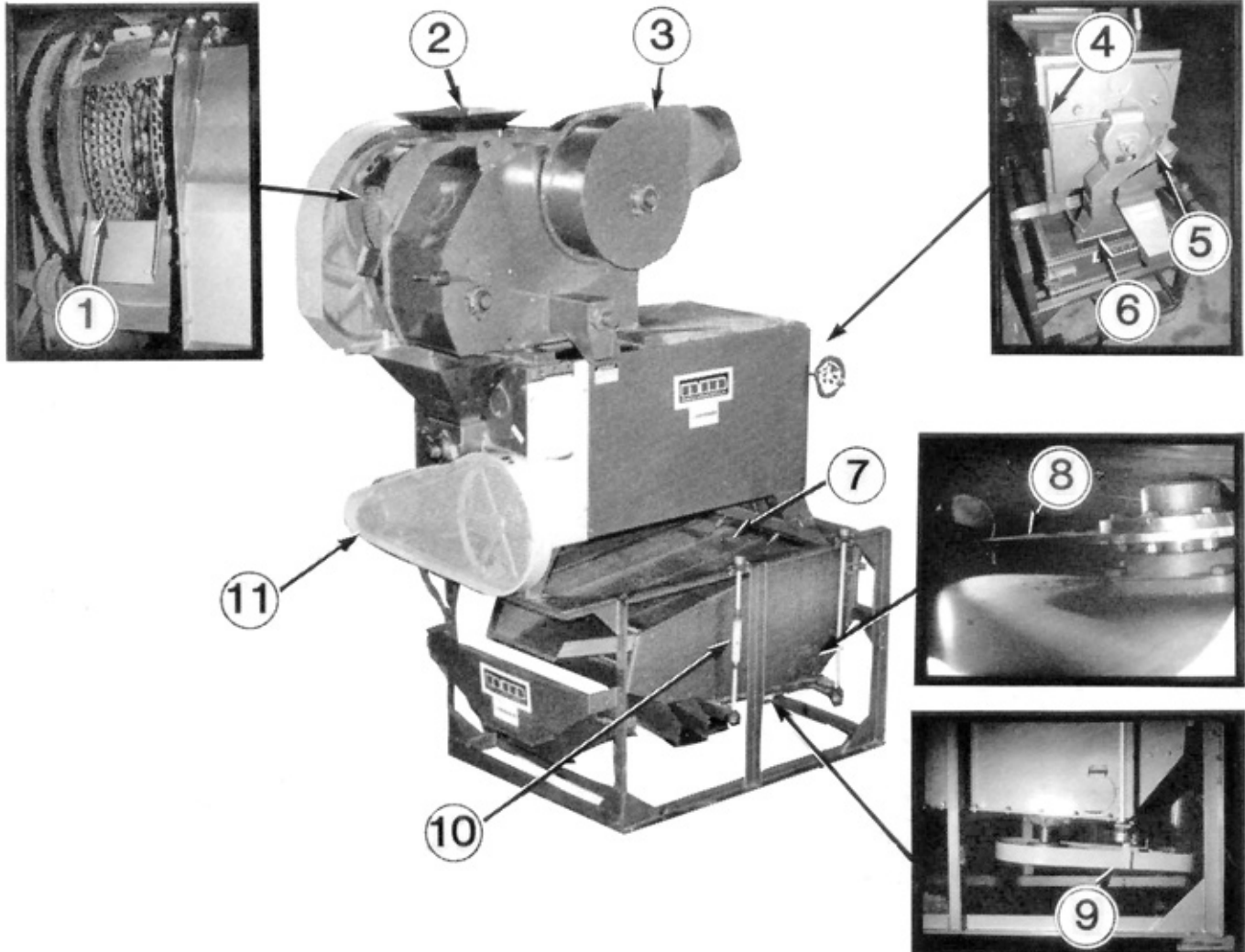

FIGURE 1. Bisco Cleaner: (1) Scalper Disks, (2) Inlet Hopper, (3) Centrifugal Fan, (4) Indent Cylinder Trough Adjustment, (5) Indent Cylinder Retarder, (6) Grain Distributor, (7) Screens, (8) Counter Balance Weight, (9) Eccentric Drive System, (10) Screen Slope Adjustment, (11) Indent Cylinder Drive System.

### SUMMARY

**Quality of Work:** The Bisco Combination Seed Cleaner was effective in removing contaminants from spring wheat, oats and canola. Certified No. 2 grade was obtainable with acceptable losses in screenings. Certified No. 1 status could be obtained if problems such as ergot in wheat, bosom oats and wild oats in oats, and ball mustard in canola were not present or if other machines were used in junction with the Bisco machine.

**Rate of Work:** Capacity of the cleaner varies depending upon the crop, contaminants and grade desired. Best results with the samples tested were obtained with incoming feed rates of 45 bu/h (1.2 t/h) in wheat, 50 bu/h (0.8 t/h) in oats, and 20 bu/h (0.4 t/h) in canola.

**Ease of Operation and Adjustment:** Adjustment of settings such as screen deck slope, air velocity and indent cylinder

trough position were easily accomplished. Approximately 5 to 10 minutes were needed to change the screens.

**Power Requirements:** Two, 3/4 hp (0.56 kW) and one, 1 hp (.75 kW) electric motors were used.

**Operator's Manual:** The manual supplied with the test machine provided an explanation of how the indent cylinder functioned and a parts list. More information concerning operation, adjustment, service and safety was needed.

**Operator Safety:** The Bisco cleaner was safe to operate if normal safety precautions were observed. Extra caution was needed when adjusting the controls of the aspirator on top of the machine.

**Mechanical History:** No durability problems occurred during testing.

## RECOMMENDATIONS

It is recommended that the manufacturer consider:

1. Extending the grain diverters on the screen access door further over the back of the screens to prevent contamination between the screen levels.
2. Providing insulation around the screen access door to prevent grain spillage from the screening section of the machine.
3. Providing set screws on both sides of the screens to lock the screens in place or providing a method of sealing the sides of the screens to prevent contamination between screen levels.
4. Providing a method of fastening the screen frame sections together to allow for easier handling and reduced contamination between screen levels while still facilitating interchanging of the bottom frame section with other screen configurations.
5. Modifying the aspiration controls for easier access.
6. Rewriting the operator's manual to include information on operation, adjustment, safety and service for all sections of the machine.
7. Providing safety decals on the machine to alert the operator of potentially hazardous areas.
8. Modifying the grain distributor door used to spread grain over the top screen to prevent "backlogging" of grain in the distributor.
9. Providing a shield over the screen drive motor to deflect spill grain or providing a totally enclosed motor for the screen drive.

Station Manager: G.M. Omichinski

Project Engineer: C.W. Bolton

## THE MANUFACTURER STATES THAT

With regard to recommendations:

- 1 to 4. A new screen clamping device has been designed to eliminate the fastening of the screens to the frame and tightening the frame to the deck. At the same time, it will allow the customer to purchase and stock the sieve material only, and not have the need for frames. The adaptation also eliminates the need for a filler plate and diverter, therefore, preventing leakage from the unit's interior and exterior.
5. Recommendation #5 has now been corrected to have the feed control rod at the top of the sieve unit approximately 4 feet above ground level.
6. Currently we are re-working the manual to include operating instructions and parts lists. This will be forwarded upon completion.
7. As it is our practice to guard all moving parts, we have never used safety decals, but we will look into a safety warning sign to post on the unit, and also note it in the manual.
8. This item has been changed to a weighted door that has an overflow opening to prevent any choking or plugging of the cylinder unit.
9. This has been done on our latter built units as this item was brought to our attention earlier.

## GENERAL DESCRIPTION

The Bisco Combination Seed Cleaner is a solidly constructed, small capacity grain cleaner incorporating three cleaning sections. Each section can be removed from the machine and operated separately. Grain is separated by weight, width and length. These functions are performed by scalper disks, a fan, an indent cylinder and two different screenings (FIGURE 1).

Instead of using brushes to prevent material from collecting in the screens, hard 1-3/8in (35 mm) diameter rubber balls are used inside a two piece sectional frame (FIGURE 2). The bottom half is interchangeable with other screen configurations. There are 24 sections when the frame is fitted together with 3 of the elastic rubber balls in each section.

Unclean grain is fed into the inlet hopper (FIGURE 3). As grain flows through the scalper disks, coarse materials such as long

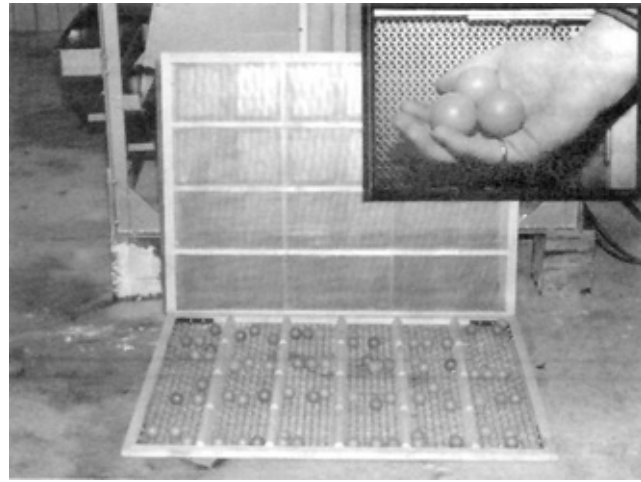

FIGURE 2. Screen Frame

straw and unthreshed heads are removed. The grain is transferred across the machine in a covered auger with a counter balanced door on the bottom. The weight of the grain opens the door creating a "shower" of grain. The fan draws air through the "shower" removing chaff, hulls and light kernels of grain. The heaviest material lifted from the grain settles in a chamber and the chaff is carried out the air duct.

The indent cylinder has "pockets" which pick up good grain and lift it into a trough. Long weed seeds such as wild oats are not picked up and are discharged out the end of the cylinder. Grain is then spread onto the top large hole screen. The eccentric motion and slope of the screen causes the grain to move down the screen. Coarse material and oversized kernels of grain flow the entire length of the screen as small material and good grain fall through. On the second smaller hole screen the small material falls through leaving the finished product to be gathered at the end of the screen.

A small amount of good grain is expected to be lost with the screenings in each operation. Aisc, this machine does not include all possible cleaning operations and is not designed to remove all types of contaminants from every type of grain.

Detailed specifications are given in APPENDIX I.

## SCOPE OF TEST

The Bisco seed cleaner was operated for approximately 75 hours while cleaning red spring wheat, oats, and canola seed. Certified seed was mixed with known quantities of screenings, chaff, wild oats and small weed seeds. The mixture was cleaned by the test machine. The machine was evaluated for quality of work, rate of work, ease of operation and adjustment, power requirements, suitability of the operator's manual and operator safety.

## RESULTS AND DISCUSSION

### QUALITY OF WORK

Before the cleaning operation begins, the operator should determine the quality of the uncleaned sample, the grade standard to be met, the acceptable level of screenings and the time available for cleaning the grain.

**Scalper Disks:** The scalper disks were used as a pre-cleaner to remove coarse material from wheat and oats such as unthreshed heads and straw. The performance of the two slotted scalper disks was good.

**Aspiration:** The ability of the aspiration system to remove chaff, hulls and light kernels of grain from the sample was very good. Although the fan could lift kernels of wheat from the sample, careful adjustment of the controls kept good grain losses to a minimum.

**Indent Cylinders:** Trough settings and retarder position of the indent cylinders were critical in obtaining optimum results.

Nearly all wild oats were eliminated from Columbus Wheat with minimal grain loss using the # 18 indent cylinder. General performance of this indent cylinder was very good.

<sup>1</sup>See APPENDIX II for detailed composition of test material.

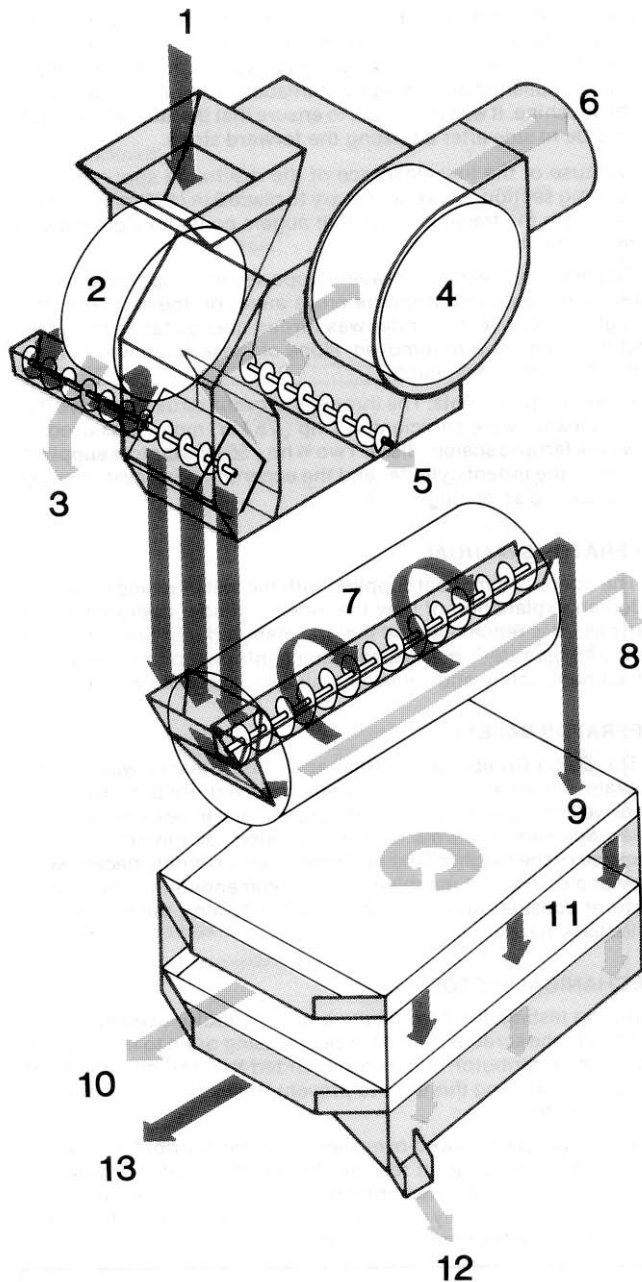

**FIGURE 3.** Material Flow Diagram: (1) Inlet Hopper, (2) Scalper Disks, (3) Large Coarse Material, (4) Fan, (5) Light Material, (6) Chaff, (7) Indent Cylinder, (8) Long Material, (9) Large Screen, (10) Coarse Material, (11) Small Screen, (12) Fine Material, (13) Clean Grain.

**Screens:** After trying several sizes of screens, the problems of removing wild buckwheat from Columbus Wheat and green foxtail from Regent Canola still persisted. Better screen selection or increased aspiration (with an increase in screenings) might have alleviated these problems.

A small amount of recontamination from the top screen and grain losses from the bottom screen did affect performance. To prevent grain loss at the front of the screens, the operator could push the screens forward. However, this created a "gap" between the screen access door diverters and the back of the screens shown in FIGURE 4. Some grain also "leaked" out around the access door. It is recommended that the manufacturer consider extending the screen access door diverters and providing insulation around the edge of the screen access door.

Losses also occurred on the sides of the screens. The screens were locked in place by set screws on one side of the machine. No method of sealing the sides of the screens was used to prevent losses, particularly on the locking side where the screens were pushed away from the side by the set screws. It is recommended the manufacturer consider providing set screws on both sides of the screens or providing a method of sealing the screen area.

Also the screen frames had a tendency to separate while in the machine (FIGURE 4) as there was no method of locking the two parts of screen frame together. This added to the grain toss problem and made handling of the screens more difficult. It is recommended that the manufacturer consider providing a method of fastening the screen frames together while still providing easy interchanging of the bottom part of the frame with other screen configurations.

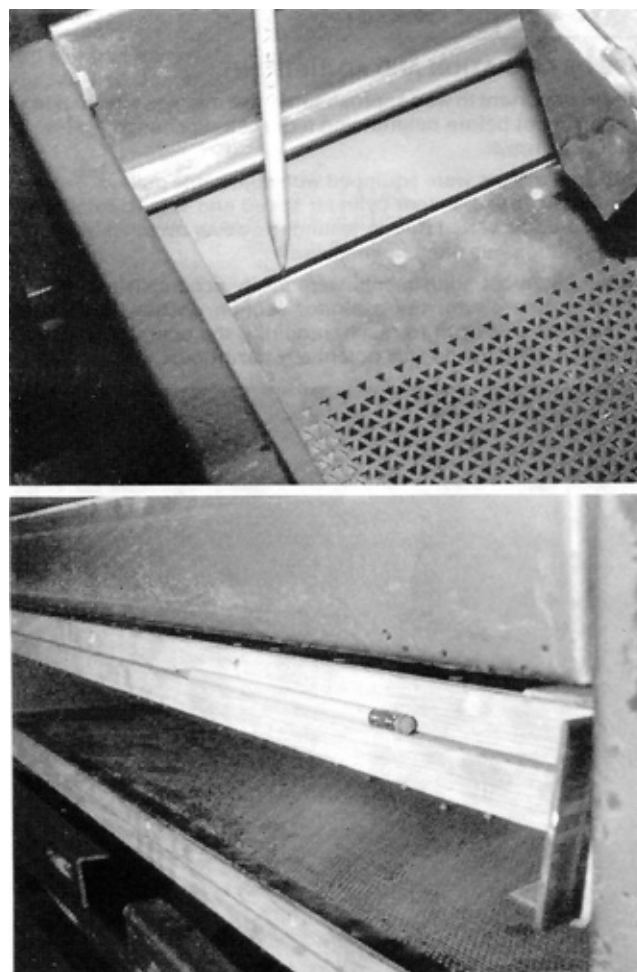

**FIGURE 4.** Screen Frame Positioning and Separation.

**General Performance:** Certified No. 2 seed was produced from all three test samples of spring wheat, oats and canola. Certified No. 1 seed could have been produced if certain elements indicated below were not present or if other machines were used in conjunction with the test machine.

The seed regulations are very strict about the amount of ergot in wheat. The Bisco cleaner eliminated most of the ergot but not enough for Certified No. 1 status. A very small percentage of white caps were also seen in the finished sample but this did not affect the grade.

A large percentage of bosom oats (one oat inside another) were left in the oat sample. These seeds could have been knocked apart with another cleaning machine (e.g. Buffer). Wild oats in oats is considered to be an inseparable operation. The Bisco cleaner reduced the amount of wild oats in oats, but not to seed standard and at the expense of over 50% loss to screenings.

The test sample of canola contained a large amount of ball mustard which is very difficult to remove. However, a Certified No. 2 sample was still obtainable with considerable adjustment.

#### RATE OF WORK

The capacity of the machine was dependent upon various factors. These included the type of crop cleaned, contaminants in the sample, the grade desired and the screen configurations selected.

TABLE 1 shows the maximum rates for wheat, oats and canola that achieved Certified No. 2 results with the samples of grain cleaned. Cleaner bin samples could be processed at higher rates.

Quality was adversely affected at rates above those indicated and when rates were reduced by more than 30%.

TABLE 1. Cleaning Rates

Crops	Incoming Rates	Outgoing Rates
Wheat	45 bu/h (1.2 t/h)	35 bu/h (1.0 t/h)
Oats	50 bu/h (0.8 t/h)	40 bu/h (0.6 t/h)
Canola	20 bu/h (0.4 t/h)	10 bu/h (0.2 t/h)

**EASE OF OPERATION AND ADJUSTMENT**

It was important to wait approximately five minutes after making an adjustment before determining if the setting change achieved the desired result.

All three motors were equipped with adjustable pulleys. Therefore the fan speed, indent cylinder speed and screen rotational speed could be varied during testing. However an adjustment in speed settings was often not necessary.

Generally most adjustments were easily accomplished. However, the controls on the aspirator section on the top of the machine were difficult to reach, requiring the operator to use a ladder (FIGURE 5) and was potentially hazardous.



FIGURE 5. Adjusting Aspirator Controls.

It is recommended that the manufacturer consider modifying the aspirator controls for easier access. The volume of air, the draft and the amount of grain falling from the covered cross auger could be controlled.

Two adjustments could be made on the indent cylinder. By turning a small hand wheel, the trough position could be changed to catch grain of different length (e.g. long wild oats in wheat). An easily adjusted retarder at the end of the indent cylinder was used to maintain a "bank" of grain in the bottom of the cylinder. If set too low, too much grain would be lost.

To change screens the back of the screener section and the screenings spout from the indent cylinder had to be removed. Set screws on one side of the machine were then loosened and the screens pulled out. The screens did not slide easily from the machine, partially due to grain in the screen track and the screen

frames separating. Previously recommended modifications to reduce leakage around the screens and screen frame separation would improve the screen changing task. Variation in screen slope was accomplished by turning two threaded rods, one on each side of the machine. It was important to ensure that the screen was level from side to side after adjusting the forward slope.

Because of the low clearance of the discharge spouts on the screening section, it was necessary to place 6 in (150 mm) blocks, underneath the frame in order that augers could take grain away from the machine.

To clean the machine between crops several steps were taken. Grain was vacuumed from the cross auger on the aspirator, the trough in the indent cylinder was turned over as far as possible, and the screens were removed. None of these steps were overly difficult or time consuming.

**Power Requirements:** The three electric motors used to drive the Bisco cleaner were sufficient. A 1 hp (0.75 kW) motor was used to drive the fan and scalper disks. Two 3/4 hp (0.56 kW) motors supplied power to the indent cylinder and the eccentric drive system used to vibrate the screening section.

**OPERATOR'S MANUAL**

The operator's manual supplied with the test machine only provided an explanation of how the indent cylinder operated and a parts list. It is recommended that the manufacturer consider providing an operator's manual containing information on operation, adjustment, safety and service for all sections of the machine.

**OPERATOR SAFETY**

The Bisco Combination Grain and Seed Cleaner was safe to operate if normal precautions were observed. Belts and pulleys were well shielded. However, the operator had to be extra cautious when adjusting controls on the aspirator section (FIGURE 5) because of the height of the machine. Also, no safety decals were provided on the test machine. It is recommended that the manufacturer consider providing safety decals to alert the operator of potentially hazardous areas.

**MECHANICAL HISTORY**

During testing, the door on the grain distributor used to spread grain over the screens, failed to open causing grain to flow out the top of the distributor. It is recommended that the manufacturer consider modifying this door to prevent "backlogging" of grain in the distributor.

When the grain flowed over the top of the distributor or when removing screens, grain fell into the electric motor driving the screening section. It is recommended that the manufacturer consider providing a totally enclosed motor or a shield over the top of the motor to deflect grain when spillage occurs.

**APPENDIX I**

**SPECIFICATIONS**

**MAKE:** Berglund Industrial Supply Company

**MODEL:** Bisco Combination Grain and Seed Cleaner

**OVERALL DIMENSIONS:**

-- width	4.0 ft (1.2 m)
-- length	7.3 ft (2.2 m)
-- height	6.8 ft (2.7 m)
-- mass	1780 lb (808 kg)

**DRIVES:**

-- three electric motors	2	0.75 hp (0.56 kW)
	1	1.00 hp (0.75 kW)

**LUBRICATION:**

-- sealed bearings are used

**SCALPER DISKS:**

-- diameter	18 in (457 mm)
-------------	----------------

**GRADER SCREENS:**

-- width	32 in (813 mm)
-- length	42 in (1070 mm)
-- slope range	4° - 10°

<b>INDENT CYLINDER:</b>	
-- diameter	21.0 in (533 mm)
-- length	52.0 in (1320 mm)
<b>NUMBER OF PULLEYS:</b>	12
<b>NUMBER OF CHAINS:</b>	1
<b>NUMBER OF BELTS:</b>	4 Link belts 2 V-belts
<b>NUMBER OF DISCHARGE CHUTES:</b>	7
<b>OPTIONAL EQUIPMENT:</b>	
-- various acreens	
-- various indent cylinders	

APPENDIX II		
<b>TEST SAMPLE COMPOSITIONS:</b>		
<b>Wheat:</b>	82.5%	-- Certified No 1 Spring Wheat
	150%	-- Screenings (cracked wheat, small weed seeds, whole grain chaff, ergot, unthreshed heads)
	2.0%	-- wild oats
	0.5%	-- wild buckwheat
<b>Oats:</b>	70.0%	-- Certified No. 2 Fidler Oats
	30.0%	-- Screenings (chaff, light oats, whole oats, bosom oats, wheat, small weed seeds)
<b>Canola:</b>	80.0%	-- Certified No 2 Regent Canola
	20.0%	-- Screenings (hulls, ball mustard, whole canola, wheat, small weed seeds, straw, pods)

APPENDIX III	
<b>MACHINE RATINGS</b>	
The following rating scale is used in PAMI Evaluation Reports:	
Excellent	Fair
Very Good	Poor
Good	Unsatisfactory

**SUMMARY CHART**  
**BERGLUND INDUSTRIAL SUPPLY CO.**  
**COMBINATION GRAIN AND SEED CLEANER**

<b>RETAIL PRICE:</b>	\$9,800 (March 1985, f.o.b. Winnipeg, Man.)
<b>QUALITY OF WORK:</b>	
Light Material Removal	Very Good
Small Material Removal	Good
Large Material Removal	Very Good
<b>RATE OF WORK:</b> (Incoming Rates)	
Wheat	45 bu/h (1.2 t/h)
Oats	50 bu/h (0.8 t/h)
Canola	20 bu/h (0.5 t/h)
<b>EASE OF OPERATION:</b>	
Settings	Good
Screen Changes	Good
Cleanout	Good
<b>POWER REQUIREMENTS:</b>	
Electric Motors:	2 - 3/4 hp (0.56 kW) 1 - 1.0 hp (0.75 kW)
<b>OPERATOR SAFETY:</b>	Good
<b>OPERATOR'S MANUAL:</b>	Poor
<b>MECHANICAL HISTORY:</b>	-- Grain distributor from indent cylinder to screen frequently failed to open -- Slight separation of screen frames.



**ALBERTA FARM MACHINERY RESEARCH CENTRE**

3000 College Drive South  
Lethbridge, Alberta, Canada T1K 1L6  
Telephone: (403) 329-1212  
FAX: (403) 329-5562  
<http://www.agric.gov.ab.ca/navigation/engineering/afmrc/index.html>

**Prairie Agricultural Machinery Institute**

Head Office: P.O. Box 1900, Humboldt, Saskatchewan, Canada S0K 2A0  
Telephone: (306) 682-2555

Test Stations:	P.O. Box 1150
P.O. Box 1060	Humboldt, Saskatchewan, Canada S0K 2A0
Portage la Prairie, Manitoba, Canada R1N 3C5	Telephone: (306) 682-5033
Telephone: (204) 239-5445	Fax: (306) 682-5080
Fax: (204) 239-7124	