

Evaluation Report 341

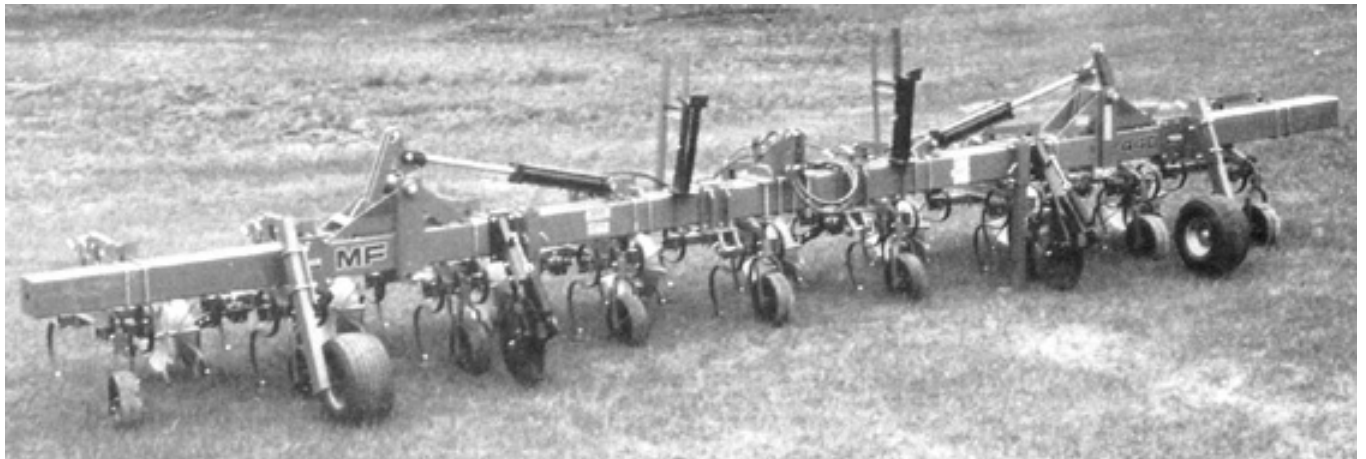

Massey Ferguson 440 Row Crop Cultivator

A Co-operative Program Between



ALBERTA
FARM
MACHINERY
RESEARCH
CENTRE



PRAIRIE AGRICULTURAL MACHINERY INSTITUTE

MASSEY FERGUSON 440 ROW CROP CULTIVATOR

MANUFACTURER:

Massey Ferguson Industries Ltd
915 King Street West
Toronto, Ontario
M6K 1E3

DISTRIBUTOR:

Massey Ferguson Industries Ltd
2615 Barlow Trail S.E
Box 1340, Station T
Calgary, Alberta
T2H 2J1

RETAIL PRICE: \$7,771.90 (January 1984, f.o.b. Portage la Prairie, Manitoba) 8-row, 36 inch (900 mm) spacing with rolling shields, support wheels, guide coulters, crank adjust gauge wheels, and 4 in (100 mm) sweeps.

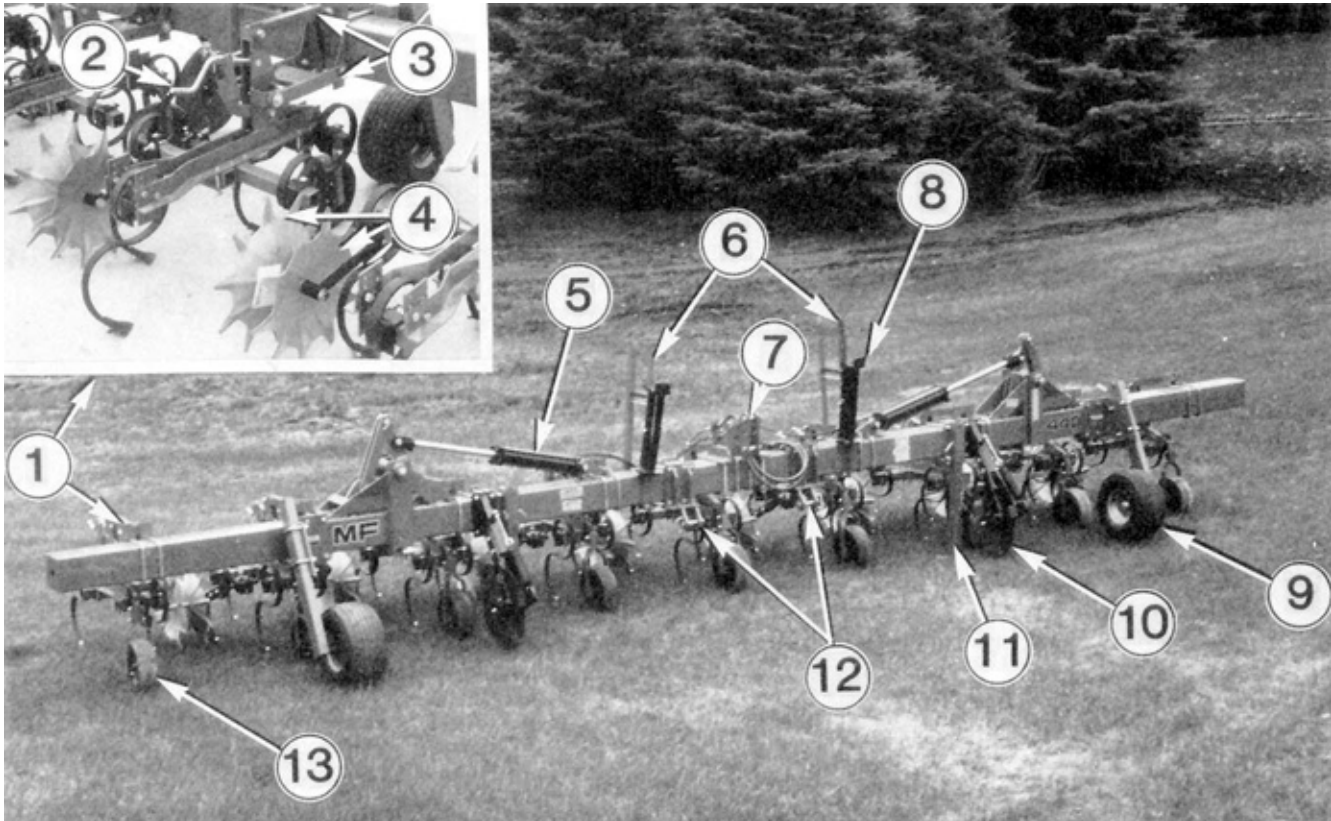

FIGURE 1. Massey Ferguson 440: (1) Gangs, (2) Crank Adjustments, (3) Parallel Linkage (4) Rolling Shields, (5) Wing Lift Cylinders, (6) Wing Transport Braces, (7) Upper Hitch Mast, (8) Cylinder Stops, (9) Support Wheels, (10) Guide Coulters, (11) Parking Stands, (12) Lower Hitch Points, (13) Gauge Wheels.

SUMMARY AND CONCLUSIONS

Overall Performance: The overall performance of the Massey Ferguson 440 row crop cultivator was good.

Quality of Work: Weed kill was good with 4 in (100 mm) sweeps, Penetration was good in average field conditions, with the tines having enough flexibility to provide high speed vibrations for crust shattering, and clearance over large stones.

Trash burial in light and moderate trash was good, In areas of heavy trash, the gangs tended to collect the trash and plug. This caused the gang to push the soil instead of tilling it. Skewing occurred where soil hardness varied across the machine width.

Ease of Operation and Adjustment: The Massey Ferguson 440 could be easily folded into transport or field position from the tractor seat. The wings folded 180 degrees and had pins to hold them in place, The 11 in (280 mm) sweep-to-ground clearance was adequate for normal transport. Transporting on public roads required caution because of the machine's large transport width. The cultivator was sturdy during field work and in transport.

Tillage depth was usually even across the cultivator width

except where the ground was packed hard from the tractor wheels. Fore-and-aft and lateral levelling was accomplished on the three-point hitch of the tractor. One man could hitch or unhitch the cultivator in about 6 minutes.

Power Requirements: Total draft (pull force) under average row crop conditions at 5 mph (8 km/h) varied from 1365 to 2400 lb (6.1 to 10.7 kN) for depths of 2 to 4 in (50 to 100 mm) respectively Under average soil conditions, at 6.0 mph (10 km/h) and 4 in (100 mm) depth, the draft power requirement was 72 hp (54 kW). A tractor of about 120 hp (89 kW) was required for safe overall operation of the Massey Ferguson 440.

Durability: No mechanical problems developed during the 131 hours of field operation.

RECOMMENDATIONS

It is recommended that the manufacturer consider:

1. Making available a stiffer tine or a tine helper spring as an option to provide extra penetration force where required.

Senior Engineer -- G.M. Omichinski

Project Engineer -- D.J. May

THE MANUFACTURER STATES THAT

With regard to recommendation number:

1. We have no record of customer complaints in this regard, but we will investigate more thoroughly and develop an attachment or optional construction to correct the situation, if it proves to be necessary.

GENERAL DESCRIPTION

The Massey Ferguson 440 evaluated was a mounted, folding, eight-row, row crop cultivator suitable for light tillage, and chemical incorporation in row crops with 30 to 40 in (760 to 1020 mm) row spacing. There were five gangs on the centre section, and two gangs on each of the wings. Each of the inner gangs had five tines, while the two outer gangs had three tines each. The test machine was equipped with 4 in (100 mm) sweeps and rolling shields.

FIGURE 1 shows the location of the major components. Support and guidance are controlled by the two support wheels on the wings and the disc coulters on the centre section respectively. The wings fold into transport position by means of a hydraulic cylinder above each end of the centre section of the tool bar. A tractor with single remote hydraulic controls, and a Category II or III three-point hitch is required to operate this cultivator.

Detailed specifications are given in APPENDIX I.

SCOPE OF TEST¹

The Massey Ferguson 440 was operated under field conditions as shown in TABLE 1 for 131 hours, while cultivating 1220 ac (494 ha). It was evaluated for quality of work, ease of operation and adjustment, power requirements, operator safety, and suitability of the operator manual.

TABLE 1. Operating Conditions

FIELD CONDITION	OPERATING HOURS	EQUIVALENT FIELD AREA* ac (ha)
Soil Type:		
— sand	16	150 (61)
— sandy loam	42	390 (158)
— loam	43	400 (162)
— clay loam	30	280 (113)
TOTAL	131	1220 (494)
Crop:		
— corn	116	1080 (437)
— sunflowers	15	140 (57)
TOTAL	131	1220 (494)

*EQUIVALENT FIELD AREA includes two to three successive cultivations on the same field. Duration between cultivations was about two weeks.

During the test only a few small stones were encountered. They did not have a significant effect on the test. The cultivator was transported over 100 mi (161 km) on paved roads and 130 mi (209 km) on gravelled roads.

RESULTS AND DISCUSSION

QUALITY OF WORK

Tine/Sweep characteristics: There is a large variation in tine and sweep stem angles (FIGURE 5) on cultivators from different manufacturers. Sweeps and tines must be matched to obtain sufficient sweep pitch to achieve and maintain penetration. To achieve this, manufacturers usually recommend the use of sweeps with a stem angle from 0 to 5 degrees less than the tine stem angle.

Sweep pitch increases in proportion to draft, due to the deflection of the tine (FIGURE 3). A small positive sweep pitch provides uniform tillage depth and a smooth furrow bottom, while excessive sweep pitch causes furrow ridging and rapid sweep wear.

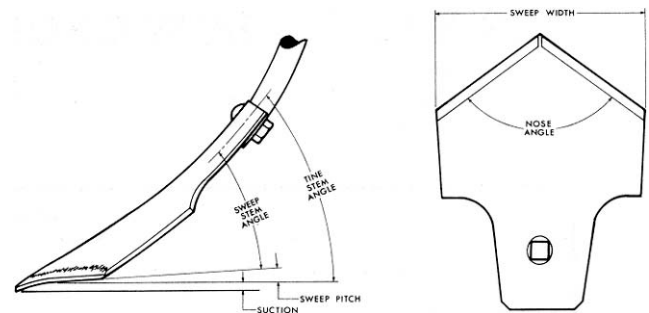

FIGURE 2. Tine and sweep terminology.

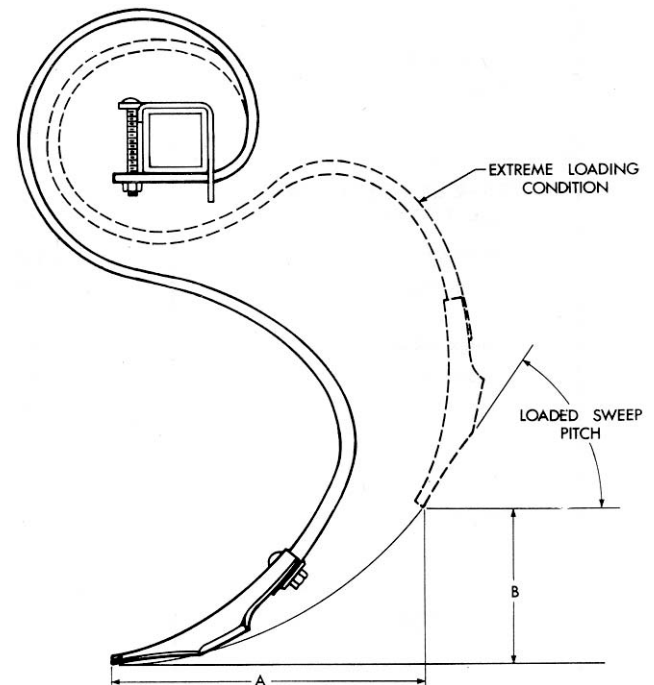

FIGURE 3. Schematic showing the increase in sweep pitch with increase in draft. This also illustrates the relative movement of a tine as it passes over an obstruction. (A) 10 in (250 mm), (B) 4 in (100 mm).

The force/deflection characteristics of the S-tine on the Massey Ferguson 440 are presented in FIGURE 4. In general, the high speed vibrating action of the S-tines provided effective weed kill, crust shattering and soil levelling.

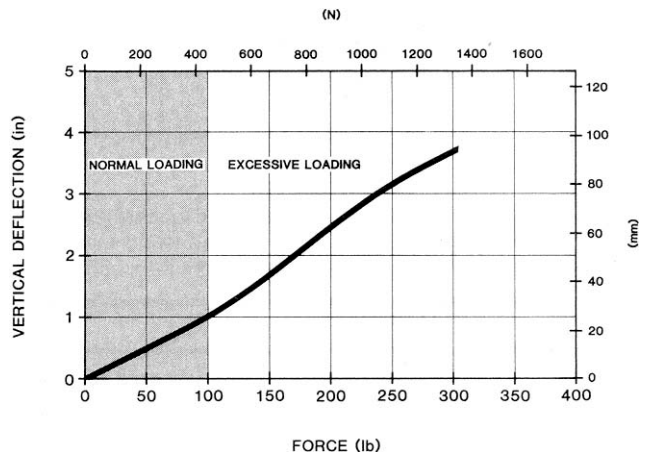

FIGURE 4. Tine deflection characteristics. (Excessive loading can occur in very hard soil or when contacting obstructions such as rocks).

Penetration: Penetration was good under average field conditions. However, penetration was not always uniform across the

¹Prairie Agricultural Machinery Institute Detailed Test Procedures for Row Crop Cultivators.

cultivator width. The cultivator tines behind the tractor and implement wheels tended to ride on top of hard soil, packed by these wheels. It is recommended that the manufacturer consider making available a stiffer tine or a tine helper spring as an option to provide extra penetration force where required.

Uniform penetration also depended on the levelness of the cultivator. The wings could be kept rigid with the centre section by means of locking pins at the hinges, or left to float when operating on hilly land, permitting the gangs to operate at the proper working height.

Trash Effects: The Massey Ferguson 440 plugged occasionally in row crop conditions of moderate or light trash (residue corn stalks and weeds) and plugged continually in areas of heavy trash. A gang extension kit to provide better material flow through the tines is available as an option (although its effectiveness was not evaluated).

Another method of reducing plugging was to use a different sweep pattern. By forming an inverted "V" with the tines (FIGURE 5) trash was pushed to the outside of each gang instead of collecting in the natural funnel formed by the regular pattern. The square tubing, to which the tines were bolted, was removable making the inverted pattern easy to assemble. The inverted tine pattern had no effect on the hilling action but there was a danger of covering the small plants with trash.

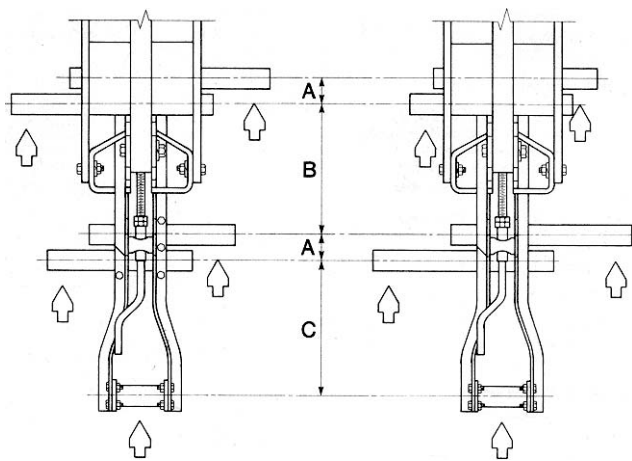

FIGURE 5. Tine configuration: (Left) Regular Pattern, (Right) Inverted Pattern. (A) 2.5 in (64 mm), (B) 13 in (330 mm), (C) 12.5 in (320 mm).

Trash and weed burial was good under most conditions. In heavy trash conditions the dry, lighter stalks were left on top of the soil, while the moist, heavy ones were tilled under.

Field Surface: In normal row crop conditions, the field surface was left quite smooth with a small furrow between the rows and the soils slightly hilled towards the row (FIGURE 6). Rolling shields were used during the first cultivation where crop height was about 2 to 8 in (50 to 200 mm). These provided young plants with good protection except when cultivating at speeds higher than 6 mph (10 km/h).



FIGURE 6. Normal surface left by cultivator.

Furrow Bottom Ridging: Furrow bottom ridging² was apparent wherever the ground was hard packed such as behind the tractor tire or in soils with a hard subsurface layer.

Skewing and Stability: The Massey Ferguson 440 was stable and did not skew excessively under average field conditions. The symmetrical sweep pattern on each gang (FIGURE 5) did not impose any side forces on the cultivator during normal tillage. Some skewing did occur where soil hardness varied across the machine width despite the three-point hitch rigid mounting.

The gangs had a parallel linkage with a wide stance lower link and a narrow upper link. The hinge bolts, through the parallel linkage, had to be tightened regularly to limit the skew of the individual gangs.

Weed Kill: The amount of weed kill depends upon the sweep width and the field speed. In general, a wider sweep will provide better weed kill and more soil movement but less crust and lump shattering than a narrow sweep. High field speeds will provide better weed kill, more soil movement and more crust shattering than low field speeds. Sweeps and field speeds should be matched to field conditions and desired results.

At a field speed of 5 mph (8 km/h) with a 4 in (100 mm) sweep, the weed kill was good under average field conditions.

EASE OF OPERATION AND ADJUSTMENT

Hitching: One person could hitch or unhitch the cultivator in about 5 minutes. Bushings were provided to permit hitching the cultivator to tractors with a Category II or III three-point hitch. As with all rear-mounted implements careful backing of the tractor was required to hitch the cultivator quickly. Care should be taken if more than one person is hitching the cultivator.

Frame Levelling: Levelling of the cultivator was achieved by shortening or lengthening the linkage on the three-point hitch. The two bottom links controlled the lateral levelling while the top link controlled the fore-and-aft levelling. The links were adjusted until all of the sweeps touched the ground at the same time. Some adjustments on the levelness could also be made at the support wheels.

Tillage Depth: Tillage depth was controlled by a gauge wheel at the front of each gang. Raising the gauge wheel lowered the gang thus increasing the tillage depth. The optional crank adjust gauge wheel made depth adjustments fast and accurate. The lower links on the three-point hitch had to be adjusted low enough to allow the cultivator to float at the required tool bar working height.

Maneuverability: Maneuvering the Massey Ferguson 440 was convenient due to the three-point hitch rigid mount. Cultivating with the outer tines of each gang set close to the rows, required extra operator alertness to keep skewing loss to a minimum. The heavy cultivator weight required ballasting of the tractor front end, in order to retain tractor stability.

Transporting: The Massey Ferguson 440 row crop cultivator was easily placed into transport position (FIGURE 7) by one person from the tractor in about two minutes. Transport locking pins were manually inserted to keep the wings folded flat. Caution should be observed when folding or unfolding the wings even though they move at a moderate speed.

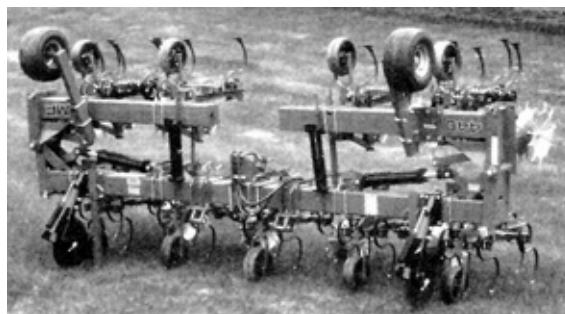

FIGURE 7. Transport position. (Note: Manufacturer recommends lowering the wings prior to unhitching the tractor).

²Ridges left by ground tool in hard surface or subsurface soil.

Transport width of the test machine was 15.3 ft (4.7 m) while transport height was 7.9 ft (2.4 m). Care was required when transporting on public roads, through gates and over bridges.

The Massey Ferguson 440 transported well, without sway, at normal transport speeds. The transport sweep-to-ground clearance of 11 in (280 mm) was adequate on slopes and rough terrain. Care should be taken not to engage the clutch too quickly as the front tractor tires may tend to lift off the ground even when front end ballast is used.

Sweep Installation: The 41 sweeps could be changed by one person in about one hour. The sweep bolts extended beyond the nuts thus exposing the bolt threads to damage by soil abrasion. Sweep-to-ground clearance of 11 in (280 mm) was adequate for easy sweep removal.

Tine Installation: The tines were easily removed or adjusted by loosening one bolt and sliding them along the cross members.

POWER REQUIREMENTS

Draft Characteristics: FIGURE 8 shows draft requirements per row for the Massey Ferguson 440 under average field conditions at a speed of 5 mph (8 km/h) in moist clay loam. It should be noted that variation in soil conditions affect draft much more than variation in machine make, usually making it difficult to measure significant draft differences between different makes of row crop cultivators.

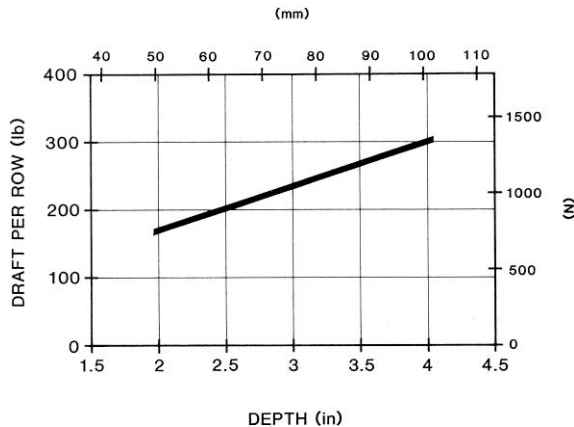

FIGURE 8. Typical draft requirements for Massey Ferguson 440, at 5 mph (8 km/h), under average field conditions.

Increasing speed by 1 mph (1.6 km/h) increased draft by about 25 lb/row (111 N/row). This represents a draft increase of about 200 lb (890 N) for the eight-row test machine.

Actual draft power requirements for the Massey Ferguson 440 at the 4 in (100 mm) depth varied from 39 to 88 hp (29 to 66 kW) for speeds of 4.0 to 7.0 mph (6.4 to 11.3 km/h) respectively.

Tractor Size: Tractor size was dictated by the stability requirements for this eight-row test machine. A tractor (with front ballast) of about 120 hp (89 kW) was suitable.

OPERATOR SAFETY

The low transport height of 7.9 ft (2.4 m), of the test machine, presented no problem with regard to power and telephone lines.

The test machine was 15.3 ft (4.7 m) wide in transport position. This necessitated caution when transporting on public roads, over bridges and through gates. A slow moving vehicle (SMV) sign was not provided by the manufacturer, although a mounting bracket for the SMV sign was supplied.

The test machine could be safely hitched to a tractor by one person. If a second person is used to hitch the cultivator the person on the ground should stand behind the cultivator away from the tractor, for maximum safety.

OPERATOR MANUAL

The operator manual included instruction on set-up, operation, adjustment, maintenance and safety. It was generally very well written and clearly illustrated.

DURABILITY

The Massey Ferguson 440 row crop cultivator was operated for about 131 hours while cultivating about 1220 ac (494 ha). The

intent of this evaluation was a measure of general performance. An extended durability evaluation was not conducted. No mechanical problems occurred during the test.

APPENDIX I

SPECIFICATIONS

MAKE: Massey Ferguson
MODEL: 440, eight-row, 36 inch spacing
SERIAL NUMBER: 2924

DIMENSIONS:	FIELD POSITION	TRANSPORT POSITION
-- width	27.3 ft (8.3 m)	15.3 ft (4.7 m)
-- length (from lower hitch point to rear of cultivator)	4.5 ft (1.4 m)	4.4 ft (1.3 m)
-- height	5.2 ft (1.6 m)	7.9 ft (2.4 m)
-- ground clearance		11 in (280 mm)

TINES:

-- number	41	
-- trash clearance (fmm to sweep tip)	15 in	(390 mm)
-- number of tine rows	5	
-- longitudinal distance between tine rows		
-- first-second	2.5 in	(60 mm)
-- second-third	13 in	(330 mm)
-- third-fourth	2.5 in	(60 mm)
-- fourth-fifth	12.5 in	(320 mm)
-- tine cross section	1-1/4 x 3/8 in	(30 x 10 mm)
-- sweep bolt size	3/8x 1-14 in UNC	

TINE TREES:

-- number of tines per gang	5	
-- weight with shields (five tines)	216 lb	(98 kg)
-- weight without shields	176 lb	(80 kg)
-- gauge wheel adjustment	3.5 in	(90 mm)
-- maximum width of cut per tree	27.5 in	(700 mm)

HITCH AND DEPTH CONTROL:

-- three-point hitch
 -- Category II and III

FmmE:

-- type	180° folding wings
-- tool bar	7 in (180 mm) square tubing, 0.19 in (5 mm) wall
-- tine tree	2 in (51 mm) square tubing, 0.13 in (3 mm) wall

SUPPORT WHEELS:

-- adjustment	12 in	(305 mm)
-- tire	18 x 9.50 8 NHS, 4 ply	

NUMBER OF LUBRICATION POINTS:

58 grease fittings

HYDRAUIC CYLINDERS:

-- wing lift	two, 3.5 x 16 in	(90 x 410 mm)
--------------	------------------	---------------

WEIGHTS:

-- overall without shields	3170 lb	(1440 kg)
-- overall with shields	3350 lb	(1520 kg)

OPTIONAL EQUIPMENT:

-- gang extension kit
 -- crank adjust gang gauge wheels
 -- rolling shields (standard or split)

APPENDIX II

MACHINE RATINGS

The following rating scale is used in Machinery Institute Evaluation Reports:

Excellent	Fair
Very Good	Poor
Good	Unsatisfactory

APPENDIX III

CONVERSION TABLE

Acre (ac) x 0.405	= Hectare (ha)
Foot (ft) x 0.305	= Metre (m)
Inches (in) x 25.4	= Millimetres (mm)
Horsepower (hp) x 0.746	= Kilowatt (kW)
Miles/Hour (mph) x 1.61	= Kilometre/Hour (km/h)
Pounds Force (lb) x 4.45	= Newton (N)
Pounds Force/Foot (lb/ft) x 14.6	= Newton/Metre (N/m)
Pounds Force-Feet (lb-ft) x 1.36	= Newton-Metre (N-m)
Pounds Force/square Inch (psi) x 6.89	= Kilopascal (kPa)
Pounds Mass (lb) x 0.454	= Kilogram (kg)
Tons Mass (ton) x 0.91	= Tonnes (t)

SUMMARY CHART

MASSEY FERGUSON 440 ROW CROP CULTIVATOR

RETAIL PRICE: \$7,771.90

(January 1984, f.o.b. Portage la Prairie, Manitoba) 8-row, 36 inch (900 mm) spacing with rolling shields, support wheels, guide coulters, crank adjust gauge wheels, and 4 in (100 mm) sweeps.

	<u>Evaluation</u>	<u>Comments</u>
QUALITY OF WORK		
Penetration	Good	reduced in hard packed soil
Trash Clearance	Good	some plugging in trashy conditions
Trash Burial	Good	moist, heavy stalks well buried
Field Surface	Very Good	choice of field surfaces dependant on tine configurations
Weed Kill	Good	with 4 inch (100 mm) sweeps at 5 mph (8 km/h) under average conditions
EASE OF OPERATION AND ADJUSTMENT		
Hitching	Very Good	about 5 minutes for Category III
Fmme Levelling	Good	additional adjustment at support & guide wheels
Tillage Depth	Very Good	fast and simple with crank adjust wheels
Maneuverability	Very Good	three-point hitch rigid mount
Transporting	Very Good	large transport width locking pins easily inserted
Sweep Installation	Good	adequate sweep-to-ground clearance sweep bolts extended beyond nuts
Tine Installation	Very Good	adjusted by sliding along cross members
OPERATOR SAFETY	Very Good	large transport width good caution decals
OPERATOR MANUAL	Excellent	very clear, concise and well illustrated
POWER REQUIREMENTS		
	<u>Row</u>	<u>Total</u>
Draft at 5 mph (8km/h)	235 lb (1.0 kN)	1885 lb (8.4 kN)
Draft increase per mph (1.6 km/h)	25 lb (0.1 kN)	200 lb (0.9 kN)
Minimum Overall Tractor Size		120 hp (89 kW)
		in 3 in (75 mm) of moist clay for cultivator stability



**ALBERTA
FARM
MACHINERY
RESEARCH
CENTRE**

3000 College Drive South
Lethbridge, Alberta, Canada T1K 1L6
Telephone: (403) 329-1212
FAX: (403) 329-5562
<http://www.agric.gov.ab.ca/navigation/engineering/afmrc/index.html>

Prairie Agricultural Machinery Institute

Head Office: P.O. Box 1900, Humboldt, Saskatchewan, Canada S0K 2A0
Telephone: (306) 682-2555

Test Stations:	P.O. Box 1150
P.O. Box 1060	Humboldt, Saskatchewan, Canada S0K 2A0
Portage la Prairie, Manitoba, Canada R1N 3C5	Telephone: (306) 682-5033
Telephone: (204) 239-5445	Fax: (306) 682-5080
Fax: (204) 239-7124	