

Evaluation Report 228



John Deere 1610 (10.2 m) Chisel Plow

A Co-operative Program Between



JOHN DEERE 1610 CHISEL PLOW

MANUFACTURER:

John Deere Des Moines Works
Des Moines, Iowa 50306
U.S.A.

DISTRIBUTOR:

John Deere Limited
455 Park Street
Regina, Saskatchewan
S4P 3L8

SUMMARY AND CONCLUSIONS

The overall functional performance of the John Deere 1610 heavy duty cultivator was good. Performance was reduced by uneven wing section penetration in hard soil.

The spring cushioned shanks could lift 210 mm (8 in) to clear stones. When equipped with 50 degrees sweeps, sweep pitch varied from 2 to 5 degrees over the normal draft range for heavy duty cultivators. With 305 mm (12 in) spacing, shank spring preload was exceeded at a draft of 7.3 kN/m (500 lbs/ft), slightly above the normal primary tillage draft range.

Penetration was uniform in secondary tillage and light primary tillage. In heavy primary tillage, the wing section ends penetrated about 25 mm (1 in) deeper than the centre section. Wing frame twist was negligible in all field conditions. Furrow bottom ridging was about 25 mm (1 in) in heavy primary tillage.

The John Deere 1610 effectively followed the contour of rolling land. Weed kill was very good in most conditions. The John Deere 1610 was quite stable. Weed misses due to skewing occurred only on steep hills. Trash clearance was excellent. The optional mounted harrows did not effectively clear heavy trash. The harrows were not aggressive enough to uproot and expose weeds in tough soil conditions.

The John Deere 1610 could be easily placed in transport position in less than five minutes. The 200 mm (8 in) sweep-to-ground clearance and 3 m (9.8 ft) transport wheel tread were adequate. The John Deere 1610 towed well without sway, at the manufacturer's recommended 16 km/h (10 mph) transport speed.

The 10.2 m (33 ft) test machine had a transport height of 4.1 m (12.5 ft), permitting safe movement under power lines in the three prairie provinces. Transport heights of some wider models of this cultivator are greater than minimum power line heights.

The rigid hitch link made one-man hitching easy. The hitch jack was too short to support the hitch without additional blocking. Adequate adjustment was provided for both lateral and fore-aft frame levelling.

Average draft for the 10.2 m (33 ft) wide test machine in light primary tillage at 8 km/h (5 mph) varied from 16.4 kN (3681 lb) at 50 mm (2 in) depth to 36.5 kN (8208 lb) at 125 mm (5 in) depth. In heavy primary tillage at 8 km/h (5 mph) average draft varied from 19.5 kN (4390 lb) at 50 mm (2 in) depth to 66 kN (14,820 lb) at 125 mm (5 in) depth.

In light primary tillage at 10 km/h (6 mph) and 75 mm (3 in) depth, a tractor with 120 kW (155 hp) maximum power take-off rating will have sufficient power reserve to operate the 10.2 m (33 ft) wide John Deere 1610. In heavy primary tillage at the same depth and speed, a 153 kW (200 hp) tractor is needed.

The John Deere 1610 was equipped with mechanical wing transport locks and a hydraulic depth control lock for safe towing. A slow moving vehicle sign was provided. The operator's manual was concise and well illustrated.

A few mechanical problems occurred during the 156 hours of field operation. Two shanks bent. The harrow spring mounts bent, and one harrow mounting bolt broke.

RETAIL PRICE

\$17,426.73 (May, 1981, f.o.b. Humboldt, 10.2 m width, with optional tandem wing wheels and optional John Deere finishing harrows).

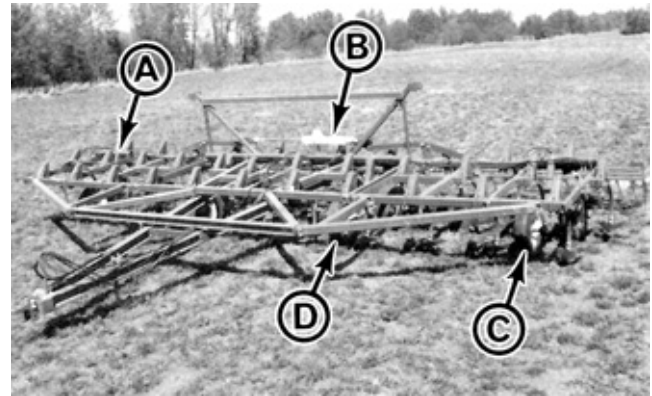

FIGURE 1. John Deere 1610: (A) Depth Control Cylinders, (B) Wing Lift Cylinder, (C) Tandem Wing Wheels, (D) Tandem Centre Wheels.

RECOMMENDATIONS

It is recommended that the manufacturer consider:

1. Modifying the mounted harrows to provide tine angle and harrow pressure adjustment to improve trash clearance and spreading.
2. Supplying a longer hitch jack.
3. Modifying the harrow spring mounts to reduce bending.
4. Working with the agricultural equipment industry to standardize hydraulic quick couplers and hydraulic hose fitting threads.
5. Working with the agricultural equipment industry to standardize shank and sweep stem angles, and sweep fastener spacings and sizes.

Chief Engineer -- E. O. Nyborg

Senior Engineer -- J. D. MacAulay

Project Technologist -- A. R. Boyden

THE MANUFACTURER STATES THAT

With regard to recommendation number:

1. The mounted harrow attachment we provide for use with the chisel plow is designed for seedbed preparation, including working in surface trash conditions. Where heavy trash conditions exist, the need and effectiveness of a harrow attachment is reduced.
2. A new longer hitch jack has been adopted for 1982 machines.
3. The bending described in the report appears to result from hitting an object in the field.
4. Deere & Company is evaluating the new ISO quick couplers for future application.
5. The sweep stem angles meet ASAE standards. Deere & Company is represented on the standardization Committees of ASAE including the committee that deals with standards on shanks and sweep stem angles.

NOTE: This report has been prepared using SI units of measurement. A conversion table is given in APPENDIX III.

GENERAL DESCRIPTION

The John Deere 1610 is a trailing, flexible, three-section heavy duty cultivator suitable for medium and heavy primary tillage operations. It is available in 10 widths ranging from 7 to 12.5 m (23 to 41 ft). The test machine was a 10.2 m (33 ft) model, with a 4 m (13 ft) centre frame and two 3.1 m (10 ft) wings. It was equipped with 33 spring cushioned shanks, laterally spaced at 305 mm (12 in), and arranged in three rows.

The centre frame is carried on two tandem wheel sets, while each wing is supported by one tandem wheel set. Three hydraulic cylinders, connected in series, control tillage depth. The wings folded into transport position with one hydraulic cylinder. A tractor with dual remote hydraulic controls is needed to operate the John Deere 1610.

Detailed specifications are given in APPENDIX I while FIGURE 1 shows the location of major components.

SCOPE OF TEST

The John Deere 1610 was operated in the field conditions shown in TABLE 1 for 156 hours, while cultivating about 1200 ha (2960 ac). It was evaluated for quality of work, ease of operation and adjustment, power requirements, safety, and suitability of the operator's manual.

Optional attached finishing harrows were used during the test.

TABLE 1. Operating Conditions.

| FIELD CONDITION | HOURS | FIELD AREA (ha) |
|---------------------|-------|-----------------|
| Soil Type | | |
| — light loam | 22 | 154 |
| — loam | 59 | 452 |
| — clay | 75 | 594 |
| TOTAL | 156 | 1 200 |
| Stony Phase | | |
| — stone free | 97 | 756 |
| — occasional stones | 21 | 156 |
| — moderately stony | 15 | 125 |
| — very stony | 23 | 163 |
| TOTAL | 156 | 1 200 |

RESULTS AND DISCUSSION

QUALITY OF WORK

Shank Characteristics: There is a large variation in shank and sweep stem angles (FIGURE 2) on cultivators from different manufacturers. Sweeps and shanks must be matched to obtain sufficient sweep pitch to achieve and maintain penetration. Usually manufacturers recommend sweeps with a stem angle from 0 to 5 degrees less than the shank stem angle to result in a slightly positive no-load sweep pitch.

Sweep pitch increases in proportion to draft due to shank flexing and, depending on shank stiffness and cushioning spring preload, may become excessive on some cultivators in normal tillage. A slightly positive sweep pitch results in uniform tillage depth and a smooth furrow bottom while excessive sweep pitch causes furrow bottom ridging, and rapid sweep tip wear. Shanks which maintain a relatively constant sweep pitch, over the normal range of tillage forces, are desirable.

The John Deere 1610 was equipped with spring cushioned shank holders. Spring preload was not adjustable. During the test, 406 mm (16 in) wide John Deere sweeps with a 50 degree stem angle were used giving a no load sweep pitch of 2 degrees.

FIGURE 3 shows pitch characteristics of the John Deere shank assembly. The low end of the pitch curve results from shank flexing while the steeper part is due to cushioning spring deflection. Sweep pitch varied 3 degrees over the full draft range normally occurring in primary tillage. When equipped with 50 degree sweeps, sweep pitch varied from 2 to 5 degrees over this range. Cushioning spring preload was exceeded at drafts greater

than 7.3 kN/m (500 lb/ft). This occurred at the upper end of the primary tillage draft range, indicating the John Deere 1610 was suited for most primary tillage.

FIGURE 4 shows the lifting pattern when shanks encounter stones or field obstructions. Maximum lift height was 210 mm (8 in). Two shanks and two sweeps bent during the 156 hour test period. (See DURABILITY RESULTS).

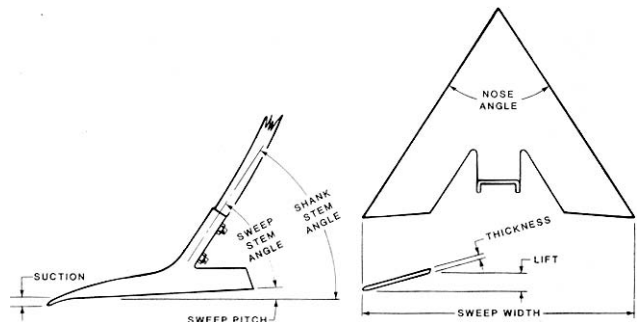

FIGURE 2. Shank and Sweep Terminology.

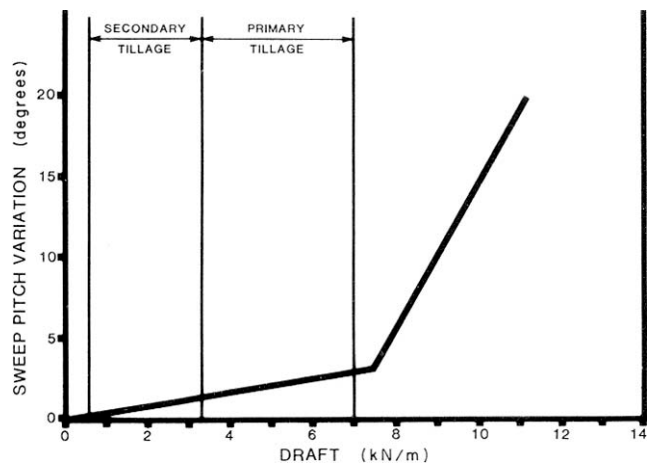

FIGURE 3. Sweep Pitch Variation over a Normal Draft Range (305 mm spacing).

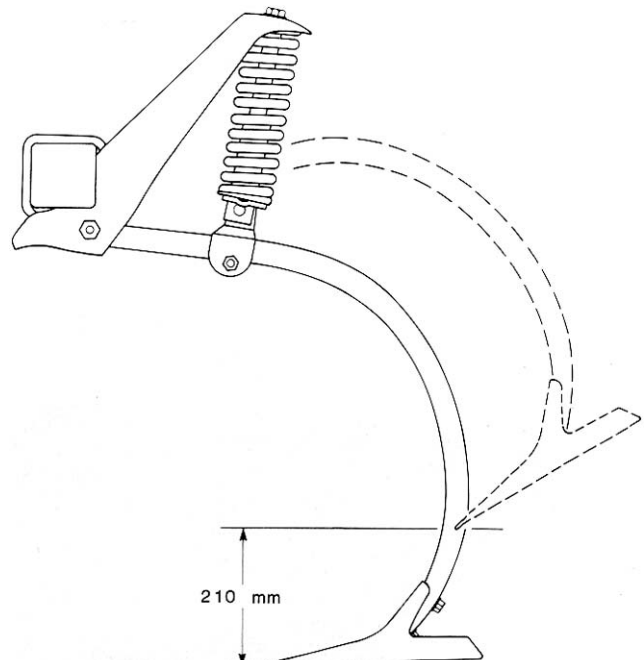

FIGURE 4. Shank Lifting Pattern.

Penetration: The cultivator mass of 338 kg/m (227 lb/ft) was sufficient for adequate penetration in all conditions. Penetration was uniform in secondary tillage and light primary tillage. In heavy primary tillage at a 75 mm (3 in) tillage depth, the outer ends of the wings penetrated about 25 mm (1 in) deeper than the centre section. The non-uniformity increased at greater tillage depths, (FIGURE 5). In very heavy tillage, wing end sweep pitch became excessive resulting in instability. The manufacturer recommends the use of spikes in such conditions.

Depth differences between the front and rear rows of shanks were slight in normal soil conditions, once the frame had been properly levelled. In heavy primary tillage, the outer rear sweeps penetrated about 25 mm (1 in) deeper than the outer front sweeps due to cushioning spring preload being exceeded on the front shanks.

The John Deere 1610 followed gently rolling field contours very well. The similar widths of the centre and wing sections resulted in fairly uniform penetration across the cultivator width, in rolling fields. As with most wing cultivators, large variations in tillage depth occurred in fields with abrupt contour changes.

Plugging: Trash clearance was excellent. Occasional plugging occurred at the wheel locations in excessive trash conditions. The mounted harrows did not effectively clear heavy trash.

Trash Burial and Field Surface: When using 50 degree sweeps at 75 mm (3 in) tillage depth, at speeds below 6 km/h (4 mph) most stubble was left standing upright. The amount of trash burial increased appreciably with increased speed. In normal conditions, enough trash was buried in first operation summer-fallow to permit the use of a field cultivator for subsequent tillage.

Trash burial with chisel points was good (FIGURE 6). The chisel points moved enough soil for adequate trash burial while leaving some standing stubble for snow retention.

In light trash, the optional finishing harrows distributed trash evenly. In normal to heavy trash in first operation summerfallow, the harrows left trash bunches on the field surface (FIGURE 7). The harrow tine angle and bar pressure were not adjustable, and the tine spacing was quite narrow. It is recommended that the manufacturer consider modifications to provide tine angle and harrow bar pressure adjustment, and improved trash clearance and distribution characteristics.

Furrow Bottom Ridging: In heavy primary tillage furrow bottom ridging was about 25 mm (1 in).

Skewing and Stability: The John Deere 1610 was stable and did not skew sideways in normal field conditions. The sweep pattern (FIGURE 8) was symmetrical and did not impose any side forces on the cultivator during normal tillage. Slight skewing

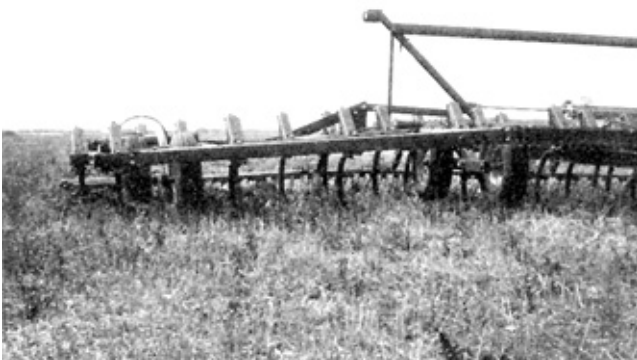

FIGURE 5. Excessive Wing End Penetration in Heavy Primary Tillage.

occurred in varying soil conditions, on hillsides, or when only one wing penetrated deeper than the centre section. When equipped with 406 mm (16 in) sweeps, the cultivator had to skew more than 3 degrees to miss weeds. Weed misses occurred only on steep hillsides.

Weed Kill: Weed kill was very good in normal soil conditions when the cultivator was equipped with 406 mm (16 in) sweeps spaced at 305 mm (12 in). Sweeps were located behind the depth control wheels to uproot weeds in the wheel tracks. In loam and light loam soils, the mounted harrows effectively uprooted and exposed weeds loosened by the cultivator. In clay soils, the mounted harrows usually were not aggressive enough to uproot and expose weeds.

EASE OF OPERATION AND ADJUSTMENT

Transporting: The John Deere 1610 was easily placed in transport position (FIGURE 9) using the hydraulic wing lift system. Mechanical transport locks were provided for the wings while a hydraulic transport lock was provided for the centre section depth control cylinder. The stop valve actuator on the cylinder shaft, which also served as a depth control stop, had to be repositioned to lock the depth control cylinder in fully extended position (FIGURE 10). One man could place the John Deere 1610 in transport position in about five minutes.

Transport width was 6.2 m (18.9 ft) while transport height was 4.1 m (12.5 ft). Care was needed when transporting on public roads, through gates, and over bridges.

The John Deere 1610 towed well without sway at speeds up to 32 km/h (20 mph). The manufacturer recommends that transport speeds be limited to 16 km/h (10 mph). Sweep to ground clearance of 200 mm (8 in) and a wheel tread of 3 m (9.8 ft) gave good transport ground clearance.



FIGURE 6. Typical Trash Burial with Chisel Points.



FIGURE 7. Typical Field Surface When Using Optional Mounted Harrows.

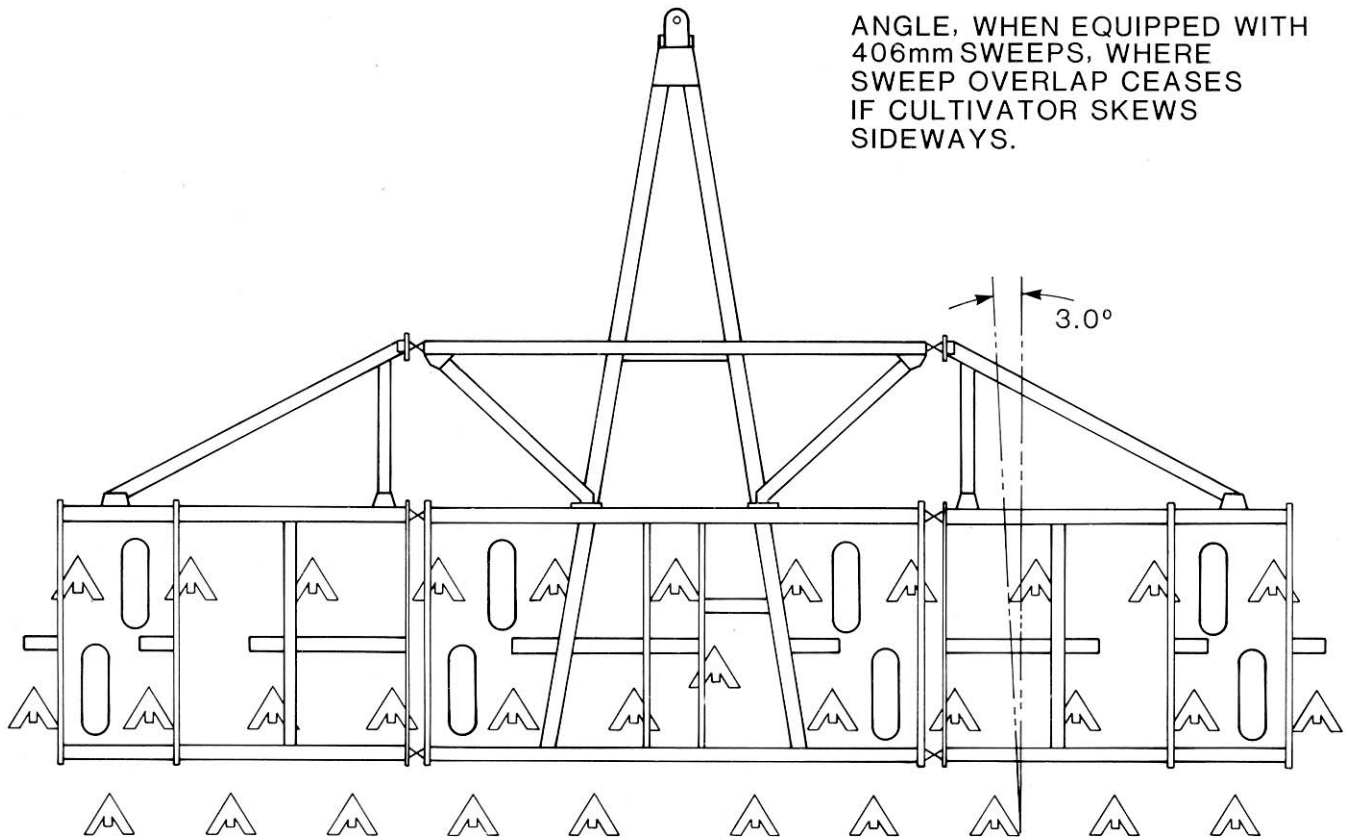

FIGURE 8. Sweep Pattern (305 mm Shank Spacing).

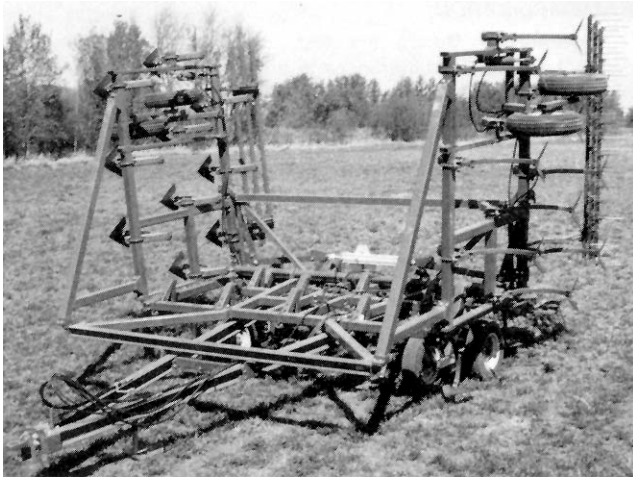

FIGURE 9. Transport Position.



FIGURE 10. Hydraulic Depth Control Stop and Transport Lock.

Hitching: The hitch jack and rigid hitch link made one man hitching easy. The hitch jack was too short to raise the hitch to the proper height, without additional blocking. It is recommended that the manufacturer consider supplying a longer hitch jack. The hitch weight was positive both with and without the mounted harrows.

Hitch height could be adjusted over a range of 200 mm (8 in) in 6 increments by removing two bolts. This range permitted frame levelling with all tractors used during the test.

Maneuverability: The hitch pole was narrow, permitting normal turns without tractor wheel interference. The centre section tandem wheels skidded on sharp turns.

Frame levelling: Adjustable wing cylinder eye-bolts provided adequate lateral frame levelling.

Depth of Tillage: Tillage depth was controlled with three hydraulic cylinders connected in series. A hydraulic stop valve on the centre section (FIGURE 10) cylinder could be adjusted to set tillage depth. As is common with series hydraulic systems, to maintain the centre and wing frames at the same depth, periodic synchronization of the cylinders, by completely extending them to fully raised position, was necessary.

Sweep Installation: It took one man about one and one-half hours to change the 33 sweeps on the John Deere 1610. The sweep bolts were of proper length so that all threads were covered by the retaining nuts. The 200 mm (8 in) sweep to ground clearance was adequate for easy sweep removal.

Shank Installation: Individual shanks could be easily replaced in less than 10 minutes by removing two bolts.

POWER REQUIREMENTS

Draft Characteristics: FIGURE 11 shows draft requirements for heavy duty cultivators in typical primary tillage, at a speed of 8 km/h (5 mph). This figure gives average requirements based on tests of 14 makes of heavy duty cultivators in 53 different field conditions. Attempting to compare draft requirements of different makes of heavy duty cultivators usually is unrealistic. Draft requirements for the same cultivator, in the same field, may vary by as much as 30% in two different years, due to changes in soil

conditions. Variation in soil conditions affect draft much more than variation in machine make, usually making it impossible to measure any significant draft differences between different makes of heavy duty cultivators.

In light primary tillage, average specific draft at 8 km/h (5 mph), varied from 1.6 kN/m (110 lb/ft) at 50 mm (2 in) depth to 3.6 kN/m (246 lb/ft) at 125 mm (5 in) depth. For the 10.2 m (33 ft) John Deere 1610, this corresponds to a total draft ranging from 16.4 to 36.5 kN (3681 lb to 8208 lb).

In heavy primary tillage, average specific draft at 8 km/h (5 mph) varied from 1.9 kN/m (132 lb/ft) at 50 mm (2 in) to 6.5 kN/m (444 lb/ft) at 125 mm (5 in) depth, corresponding to a total draft from 19.5 to 66 kN (4390 to 14,820 lb) for the 10.2 m (33 ft) test machine.

Increasing speed by 1 km/h (0.6 mph) increased draft by about 95 N/m (6.5 lb/ft). For the 10.2 m (33 ft) test machine this represents a draft increase of 1 kN (225 lb) for a 1 km/h (0.6 mph) speed increase.

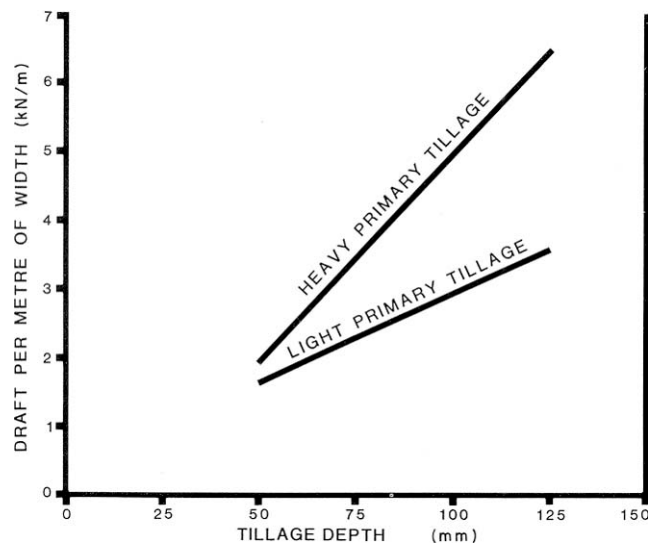

FIGURE 11. Average Draft Requirements for Heavy Duty Cultivators at 8 km/h.

Tractor Size: TABLES 2 and 3 show tractor sizes needed to operate the 10.2 m (33 ft) wide John Deere 1610 in light and heavy primary tillage. Tractor sizes have been adjusted to include tractive efficiency and represent a tractor operating at 80% of maximum power on a level field. The sizes presented in the tables are the maximum power take-off rating, as determined by Nebraska tests or as presented by the tractor manufacturer. Selected tractor sizes will have ample power reserve to operate the John Deere 1610 in the stated conditions.

Tractor size may be determined by selecting the desired tillage depth and speed from the appropriate table. For example, in light primary tillage at 75 mm (3 in) depth and 10 km/h (6 mph), a 120 kW (155 hp) tractor is needed to operate the John Deere 1610. In heavy primary tillage, at the same depth and speed, a 153 kW (200 hp) tractor is needed.

OPERATOR SAFETY

Extreme caution is needed in transporting most folding cultivators to avoid contacting power lines. Minimum power line heights vary in the three prairie provinces. In Saskatchewan, the energized line may be as low as 5.2 m (17 ft) over farm land or over secondary roads. In Alberta and Manitoba, the neutral ground wire may be as low as 4.8 m (15.7 ft) over farm land. In all three provinces, lines in farm yards may be as low as 4.6 m (15 ft).

Transport height of the 10.2 m (33 ft) test machine was 4.1 m (13.5 ft), permitting safe transport under prairie power lines. However, several wider models have transport heights too high for many prairie power lines. The legal responsibility for safe passage under utility lines rests with the machine operator and not with the power utility or the machinery manufacturer. All provinces have regulations governing maximum permissible equipment heights on

TABLE 2. Tractor Size (Maximum Power Take-Off Rating, kW) to Operate the 10.2 m John Deere 1610 in Light Primary Tillage.

| DEPTH (mm) | SPEED (km/h) | | | | | |
|------------|--------------|-----|-----|-----|-----|-----|
| | 7 | 8 | 9 | 10 | 11 | 12 |
| 50 | 52 | 53 | 75 | 87 | 101 | 116 |
| 75 | 74 | 89 | 104 | 120 | 137 | 154 |
| 100 | 97 | 114 | 133 | 152 | 172 | 193 |
| 125 | 120 | 140 | 162 | 184 | 208 | 232 |

TABLE 3. Tractor Size (Maximum Power Take-Off Rating, kW) to Operate the 10.2 m John Deere 1610 in Heavy Primary Tillage.

| DEPTH (mm) | SPEED (km/h) | | | | | |
|------------|--------------|-----|-----|-----|-----|-----|
| | 7 | 8 | 9 | 10 | 11 | 12 |
| 50 | 54 | 65 | 77 | 89 | 103 | 118 |
| 75 | 98 | 116 | 134 | 153 | 178 | 194 |
| 100 | 143 | 167 | 191 | 217 | 243 | 270 |
| 125 | 188 | 218 | 249 | 281 | 313 | 347 |

various types of public roads. If height limits are exceeded, the operator must contact power and telephone utilities before moving.

The test machine was 6.2 m (20.3 ft) wide in transport position, necessitating caution when transporting.

Mechanical wing transport locks were provided. The centre section depth control cylinder could be hydraulically locked in transport position by using the adjustable depth control stop on the cylinder shaft. The cultivator should be blocked, when working under it, as a precautionary safety measure.

A slow moving vehicle sign was supplied with the cultivator as standard equipment.

The tires on the centre frame were adequately sized to support the cultivator in transport position, with mounted harrows, up to the manufacturer's recommended transport speed of 16 km/h (10 mph).

STANDARDIZATION

Hydraulics: During the test, considerable difficulty was encountered due to differences in hydraulic couplers on various tractors. The difficulty was in the lack of standardization both in couplers and in hose threads. More standardization is needed in this area.

Sweep Bolt Holes: The bolt hole size and spacing on cultivator sweeps and shanks, as well as stem angles, should similarly be standardized to provide some degree of interchangeability of sweeps.

OPERATOR'S MANUAL

The operator's manual supplied information on set up, operation, maintenance, trouble shooting, and safety. It was well written and clearly illustrated.

DURABILITY RESULTS

TABLE 4 outlines the mechanical history of the John Deere 1610 during 156 hours of field operation while tilling about 1200 ha (2960 ac). The intent of the test was evaluation of functional performance. An extended durability evaluation was not conducted.

TABLE 4. Mechanical History

| ITEM | OPERATING HOURS | EQUIVALENT FIELD AREA (ha) |
|---|-----------------|----------------------------|
| Wheels | | |
| Two tandem pivot bearing caps were lost and replaced at | 15 | 95 |
| Shank and Holder | | |
| All shank holder U-bolts were tightened at | 15 | 95 |
| All shank pivot bolts were tightened at | 91 | 693 |
| One shank bent and was replaced at | 117, 129 | 917, 1003 |
| Two sweeps bent and were replaced at | 129 | 1003 |
| Mounted Harrows | | |
| The seven harrow spring mounts bent at | 9 | 65 |
| One harrow mounting bolt broke and was replaced at | 101 | 782 |

DISCUSSION OF MECHANICAL HISTORY

WHEELS

The two tandem pivot bearing caps were lost while working in severe rocky conditions.

SHANK AND HOLDER

Shanks and Sweeps: Two shanks and two sweeps bent during testing. These failures do not represent a serious problem.

MOUNTED HARROWS

Harrow Spring Mounts: The harrow spring mounts bent (FIGURE 12) in stony fields, causing reduced spring tension, and preventing the harrows from returning to their lowest horizontal position. It is recommended that the harrow spring mounts be modified to reduce bending.



FIGURE 12. Bent Harrow Spring Mount.

APPENDIX I

SPECIFICATIONS

MAKE: John Deere Chisel Plow
MODEL: 1610 (10.2 m size)
SERIAL NUMBER: 005237
MANUFACTURER: John Deere Des Moines Works
 Des Moines, Iowa 50306
 U.S.A.

| DIMENSIONS: | FIELD POSITION | TRANSPORT POSITION |
|--|-------------------------------------|---------------------------|
| | POSITION | POSITION |
| width | 10,170 mm | 6200 mm |
| length - with harrows | 7170 mm | 7170 mm |
| height | 2210 mm | 4050 mm |
| maximum ground clearance | 200 mm | 200 mm |
| wheel tread | 8400 mm | 3950 mm |
| SHANKS: | | |
| number | 33 | |
| lateral spacing | 305 mm | |
| trash clearance (frame to sweep tip) | 735 mm | |
| number of shank rows | | |
| centre section | 3 | |
| wings | 3 | |
| distance between rows | 990 mm | |
| | 840 mm | |
| shank cross section | 32 x 50 mm | |
| shank stem angle | 52° | |
| sweep hole spacing | 57 mm | |
| sweep bolt size | 1/2 x 2 in | |
| HITCH | | |
| vertical adjustment range | 200 mm | |
| DEPTH CONTROL: | | |
| | hydraulic | |
| FRAME: | | |
| | 100 mm square tubing, 6.4 mm thick | |
| TIRES: | | |
| centre section | 4, 7.60L x 1 5, 6 ply | |
| wings | 4, 7.60L x 15, 6 ply | |
| NUMBER OF LUBRICATION POINTS: | | |
| | 7 grease fittings, 10 hour service | |
| | 12 bearings, 250 hour service | |
| HYDRAULIC CYLINDERS: | | |
| depth control | | |
| centre section | 1, 108 x 203 mm | |
| wings | 1, 102 x 203 mm | |
| | 1, 95 x 203 mm | |
| wing lift | 1, 102 x 813 mm | |
| WEIGHTS: (Without Harrows) | | |
| | FIELD POSITION | TRANSPORT POSITION |
| right wheels | 486 kg | |
| right centre wheels | 1020 kg | 1540 kg |
| left centre wheels | 1018 kg | 1530 kg |
| left wheels | 526 kg | |
| hitch | 390 kg | 406 kg |
| TOTAL | 3440 kg | 3440 kg |
| WEIGHTS: (With Mounted Harrows) | | |
| | FIELD POSITION | TRANSPORT POSITION |
| right wheels | 600 kg | |
| right centre wheels | 1156 kg | 1754 kg |
| left centre wheels | 1194 kg | 1790 kg |
| left wheels | 588 kg | |
| hitch | 288 kg | 288 kg |
| TOTAL | 3826 kg | 3826 kg |
| OPTIONAL EQUIPMENT: | | |
| | 10 width options from 7 m to 12.5 m | |
| | low pressure hydraulic system | |
| | mounted finishing harrows | |
| | hitch jack | |

APPENDIX II

MACHINE RATINGS

The following rating scale is used in PAMI Evaluation Reports:

- | | |
|---------------|--------------------|
| (a) excellent | (d) fair |
| (b) very good | (e) poor |
| (c) good | (f) unsatisfactory |

APPENDIX III

CONVERSION TABLE

| | |
|---------------------------|--------------------------------------|
| 1 hectare (ha) | = 2.5 acre (ac) |
| 1 kilometre/hour (km/h) | = 0.6 miles/hour (mph) |
| 1 millimetre (mm) | = 0.04 inches (in) |
| 1 metre (m) | = 3.3 feet (ft) |
| 1 kilowatt (kW) | = 1.3 horsepower (hp) |
| 1 kilogram (kg) | = 2.2 pounds mass (lb) |
| 1 kilonewton (kN) | = 220 pounds force (lb) |
| 1 kilonewton/metre (kN/m) | = 70 pounds force/foot (lb/ft) |
| 1 kilopascal (kPa) | = 0.2 pounds force/square inch (psi) |



**ALBERTA
FARM
MACHINERY
RESEARCH
CENTRE**

3000 College Drive South
Lethbridge, Alberta, Canada T1K 1L6
Telephone: (403) 329-1212
FAX: (403) 329-5562

<http://www.agric.gov.ab.ca/navigation/engineering/afmrc/index.html>

Prairie Agricultural Machinery Institute

Head Office: P.O. Box 1900, Humboldt, Saskatchewan, Canada S0K 2A0
Telephone: (306) 682-2555

Test Stations:

P.O. Box 1060

Portage la Prairie, Manitoba, Canada R1N 3C5

Telephone: (204) 239-5445

Fax: (204) 239-7124

P.O. Box 1150

Humboldt, Saskatchewan, Canada S0K 2A0

Telephone: (306) 682-5033

Fax: (306) 682-5080