

Printed: November 1988
Tested at: Lethbridge
ISSN 0383-3445
Group 10 (d)

Evaluation Report

550

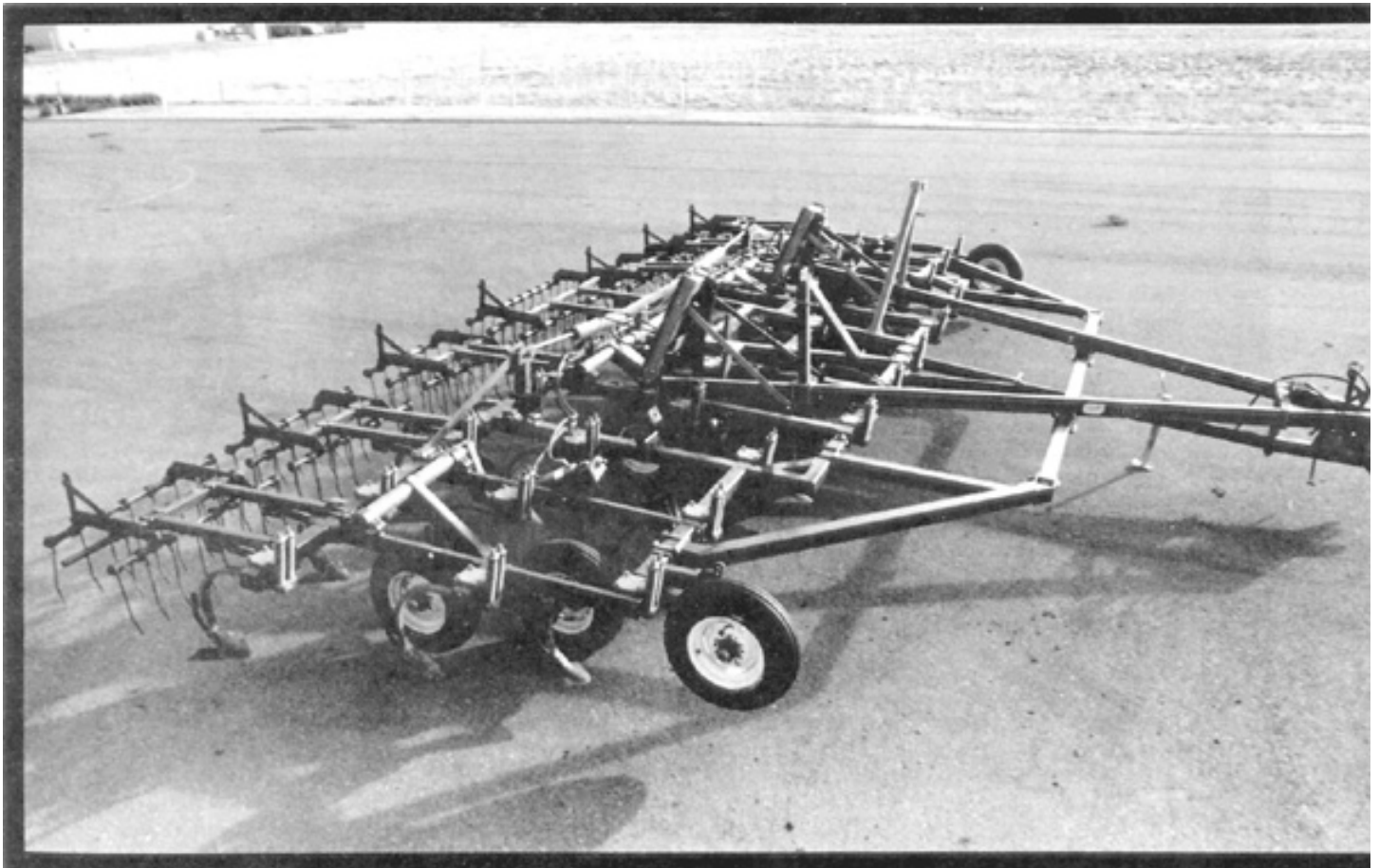

Cereal Implements Model 807 Chisel Plow

A Co-operative Program Between



CEREAL IMPLEMENTS MODEL 807 CHISEL PLOW

MANUFACTURER:

Vicon Western Canada
1000 Sixth Avenue N E
Portage la Prairie, Manitoba
R1N 3R3
Phone: (204) 239-5544

DISTRIBUTOR:

Cereal Implements
P.O. Box 3200
Portage la Prairie, Manitoba
R1N 3R3

RETAIL PRICE:

\$22,526.00 (March, 1988, f.o.b. Lethbridge, Alberta)

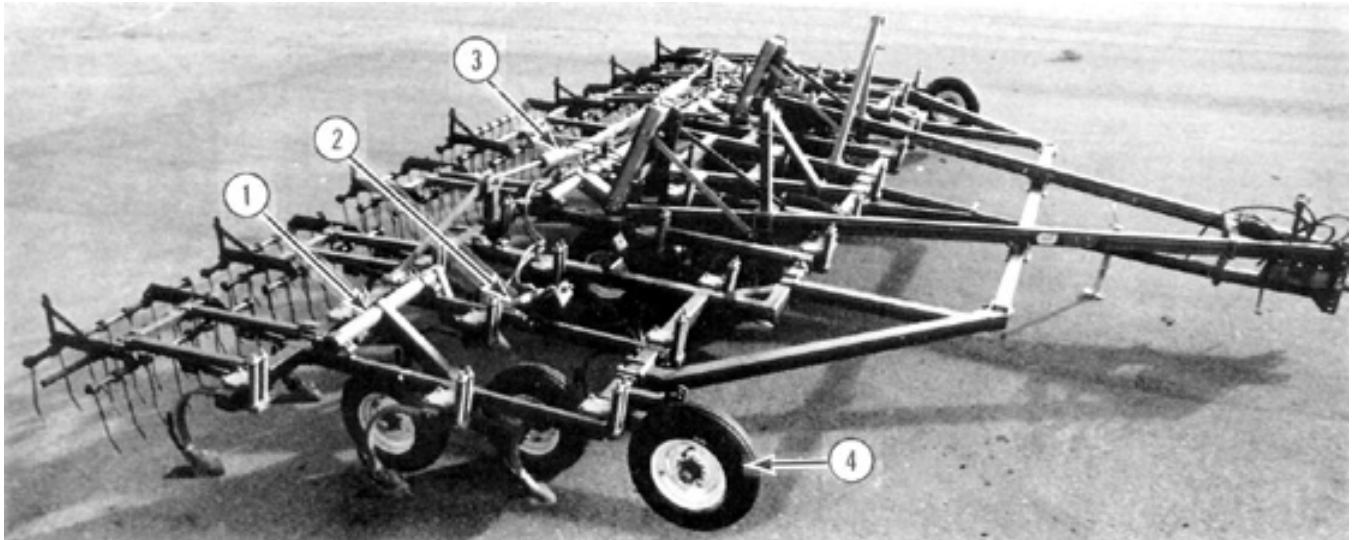

FIGURE 1. Cereal Implements Model 807 Chisel Plow: (1) Rock Shaft, (2) Depth Control Cylinder, (3) Wing Lift Cylinder (4) Stabilizer Wheel.

SUMMARY

Quality of Work: The Cereal Implements Model 807 heavy duty chisel plow was suitable for primary and secondary tillage. Penetration was very good with the 16 in (406 mm) sweeps at 12 in (305 mm) shank spacing. Depth uniformity was very good. Laboratory testing of the Model 807 shank assembly showed it would maintain a uniform tillage or seeding depth while operating in primary and secondary tillage. The cultivator shank configuration allowed for overlap without running the wheel on cultivated soil.

The maximum lift height of the shank assembly was 5 in (127 mm) when equipped with 16 in (406 mm) McKay sweeps. This lift height provided only fair stone protection.

Trash clearance at the 12 in (305 mm) shank spacing was very good. In heavy, clamp trash, plugging would occur at the wheel locations. With the optional harrows attached, the surface finish left by the CI 807 in light, loose trash was good. The harrows were not used in heavy trash conditions.

The Model 807 was stable but did skew in gently to moderately rolling field conditions. Weed kill was good with the 16 in (406 mm) sweeps at 12 in (305 mm) shank spacing.

Ease of Operation and Adjustment: Transporting the Model 807 chisel plow was very good. The hitch jack and

rigid hitch link made one man hitching easy. If the optional harrows were attached, care had to be taken when disconnecting the chisel plow from the tractor, because of its negative hitch weight.

Ease of levelling the frame was very good. Vertical hitch adjustment was 14 in (356 mm) in six increments. The wing wheels could be adjusted separately for lateral levelling. Ease of setting the tillage depth was very good. A stop on the left center frame cylinder was adjusted to set the tillage depth.

Ease of setting the harrows was poor. Considerable time was required to adjust the height and pressure of the optional harrows.

Power Requirements: In secondary tillage at 3 in (75 mm) and 5 mph (8 km/h), a tractor with 151 (112 kW) PTO horsepower is required. At the same speed and depth in primary tillage a 203 (152 kW) PTO horsepower is required.

Operator Safety: Operation of the Model 807 chisel plow was good provided normal safety procedures were provided.

Operator's Manual: The operator's manual was very good, containing useful information on safety, assembly, adjustment, specifications, maintenance and operation. A detailed parts list was also included.

Mechanical History: Three bent shanks, five broken sweeps and twenty expansion pins were replaced.

RECOMMENDATIONS

It is recommended that the manufacturer consider:

1. Modifying the shank assembly to reduce shank damage when operating in rocky conditions.
2. Balancing the cultivator (when optional harrows are attached) so that an operator can safely hitch and unhitch the unit from his tractor.
3. Modifying the height and pressure adjustment on the tine harrows to improve the setting time.
4. Supplying a safety chain as standard equipment in accordance with ASAE standards.

Station Manager: R. P. Atkins

Project Technologist: G. A. Magyar

THE MANUFACTURER STATES THAT

With recommendation number:

1. The Company is presently taking steps to improve the strength of the shank, improve the trip height and also increase the trip force.
2. The balance of the chisel plow is neutral when equipped with C.I. tine harrows (which are of heavier construction than most). In subsequent operators manuals, the procedure for hitching and unhitching will be highlighted. The recommended procedure will be to have the weight of the machine resting upon the shovels prior to hitching or unhitching.
3. Modifications to the tine harrow adjustments are not planned at this time. Our present design has proven to be rugged and reliable and requires a minimum of adjustment.
4. The available safety chain and its use is described in both parts and operators manuals. It will be included as standard equipment in subsequent production.

GENERAL DESCRIPTION

The Cereal Implements Model 807 Chisel Plow is a trailing, three section chisel plow suitable for primary and secondary tillage operations. The test machine is 35 ft (10.7 m) wide with a 13.8 ft (4.2 m) center frame and two 10.8 ft (3.3 m) wing sections. It has 35 spring cushion shanks arranged in four rows and spaced at 12 in (305 mm) intervals.

The center frame is supported by two tandem walking beam wheel sets, while each wing frame is supported by one tandem wheel set and one stabilizer wheel. Four hydraulic cylinders connected in series control tillage depth. The wings fold into transport position with two hydraulic cylinders connected in parallel. A tractor with dual remote hydraulic controls is needed to operate the Model 807 chisel plow. The test machine was equipped with optional three row tine harrows.

The Model 807 chisel plow is available in widths from 25 ft (7.6 m) to 41 ft (12.5 m).

Detailed specifications are given in APPENDIX 1 while FIGURE 1 shows the location of major components.

SCOPE OF TEST

The Model 807 was tested during seeding in conjunction with Cereal Implements Model 1203 Air Seeder (Evaluation Report #541) and tillage operations in field conditions shown in TABLE 1, for approximately 164 hours while cultivating about 3080 ac (1247 ha). It was evaluated for quality of work, ease of operation and adjustment, power requirements, safety and suitability of the operator's manual.

TABLE 1. Operating Conditions

FIELD CONDITIONS	HOURS	FIELD AREA	
		ac	(ha)
Operation:			
- Primary	328.7	520	(211)
- Secondary	135.3	2560	(1036)
TOTAL	164.0	3080	(1247)
Soil Type:			
- Sandy Loam	8.0	160	(65)
- Silt Loam	16.2	320	(130)
- Silty Clay Loam	62.5	1100	(445)
- Clay Loam	24.0	480	(194)
- Loam	41.8	790	(320)
- Silty Clay	11.5	230	(93)
TOTAL	164.0	3080	(1247)
Stony Phase:			
- Stone Free	94.5	1700	(688)
- Occasional Stones	45.5	900	(365)
- Moderately Stony	24.0	480	(194)
TOTAL	164.0	3080	(1247)

RESULTS AND DISCUSSION

QUALITY OF WORK

Penetration: Penetrating ability of the Model 807 chisel plow when equipped with 16 in (406 mm) sweeps was very good in all field conditions encountered.

Penetration was uniform across the cultivator width provided all depth linkages and hitch height were kept properly adjusted. The front stabilizer wheels minimized twisting of the wing frames. As with most rigid hitch cultivators, variations in tillage depth would occur in fields with abrupt contour changes.

Tillage depth required checking and appropriate adjustments made when changing fields to ensure uniform penetration of the Model 807.

Depth Uniformity: Flexibility of the chisel plow frame and shank characteristics (FIGURE 2) determine depth uniformity of the sweep. Width of the centre and wing sections and how they are linked together determine how well the unit follows the contours of the field. Shank stiffness and cushion spring preload may cause sweep pitch to become excessive, resulting in furrow bottom ridging, rapid sweep tip wear and increased draft. A shank which maintains a low, relatively constant sweep pitch over the normal range of tillage forces was desirable. PAMI has selected seven degrees as a maximum operating sweep pitch that will provide an acceptable furrow bottom for most operations.

Depth uniformity of the Model 807 was very good in both primary and secondary tillage conditions. The chisel plow, with its gauge wheels, followed rolling contours very well, maintaining uniform depth across the width. There was some variability when crossing gulleys or over sharp hill crests.

The sweep pitch characteristics of the Model 807 are shown in FIGURE 3. The no-load sweep pitch was 2 degrees. The lower sloped line shows how an increase in force gradually flexed the shank as indicated by a slight increase in sweep pitch. At a horizontal force of 500 lb (2.2 kN), the shank began to trip as the cushion-spring preload was overcome. This is the point on the curve where the steep upper curve begins. At a horizontal trip force of 680 lb (3.0 kN), the sweep pitch curve exceeded 7 degrees. This is the point where the steep curve crosses the broken horizontal line. If a cultivator is operated in conditions where soil forces exceed that value, a non-uniform furrow bottom will result.

Performance of the Model 807 can be determined by comparing its sweep pitch characteristics to the actual horizontal force that the shanks will encounter in the field. Research has been conducted to determine the typical prairie soil forces acting on soil tools located in the front row of a cultivator while operating at different depths in primary and secondary tillage

(APPENDIX II). The position and subsequent performance of the soil tools can be predicted by comparing the researched soil forces to the counteracting shank force (FIGURE 3) developed by the shank assembly.

The Model 807 shank force at a 7 degree sweep pitch was greater than all shown soil forces. This indicated that the 12 and 16 in (305 and 406 mm) sweeps will maintain a uniform tillage or seeding depth while operating in primary and secondary conditions. The Model 807 would also maintain 2 in (50 mm) spikes and banding knives at uniform working depth in primary and secondary conditions. This would minimize shank assembly wear as the soil forces would not be causing partial tripping or continuous movement of the assembly.

The cultivator shank configuration allowed for half a sweep overlap without running the wheel on cultivated soil. Running all wheels on untilled soil helps maintain uniform tillage depth.

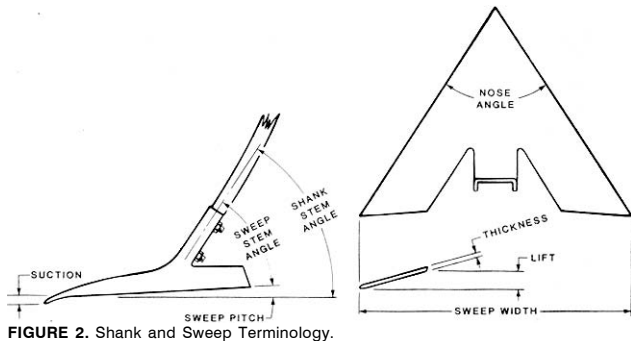

FIGURE 2. Shank and Sweep Terminology.

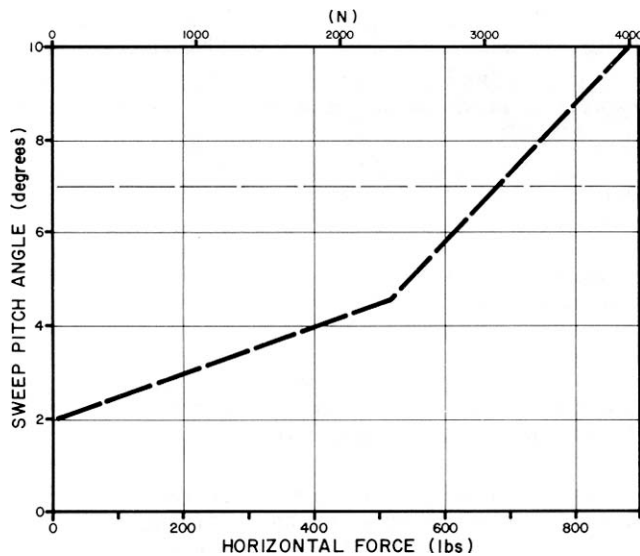

FIGURE 3. Sweep Pitch for Model 807 Shank.

Stone Protection: Stone protection was fair. FIGURE 4 shows the lifting pattern when shanks encounter stones or field obstructions. A lift height of 12 in (300 mm) normally prevents shank and sweep damage in fields with large rocks. The maximum lift height of the CI 807 shank assembly was 5 in (127 mm) when equipped with 16 in (406 mm) McKay sweeps. Three shanks bent while operating in stoney fields. It is recommended the manufacturer consider modifying the shank assembly to reduce shank damage when operating in rocky conditions.

Trash Clearance: The trash clearance of the 12 in (305 mm) shank spacing chisel plow was very good.

The 12 in (305 mm) lateral shank spacing and 24 in (610 mm) sweep-to-frame clearance was suitable for clearing large amounts of dry trash. In heavy, damp trash, plugging usually occurred at the wheel locations.

Surface Finish: The field surface finish was good with the Model 807 heavy duty chisel plow. In moderate trash conditions, the optional harrows were effective in distributing the trash

evenly when properly adjusted. In heavy trash, the harrows were placed into transport position to eliminate plugging. In light trash, the harrows were effective in levelling the ridges left by the chisel plow to produce a uniform seedbed.

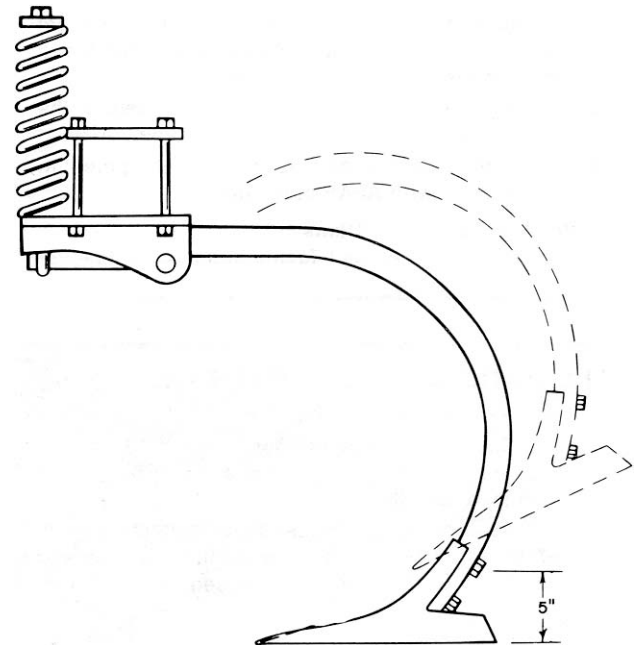

FIGURE 4. Shank Lifting Pattern.

Skewing and Stability: The Model 807 was stable and did not skew in typical field conditions. The sweep pattern (FIGURE 5) was symmetrical and did not impose any side forces on the chisel plow during tillage. Skewing was minimal even on hill-sides or where soil hardness varied across the machine width. With the 16 in (406 mm) sweeps, the chisel plow had to skew more than 2.5 degrees for weed misses to occur.

Weed Kill: Weed kill was good with the 16 in (406 mm) sweeps and 12 in (305 mm) shank spacing. Effective weed kill depends on soil and moisture conditions and the stage of weed growth. The finishing harrows were effective in exposing weeds in light trash conditions.

EASE OF OPERATION AND ADJUSTMENT

Maintenance: Lubrication was convenient, with good access to all grease fittings. The rocker shaft bearings and center frame hinges required greasing daily, while the gauge wheel pivot bearings required weekly greasing. The wheel bearings required annual servicing.

Transporting: Ease of transporting the Model 807 was very good. The hitch jack and rigid hitch link made one man hitching easy. Care had to be taken when disconnecting the chisel plow from the tractor because of the negative hitch weight caused by the addition of the optional harrows. It is recommended that the manufacturer consider balancing the cultivator by providing a rear jack or added hitch weight at front so an operator can safely hitch and unhitch the unit from his tractor.

The Model 807 was easily placed in transport position by one person in less than five minutes (FIGURE 6). Locks were provided for the wings and the center frame wheels. Wing transport locks were located towards the front of the chisel plow, while the center frame transport plates were located on the cylinder towers. All locks could be positioned without climbing on the chisel plow. The optional harrows could be individually locked in a raised position for greater ground clearance during transport.

Transport width of the test machine was 20.0 ft (6.1 m), while transport height was 13.9 ft (4.2 m). Normal care was needed when transporting on public roads, through gates, over bridges and beneath power lines.

Sufficient clearance between the tractor's rear tires and the chisel plow hitch allowed for sharp turns in both field and transport positions.

The Model 807 towed well without sway or bounce at normal transport speed. A sweep-to-ground clearance of 6.3 in (160 mm) was sufficient.

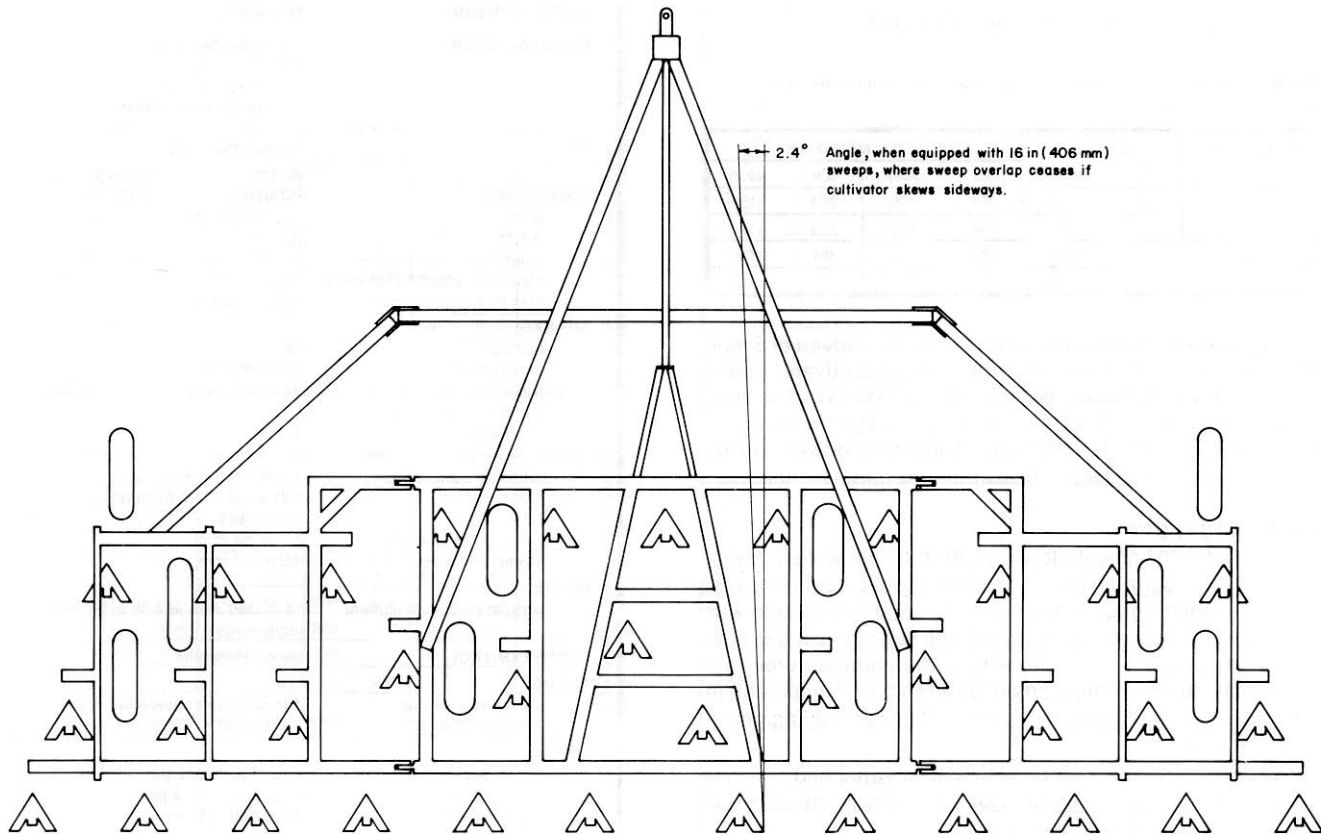

FIGURE 5. Sweep Pattern.

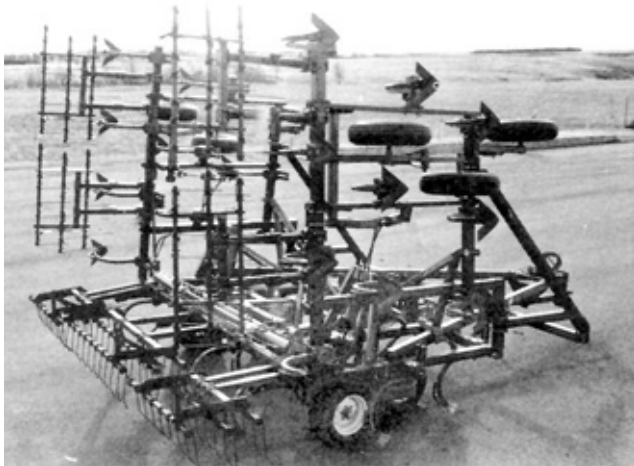

FIGURE 6. Transport Position.

Frame Levelling: Ease of levelling the frame was very good. Each set of wheels could be adjusted separately for lateral levelling. The main frame levelling was accomplished by adding or removing shim plates between the cylinder tower and cylinder anchor. Wing levelling was accomplished by loosening the jam nut on the cylinder anchor and then adjusting the bolt length until the wings were level with the main frame. Front-to-back levelling was accomplished by adjusting the hitch height. Hitch height could be adjusted 14 in (356 mm) in six increments by removing one bolt. This range was adequate to allow front-to-back frame levelling with all tractors used during the test.

Depth Adjustment: Ease of setting the tillage depth was very good. Tillage depth was controlled by four hydraulic cylinders connected in series; two on the center section and one on each wing section. A mechanical stop on the left center frame cylinder was adjusted to set tillage depth. To ensure uniform tillage depth, the hydraulic cylinders had to be synchronized periodically by completely extending them to a fully raised position.

Harrow Adjustment: Ease of adjusting the optional tine harrows was poor. The harrow frame was levelled by loosening two bolts and then rotating the harrow gang on the cross tube until the harrows were level with the chisel plow frame. The tine angle could be adjusted to seven different positions. Height and pressure adjustment required loosening the carriage bolt and adjusting the nuts on the adjusting clevis (FIGURE 7). It took the operator approximately one hour to adjust the seven tine harrows. It is recommended that the manufacturer consider modifying the height and pressure adjustment to improve operator convenience.

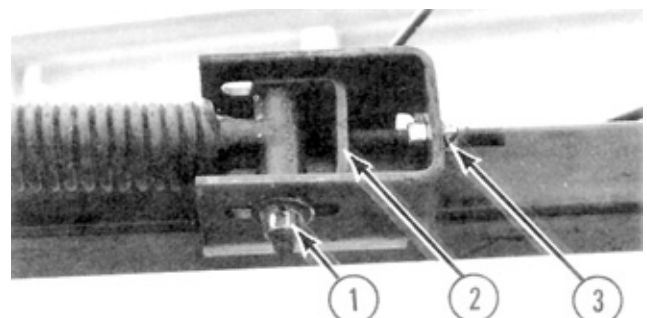

FIGURE 7. Harrow Tine Adjustment: (1) Carriage Bolt, (2) Adjusting Clevis, (3) Nuts.

POWER REQUIREMENTS

PAMI has measured power requirements on several cultivators in various field conditions as explained in APPENDIX III. From these field measurements, average power requirements have been determined to assist farmers in matching tractor and cultivator sizes. The tractor sizes (TABLE 2) have been adjusted to include tractive efficiency and represent a tractor operating at 80% of its maximum power take-off rating.

TABLE 2. Tractor Size: PTO Power (hp(kW)) Required to Operate the 35 ft (10.7 m) Model 807 Chisel Plow.

OPERATION	DEPTH in (mm)	SPEED - MPH (km/h)		
		5.0 (8.0)	6.0 (9.7)	
PRIMARY	3.0 (75)	168 (125)	203 (152)	
	4.0 (100)	214 (159)	259 (194)	
SECONDARY	3.0 (75)	151 (112)	182 (136)	
	4.0 (100)	196 (147)	238 (178)	

In typical secondary tillage conditions at a speed of 5 mph (8 km/h) and a depth of 3 in (75 mm), average cultivator power requirements for the Model 807 was 151 hp (112 kW). The average power requirements at the same speed and depth in primary tillage was 203 hp (152 kW). Additional power will be required when tilling deeper or working in hilly terrain.

OPERATOR SAFETY

The Model 807 chisel plow was 20 ft (6.1 m) wide in transport, which necessitated caution when towing on public roads, over bridges and through gates. A slow moving vehicle sign was provided as standard equipment, while the safety chain was supplied as an option. It is recommended the manufacturer consider supplying the safety chain as standard equipment in accordance with the American Society of Agricultural Engineers' safety standards.

When in transport position with harrows attached, the load on the center section tires did not exceed the Tire and Rim Association's maximum load rating.

OPERATOR'S MANUAL

The operator's manual for the CI Model 807 was very good. It contained useful information on safety, assembly, adjustment, specifications, maintenance and operation. A detailed parts list was also included.

MECHANICAL HISTORY

TABLE 3 outlines the mechanical history of the Model 807 chisel plow during 164 hours of field operation while cultivating 3080 ac (1247 ha). The intent of the test was evaluation of functional performance. An extended durability evaluation was not conducted.

TABLE 3. Mechanical History

ITEM	OPERATING HOURS	EQUIVALENT FIELD AREA	
		ac	(ha)
- Replaced five broken sweeps at	63, 65	1350, 1386	(547, 561)
- Replaced three bent shanks at	63, 65	1350, 1386	(547, 561)
- Replaced twenty expansion pins at	91	1728	(700)

Shanks: Three shanks bent while operating in rocky field conditions. Insufficient lift height was the probable cause for the shank damage. Modifications have already been recommended.

APPENDIX I

SPECIFICATIONS

MAKE:	Cereal Implements		
MODEL:	807		
SERIAL NUMBER:	66008-00010		
MANUFACTURER:	Vicon Western Canada P.O. Box 3200 1000 Sixth Avenue NE Portage La Prairie, Manitoba R1N 3R3 Phone (204) 239-7011		
DIMENSIONS:	FIELD POSITION	TRANSPORT POSITION	
	- width	36.2 ft (11.0 m)	18.4 ft (5.7 m)
	- length	25.4 ft (7.8 m)	25.4 ft (7.8 m)
	- height	6.6 ft (2.0)	13.9 ft (4.2 m)
	- maximum ground clearance	6.3 in (160 mm)	6.3 in (160 mm)
	- maximum wheel tread	29.2 ft (8.9 m)	11.9 ft (3.6 m)
SHANKS:			
	- number	35	
	- lateral spacing	12 in (305 mm)	
	- trash clearance	24 in (610 mm)	
	- number of shank rows	4	
	- center	3	
	- wings	1.9 to 3.9 ft (0.6 to 1.2 m)	
	- distance between rows	1.25 x 2 in (32 x 51 mm)	
	- cross section	45 degrees	
	- stem angle	2.5 in (64 mm)	
	- sweep hole spacing	0.5 in (13 mm)	
	- sweep bolt size		
HITCH:			
	- vertical range adjustment	14 in (360 mm) in 2.36 in (60 mm) increments	
DEPTH CONTROL:		Series Hydraulic	
FRAME:			
	- main cross section	4 in (102 mm) square tubing	
	- wing cross section	2 x 4 in (51 x 102 mm) tubing	
TIRES:			
	- center section	Four, 11L - 15, 8 ply	
	- wing sections	Four, 7.60 - 15, 4 ply	
	- stabilizer wheels	Two, 7.60 - 15, 4 ply	
NUMBER OF LUBRICATION POINTS:			
	- grease fittings	16	
	- wheel bearings	10	
HYDRAULIC CYLINDERS:			
	- depth control	One, 4.25 x 8 in (108 x 204 mm) One, 4.0 x 8 in (102 x 204 mm) One, 3.75 x 8 in (95 x 204 mm) One, 3.5 x 8 in (89 x 204 mm) Two, 4.0 x 28 in (102 x 711 mm)	
	- wing lift		
WEIGHTS (without harrows):	FIELD POSITION	TRANSPORT POSITION	
	- hitch	4001b (182 kg)	630 lb (286 kg)
	- right wheels	2140 lb (973 kg)	
	- right center	3230 lb (1468 kg)	5240 lb (2382 kg)
	-left center	3150 lb (1432 kg)	5130 lb (2332 kg)
	-left wheels	2080 lb (945 kg)	
	TOTAL	11000 lb (5000 kg)	11000 lb (5000 kg)
OPTIONAL EQUIPMENT AVAILABLE:			
	- 8 width options from 25 to 41 ft (7.6 to 12.5 m)		
	- 5 to 7 ft (1.5 to 2.1 m) width three row mounted harrows, optional transport lock and lift kit available for harrows		

**APPENDIX II
SOIL FORCE TABLES**

The following tables give typical horizontal forces acting on sweeps, spikes, and banding knives located in the front row of a cultivator while operating at different depths in primary and secondary tillage on the prairies. Higher forces may be encountered in extremely heavy, dry or compacted soils.

These values can be used to determine how well the shank assemblies are suited to the various operations. Comparing the sweep pitch curve of the assembly to these soil forces will indicate whether the assembly will hold the soil tool below the acceptable 7 degree sweep pitch.

TABLE 4. Forces Required (lb (kN)) in Primary Tillage for Various Soil Tools.

DEPTH in (mm)	SWEEPS						SPIKE 2 in (50 mm)	BANDING KNIFE 1 in (25 mm)
	FIELD CULT.		HEAVY DUTY CULT.					
	11 in (275 mm)	12 in (305 mm)	16 in (406 mm)					
lb (kN)	lb (kN)	lb (kN)	lb (kN)	lb (kN)	lb (kN)	lb (kN)	lb (kN)	
2 (50)	120 (0.5)	190 (0.8)	220 (1.0)	---		---	---	
3 (75)	140 (0.6)	230 (1.0)	280 (1.2)	150 (0.7)		---		
4 (100)	180 (0.8)	310 (1.4)	370 (1.6)	190 (0.8)		320 (1.4)		
5 (125)	---	420 (1.9)	500 (2.2)	260 (1.2)		390 (1.7)		
6 (150)	---	---	---	360 (1.6)		540 (2.4)		

TABLE 5. Forces Required (lb (kN)) in Secondary Tillage for Various Soil Tools.

DEPTH in (mm)	SWEEPS						SPIKE 2 in (50 mm)	BANDING KNIFE 1 in (25 mm)
	FIELD CULT.		HEAVY DUTY CULT.					
	11 in (275 mm)	12 in (305 mm)	16 in (406 mm)					
lb (kN)	lb (kN)	lb (kN)	lb (kN)	lb (kN)	lb (kN)	lb (kN)	lb (kN)	
2 (50)	110 (0.5)	170 (0.8)	200 (0.9)	---		---	---	
3 (75)	140 (0.6)	220 (1.0)	270 (1.2)	130 (0.6)		---		
4 (100)	170 (0.8)	280 (1.2)	340 (1.5)	180 (0.8)		290 (1.3)		
5 (125)	---	370 (1.6)	450 (2.0)	290 (1.1)		380 (1.7)		
6 (150)	---	---	---	320 (1.4)		490 (2.2)		

**APPENDIX III
POWER REQUIREMENTS**

Draft Characteristics: Draft requirements have been measured on several cultivators in various field conditions over the past years. Average draft requirements have been determined from these requirements.

Draft requirements for the same cultivator, in the same field, may vary by as much as 30% in two different years due to changes in soil conditions. Variations in soil conditions affect draft much more than variations in machine make, making it difficult to measure any significant draft differences between make of cultivators.

Since there is little or no draft differences between machines, PAMI has averaged the results obtained over the years and has used these to determine tractor size requirements.

Recommended Tractor Size: The following tables show tractor PTO power required to pull cultivators in various conditions at the given depths and speeds. Tractor power requirements have been adjusted to include a tractive efficiency of 80% in primary and 70% in secondary tillage and represent a tractor operating at 80% of maximum PTO power on a level field. These power requirements can be used along with the maximum PTO ratings, as determined by Nebraska tests or as presented by the tractor manufacturer, to select the appropriate tractor. Higher power will be required in hills or in heavy soils. Cultivators with marked differences in spacing, number of rows, or configuration may require more or less power.

Recommended tractor size may be determined by selecting the required horsepower per foot from the appropriate table and multiplying by the width of the cultivator. For example, in primary tillage at 4 in (100 mm) and 5 mph (8 km/h), 6.1 hp/ft (14.9 kW/m) is required. Therefore, for a 41.3 ft (12.5 m) cultivator in those conditions, 250 PTO hp (185 kW) is recommended.

TABLE 6. Tractor PTO Power Per Unit Width (hp/ft (kW/m)) Required in Primary Tillage.

DEPTH in (mm)	SPEED - MPH (km/h)					
	4.0 (6.4)	5.0 (8.0)	6.0 (9.7)			
2 (50)	2.7 (6.6)	3.4 (8.3)	4.1 (10.0)			
3 (75)	3.8 (9.3)	4.8 (11.7)	5.8 (14.2)			
4 (100)	4.9 (12.0)	6.1 (14.9)	7.4 (18.1)			
5 (125)	6.0 (14.7)	7.5 (18.4)	9.0 (22.0)			

TABLE 7. Tractor PTO Power Per Unit Width (hp/ft (kW/m)) Required in Secondary Tillage.

DEPTH in (mm)	SPEED - MPH (km/h)					
	4.0 (6.4)	5.0 (8.0)	6.0 (9.7)			
2 (50)	2.3 (5.6)	3.0 (7.3)	3.6 (8.8)			
3 (75)	3.4 (8.3)	4.3 (10.5)	5.2 (12.7)			
4 (100)	4.5 (11.0)	5.6 (13.7)	6.8 (16.6)			
5 (125)	5.5 (13.5)	7.0 (17.1)	8.4 (20.6)			

**APPENDIX IV
MACHINE RATINGS**

The following rating scale is used in PAMI Evaluation Reports:

- Excellent
- Very Good
- Good
- Fair
- Poor
- Unsatisfactory

SUMMARY CHART

CEREAL IMPLEMENTS MODEL 807 CHISEL PLOW

RETAIL PRICE:	\$22,526.00 (March, 1988 f.o.b. Lethbridge 35 ft (10.7 m) width, optional harrows and McKay sweeps.
QUALITY OF WORK:	
Penetration	Very Good; could be set to provide level furrow bottom in secondary and primary conditions.
Depth Uniformity	Very Good
Stone Protection	Fair; trip height was 5 in (127 mm)
Trash Clearance	Very Good; would plug in heavy trash
Surface Finish	Good
Weed Kill	Good
EASE OF OPERATION AND ADJUSTMENT:	
Transporting	Very Good; negative hitch weight when harrows were attached
Frame Levelling	Very Good
Depth Adjustment	Very Good
Harrow Adjustment	Poor; time consuming when adjusting height and pressure of harrows
POWER REQUIREMENTS:	
Secondary Tillage	151 hp (112 kW) at 3 in (75 mm) and 5 mph (8 km/h)
Primary Tillage	203 hp (152 kW) at 3 in (75 mm) and 5 mph (8 km/h)
OPERATOR SAFETY:	Good; if normal safety procedures were observed.
OPERATOR'S MANUAL:	Very Good; well written and clearly illustrated.
MECHANICAL HISTORY:	Three bent shanks, five broken sweeps and twenty expansion pins were replaced.



**ALBERTA
FARM
MACHINERY
RESEARCH
CENTRE**

3000 College Drive South
Lethbridge, Alberta, Canada T1K 1L6
Telephone: (403) 329-1212
FAX: (403) 329-5562
<http://www.agric.gov.ab.ca/navigation/engineering/afmrc/index.html>

Prairie Agricultural Machinery Institute

Head Office: P.O. Box 1900, Humboldt, Saskatchewan, Canada S0K 2A0
Telephone: (306) 682-2555

Test Stations:

P.O. Box 1060

Portage la Prairie, Manitoba, Canada R1N 3C5

Telephone: (204) 239-5445

Fax: (204) 239-7124

P.O. Box 1150

Humboldt, Saskatchewan, Canada S0K 2A0

Telephone: (306) 682-5033

Fax: (306) 682-5080