

# Evaluation Report

# 567



## Morris Magnum II CP-725 Chisel Plow

A Co-operative Program Between



## MORRIS MAGNUM CP-725 CHISEL PLOW

### MANUFACTURER AND DISTRIBUTOR:

Morris Rod-Weeder Co. Ltd.  
85 York Road  
Yorkton, Saskatchewan  
S3N 2X3  
Phone: (306) 783-8585

### RETAIL PRICE:

\$17,582.00 (July, 1988, f.o.b. Lethbridge, Alberta, 25.3 ft. (7.7 m) wide machine complete with duals on main frame and 4-bar mounted harrows).

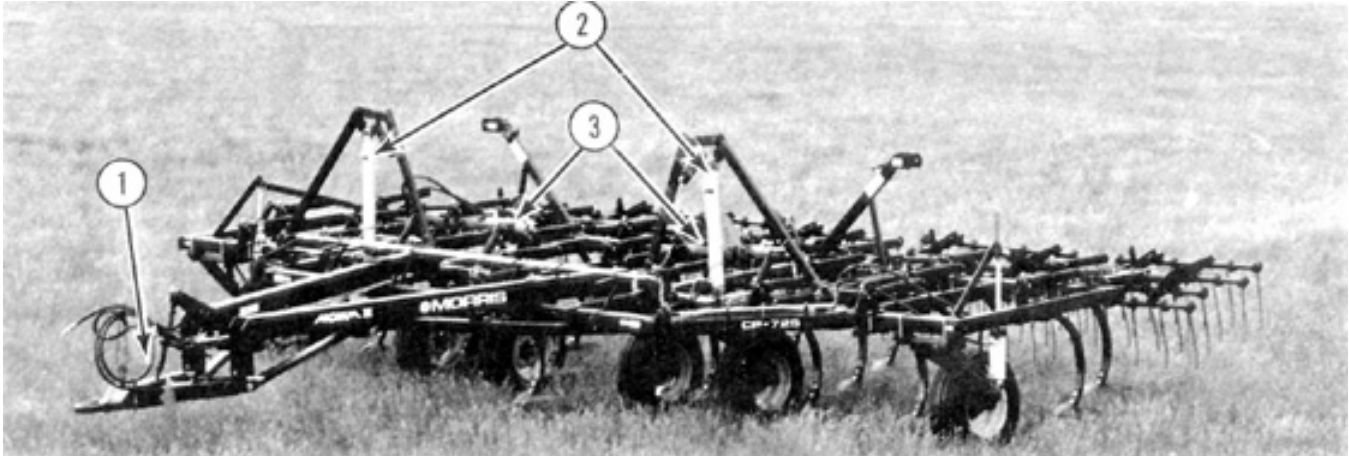

FIGURE 1. Morris Magnum II CP-725 Chisel Plow: (1) A-Frame Hitch, (2) Wing Lift Cylinder, (3) Depth Control Cylinder.

### SUMMARY OF RESULTS

**Quality of Work:** The Morris CP-725 chisel plow was suitable for primary and secondary tillage. Penetration was very good with the 16 in (406 mm) sweeps at t2 in (305 mm) shank spacing. Depth uniformity was very good. Laboratory testing of the Morris CP-725 shank assembly showed it would maintain a uniform tillage or seeding depth while operating in primary and secondary tillage.

The maximum lift height of the shank assembly was 10 in (254 mm) when equipped with 16 in (406 mm) sweeps. This lift height provided good stone protection.

Trash clearance at the 12 in (305 mm) shank spacing was very good. With the optional harrows attached, the surface finish left by the Morris CP-725 in light loose trash was good. The harrows were not used in heavy trash conditions.

The Morris CP-725 was stable but did skew in gently to moderately rolling field conditions but did not affect its overall performance.

**Ease of Operation and Adjustment:** Transporting the Morris CP-725 chisel plow was very good. The hitch jack and A-Frame hitch made one man hitching easy. If the optional harrows were attached, positive hitch weight was still maintained.

Ease of levelling the frame was very good. Front-to-back levelling was accomplished by adjusting the ratchet jack on the A-Frame hitch member. There was an adjustable cylinder control rod on each depth cylinder for lateral levelling. Ease of setting the tillage depth was very good. A depth control rod on the left wing depth cylinder was adjusted to set the tillage depth. Ease of setting the harrows was good.

**Power Requirements:** In secondary tillage at 3 in (75 mm) and 5 mph (8 km/h), a tractor with 109 hp (81 kW) PTO horsepower is required. At the same speed and depth in primary tillage, 121 hp (91 kW) PTO horsepower is required.

**Operator Safety:** Operation of the Morris CP-725 chisel plow was safe provided normal safety procedures

were observed. No safety chain was supplied for on-road transportation.

**Operator's Manual:** The operator's manual was good, containing useful information on safety, assembly, adjustment, specifications, maintenance and operation. A detailed parts list was also included.

**Mechanical History:** A few minor mechanical problems occurred during the test.

### RECOMMENDATIONS

It is recommended that the manufacturer consider:

1. Supplying a safety chain as standard equipment in accordance with ASAE safety standards.
2. Supplying a more detailed maintenance schedule.

Station Manager: R. P. Atkins

Project Technologist: G. A. Magyar

### THE MANUFACTURER STATES THAT

With recommendation number:

1. We will probably be making a safety chain as standard equipment to comply with the ASAE safety standards.
2. Our Product Communications Department will be notified to include a more detailed maintenance schedule in our Operator's Manual.

### GENERAL DESCRIPTION

The Morris Magnum II CP-725 chisel plow is a trailing, three section chisel plow suitable for primary and secondary tillage

operations. The 25.3 ft (7.7 m) wide machine has a 13 ft (4.0 m) center frame and two 6 ft (1.8 m) wing sections. The unit has 25 spring-trip shanks, arranged in three rows and spaced at 12 in (305 mm) intervals.

The center frame is supported by four wheels, while each wing frame is supported by a single wheel. Four hydraulic cylinders connected in series control tillage depth. The wings fold into transport position with two hydraulic cylinders connected in parallel. A tractor with dual remote hydraulic controls is needed to operate the Morris CP-725. The test machine is equipped with optional four row tine harrows and dual right and left main frame axle assemblies.

The Morris CP-725 is available in widths from 25.3 ft (7.7 m) to 29 ft (8.8 m). Three row or four row tine harrows, offset dual right and left axle assemblies, ball type and hammerstrap hitch clevises, heavy duty kits for the hitch and frame members and rigid or heavy duty shank assemblies are available as optional equipment.

Detailed specifications are given in APPENDIX I and FIGURE 1 shows the location of major components.

## SCOPE OF TEST

The Morris CP-725 was tested during seeding operations in conjunction with Morris MA-170 Air Seeder Evaluation Report #542 and Morris Air Hoe Packer Attachment Evaluation Report #571 and tillage operations in field conditions as shown in TABLE 1, for approximately 225 hours while cultivating about 2690 ac (1089 ha). It was evaluated for quality of work, ease of operation and adjustment, power requirements, operator safety, and suitability of the operator's manual.

TABLE 1. Operating Conditions.

FIELD CONDITIONS	HOURS	FIELD AREA	
		ac	(ha)
Operation:			
- Primary	120.5	1305	( 528)
- Secondary	104.5	1385	( 561)
<b>TOTAL</b>	<b>225.0</b>	<b>2690</b>	<b>(1089)</b>
Soil Type:			
- Silt Loam	159.0	1990	( 806)
- Loam	43.5	480	( 194)
- Clay	22.5	220	( 89)
<b>TOTAL</b>	<b>225.0</b>	<b>2690</b>	<b>(1089)</b>
Stony Phase:			
- Stone Free	57.5	690	( 279)
- Occasional Stones	141.5	1685	( 682)
- Moderately Stony	26.0	315	( 128)
<b>TOTAL</b>	<b>225.0</b>	<b>2690</b>	<b>(1089)</b>

## RESULTS AND DISCUSSION

### QUALITY OF WORK

**Penetration:** Penetrating ability of the Morris CP-725 chisel plow when equipped with 16 in (406 mm) sweeps was very good in all field conditions encountered.

Penetration was uniform across the cultivator width provided all depth linkages and hitch height were kept properly adjusted. The narrow width of the wings prevented their frames from twisting. As with most rigid hitch cultivators, variations in tillage depth would occur in fields with abrupt contour changes.

Maintaining tillage depths required checking and making appropriate adjustments when changing fields to ensure uniform penetration of the Morris CP-725 chisel plow.

**Depth Uniformity:** Flexibility of the chisel plow frame and shank characteristics (FIGURE 2) determine depth uniformity of the sweeps. Width of the centre and wing sections and how they are linked together determine how well the unit follows the contours of the field. Shank stiffness and cushion spring preload may cause sweep pitch to become excessive, result-

ing in furrow bottom ridging, rapid sweep tip wear and increased draft. A shank which maintains a low, relatively constant sweep pitch over the normal range of tillage forces was desirable. PAMI has selected seven degrees as a maximum operating steep pitch that will provide an acceptable furrow bottom for most operations.

Depth uniformity of the Morris CP-725 was very good in both primary and secondary tillage conditions. The chisel plow followed rolling contours very well, maintaining uniform depth across the full width. There was some depth variation when crossing gullies or over sharp hill crests.

The sweep pitch characteristics of the Morris CP-725 are shown in FIGURE 3. The no-load sweep pitch was 2 degrees. The lower portion of the line shows how an increase in force gradually flexed the shank as indicated by a slight increase in sweep pitch. At a horizontal force of 870 lb (3.9 kN), the shank began to trip as the spring-trip preload was overcome. The point on the curve where the sweep pitch curve exceeded 7 degrees was at 800 lb (3.6 kN). The curve above the 7 degree line shows how shank force decreases as the shank trips over an obstacle.

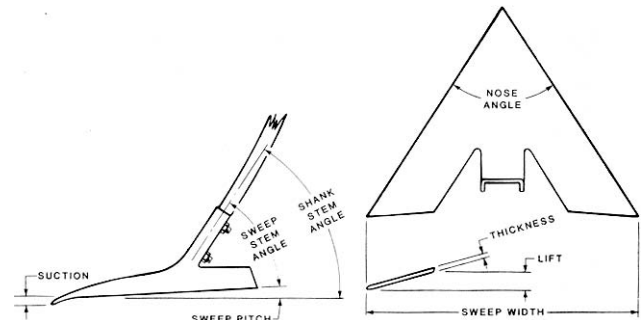

FIGURE 2. Shank and Sweep Terminology.

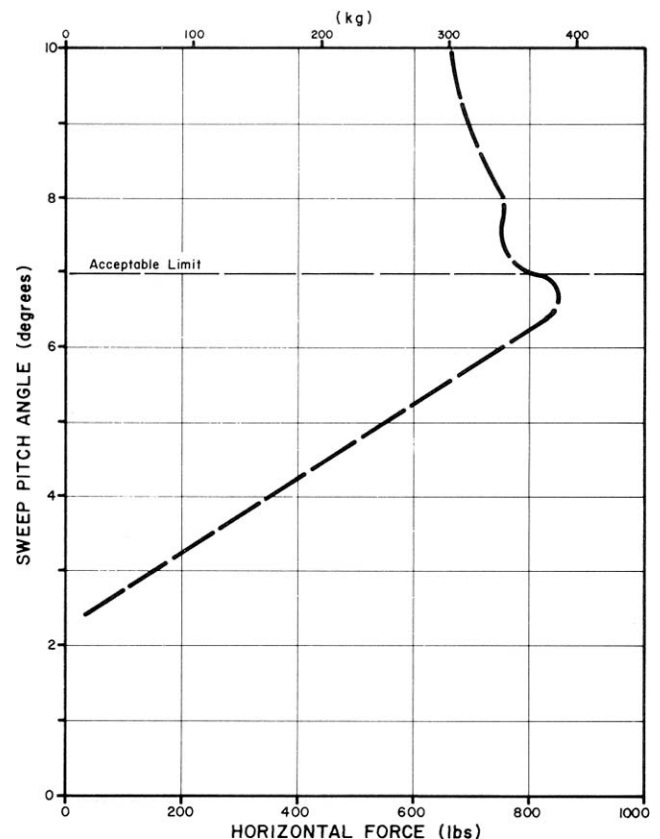

FIGURE 3. Sweep Pitch for Morris CP-725 Shank.

Performance of the Morris CP-725 can be determined by comparing its sweep pitch characteristics to the actual horizon-

tal force that the shanks will encounter in the field. Research has been conducted to determine the typical prairie soil forces acting on soil tools located in the front row of a cultivator while operating at different depths in primary and secondary tillage (APPENDIX II). The position and subsequent performance of the soil tools can be predicted by comparing the researched soil forces to the counteracting shank force (FIGURE 3) developed by the shank assembly.

The Morris CP-725 shank force at a 7 degree sweep pitch was greater than all shown soil forces. This indicates that the 12 and 16 in (305 and 406 mm) sweeps will maintain a uniform tillage or seeding depth while operating in primary and secondary tillage. The Morris CP-725 would also maintain 2 in (50 mm) spikes and banding knives at uniform working depth in primary and secondary conditions. This would minimize shank assembly wear as the soil forces would not be causing partial tripping or continuous movement of the assembly.

**Stone protection:** Stone protection was very good.

FIGURE 4 shows the lifting pattern when shanks encounter stones or field obstructions. A lift height of 12 in (300 mm) normally prevents shank and sweep damage in fields with large rocks. The maximum lift height of the Morris CP-725 shank assembly was 10 in (254 mm) when equipped with 16 in (406 mm) sweeps. There was no shank damage during the test period.

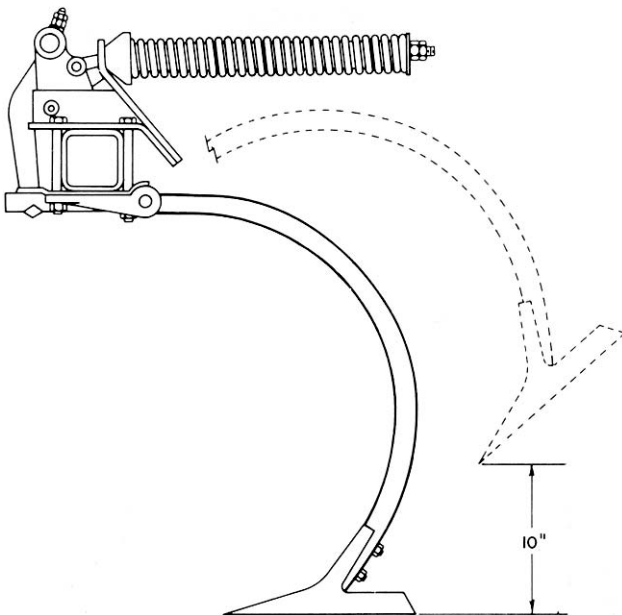

FIGURE 4. Shank Lifting Pattern.

**Trash Clearance:** The trash clearance of the 12 in (305 mm) shank spacing chisel plow was very good.

The 12 in (305 mm) lateral shank spacing and 27 in (686 mm) sweep-to-frame clearance was suitable for clearing large amounts of dry trash.

**Surface Finish:** The field surface finish was good with the Morris CP-725 chisel plow.

In moderate trash conditions, the optional harrows were effective in distributing the trash evenly when properly adjusted. In heavy trash, the harrows were placed into transport position to eliminate plugging. In light trash, the harrows were effective in levelling the ridges left by the chisel plow to produce a uniform seedbed.

**Skewing and Stability:** The Morris CP-725 was stable and did not skew in typical field conditions. The sweep pattern (FIGURE 5) was symmetrical and did not impose any side forces on the chisel plow during tillage. Skewing was minimal even on hillsides or where soil hardness varied across the machine width. With the 16 in (406 mm) sweeps, the chisel plow had to skew more than 2.5 degrees for weed misses to occur.

## EASE OF OPERATION AND ADJUSTMENT

**Maintenance:** Lubrication was convenient with good access to all grease fittings. The shank trip rocker pins were greased every 50 hours while the wheel axles and ratchet jack were greased as required and the wheel hubs were greased until the grease leaked by the seals. It is recommended that the manufacturer consider supplying a more detailed maintenance schedule for the Morris CP-725 chisel plow.

**Transporting:** Ease of transporting the Morris CP-725 chisel plow was very good.

The hitch jack and A-Frame hitch member made one man hitching easy. The Morris CP-725 was easily placed in transport position by one person in less than five minutes (FIGURE 6). Locks were provided for the wings and the center frame wheels. Wing transport locks were located at the rear of the chisel plow while the center frame transport locks could be positioned without climbing on the chisel plow. The optional harrows could be individually locked in a raised position for greater ground clearance during transport.

Transport width of the test machine was 20 ft (6.1 m) while transport height was 10.8 ft (3.3 m). Normal care was needed when transporting on public roads, through gates, over bridges and beneath power lines.

Sufficient clearance between the tractor rear tires and the chisel plow hitch allowed for sharp turns in both field and transport positions.

The Morris CP-725 towed well without sway or bounce at normal transport speed. A sweep-to-ground clearance of 7.0 in (178 mm) was sufficient.

**Frame Levelling:** Ease of levelling the frame was very good. Each wheel or wheel set could be adjusted separately for lateral levelling. Levelling was accomplished by loosening the jam nut on the cylinder anchor and then adjusting the bolt length until the appropriate frame was level. Front-to-back levelling was accomplished by adjusting the ratchet jack on the A-Frame hitch member (FIGURE 8). The A-Frame allowed for an infinite range of hitch heights.

**Depth Adjustment:** Ease of setting the tillage depth was very good. Tillage depth was controlled by four hydraulic cylinders connected in series; two on the center section and one on each wing section. A depth control rod on the left wing depth cylinder was adjusted to set tillage depth. To ensure uniform tillage depth, the hydraulic cylinders had to be synchronized periodically by completely extending them to a fully raised position.

**Harrow Adjustment:** Ease of adjusting the optional tine harrows was very good. The harrow frame was levelled by loosening two bolts and then rotating the harrow gang on the cross tube until the harrows were level with the chisel plow frame. The tine angle could be adjusted to six different positions.

## POWER REQUIREMENTS

PAMI has measured power requirements on several cultivators in various field conditions as explained in APPENDIX III. From these field measurements, average power requirements have been determined to assist farmers in matching tractor and cultivator sizes. The tractor sizes (TABLE 2) have been adjusted to include tractive efficiency and represent a tractor operating at 80% of maximum power take-off rating.

TABLE 2. Tractor Size: PTO Power (hp(kW)) Required to Operate a Typical 25.3 ft (7.7 m) Chisel Plow.

OPERATION	DEPTH		SPEED - MPH (km/h)			
	in	(mm)	5.0	(8.0)	6.0	(9.7)
PRIMARY	3.0	( 75)	123	( 92)	150	(112)
	4.0	(100)	157	(118)	191	(143)
SECONDARY	3.0	( 75)	111	( 83)	134	(100)
	4.0	(100)	144	(108)	175	(131)

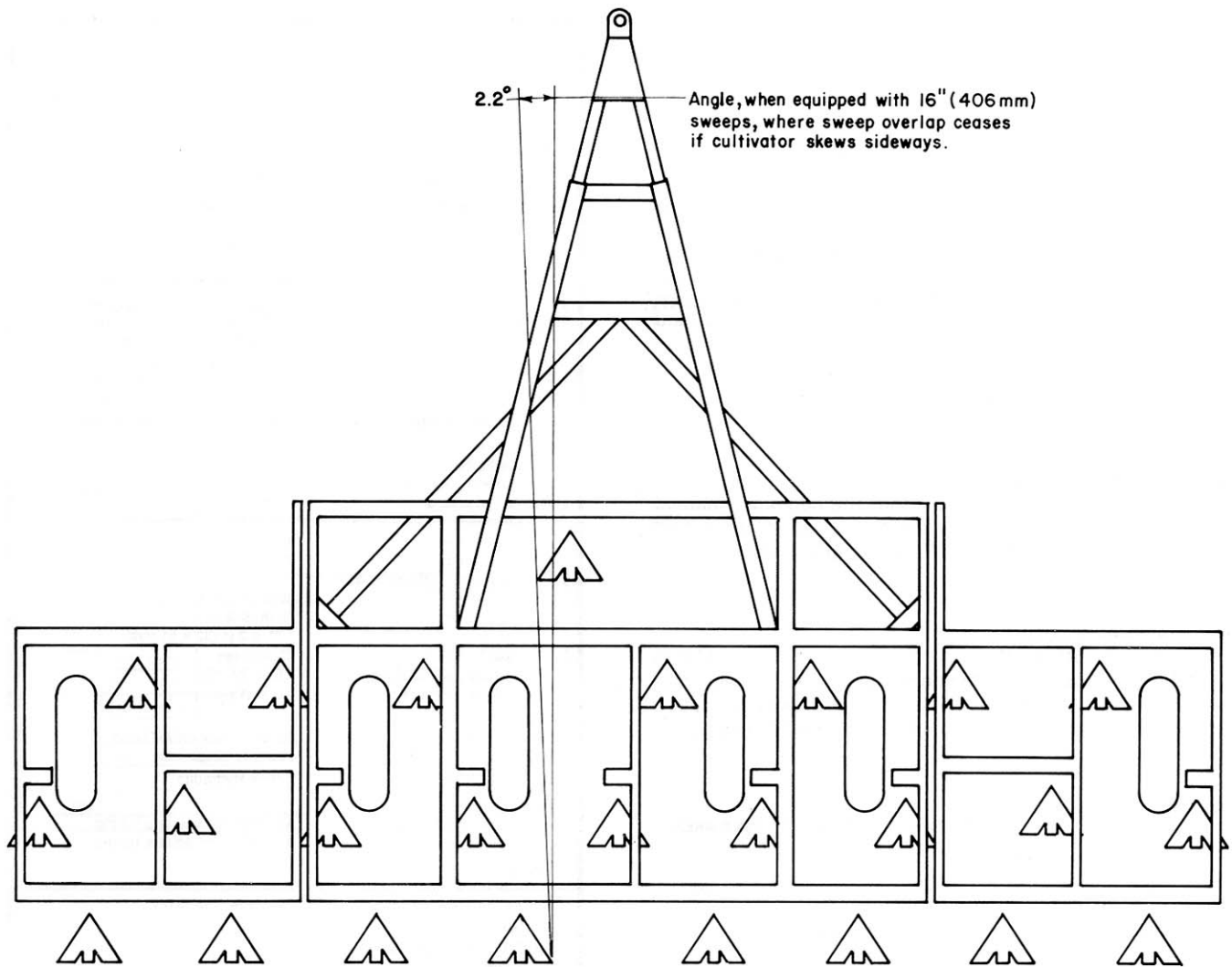

FIGURE 5. Sweep Pattern.

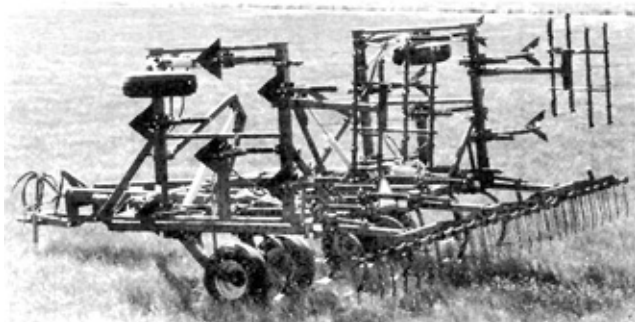

FIGURE 6. Transport Position.

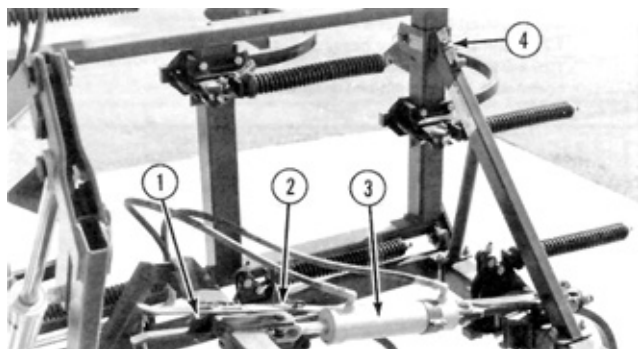

FIGURE 7. Transport Locks: (1) Wedge, (2) Depth Transport Lock-Arm, (3) Depth Cylinder, (4) Wing Lock.

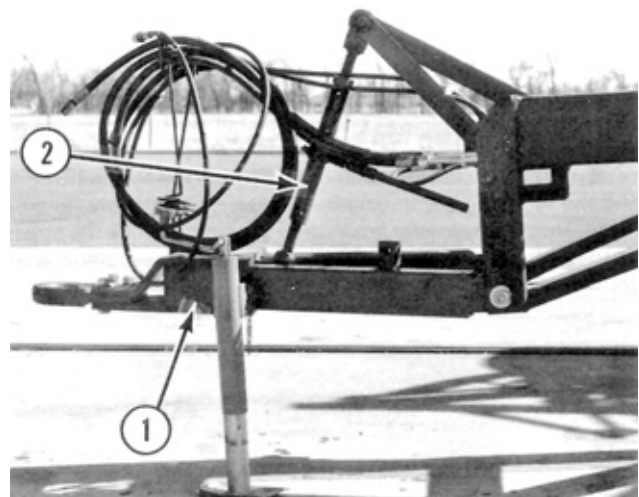

FIGURE 8. A-Frame Hitch: (1) A-Frame Hitch, (2) Ratchet Jack.

In typical secondary tillage conditions at a speed of 5 mph (8 km/h) and a depth of 3 in (75 mm), average cultivator power requirements were 4.3 hp/ft (10.5 kW/m) (APPENDIX III). In typical primary tillage conditions at the same speed and depth average power requirements were 4.8 hp/ft (11.7 kW/m). Therefore, the tractor PTO horsepower recommended to 25.3 ft (7.7 m) of Morris CP-725 chisel plow under these conditions would be 109

hp (81 kW) in secondary conditions and 121 hp (91 kW) in primary conditions. Additional power will be required when tilling deeper or working in hilly terrain.

**OPERATOR SAFETY**

The Morris CP-725 chisel plow was 20 ft (6.1 m) wide in transport, which necessitated caution when towing on public roads, over bridges, through gates and under power lines. A slow moving vehicle sign was provided as standard equipment. A hitch safety chain for transporting on public roads was not supplied. It is recommended that the manufacturer consider supplying the safety chain as standard equipment in accordance with American Society of Agricultural Engineer's safety standards.

When in transport position with harrows attached, the load on the center section tires did not exceed The Tire and Rim Association's maximum load rating.

**OPERATOR'S MANUAL**

The operator's manual was good. The operator's manual for the Morris CP-725 chisel plow contained useful information on safety, assembly, adjustment, specifications and operation. A detailed parts list was also included.

**MECHANICAL HISTORY**

TABLE 3 outlines the mechanical history of the Morris CP-725 chisel plow during 225 hours of field operation while cultivating 2690 ac (1089 ha). The intent of the test was evaluation of functional performance. An extended durability evaluation was not conducted.

TABLE 3. Mechanical History

ITEM	OPERATING HOURS	EQUIVALENT FIELD AREA	
		ac	(ha)
- Repositioned right wing bracket at	7.0	105	(43)
- Repaired hydraulic leak on left wing depth cylinder at	120.5	1810	(733)
- Replaced damaged harrow tine bar at	135.3	2032	(823)
- Installed new seal kit on left wing depth cylinder at	135.5	2032	(823)
- Replaced broken harrow spring rod at	135.5	2032	(823)

**Right Wing Bracket:** The right wing bracket was shifted over so that the locking pin was easier to install. No further problems were encountered.

**Hydraulic Leak:** The connector between the hydraulic hose and the left wing depth cylinder leaked continuously. To stop the leaking the hydraulic hose was rerouted to reduce the stress on the hydraulic hose and connector. No further problems were encountered.

**APPENDIX I**

**SPECIFICATIONS**

<b>MAKE:</b>	Morris																											
<b>MODEL:</b>	Magnum II CP-725																											
<b>SERIAL NUMBER:</b>	16713																											
<b>MANUFACTURER:</b>	Morris Rod-Weeder Co. Ltd. 85 York Road Yorkton, Saskatchewan S3N 2X2 Phone (306) 783-8585																											
<b>DIMENSIONS:</b>	<table border="0"> <tr> <td></td> <td><b>FIELD POSITION</b></td> <td><b>TRANSPORT POSITION</b></td> </tr> <tr> <td>- width</td> <td>25.8 ft (7.9 m)</td> <td>20.0 ft (6.1 m)</td> </tr> <tr> <td>- length</td> <td>20.5 ft (6.2 m)</td> <td>20.5 ft (6.2 m)</td> </tr> <tr> <td>- height</td> <td>6.7 ft (2.0)</td> <td>9.3 ft (2.8 m)</td> </tr> <tr> <td>- maximum ground clearance</td> <td>7.0 in (179 mm)</td> <td>7.0 in (178 mm)</td> </tr> <tr> <td>- maximum wheel tread</td> <td>22.8 ft (7.0 m)</td> <td>10.8 (3.3 m)</td> </tr> </table>		<b>FIELD POSITION</b>	<b>TRANSPORT POSITION</b>	- width	25.8 ft (7.9 m)	20.0 ft (6.1 m)	- length	20.5 ft (6.2 m)	20.5 ft (6.2 m)	- height	6.7 ft (2.0)	9.3 ft (2.8 m)	- maximum ground clearance	7.0 in (179 mm)	7.0 in (178 mm)	- maximum wheel tread	22.8 ft (7.0 m)	10.8 (3.3 m)									
	<b>FIELD POSITION</b>	<b>TRANSPORT POSITION</b>																										
- width	25.8 ft (7.9 m)	20.0 ft (6.1 m)																										
- length	20.5 ft (6.2 m)	20.5 ft (6.2 m)																										
- height	6.7 ft (2.0)	9.3 ft (2.8 m)																										
- maximum ground clearance	7.0 in (179 mm)	7.0 in (178 mm)																										
- maximum wheel tread	22.8 ft (7.0 m)	10.8 (3.3 m)																										
<b>SHANKS:</b>	<table border="0"> <tr> <td>- number</td> <td>25</td> </tr> <tr> <td>- lateral spacing</td> <td>12 in (305 mm)</td> </tr> <tr> <td>- trash clearance</td> <td>27 in (686 mm)</td> </tr> <tr> <td>- number of shank rows</td> <td></td> </tr> <tr> <td>  - center</td> <td>3</td> </tr> <tr> <td>  - wings</td> <td>3</td> </tr> <tr> <td>- distance between rows</td> <td></td> </tr> <tr> <td>  - center</td> <td>32 in (813 ram)</td> </tr> <tr> <td>  - wings</td> <td>32 in (813 ram)</td> </tr> <tr> <td>- cross section</td> <td>1.25 x 2 in (32 x 51 mm)</td> </tr> <tr> <td>- stem angle</td> <td>52 degrees</td> </tr> <tr> <td>- sweep hole spacing</td> <td>2.5 in (64 mm)</td> </tr> <tr> <td>- sweep bolt size</td> <td>0.5 in (13 mm)</td> </tr> </table>	- number	25	- lateral spacing	12 in (305 mm)	- trash clearance	27 in (686 mm)	- number of shank rows		- center	3	- wings	3	- distance between rows		- center	32 in (813 ram)	- wings	32 in (813 ram)	- cross section	1.25 x 2 in (32 x 51 mm)	- stem angle	52 degrees	- sweep hole spacing	2.5 in (64 mm)	- sweep bolt size	0.5 in (13 mm)	
- number	25																											
- lateral spacing	12 in (305 mm)																											
- trash clearance	27 in (686 mm)																											
- number of shank rows																												
- center	3																											
- wings	3																											
- distance between rows																												
- center	32 in (813 ram)																											
- wings	32 in (813 ram)																											
- cross section	1.25 x 2 in (32 x 51 mm)																											
- stem angle	52 degrees																											
- sweep hole spacing	2.5 in (64 mm)																											
- sweep bolt size	0.5 in (13 mm)																											
<b>HITCH:</b>	<table border="0"> <tr> <td>- vertical range adjustment</td> <td>Ratchet Jack on A-Frame infinite range</td> </tr> </table>	- vertical range adjustment	Ratchet Jack on A-Frame infinite range																									
- vertical range adjustment	Ratchet Jack on A-Frame infinite range																											
<b>DEPTH CONTROL:</b>	Series Hydraulic																											
<b>FRAME:</b>	<table border="0"> <tr> <td>main cross section</td> <td>4 in (102 mm) square tubing</td> </tr> <tr> <td>wing cross section</td> <td>4 in (102 mm) square tubing</td> </tr> </table>	main cross section	4 in (102 mm) square tubing	wing cross section	4 in (102 mm) square tubing																							
main cross section	4 in (102 mm) square tubing																											
wing cross section	4 in (102 mm) square tubing																											
<b>TIRES:</b>	<table border="0"> <tr> <td>center section</td> <td>Four, 9.5L- 15, 6 ply</td> </tr> <tr> <td>wing sections</td> <td>Two, 9.5L- 15, 6 ply</td> </tr> </table>	center section	Four, 9.5L- 15, 6 ply	wing sections	Two, 9.5L- 15, 6 ply																							
center section	Four, 9.5L- 15, 6 ply																											
wing sections	Two, 9.5L- 15, 6 ply																											
<b>NUMBER OF LUBRICATION POINTS:</b>	<table border="0"> <tr> <td>- grease fittings</td> <td></td> </tr> </table>	- grease fittings																										
- grease fittings																												
<b>HYDRAULIC CYLINDERS:</b>	<table border="0"> <tr> <td>- depth control</td> <td>Four, 3.5 x 12 in (108 x 204 mm)</td> </tr> <tr> <td>- wing lift</td> <td>Two, 3.0 x 24 in (76 x 610 mm)</td> </tr> </table>	- depth control	Four, 3.5 x 12 in (108 x 204 mm)	- wing lift	Two, 3.0 x 24 in (76 x 610 mm)																							
- depth control	Four, 3.5 x 12 in (108 x 204 mm)																											
- wing lift	Two, 3.0 x 24 in (76 x 610 mm)																											
<b>WEIGHTS (without harrows):</b>	<table border="0"> <tr> <td></td> <td><b>FIELD POSITION</b></td> <td><b>TRANSPORT POSITION</b></td> </tr> <tr> <td>- hitch</td> <td>530 lb ( 242 kg)</td> <td>5901b ( 269 kg)</td> </tr> <tr> <td>- right wing</td> <td>810 lb ( 368 kg)</td> <td>----</td> </tr> <tr> <td>- right outside</td> <td>1460 lb ( 664 kg)</td> <td>1830 lb ( 832 kg)</td> </tr> <tr> <td>- right inside</td> <td>850 lb ( 386 kg)</td> <td>1240 lb ( 564 kg)</td> </tr> <tr> <td>- left outside</td> <td>1400 lb ( 636 kg)</td> <td>1860 lb ( 845 kg)</td> </tr> <tr> <td>- left inside</td> <td>840 lb ( 382 kg)</td> <td>1200 lb ( 545 kg)</td> </tr> <tr> <td>- left wing</td> <td>830 lb ( 377 kg)</td> <td>----</td> </tr> <tr> <td>TOTAL</td> <td>6720 lb (3055 kg)</td> <td>6720 lb (3055 kg)</td> </tr> </table>		<b>FIELD POSITION</b>	<b>TRANSPORT POSITION</b>	- hitch	530 lb ( 242 kg)	5901b ( 269 kg)	- right wing	810 lb ( 368 kg)	----	- right outside	1460 lb ( 664 kg)	1830 lb ( 832 kg)	- right inside	850 lb ( 386 kg)	1240 lb ( 564 kg)	- left outside	1400 lb ( 636 kg)	1860 lb ( 845 kg)	- left inside	840 lb ( 382 kg)	1200 lb ( 545 kg)	- left wing	830 lb ( 377 kg)	----	TOTAL	6720 lb (3055 kg)	6720 lb (3055 kg)
	<b>FIELD POSITION</b>	<b>TRANSPORT POSITION</b>																										
- hitch	530 lb ( 242 kg)	5901b ( 269 kg)																										
- right wing	810 lb ( 368 kg)	----																										
- right outside	1460 lb ( 664 kg)	1830 lb ( 832 kg)																										
- right inside	850 lb ( 386 kg)	1240 lb ( 564 kg)																										
- left outside	1400 lb ( 636 kg)	1860 lb ( 845 kg)																										
- left inside	840 lb ( 382 kg)	1200 lb ( 545 kg)																										
- left wing	830 lb ( 377 kg)	----																										
TOTAL	6720 lb (3055 kg)	6720 lb (3055 kg)																										
<b>OPTIONAL EQUIPMENT AVAILABLE:</b>	<ul style="list-style-type: none"> <li>- 4 width options from 25 to 31 ft (7.6 to 9.4 m)</li> <li>- 4.5 to 6 ft (1.4 to 1.8 m) wide three row mounted harrow</li> <li>- 4.5 to 6 ft (1.4 to 1.8 m) wide four row mounted harrow</li> <li>- dual right and left axle assembly for main frame</li> <li>- offset dual right and left axle assembly for main frame</li> <li>- heavy duty kit for hitch</li> <li>- ball type hitch clevis</li> <li>- hammerstrap hitch clevis</li> <li>- 1.25 x 2 in (32 x 51 mm) heavy duty trip assembly</li> <li>- 1.25 x 2 in (32 x 51 mm) rigid shank assembly</li> <li>- heavy duty kit for main and wing frames</li> </ul>																											



**APPENDIX II  
SOIL FORCE TABLES**

The following tables give typical horizontal forces acting on sweeps, spikes, and banding knives located in the front row of a cultivator while operating at different depths in primary and secondary tillage on the prairies. Higher forces may be encountered in extremely heavy, dry or compacted soils.

These values can be used to determine how well the shank assemblies are suited to the various operations. Comparing the sweep pitch curve of the assembly to these soil forces will indicate whether the assembly will hold the soil tool below the acceptable 7 degree sweep pitch.

**TABLE 4.** Forces Required (lb (kN)) in Primary Tillage for Various Soil Tools.

DEPTH in (mm)	SWEEPS			SPIKE	BANDING KNIFE
	FIELD CULT.	HEAVY DUTY CULT.			
	11 in (275 mm)	12 in (305 mm)	16 in (406 mm)	2 in (50 mm)	1 in (25 mm)
	lb (kN)	lb (kN)	lb (kN)	lb (kN)	lb (kN)
2 ( 50)	120 (0.5)	190 (0.8)	220 (1.0)	---	---
3 ( 75)	140 (0.6)	230 (1.0)	280 (1.2)	150 (0.7)	---
4 (100)	180 (0.8)	310 (1.4)	370 (1.6)	190 (0.8)	320 (1.4)
5 (125)	---	420 (1.9)	500 (2.2)	260 (1.2)	390 (1.7)
6 (150)	---	---	---	360 (1.6)	540 (2.4)

**TABLE 5.** Forces Required (lb (kN)) in Secondary Tillage for Various Soil Tools.

DEPTH in (mm)	SWEEPS			SPIKE	BANDING KNIFE
	FIELD CULT.	HEAVY DUTY CULT.			
	11 in (275 mm)	12 in (305 mm)	16 in (406 mm)	2 in (50 mm)	1 in (25 mm)
	lb (kN)	lb (kN)	lb (kN)	lb (kN)	lb (kN)
2 ( 50)	110 (0.5)	170 (0.8)	200 (0.9)	---	---
3 ( 75)	140 (0.6)	220 (1.0)	270 (1.2)	130 (0.6)	---
4 (100)	170 (0.8)	280 (1.2)	340 (1.5)	180 (0.8)	290 (1.3)
5 (125)	---	370 (1.6)	450 (2.0)	290 (1.1)	380 (1.7)
6 (150)	---	---	---	320 (1.4)	490 (2.2)

**APPENDIX III  
POWER REQUIREMENTS**

**Draft Characteristics:** Draft requirements have been measured on several cultivators in various field conditions over the past years. Average draft requirements have been determined from these requirements.

Draft requirements for the same cultivator, in the same field, may vary by as much as 30% in two different years due to changes in soil conditions. Variations in soil conditions affect draft much more than variations in machine make, making it difficult to measure any significant draft differences between make of cultivators.

Since there is little or no draft differences between machines, PAMI has averaged the results obtained over the years and has used these to determine tractor size requirements.

**Recommended Tractor Size:** The following tables show tractor PTO power required to pull cultivators in various conditions at the given depths and speeds. Tractor power requirements have been adjusted to include a tractive efficiency of 80% in primary and 70% in secondary tillage and represent a tractor operating at 80% of maximum PTO power on a level field. These power requirements can be used along with the maximum PTO ratings, as determined by Nebraska tests or as presented by the tractor manufacturer, to select the appropriate tractor. Higher power will be required in hills or in heavy soils. Cultivators with marked differences in spacing, number of rows, or configuration may require more or less power.

Recommended tractor size may be determined by selecting the required horsepower per foot from the appropriate table and multiplying by the width of the cultivator. For example, in primary tillage at 4 in (100 mm) and 5 mph (8 km/h), 6.1 hp/ft (14.9 kW/m) is required. Therefore, for a 25.3 ft (7.7 m) cultivator in those conditions, 150 PTO hp (115 kW) is recommended.

**TABLE 6.** Tractor PTO Power Per Unit Width (hp/ft (kW/m)) Required in Primary Tillage.

DEPTH in (mm)	SPEED - MPH (km/h)		
	4.0 ( 6.4)	5.0 ( 8.0)	6.0 ( 9.7)
2 ( 50)	2.7 ( 6.6)	3.4 ( 8.3)	4.1 (10.0)
3 ( 75)	3.8 ( 9.3)	4.8 (11.7)	5.8 (14.2)
4 (100)	4.9 (12.0)	6.1 (14.9)	7.4 (18.1)
5 (125)	6.0 (14.7)	7.5 (18.4)	9.0 (22.0)

**TABLE 7.** Tractor PTO Power Per Unit Width (hp/ft (kW/m)) Required in Secondary Tillage.

DEPTH in (mm)	SPEED - MPH (km/h)		
	4.0 ( 6.4)	5.0 ( 8.0)	6.0 ( 9.7)
2 ( 50)	2.3 ( 5.6)	3.0 ( 7.3)	3.6 ( 8.8)
3 ( 75)	3.4 ( 8.3)	4.3 (10.5)	5.2 (12.7)
4 (100)	4.5 (11.0)	5.6 (13.7)	6.8 (16.6)
5 (125)	5.5 (13.5)	7.0 (17.1)	8.4 (20.6)

**APPENDIX IV  
MACHINE RATINGS**

The following rating scale is used in PAMI Evaluation Reports:

- Excellent
- Very Good
- Good
- Fair
- Poor
- Unsatisfactory

# SUMMARY CHART

## MORRIS MAGNUM II CP-725 CHISEL PLOW

<b>RETAIL PRICE:</b>	\$17,582.00 (July, 1988 f.o.b. Lethbridge 25.3 ft (7.7 m) width, complete with duals on main frame and 4-bar mounted harrows.)
<b>QUALITY OF WORK:</b>	
Penetration	<b>Very Good.</b>
Depth Uniformity	<b>Very Good;</b> level furrow bottom in pri- mary and secondary conditions.
Stone Protection	<b>Very Good;</b> trip height was 10 in (254 mm)
Trash Clearance	<b>Very Good.</b>
Surface Finish	<b>Good;</b> in light to moderate trash condition harrows were effective.
Skewing and Stability	Stable.
<b>EASE OF OPERATION AND ADJUSTMENT:</b>	
Maintenance	<b>Good;</b> maintenance schedule was vague.
Transporting	<b>Very Good;</b> easy to put in transport position and to maneuver.
Frame Levelling	<b>Very Good.</b>
Depth Adjustment	<b>Very Good;</b> easily changed
Harrow Adjustment	<b>Good.</b>
<b>POWER REQUIREMENTS:</b>	
Secondary Tillage	109 hp (81 kW) at 3 in (75 mm) and 5 mph (8 km/h)
Primary Tillage	121 hp (91 kW) at 3 in (75 mm) and 5 mph (8 km/h)
<b>OPERATOR SAFETY:</b>	Safe if normal precautions observed.
<b>OPERATOR'S MANUAL:</b>	<b>Good;</b> contained useful information.
<b>MECHANICAL HISTORY:</b>	Few minor problems occurred during the evaluation.



**ALBERTA  
FARM  
MACHINERY  
RESEARCH  
CENTRE**

3000 College Drive South  
Lethbridge, Alberta, Canada T1K 1L6  
Telephone: (403) 329-1212  
FAX: (403) 329-5562  
<http://www.agric.gov.ab.ca/navigation/engineering/afmrc/index.html>

### Prairie Agricultural Machinery Institute

Head Office: P.O. Box 1900, Humboldt, Saskatchewan, Canada S0K 2A0  
Telephone: (306) 682-2555

**Test Stations:**

P.O. Box 1060

Portage la Prairie, Manitoba, Canada R1N 3C5

Telephone: (204) 239-5445

Fax: (204) 239-7124

P.O. Box 1150

Humboldt, Saskatchewan, Canada S0K 2A0

Telephone: (306) 682-5033

Fax: (306) 682-5080