

# Evaluation Report 60

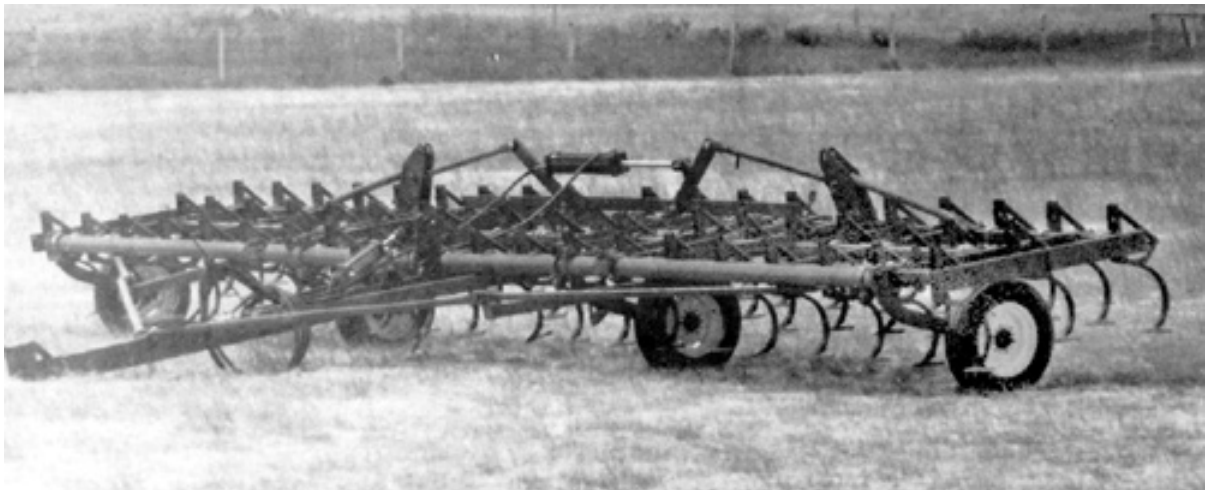

## White 485 Field Cultivator

A Co-operative Program Between



# WHITE 485 FIELD CULTIVATOR

## MANUFACTURER:

White Farm Equipment Company  
White Motor Corporation of Canada Limited  
148 Mohawk Street  
Brantford, Ontario  
N3T 5R7

## DISTRIBUTOR:

White Farm Equipment  
2201 - 1st Avenue  
Regina, Saskatchewan  
S4P 3A3

## RETAIL PRICE:

\$7,220.00 (April, 1979, f.o.b. Lethbridge, 9.7 m width)

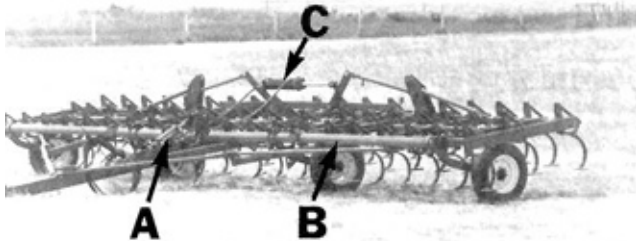

FIGURE 1. White 485: (A) Depth Control Cylinder, (B) Rockshaft, (C) Wing Lift Cylinder.

## SUMMARY AND CONCLUSIONS

Overall functional performance of the White 485 field cultivator was good for seedbed preparation and herbicide incorporation, providing mounted finishing harrows were used. Its performance for second operation summerfallow was fair with acceptable weed kill if 203 mm (8 in) sweeps, or larger, were used and if trash conditions were light. The White 485 was unsuitable for first operation summerfallow or in moderate trash.

The spring cushioned shanks could lift 178 mm (7 in) to clear stones. As with most field cultivators, the shanks were very flexible. When equipped with recommended sweeps, having a 40 degree stem angle, sweep pitch varied from 0 degrees to 12 degrees over the range of normal secondary tillage draft, resulting in furrow bottom ridging in firm soils. With 165 mm (6.5 in) shank spacing, shank cushioning spring preload was exceeded at drafts greater than 1.6 kN/m (110 lb/ft), occurring midway within the secondary tillage draft range. Penetration was adequate in previously tilled soil, but inadequate in harder soils. Plugging was a problem in medium to heavy trash. The White 485 buried less trash than most heavy duty cultivators. The sweep pattern was symmetrical and sideways skewing was not a problem in normal field conditions. Slight skewing occurred on hillsides. Weed kill in second operation summerfallow was good with 203 mm sweeps, providing the weeds were small and shallow rooted.

The White 485 could be conveniently placed into transport position in less than five minutes. The 160 mm (6.25 in) sweep-to-ground clearance, in transport position, was usually adequate. Due to its large transport width and height, transporting on public roads had to be with extreme caution. Although the White 485 towed well at speeds up to 32 km/h (20 mph), this was unsafe, since the tire loads in transport position exceeded the Tire and Rim Association maximum rating by 84%.

The 9.7 m (31.9 ft) wide test machine had a transport height of 3.8 m (12.3 ft) permitting safe transport under power lines in the three prairie provinces.

No hitch jack was provided. Adequate adjustment was provided for both lateral and fore-and-aft levelling. Tillage depth was uniform across the width of the cultivator in all conditions, except when

cultivating over hill crests. The wing lift linkage limited downward wing flexibility.

Average draft for the 9.7 m (31.9 ft) wide test machine, in light secondary tillage, at 8 km/h (5 mph), varied from 8 kN (1760 lb) at 40 mm (1.5 in) depth to 19 kN (4180 lb) at 100 mm (4 in) depth. In heavy secondary tillage, at 8 km/h (5 mph), average draft varied from 14 kN (3080 lb) at 40 mm (1.5 in) to 29 kN (6380 lb) at 100 mm (4 in).

In light secondary tillage, at 10 km/h (6.2 mph) and 75 mm (3 in) depth, a tractor with 81 kW (109 hp) maximum power take-off rating will have sufficient power reserve to operate a 9.7 m (31.9 ft) wide White 485. In heavy secondary tillage at the same depth and speed, a 117 kW (157 hp) tractor is needed.

The White 485 was equipped with wing and depth control cylinder transport locks, to aid in transport safety. A slow moving vehicle sign was not supplied. The operator's manual was concise and well illustrated but lacked information on the hydraulic wing lift system.

Some minor mechanical problems occurred during the 197 hours of field operation: One wheel rim loosened and was damaged, while a few assorted bolts and clamps loosened.

## RECOMMENDATIONS

It is recommended that the manufacturer consider:

1. Equipping the cultivator with tires that do not exceed the Tire and Rim Association maximum rating.
2. Modifying the wing lift linkage to eliminate momentary drop and to reduce forces during initial lowering, as well as to increase downward wing flexibility in field position.
3. Providing a hitch jack to facilitate hitching.
4. Supplying mounted finishing harrows as an option.
5. Providing some means of holding the hitch link in the horizontal position to facilitate one-man hitching.
6. Working with the agricultural equipment industry to standardize hydraulic quick couplers and hydraulic hose fitting threads.
7. Working with the agricultural equipment industry to standardize shank and sweep stem angles, and sweep fastener spacings and sizes.

Chief Engineer- E. O. Nyborg

Senior Engineer - E. H. Wiens

## THE MANUFACTURER STATES THAT

With regard to recommendation number:

1. To date, we have experienced no problems with the wheels offered on this machine. We have found the loads as shown by the Tire and Rim Association to be very conservative. We do offer as an option a 20" wheel for the 485.
2. The wing linkage is designed so positive control is maintained throughout raising and lowering cycles. We will check to see if we have lost this control through manufacturing tolerances throughout the years.  
The wing flexibility has been designed purposely to restrict up and down wing movement to 5 or 6 degrees to keep the sweeps from interfering with the tires.
3. We provide a hitch jack as an attachment. We normally let the market dictate whether some attachments should be regular equipment or not.
4. We have elected to let specialists supply finishing harrows as attachments since our volume would be limited.
5. We have relied on the tractor swinging drawbar to facilitate hook up to an implement clevis.
- 6 & 7. Our company has personnel involved with Standards Committees for ASAE and FIEI.

## GENERAL DESCRIPTION

The White 485 is a trailing, flexible, three-section field cultivator suitable for light tillage such as seedbed preparation, herbicide incorporation and secondary summerfallow. It is available in eight widths ranging from 7.8 to 10.4 m. The test machine was a 9.7 m model, with a 3.9 m centre frame and two 2.9 m wings. It was equipped with 59 spring cushioned shanks, laterally spaced at 165 mm, arranged in three rows.

The centre frame is carried on two wheels, while each wing is supported by a single wheel. Tillage depth is set with a single hydraulic cylinder, controlling a rockshaft for both the centre section and wing wheels. The wings fold into upright transport position with a single hydraulic cylinder. A tractor with dual remote hydraulic controls is needed to operate the White 485.

Detailed specifications are given in APPENDIX I while FIGURE 1 shows the location of major components.

## SCOPE OF TEST

The White 485 was operated in the field conditions shown in TABLE 1, for 197 hours, while cultivating about 1696 ha. It was evaluated for quality of work, ease of operation and adjustment, power requirements, safety and suitability of the operator's manual.

Mounted finishing harrows were not available from the cultivator manufacturer. Ajax mounted harrows were used during part of the test.

TABLE 1. Operating Conditions

FIELD CONDITION	HOURS	FIELD AREA (ha)
Soil Type		
- loam	53	456
- clay loam	92	792
- clay	52	448
<b>Total</b>	<b>197</b>	<b>1 696</b>
Stony Phase		
- stone free	110	947
- occasional stones	42	362
- moderately stony	45	387
- very stony	0	0
<b>Total</b>	<b>197</b>	<b>1 696</b>

## RESULTS AND DISCUSSION

### QUALITY OF WORK

**Shank Characteristics:** There is a large variation in shank and sweep stem angles (FIGURE 2) on cultivators from different manufacturers. Sweeps and shanks must be matched to obtain sufficient sweep pitch to achieve and maintain penetration. Usually manufacturers recommend sweeps with a stem angle from 0 to 5 degrees less than the shank stem angle to result in a slightly positive no-load sweep pitch.

Sweep pitch increases in proportion to draft due to shank flexing and, depending on shank stiffness and cushioning spring preload, may become excessive in normal tillage, on some cultivators. A slightly positive sweep pitch results in uniform tillage depth and a smooth furrow bottom while excessive sweep pitch causes furrow bottom ridging and rapid sweep tip wear. Shanks which maintain a relatively constant sweep pitch, over the normal range of tillage forces, are desirable.

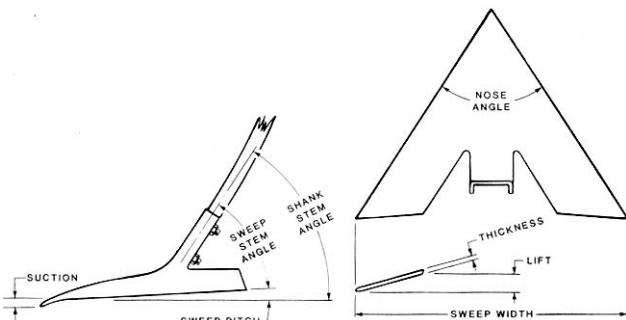

FIGURE 2. Shank and Sweep Terminology.

The White 485 was equipped with adjustable, spring cushioned shank holders. The spring holder tubes could be set in two positions to suit soil conditions. The normal position was recommended for mellow soils in typical secondary tillage, while the alternate position was intended to aid penetration in harder soils. The shanks consisted of two curved leaf springs. Sweeps bolted to the forward spring leaves while the rear leaves were joined to the sweeps by means of spacers on the upper sweep bolts. This arrangement permitted relative movement of the two leaf springs on each shank. During most of the test, the White 485 was used with 203 mm wide White sweeps with a 40 degree stem angle, giving a no-load sweep pitch of 0 degrees.

FIGURE 3 shows pitch characteristics of the White 485 shank assembly. The low end of the pitch curve results from shank flexing, while the steeper upper part of the curve occurs when draft is large enough to overcome cushioning spring preload. Sweep pitch varied 12 degrees over the full range of draft normally occurring in secondary tillage. When equipped with 40 degree sweeps, as used during the test, sweep pitch varied from 0 to 12 degrees over this draft range. Cushioning spring preload was exceeded at drafts greater than 1.6 kN/m, occurring midway in the range of normal secondary tillage drafts. This shows that the White 485 is suitable only for light, secondary tillage and is unsuitable for heavier tillage operations. Setting the spring holder tubes in the alternate position, as recommended for harder soils, was of little benefit at higher drafts, since it only increased initial sweep pitch from 0 to 6 degrees.

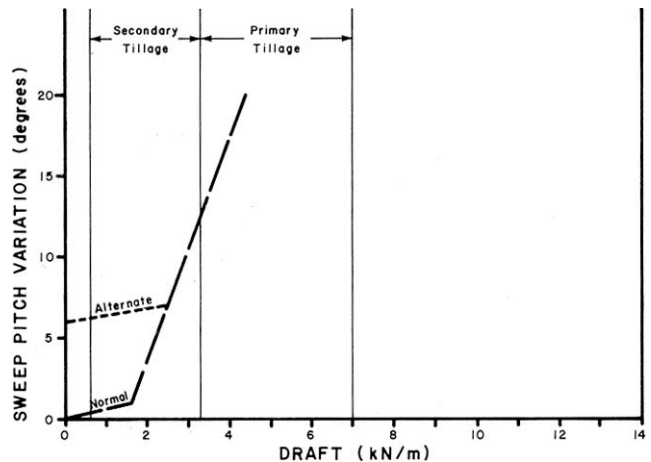

FIGURE 3. Sweep Pitch Variation over a Normal Range of Draft (165 mm shank spacing)

Figure 4 shows the lifting pattern when shanks encounter stones or field obstructions. Maximum lift height was 178 mm with the spring holder tube in either position. The shank assemblies performed well throughout the test. No shanks or sweep damage occurred.

**Penetration:** Penetration was good in light tillage, such as seedbed preparation, herbicide incorporation and secondary summerfallow. Penetration was inadequate in harder soils and in primary tillage operations. As with most field cultivators, the White 485 was not intended for primary tillage.

Penetration was uniform across the cultivator width. Although no flotation problems occurred during the test, the centre wheels carried considerably more weight than the wing wheels and sinking of the centre section could be expected in very soft, wet fields. Each centre section wheel supported about 37% of the cultivator weight while each wing wheel supported about 13%. In addition, each centre section wheel supported, about 33% of the total tillage suction force while each wing wheel supported about 17%. For good flotation, it is desirable to have wheels sized and positioned so that each supports equivalent weight and a similar tillage force.

Depth differences between the front and rear rows of shanks were slight, once the frame had been properly levelled. In normal secondary tillage, the frame remained relatively level with little twisting of the wing frames.

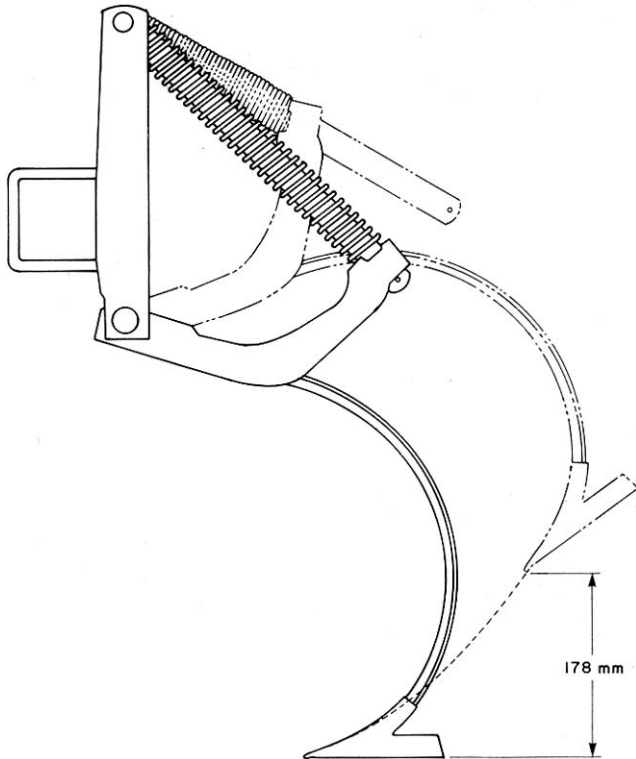

FIGURE 4. Shank Lifting Pattern (Spring Holder Tube in Normal Position).

In hilly fields, lack of wing flexibility caused insufficient wing penetration, when cultivating over the crests of sharp hills. This was caused by limitations in the wing lift linkage. The lift linkage, in field position, had insufficient travel to permit the wings to pivot downward in relation to the centre frame, causing the wing sweeps to come out of the ground over sharp hill crests (FIGURE 5). It is



FIGURE 5. Wing Lift Linkage Preventing Wings Pivoting Downward in Relation to Centre Frame.

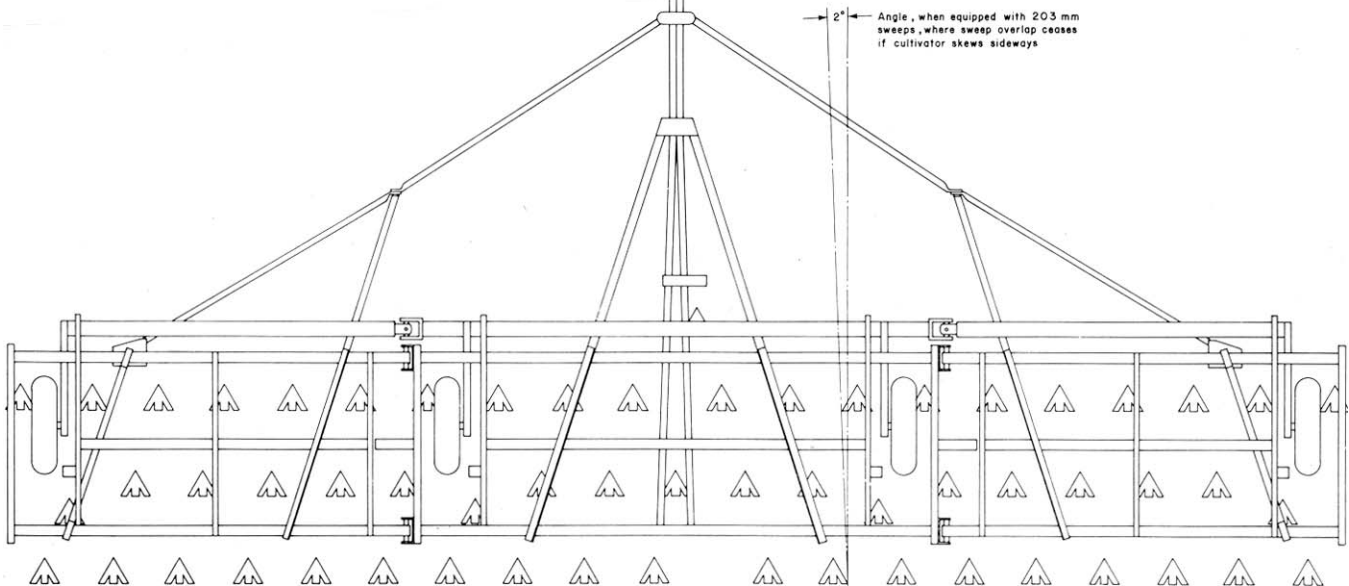

FIGURE 8. Sweep Pattern (165 mm shank spacing).

recommended that the wing lift linkage be modified to permit greater downward wing flexibility. The White 485 followed the contour well through field depressions (FIGURE 6), providing that the wing lift cylinder was positioned to prevent interference with wing lift free travel.

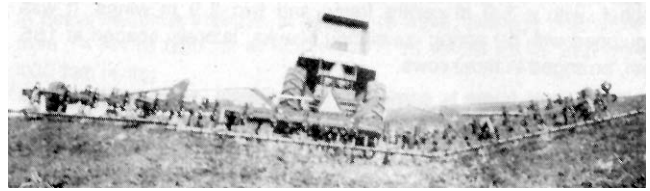

FIGURE 6. Ample Wing Flexibility when Pivoting Upward in Relation to Centre Frame.

**Plugging:** No plugging occurred in very light trash and light weed growth. In heavier trash the White 485 plugged frequently across the entire machine width (FIGURE 7). Plugging usually began at the front row on the wing sections and spread quickly across the entire cultivator width. Plugging restricted use of the White 485 to chemical incorporation or seedbed preparation in light trash conditions.



FIGURE 7. Plugging in Moderate to Heavy Trash.

**Trash Burial and Field Surface:** The White 485 buried less trash than most heavy duty cultivators. In light, secondary tillage, the resulting soil surface was relatively smooth, even and unridged. Mounted finishing harrows aided in smoothing the soil surface to produce a very uniform seedbed.

**Furrow Bottom Ridging:** In soft, previously tilled fields, furrow bottom ridging was less than 10 mm. In fields with a hard subsoil layer, ridging was severe due to excessive sweep pitch (FIGURE 3) at high draft.

**Skewing and Stability:** The White 485 was very stable and did not skew sideways in normal field conditions. The shank pattern (FIGURE 8) was symmetrical and did not impose any side forces on the cultivator during normal tillage. As with most field cultivators, slight skewing occurred on hillsides. When equipped with 203 mm sweeps, weeds were missed if the cultivator skewed more than 2 degrees (FIGURE 8).

**Weed Kill:** Weed kill was good with 203 mm sweeps in small, shallow rooted weeds. In heavy stalked or well-rooted weeds, many weeds were not completely uprooted. Many larger weeds were missed due to the lateral movement of the shanks in the shank holders. With 203 mm sweeps, the White 485 should be used only in small, light stalked, shallow rooted weeds.

**EASE OF OPERATION AND ADJUSTMENT**

**Transporting:** The White 485 was easily placed in transport position (FIGURE 9) using the hydraulic wing lift system supplied as standard equipment. Two pins, which had to be inserted by hand, were provided to lock the wings during transport. A mechanical transport lock was also supplied for the depth control cylinder. Raising or lowering, which depended on the tractor hydraulic system, took one man less than five minutes.

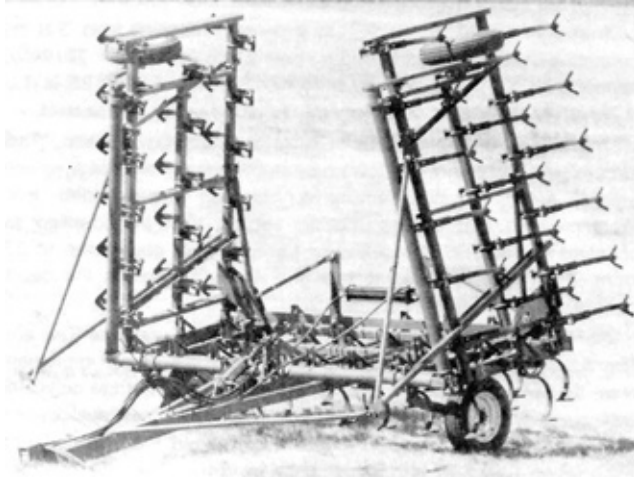

FIGURE 9. Transport Position.

Slots in the wing lift brackets (FIGURE 10) allowed the wings to momentarily drop, as they went over centre, when being lowered to field position. This placed a shock load on the wing lift cylinder, hoses and linkages. The geometry of the lift linkage was such that, during initial lowering, a high force was needed to push the wings over centre, especially if the wings were lowered on a side slope. It is recommended that the wing lift linkage be modified to eliminate the momentary drop and to reduce forces during initial lowering.

Transport width was 5 m while transport height was 3.8 m. Extreme care was needed when transporting on public roads, through gates, over bridges and beneath power or telephone lines. The White 485 towed well at transport speeds up to 32 km/h.

Sweep to ground clearance during transport was 160 mm, while transport wheel tread was 3.3 m. This usually provided ample ground clearance.

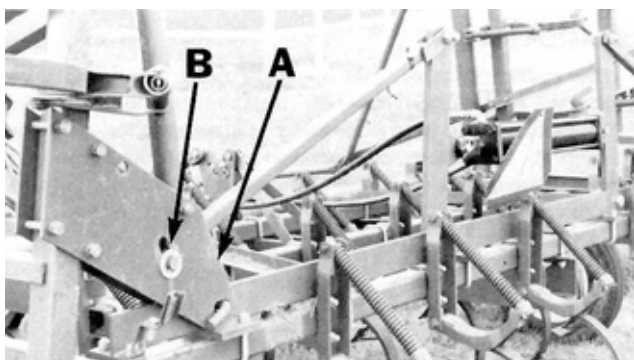

FIGURE 10. Wing Lift Linkage: (A) Wing Lift Bracket, (B) Slot.

**Hitching:** The hitch weight of the White 485, without mounted harrows, was 116 kg in transport and 70 kg in field position. Hitching was difficult as no hitch jack was supplied. It is recommended a hitch jack be supplied to facilitate hitching.

The hitch link swivelled downward when not hitched to a tractor (FIGURE 11). One-man hitching would have been greatly facilitated if the link remained horizontal.

Hitch height could be adjusted 185 mm in five increments by removing one bolt. This range was adequate to allow fore-and-aft cultivator frame levelling with all tractors used during testing.

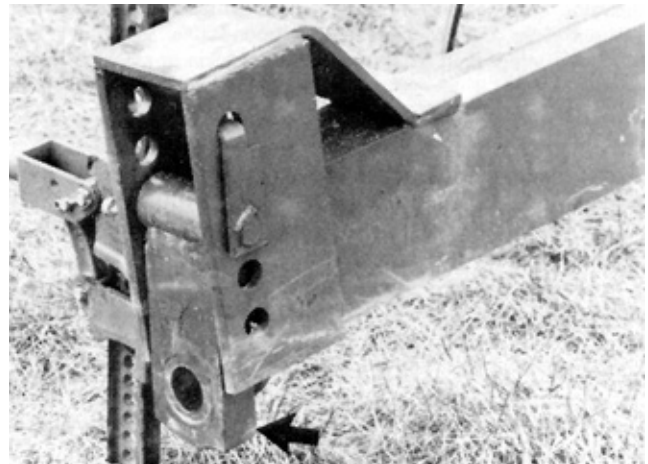

FIGURE 11. Hitch Link in Vertical Position.

**Frame Levelling:** Adequate lateral levelling adjustments were provided for both the centre and wing sections. The centre frame was levelled by positioning the rockshaft in relation to the right wheel, using the slots provided. The wings were levelled with adjustable stops at the outer ends of the wing rockshafts.

**Depth of Tillage:** Tillage depth was controlled with one hydraulic cylinder attached at the centre of the rockshaft. A depth stop consisting of a threaded sleeve, provided depth adjustment. This adjustment was easy to use, as no tools were needed. With the cultivator frame levelled, depth of tillage across the cultivator was uniform. As discussed previously, the wing lift linkage restricted wing penetration over the crests of hills.

**Sweep Installation:** It took one man about three hours to remove and replace the 59 sweeps on the White 485. The sweep bolts were short enough to have their ends completely covered by the retaining nuts, preventing thread damage to the sweep bolts during tillage.

All sweeps adjacent to the wheels had to have one wing cut off (FIGURE 12) to prevent tire interference and damage. This was inconvenient since an acetylene torch was needed when changing sweeps.



FIGURE 12. Sweep Wing Cut Off to Prevent Tire Damage.

**Shank Installation:** Shanks could be easily replaced by removing one bolt. A shank could be replaced in less than five minutes.

## POWER REQUIREMENTS

**Draft Characteristics:** FIGURE 13 shows draft requirements for field cultivators in typical secondary tillage, at a speed of 8 km/h. This figure gives average requirements based on tests of six makes of field cultivators in two seasons and 12 different field conditions. Attempting to compare draft requirements of different makes of field cultivators usually is unrealistic. Draft requirements for the same cultivator, in the same field, may vary by as much as 30% in two different years, due to changes in soil conditions. Variation in soil conditions affect draft much more than variation in machine make, usually making it impossible to measure any significant draft differences between different makes of field cultivators.

In light secondary tillage, such as herbicide incorporation or seedbed preparation, average draft per metre of width, at 8 km/h, varied from 0.8 kN at 40 mm depth to 2 kN at 100 mm depth. For the 9.7 m wide test machine, this corresponds to a total draft ranging from about 8 to 19 kN.

In heavy secondary tillage, such as firm summerfallow, average draft per metre of width, at 8 km/h, varied from 1.4 kN at 40 mm depth to 3 kN at 100 mm depth, corresponding to a total variation from about 14 to 29 kN for the 9.7 m test machine.

Increasing speed by 1 km/h, increased draft by about 90 N per metre of width. For the 9.7 m wide test machine this represents a draft increase of 0.9 kN for the 1 km/h speed increase.

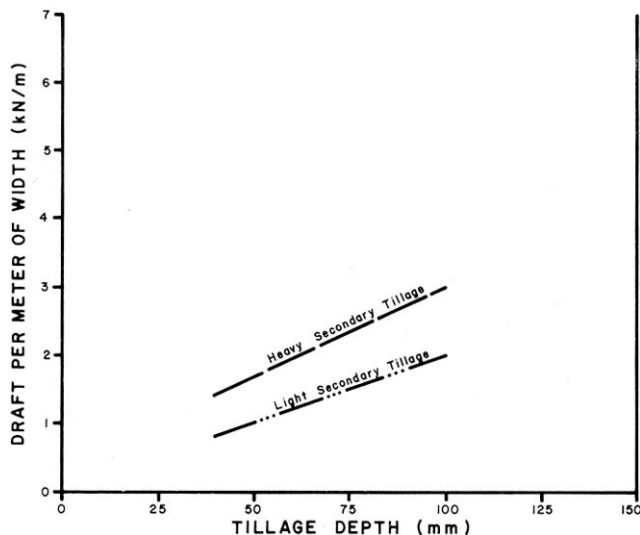

FIGURE 13. Average Draft Requirements for Field Cultivators at 8 km/h.

**Tractor Size:** TABLES 2 and 3 show tractor sizes needed to operate the 9.7 m wide White 485 in light and heavy secondary tillage. Tractor sizes have been adjusted to include tractive efficiency in loose soils and represent a tractor operating at 80% of maximum power on a level field. The sizes presented in the tables are the maximum power take-off rating, as determined by Nebraska tests or as presented by the tractor manufacturer. Selected tractor sizes will have ample power reserve to operate the White 485 in the stated conditions.

Tractor size may be determined by selecting the desired tillage depth and speed from the appropriate table. For example, in light secondary tillage at 75 mm depth and 10 km/h, an 81 kW tractor is needed to operate the White 485. In heavy secondary tillage at the same depth and speed, a 117 kW tractor is needed.

TABLE 2. Tractor Size (Maximum Power Take-off Rating, kW) to Operate the 9.7 m Wide White 485 in Light Secondary Tillage.

DEPTH (mm)	SPEED (km/h)					
	7	8	9	10	11	12
40	23	29	37	45	53	63
50	30	38	46	55	65	75
75	48	58	69	81	93	106
100	66	79	92	106	121	137

TABLE 3. Tractor Size (Maximum Power Take-off Rating, kW) to Operate the 9.7 m Wide White 485 in Heavy Secondary Tillage.

DEPTH (mm)	SPEED (km/h)					
	7	8	9	10	11	12
40	42	51	62	73	85	98
50	51	61	73	86	99	113
75	73	87	101	117	134	151
100	95	112	130	149	168	189

## OPERATOR SAFETY

Extreme caution is needed in transporting most folding cultivators, to avoid contacting power lines. Minimum power line heights vary in the three prairie provinces. In Saskatchewan, the energized line may be as low as 5.2 m over farm land or over secondary roads. In Alberta and Manitoba, the neutral ground wire may be as low as 4.8 m over farm land. In all three provinces, feeder lines in farmyards may be as low as 4.6 m.

Transport height of the 9.7 m wide test machine was 3.8 m, permitting safe transport under prairie power lines. Similarly, transport height of the 10.4 m wide model of the White 485 is 4.2 m, which is also low enough for safe transport under power lines.

The White 485 was 5.0 m wide in transport position. This necessitated caution when towing on public roads, over bridges and through gates. No slow moving vehicle sign was provided. It is recommended that a slow moving vehicle sign be supplied as standard equipment. The cultivator towed well at speeds up to 32 km/h. Pins were provided to lock the wings as well as the depth control cylinder in transport position.

Centre frame tire loads in field position, exceeded the Tire and Rim Association maximum rating, for 6.70 x 15, 4-ply implement tires, by 38%. In transport position the entire weight of the cultivator was supported by the two main frame wheels. Individual centre frame tire loads, in transport position, exceeded the Tire and Rim Association Standard maximum rating by 84%. This tire overdoad was considered unsafe and extremely hazardous, especially at high transport speeds. It is recommended that the cultivator be equipped with tires that do not exceed the Tire and Rim Association maximum rating.

The operator's manual clearly outlined all safety precautions.

## STANDARDIZATION

**Hydraulics:** During the test, considerable difficulty was encountered due to differences in hydraulic couplers on various tractors. The difficulty was in the lack of standardization both in couplers and in hose threads. More standardization is needed in this area.

**Sweep Bolt Holes:** The bolt hole size and spacing on cultivator sweeps and shanks, as well as stem angles, should similarly be standardized to provide some degree of interchangeability of sweeps.

## OPERATOR'S MANUAL

The operator's manual was generally good, containing useful information on operation, assembly, maintenance and safety. Most of the discussion on wing lift operation, pertained to the cable wing lift system. Instructions on operation of the hydraulic wing lift system were sketchy. Further discussion is needed to clarify operation of both wing lift options. The manual was generally clear and well illustrated.

## DURABILITY RESULTS

TABLE 4 outlines the mechanical history of the White 485 during 197 hours of field operation while tilling about 1696 ha. The intent of the test was evaluation of functional performance. The following mechanical problems represent those which occurred during the functional testing: An extended durability evaluation was not conducted.

TABLE 4. Mechanical History

ITEM	OPERATING	EQUIVALENT FIELD AREA ha
<b>Wheels</b>		
- The left centre wheel bolts loosened, damaging the rim, necessitating replacement at	42	362
<b>Shanks and Sweeps</b>		
- Two shank clamps loosened and were tightened at	75	646
- The sweeps were replaced at	140	1205
- A shank pivot nut fell off allowing the bolt to pull out, bending the shank holder at	197	1696
<b>Frame</b>		
- Bolts securing the centre section hitch braces loosened and were tightened at	152	1309
- A rockshaft wheel support arm bolt was lost and replaced at	180	1550

## DISCUSSION OF MECHANICAL PROBLEMS

**Wheels:** The wheel bolts on the left centre section wheel loosened, probably due to a combination of wheel overload during transport and improper torquing during assembly. Although no further loosening occurred, since the centre section tires were overloaded 84% in transport position, this may be a problem area.

**Sweeps:** The sweeps needed replacement after 140 hours. Sweep wear rate depends on the type and abrasiveness of the soil. Great variation can be expected.

## APPENDIX I

### SPECIFICATIONS

**MAKE:** White Field Cultivator  
**MODEL:** 485 (9.7 m size)  
**MANUFACTURER:** White Farm Equipment Company  
 148 Mohawk Street  
 Brantford, Ontsrid  
 N3T 5R7

	FIELD POSITION	TRANSPORT POSITION
<b>Dimensions:</b>		
- width	9735 mm	5020 mm
- length	5015 mm	5015 mm
- height	1090 mm	3750 mm
- maximum ground clearance	160 mm	160 mm
- wheel tread	9250 mm	3315 mm

<b>Shanks:</b>		
- number	59	
- lateral spacing	165 mm	
- trash clearance (frame to sweep tip)	505 mm	
- number of shank rows:		
- centre section	3	
- wings	3	
- distance between rows	630 mm	
- shank cross section	19 x 44 mm	
- shank stem angle	40°	

<b>Hitch:</b>		
- vertical adjustment range	185 mm	
<b>Depth Control:</b>		
	hydraulic	

<b>Frame:</b>		
- cross section	76 mm square tubing	

<b>Tires:</b>		
- centre section	2, 6.70 x 15, 4 ply	
- wings	2, 6.70 x 15, 4 ply	
<b>Number of Lubrication Points:</b>		
	6 grease fittings, 10 hour service	
	4 wheel bearings, annual service	

<b>Hydraulic Cylinders:</b>		
- main frame, depth control	1, 89 x 203 mm	
- wing lift cylinder	1, 102 x 610 mm	

	FIELD POSITION	TRANSPORT POSITION
<b>Weights: (Without Harrows)</b>		
- right wheel	282 kg	
- right centre wheel	824 kg	1083 kg
- left centre wheel	824 kg	1083 kg
- left wheel	282 kg	
- hitch	70 kg	116 kg
<b>TOTAL</b>	<b>2282 kg</b>	<b>2282 kg</b>

**Optional Equipment:**  
 - eight width options from 7.8 to 10.4 m

## APPENDIX II

### MACHINE RATINGS

The following rating scale is used in PAMI Evaluation Reports:

(a) excellent	(d) fair
(b) very good	(e) poor
(c) good	(f) unsatisfactory

## APPENDIX III

### METRIC UNITS

In keeping with the Canadian Metric Conversion program this report has been prepared in SI units. For comparative purposes, the following conversions may be used:

1 hectare (ha)	= 2.47 acres (ac)
1 kilometre/hour (kin/h)	= 0.62 mile/hour (mph)
1000 millimetres (mm) = 1 metre (m)	= 39.37 inches (in)
1 kilowatt (kW)	= 1.34 horsepower (hp)
1 kilogram (kg)	= 2.20 pounds mass (lb)
1 newton (N)	= 0.22 pounds force (lb)
1 kilonewton (kN)	= 220 pounds force (lb)
1 kilonewton/metre (kN/m)	= 70 pounds force/foot (lb/ft)



**ALBERTA  
 FARM  
 MACHINERY  
 RESEARCH  
 CENTRE**

3000 College Drive South  
 Lethbridge, Alberta, Canada T1K 1L6  
 Telephone: (403) 329-1212  
 FAX: (403) 329-5562

<http://www.agric.gov.ab.ca/navigation/engineering/afmrc/index.html>

## Prairie Agricultural Machinery Institute

Head Office: P.O. Box 1900, Humboldt, Saskatchewan, Canada S0K 2A0  
 Telephone: (306) 682-2555

Test Stations:  
 P.O. Box 1060  
 Portage la Prairie, Manitoba, Canada R1N 3C5  
 Telephone: (204) 239-5445  
 Fax: (204) 239-7124

P.O. Box 1150  
 Humboldt, Saskatchewan, Canada S0K 2A0  
 Telephone: (306) 682-5033  
 Fax: (306) 682-5080