

February 1997
Tested at Lethbridge
AFMRC File EL0795A
ISSN 0383-3445
Group 10 (d)

Evaluation Report 728

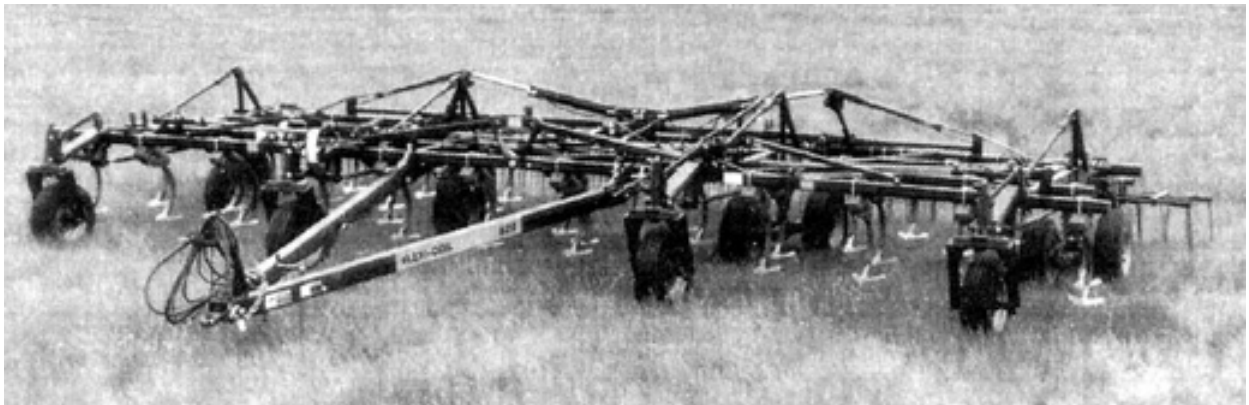

Flexi-coil 820 Floating Hitch Cultivator

A Co-operative Program Between



ALBERTA
FARM
MACHINERY
RESEARCH
CENTRE



PRAIRIE AGRICULTURAL MACHINERY INSTITUTE

FLEXI-COIL 820 FLOATING HITCH CULTIVATOR

MANUFACTURER AND DISTRIBUTOR:

Flexi-coil Ltd.
1000 71 Street East
P.O. Box 1928
Saskatoon, SK. S7K 3S5
Phone: 306/934-3500

RETAIL PRICE:

\$40,186.50 (February 1997, f.o.b. Lethbridge, Alberta) for 33 ft (10.0 m) wide cultivator complete with 45 - 550 lb shank trips spaced at 9 in (229 mm), 11 in (279 mm) Nok-On sweeps, 3 in (76 mm) Nok-On spoons, mounted packer/harrow option, mounting wedges and 3 bar mounted harrows.

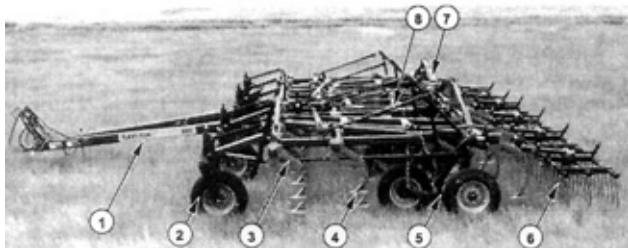

Figure 1. Flexi-coil 820 Floating Hitch Cultivator: (1) Floating Hitch, (2) Gauge Wheel, (3) 550 lb Shank Trip, (4) Nok-On Sweep, (5) Dual Axle Wheel Set, (6) Mounted Harrows, (7) Wing Lift Cylinders and (8) Depth Control Cylinder.

SUMMARY

QUALITY OF WORK

The Flexi-coil 820 floating hitch cultivator was suitable for primary and secondary tillage. Penetration was similar for both the 11 in (279 mm) Nok-On sweeps and 3 in (76 mm) Nok-On spoons. Uneven penetration resulted when working in dry, hard primary tillage. Depth uniformity of the Flexi-coil 820 floating hitch cultivator was very good in secondary and moist primary conditions. Uniformity was reduced when working in dry, hard primary conditions or in sharply rolling terrain. The shank trip mechanism maintained uniform tillage depth at horizontal forces up to 543 lb (2.4 kN) where the shank began to trip as the spring-trip preload was overcome.

The maximum lift height of the shank assembly was 11 in (279 mm) when equipped with 11 in (279 mm) Nok-On sweeps or 3 in (76 mm) Nok-On spoons. The lift height provided very good stone protection.

The 4 row, 30 in (762 mm) sweep-to-frame clearance and 9 in (229 mm) shank spacing allowed for good residue flow. The 9 in (229 mm) sweep pattern required shanks be mounted behind the front tire of the dual axle wheel sets, reducing the clearance between the walking beam and shank. Plugging usually occurred at the walking beam locations when working in moist soil conditions with heavy trash. Occasional plugging also occurred at the centre of the unit due to the narrow lateral spacing between shanks.

In primary tillage, with the mounted harrows set at a less aggressive working angle soil ridging occurred, with the majority of the straw remaining on the surface. Using a more aggressive harrow angle reduced the soil ridging, producing a uniform seedbed with less straw remaining on the surface.

The Flexi-coil 820 was stable and did not skew sideways in typical field conditions. The symmetrical sweep pattern required skewing greater than 2° before tillage misses occurred.

EASE OF OPERATION AND ADJUSTMENT

Maintenance of the cultivator was very good, with easy access to all lubrication points. One person could replace the 45 Nok-On

sweeps or spoons in 20 minutes. Ease of hitching was very good. A safety chain was supplied as standard equipment

Transporting the 820 cultivator was very good. The cultivator was placed into transport, position in 5 minutes. The over-centred position of the wings in transport eliminated the need for a mechanical safety lock. Ease of levelling the frame was good. Level ground was required for initial frame levelling.

Ease of setting the tillage depth was very good. Tillage depth was changed by repositioning the depth stop adjustor assembly on the depth stop rod. Ease of adjusting the optional tine harrows was good. Harrow tine angle was selected from 1 of the 6 available detents. Harrow downward pressure was adjusted by the location of the top pin and spring length.

POWER REQUIREMENTS

In secondary tillage at a speed of 5 mph (8 km/h) and a depth of 3 in (76 mm) a tractor with 165 PTO hp (124 kW) was required with the mounted harrows. At this speed and depth in primary tillage, a 182 PTO hp (136 kW) tractor was required.

OPERATOR SAFETY

Operation of the Flexi-coil floating hitch cultivator was safe provided normal safety procedures were observed. A slow-moving vehicle sign, safety reflectors and safety chain were provided as standard equipment. When in transport position with harrows attached, the load on the centre section tires could exceed the Tire and Rim Association's maximum load rating.

OPERATOR'S MANUAL

The operator's manual was very good, containing information on safety, specifications, operation, maintenance and trouble shooting. A separate parts list, assembly and harrow manuals were supplied.

MECHANICAL HISTORY

The depth lock actuator link, depth and wing hydraulic lines and depth stop valve were damaged during the test.

RECOMMENDATIONS

The Alberta Farm Machinery Research Centre (AFMRC) recommends the manufacturer:

1. Improve the procedure of adjusting the restraint chain links.
2. Improve mounting of the harrow with the mounted packer/harrow option to prevent movement of the gang in the mounting bracket.
3. Improve the way the adjustor link is connected to the depth lever.
4. Improve routing of the depth and wing hydraulic lines.

Field Technologist: G.A. Magyar
Manager: R.P. Atkins, P.Eng.

MANUFACTURER'S REPLIES TO RECOMMENDATIONS

The manufacturer states with regard to recommendation number:

1. Adjusting restraint chains is part of the initial adjustment and once done does not need to be repeated. The manual has been updated to include new procedures to ease this initial adjustment.
2. A third u-bolt has been added to the main arm of the mounted packer/harrow option.
3. Improvements have been made to prevent the connector bolt from loosening.
4. A hose clamp has been included to prevent damage to hydraulic hoses.

MANUFACTURER'S ADDITIONAL COMMENTS

1. This test machine was equipped with the mounted packer/harrows option so the machine could be used for both tillage and seeding with harrows or mounted packers. This report includes information on the optional mounted packer/harrow arms which are different from the standard Flexi-coil harrow arms.
2. The retail price includes the cost for the mounting wedges which are used for either the 3 in (76 mm) Nok-On spoons or 11 in (279 mm) Nok-On sweeps.
3. To improve residue clearance between the walking beam and shank, beam spindle length has been increased and one hole added to provide an extra 1 or 2 in wheel offset.

GENERAL DESCRIPTION

The Flexi-coil 820 is a trailing, floating hitch cultivator suitable for primary and secondary tillage operations. The cultivator is available in 3 section units with widths ranging from 25 to 44 ft (7.6 to 13.4 m), and 5 section units with widths ranging from 43 to 62 ft (13.1 to 18.9 m). Shank spacings of 7.2, 9 or 12 in (183, 229 or 305 mm) are available.

The centre frame is supported by 2 dual axle wheel sets and 2 castering gauge wheels. Each wing frame is supported by 1 castering gauge wheel and a dual axle wheel set. A single hydraulic cylinder controls tillage depth. Tillage depth is set by adjusting the depth stop adjuster assembly. The cultivator is levelled by the main and wing frame wheel standard link and the depth link adjusters at each gauge wheel.

The triangular sections of the main and wing frames are connected by hinged joints. Hydraulic cylinders connected in parallel fold the wings into transport position. A tractor with dual remote hydraulic controls is needed to operate the cultivator.

The test machine was a 33 ft (10.0 m), 3 section unit with a 13.4 ft (4.0 m) main frame and 2 - 9.8 ft (3.0 m) wing frames. The unit was equipped with 45 shanks spaced at 9 in (229 mm) intervals. Optional equipment included 50°, 550 lb (2.5 kN) shank trips, 3 in (76 mm) Nok-On spoons, 11 in (279 mm) Nok-On sweeps, mounted packer/harrow option and 3 bar harrows.

SCOPE OF TEST

The Flexi-coil 820 floating hitch cultivator was operated in the conditions shown in Table 1 for 138 hours while cultivating 2305 ac (933 ha). The cultivator was evaluated for quality of work, ease of operation and adjustment, power requirements, operator safety and suitability of the operator's manual.

Table 1. Operating Conditions.

FIELD CONDITIONS OPERATION	HOURS	FIELD AREA	
		ac	ha
- Primary	74.5	1148	465
- Secondary	63.5	1157	468
TOTAL	138.0	2305	933
Soil Type:			
- Silt Loam	30	490	198
- Sandy Loam	13	300	122
- Loam	72	1107	448
- Sandy Clay- Loam	11	168	68
- Clay	12	240	97
TOTAL	138	2305	933
Stony Phase:			
- Stone Free	43	765	309
- Occasional	70	1140	462
- Moderately Stony	25	400	162
TOTAL	138	2305	933

The machine evaluated by the Alberta Farm Machinery Research Centre (AFMRC) was configured as described in the General Description, Figure 1, and the Specifications section in Appendix I of this report. The manufacturer may have built different configurations of this machine before and after AFMRC's tests. Therefore, when using this report be sure to check the machine under consideration is the same as the one reported here. If differences exist, assistance can be obtained from AFMRC or the manufacturer to determine changes in performance.

RESULTS AND DISCUSSION

QUALITY OF WORK:

Penetration: Penetrating ability of the Flexi-coil 820 floating hitch cultivator was very good. Penetration was similar for both the 11 in (279 mm) Nok-On sweeps and 3 in (76 mm) Nok-On spoons. Uneven penetration resulted when working in dry, hard primary tillage.

The gauge wheels and dual axle wheel sets had to be properly set to obtain uniform penetration across the width of the cultivator. The flexible frame sections enabled the cultivator to maintain proper penetration when working in moderately rolling to rolling field conditions. Sharp gullies or hills resulted in uneven penetration. Maintaining uniform penetration required making appropriate cultivator adjustments when changing fields.

Depth Uniformity: Depth uniformity of the Flexi-coil 820 floating hitch cultivator was very good in secondary and moist primary conditions. Depth uniformity was reduced when working in dry, hard primary conditions. Tillage depth was very uniform in level to gently rolling terrain provided all adjustments were properly set. There was depth variation in sharply rolling terrain such as when crossing sharp gullies or sharp hill crests.

The sweep pattern allowed for sufficient overlap without running the outside wheel on cultivated soil. Running all wheels on untilled soil helped maintain uniform tillage depth.

Flexibility of the cultivator frame and shank characteristics, Figure 2, determined depth uniformity of the tillage opener. The width of the centre and wing frames and how they were linked determined how well the Unit followed the contours of the field. Shank stiffness and cushion spring preload determined the sweep pitch over a varying range of tillage forces. A shank should maintain a low, constant sweep pitch over the normal range of tillage forces. AFMRC selected 7° as a maximum operating sweep pitch producing an acceptable furrow bottom for most operations. The sweep pitch could be determined during operation by the sweep pitch characteristics of the shank assembly and the soil forces encountered by the sweep.

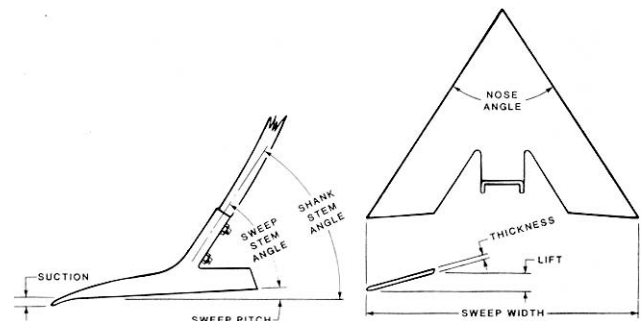

Figure 2. Shank and Sweep Terminology.

The sweep pitch characteristics of the Flexi-coil 550 lb (2.5 kN) trip release shank are shown in Figure 3. The no-load sweep pitch was 2°. The lower portion of the line showed as force was applied to

the sweep the pitch increased due to shank flexing. At a horizontal force of 543 lb (2.4 kN) the shank began to trip as the spring-trip preload was overcome. The point on the curve where the sweep pitch exceeded 7° was 600 lb (2.7 kN).

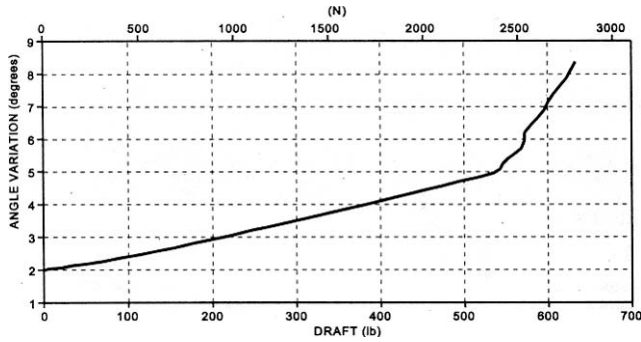

Figure 3. Sweep Pitch for Flexi-coil 820 Shank.

The force encountered by soil tools on the front row of a cultivator operating at different depths is in Appendix II. The Flexi-coil 820 shank force at the 7° sweep pitch was greater than or equal to all shown soil forces. The 11 in (279 mm) Nok-On sweeps or 3 in (76 mm) Nok-On spoons would maintain uniform tillage or seed depth while operating in primary or secondary tillage. The Flexi-coil 820 cultivator would also maintain 16 in (406 mm) sweeps, 2 in (51 mm) spikes and double shoot openers at uniform tillage or seeding depths.

Stone Protection: Stone protection was very good. The lifting pattern for the 550 lb (2.5 kN) trip shank is shown in Figure 4. The maximum lift height of the shank assembly was 11 in (279 mm) when equipped with 11 in (279 mm) Nok-On sweeps or 3 in (76 mm) Nok-On spoons. There was no shank damage during the test period.

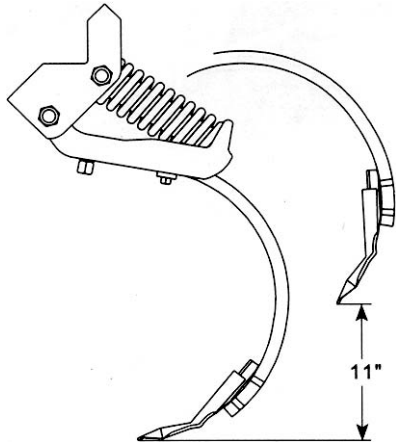

Figure 4. Flexi-coil 500 lb Shank Trip Mechanism.

Residue Clearance: The Flexi-coil floating hitch cultivator was good in clearing normal amounts of trash. The 4 row, 30 in (762 mm) sweep-to-frame clearance and 9 in (229 mm) shank spacing allowed trash to clear the cultivator. The 9 in (229 mm) sweep pattern, Appendix IV, required shanks be mounted behind the front tire of the dual axle wheel sets, reducing the clearance between the walking beam and shank. Plugging usually occurred at the walking beam when working in moist soil conditions with heavy trash locations. Occasional plugging also occurred at the centre of the unit due to the narrow lateral spacing between shanks.

Soil Surface: When working in primary soil conditions with the harrows set at a less aggressive working angle, the Flexi-coil 820 left soil ridges from the rear shank row, with the majority of the straw remaining on the surface. Using a more aggressive harrow angle reduced soil ridging, producing a uniform seedbed with less straw remaining on the soil surface, Figure 5. When working in secondary soil conditions with light to moderate trash coverage and using a less aggressive working angle there was minimum soil ridging, with the majority of the trash left on the soil surface. When working in heavy trash conditions, trash would wrap around the cultivator shanks,

increasing soil ridging. Lumps of trash were also left on the soil surface when using a more aggressive harrow angle. Therefore, a less aggressive harrow angle was used to help distribute the trash more evenly.



Figure 5. Soil Surface: Left: Aggressive Harrow Angle. Right: Less Aggressive Harrow Angle.

Skewing and Stability: The Flexi-coil 820 was stable and did not skew sideways in typical field conditions. Minimal skewing occurred when working in dry, hard primary soil conditions and in hilly terrain. The sweep pattern, Appendix IV, was symmetrical and did not impose any side forces on the cultivator during tillage. With 11 in (279 mm) Nok-On sweeps the cultivator had to skew more than 2° before tillage misses occurred.

EASE OF OPERATION AND ADJUSTMENT

Maintenance: Ease of performing routine maintenance was very good. Grease fittings were provided for all frame pivot locations, castor pivots, walking beam assemblies, depth adjuster linkages and wheel hubs. The castor pivots, hitch pole pivots, king post pivots, wing pivots, centre and wing frame pivots, and walking beam assemblies were greased every 50 hours. The depth adjuster linkages and wheel hubs were greased every 200 hours. The manufacturer recommended maintaining proper tire pressure and wheel bolt tightness. A detailed maintenance schedule was provided.

One person could replace the 45 sweeps in 20 minutes. The same amount of time was required when switching from sweeps to spoons. The replacement of 1 shank assembly required 10 minutes.

Hitching: Ease of hitching to the Flexi-coil 820 cultivator was very good. The hitch jack and hitch link made one man hitching easy. Hitching required connecting the safety chain. The floating hitch maintained positive hitch weight in both transport and field position.

Transporting: Ease of transporting the Flexi-coil 820 cultivator was very good. The cultivator was placed into transport position, Figure 6, in 5 minutes. The main frame was secured by the depth control safety lock. The wings were placed into transport position in an over-centred position, eliminating the need for a mechanical safety lock. Proper initial adjustment of the wing lift linkage was required to eliminate stress on the wing during transport.



Figure 6. Transport Position.

Transport width of the test machine was 17.8 ft (5.4 m), while transport height was 15.2 ft (4.6 m) with sweeps attached. Care was needed when transporting on public roads, through gates, over bridges and beneath power lines. Sufficient clearance between the tractor's rear tires and the cultivator allowed for sharp turns in both field and transport position.

The 820 cultivator towed well, without sway or bounce, at a tractor speed of 20 mph (32 km/h). A sweep-to-ground clearance of 8 in (203 mm) provided safe ground clearance.

Frame Levelling: Ease of levelling the frame was good. The cultivator was levelled using a ground-to-frame dimension of 40.5 in (1029 mm) for the 9 in (229 mm) shank spacing.

The adjuster link assemblies, Figure 7, connected to the depth control linkage and wheel standards provided lateral levelling of the main frame and wing sections.

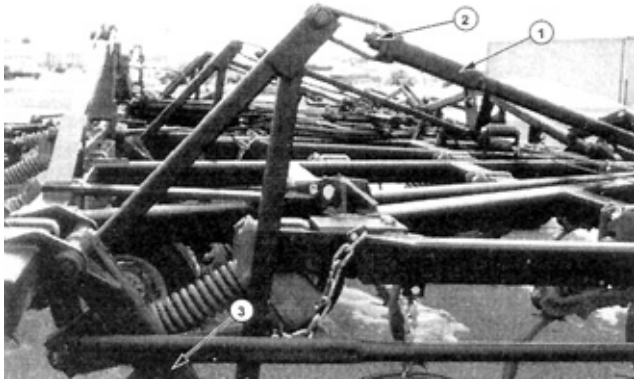

Figure 7. Adjustor Link Assembly. (1) Wheel Standard Link, (2) Adjusting Bolt and (3) Wheel Standard.

Front-to-back levelling was obtained by adjusting the height of the castor wheels, Figure 8.

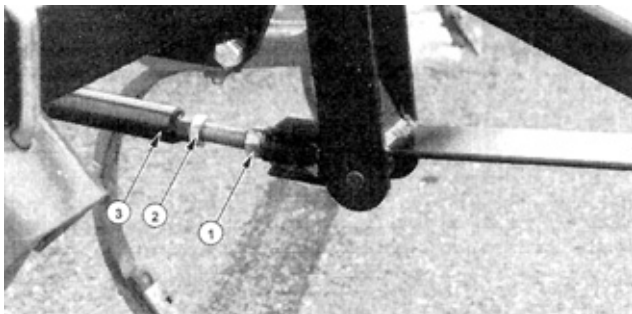

Figure 8. Depth Link Adjustor Assembly. (1) Adjusting Nut, (2) Jam Nut and (3) Depth Link Adjustor Rod.

Level ground was needed for initial frame levelling. Once levelled, the wheel standard restraint chain links were adjusted to the proper length. The manufacturer recommended placing the cultivator in the fully raised position before adjusting the chain link. In the fully raised position the depth link adjuster rod, Figure 9, blocked access to the lower restraint chain link bolt, preventing adjustment of the chain link. The AFMRC recommends the manufacturer improve the procedure of adjusting the restraint chain links. The manufacturer recommended final frame levelling should be completed while working at the desired tillage depth. The floating hitch eliminated the need to adjust hitch height.

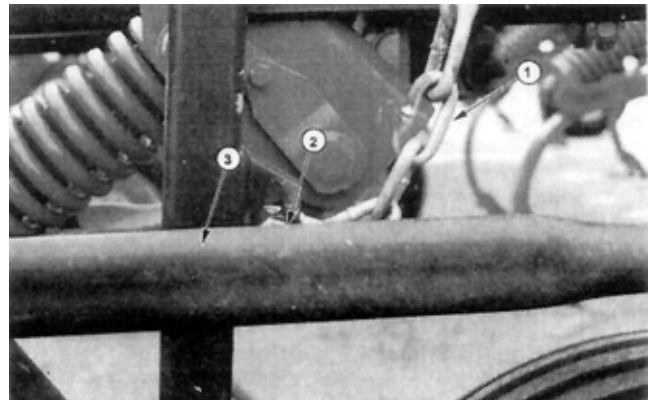

Figure 9. Restraint Chain Link Assembly: (1) Chain Link, (2) Lower Bolt and (3) Depth Link Adjustor Rod.

Depth Adjustment: Ease of setting the tillage depth was very good. Tillage depth was controlled by a single hydraulic cylinder mechanically connected to each dual axle wheel standard. The depth stop adjustment system, Figure 10, was located by the centre frame's right castor wheel. Tillage depth was changed by repositioning the depth stop adjuster assembly on the depth stop rod. The depth stop adjuster assembly engaged the depth stop valve at the desired tillage.

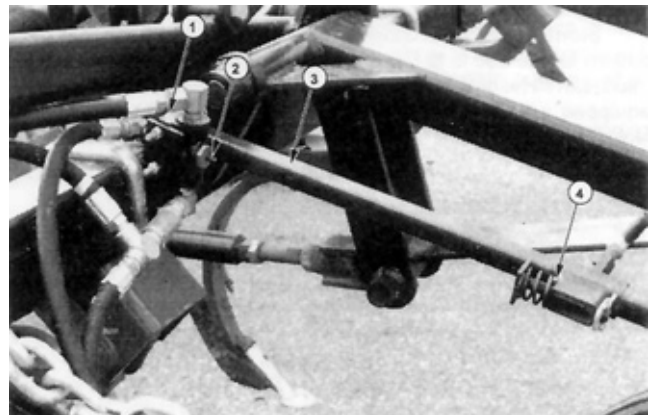

Figure 10. Depth Stop Adjustment System. (1) Depth Stop, (2) Shut-off Needle, (3) Depth Stop Rod and (4) Depth Stop Adjustor Assembly.

Harrow Adjustment: Ease of adjusting the arm on the optional packer/harrows was good. Selecting 1 of the 6 available detents adjusted the harrow tine angle. Harrow downward pressure was adjusted by the location of the top pin and spring length. Three working positions were supplied for the top pin, while the spring length could be varied between 8.5 and 13.0 in (216 and 330 mm). The manufacturer supplied a spring pressure chart indicating the working pressure for the corresponding pin location and spring length. The supplied spring adjustment wrench was used to adjust the spring length.

The harrow frame was levelled by rotating the harrow gang on the mounting bracket. Two u-bolts secured the frame to the harrow extension arm. Turning the cultivator in a raised position caused excessive bouncing on the outside wing harrow arms. The harrow gang turned in the mounting bracket, requiring the frame to be relevelled. The AFMRC recommends the manufacturer improve the mounting of the harrow use with the mounted packer/harrow option to prevent movement of the gang in the mounting bracket.

POWER REQUIREMENTS

AFMRC has measured power requirements on several cultivators in various field conditions as explained in Appendix III. From these field measurements, average power requirements have been determined to assist farmers in matching tractor and cultivator

sizes. The tractor sizes have been adjusted to include tractive efficiency and represent a tractor operating at 80% of maximum power take-off rating.

In typical secondary conditions, at a speed of 5 mph (8 km/h) and a depth of 3 in (76 mm), average cultivator PTO power requirements were 4.3 hp/ft (10.5 kW/m), Appendix III. In typical primary conditions at the same speed and depth, average PTO power requirements were 4.8 hp/ft (11.7 kW/m). Additional power required to pull the mounted harrows was 0.7 hp/ft (1.7 kW/m). Tractor PTO horsepower recommended to pull a 33 ft (10 m) Flex-coil 820 floating hitch cultivator with mounted harrows would be 165 hp (124 kW) in secondary conditions and 182 hp (136 kW) in primary conditions, Table 2. Additional power would be required when tilling deeper or working in hilly terrain.

Table 2. Tractor Size: PTO Power [hp (kW)] Required to Operate a Typical 33 ft (10 m) Floating Hitch Cultivator with Mounted Harrows.

OPERATION	DEPTH		SPEED			
	in	mm	4.0 mph	6.4 km	5.0 mph	8.0 km
Primary	2.0	50	112	84	135	101
	3.0	76	149	111	182	136
	4.0	102	185	138	224	167
Secondary	2.0	50	99	74	122	91
	3.0	76	135	101	165	123
	4.0	102	172	128	208	155

OPERATOR SAFETY

The Flexi-coil 820 floating hitch cultivator was safe to operate when normal safety precautions were observed. The test unit was 17.8 ft (5.4 m) wide in transport, which required caution when towing on public roads, over bridges and through gates. A slow-moving vehicle sign, safety reflectors and hitch safety chain were provided as standard equipment.

The load on the centre section tires could exceed the Tire and Rim Association's maximum load rating when in transport position with harrows attached.

OPERATOR'S MANUAL

The operator's manual was very good. The manual contained useful information on safety, specifications, operation, maintenance and trouble shooting. A separate parts list and assembly manual were included. A manual for the mounted packer/harrow option was also included. The harrow manual contained information on assembly, adjustment and operation.

MECHANICAL HISTORY

Table 3 outlines the mechanical history of the Flexi-coil 820 floating hitch cultivator during 138 hours of operation while cultivating 2305 ac (933 ha). The intent of the test was evaluation of functional performance. An extended durability evaluation was not conducted.

Table 3. Mechanical History.

ITEM	OPERATING HOURS	EQUIVALENT FIELD AREA	
		ac	ha
repaired depth lock actuator link at	26	328	133
	80	1513	613
	114	1905	771
replaced Nok-On spoons at	39	629	255
	99	1800	729
replaced broken harrow mounting v-bolt at	83	1563	633
replaced broken depth indicator chain at	102	1820	737
noticed damaged depth and wing hydraulic lines at		end of test	
replaced faulty depth stop valve at		end of test	

DISCUSSION OF MECHANICAL PROBLEMS

Depth Lock Adjustor Link: The bolt attaching the depth lock adjustor link to the depth lock lever worked free during field work, Figure 11. The bolt length did not allow the lock nut to secure the

adjustor link to the depth lever properly. The adjustor link eventually became damaged and was replaced. The AFMRC recommends the manufacturer improve the way the adjustor link is connected to the depth lever.

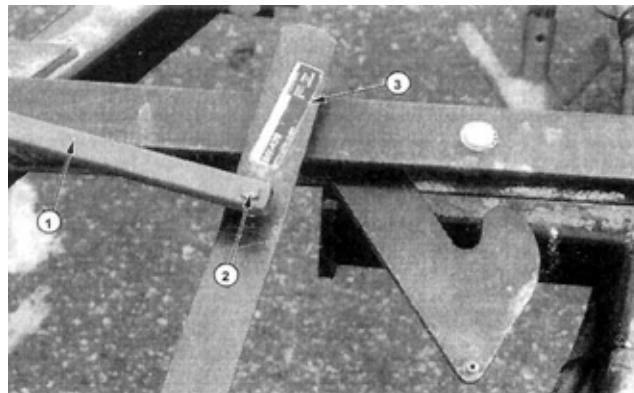

Figure 11. Depth Lock Adjustor Link: (1) Adjustor Link, (2) Bolt and (3) Depth Lock Lever.

Opener Wear: The Nok-On spoons were replaced after completing 629 ac (255 ha) of fall seeding. The second set of Nok-On spoons were replaced after 1171 ac (474 ha) or 26 ac (11 ha) per spoon, Figure 12. The left spoon was removed from the shank operating in the tractor and centre section wheel tracks, while the right spoon was removed from the shank operating on the wing section. The percentage of wear for the 2 spoons was calculated to be 43 and 25%, respectively. Replacement of the spoon was considered necessary after showing 56% wear. The Nok-On sweeps were operated for 505 ac (204 ha) or 11 ac (4.5 ha) per sweep. The sweeps showed very little wear after 11 ac (4.5 ha) per sweep. Cost of the replacement Nok-On spoon and sweep was \$6.60 and \$8.30 each, respectively.

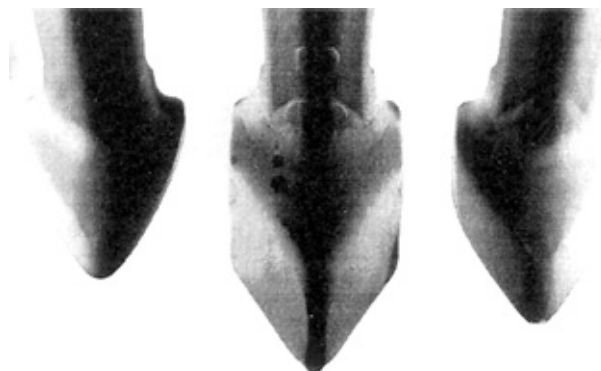

Figure 12. Opener Wear.

Damaged Depth and Wing Hydraulic Lines: The hydraulic lines were routed through the left beam of the hitch to the centre section. As the hitch moved the lines rubbed on the frame, Figure 13. Continuous scraping would eventually cause the hydraulic lines to fail. The AFMRC recommends the manufacturer improve the routing of the depth and wing hydraulic lines.



Figure 13. Damaged Depth and Wing Hydraulic Lines.

**APPENDIX I
SPECIFICATIONS**

MAKE: Flexi-coil
MODEL: 820 Floating Hitch Cultivator
SERIAL NUMBER: 0820 B00 P060124

MANUFACTURER: Flexi-coil Ltd.
 1000 71 Street East
 P.O. Box 1928
 Saskatoon, SK. S7K 3S5
 Phone: 306/934-3500

DIMENSIONS:

	<u>Field Position</u>	<u>Transport Position</u>
-height	5.5 ft (1.7 m)	15.2 ft (4.6 m)
-width	34.5 ft (10.5 m)	17.8 ft (5.4 m)
-length	25.3 ft (7.7 m)	25.3 ft (7.7 m)
-mounted harrows	28.8 ft (8.8 m)	28.8 ft (8.8 m)
-ground clearance	8.0 in (203 mm)	8.0 in (203 mm)
-effective cutting width		
-sweep	34.0 ft (10.4 m)	
-spoon	33.2 ft (10.1 m)	
-wheel tread		
-centre section	13.3 ft (4.1 m)	13.3 ft (4.1 m)
-overall	31.2 ft (9.5 m)	

SHANKS:

-number	45
-type	550 lb (2.5 kN) trip
-cross section	1 x 2 in (25 x 51 mm)
-stem angle	50°
-sweep hole spacing	2.25 in (57 mm)
-sweep bolt size	0.5 in (13 mm)
-lateral spacing	9 in (229 mm)
-trash clearance	30 in (762 mm)
-number of rows	4 offset rows
-distance between rows	27.75 to 33.75 in (705 to 857 mm) 20.0 to 36.0 in (508 to 914 mm) 28.0 to 38.0 in (711 to 965 mm)

ARROWS:

-type	bent tine
-number	5 - 6.0 ft (1.8 m), 1 - 4.5 ft (1.4 m)
-rows	3 - 12 in (305 mm) spacing
-tine diameter	0.375 in (9.5 mm)
-tine length	15.375 in (391 mm)
-tine spacing	9.0 in (229 mm)

HITCH: floating

DEPTH CONTROL: single hydraulic cylinder, chain and bar linkages connect cylinder to wheel standards

FRAME:

-main cross section	4 in (102 mm) square tubing
-wing cross section	4 in (102 mm) square tubing

TIRES:

-centre section	4 - 9.5L x 15 FI, 6 ply
-wing section	4 - 9.5L x 15 SL, 8 ply
-centre gauge wheels	2 - 9.5L x 15 FI, 6 ply
-wing gauge wheels	2 - 9.5L x 15 SL, 8 ply

NUMBER OF LUBRICATION POINTS: 3 - king pin
 10 - frame pivots
 2 - floating hitch pivot
 8 - castor swivels (2/castor)
 4 - walking beams
 6 - harrow arms
 4 - depth level adjustments
 12 - wheel hubs

HYDRAULIC CYLINDERS:

-depth control	1 - 4 x 24 in (102 x 610 mm) 1.75 in (44 mm) rod
-wing lift	2 - 4 x 32 in (102 x 813 mm) 1.75 in (44 mm) rod

WEIGHTS:

	<u>Field Position</u>	<u>Transport Position</u>
-hitch	400 lb (181 kg)	400 lb (181 kg)
-right wing castor	610 lb (277 kg)	
-right wing transport	1640 lb (744 kg)	
-right centre castor	1150 lb (522 kg)	2030 lb (921 kg)
-right centre transport	2920 lb (1325 kg)	4320 lb (1960 kg)
-left centre transport	2980 lb (1352 kg)	4410 lb (2001 kg)
-left centre castor	1170 lb (531 kg)	1910 lb (867 kg)
-left wing transport	1590 lb (721 kg)	
-left wing castor	610 lb (277 kg)	
TOTAL	13,070 lb (5930 kg)	13,070 lb (5930 kg)

WEIGHTS: (WITH HARROWS)

	<u>Field Position</u>	<u>Transport Position</u>
-hitch	400 lb (181 kg)	400 lb (181 kg)
-right wing castor	580 lb (263 kg)	
-right wing transport	1740 lb (790 kg)	
-right centre castor	910 lb (413 kg)	1380 lb (626 kg)
-right centre transport	470 lb (1574 kg)	5300 lb (2405 kg)
-left centre transport	3400 lb (1543 kg)	5420 lb (2459 kg)
-left centre castor	890 lb (404 kg)	1290 lb (586 kg)
-left wing transport	1820 lb (826 kg)	
-left wing castor	580 lb (263 kg)	
TOTAL	13,790 lb (6257 kg)	13,790 lb (6257 kg)

OPTIONS INCLUDED

ON TEST MACHINE: 33 ft (10 m) width
 550 lb shank trip
 9.0 in (229 mm) shank spacing
 11.0 in (279 mm) Nok-On sweeps and
 3.0 in (76 mm) Nok-On spoons
 3 bar-mounted harrows
 mounted packer/harrow option

OTHER AVAILABLE OPTIONS:

3 section units, widths from 25 to 44 ft (7.6 to 13.4 m)
5 section units, widths from 43 to 62 ft (13.1 to 18.9 m)
7.2 and 12.0 in (183 or 305 mm) shank spacing
350 lb, 650 lb and rigid shank trips
4 bar mounted harrows
hydraulic end markers
47° shank with 7/16 in (11 mm) bolt and 1.75 in (44 mm) centre

APPENDIX II

SOIL FORCES TABLE

The following tables give typical horizontal forces acting on sweeps, spikes and double shoot openers located in the front row of a cultivator while operating at different depths in primary and secondary tillage on the prairies. Higher forces may be encountered in extremely heavy, dry or compacted soils.

These values can be used to determine how well the shank assemblies are suited to the various operations. Comparing the sweep pitch curve of the assembly to these soil forces will show whether the assembly will hold the soil tool below the acceptable 70 sweep pitch.

Table 4. Forces Required [lb (kN)] in Primary Tillage for Various Soil Tools.

DEPTH		SWEEPS						SPIKE		DOUBLE SHOOT OPENERS	
in	mm	Field Cultivator 11 in (275 mm)		Heavy Duty Cultivator 12 in (305 mm)		16 in (406 mm)		2 in (50 mm)		lb	kN
		lb	kN	lb	kN	lb	N	lb	kN		
2	50	120	0.5	190	0.8	220	1.0	---	---	97	0.4
3	75	140	0.6	230	1.0	280	1.2	150	0.7	183	0.8
4	100	180	0.8	310	1.4	370	1.6	190	0.8	268	1.2

Table 5. Forces Required [lb (kN)] in Secondary Tillage for Various Soil Tools.

DEPTH		SWEEPS						SPIKE		DOUBLE SHOOT OPENERS	
in	mm	Field Cultivator 11 in (275 mm)		Heavy Duty Cultivator 12 in (305 mm)		16 in (406 mm)		2 in (50 mm)		lb	kN
		lb	kN	lb	kN	lb	kN	lb	kN		
2	50	110	0.5	170	0.8	200	0.9	---	---	83	0.4
3	75	140	0.6	220	1.0	270	1.2	130	0.6	169	0.8
4	100	170	0.8	280	1.2	340	1.5	180	0.8	255	1.1

APPENDIX III

POWER REQUIREMENTS

Draft Characteristics: Draft requirements have been measured on several cultivators in various field conditions over the past years. Average draft requirements have been determined from these measurements.

Draft requirements for the same cultivator, in the same field, may vary by as much as 30% in 2 different years due to changes in soil conditions. Variations in soil conditions affect draft much more than variations in machine make, making it difficult to measure any significant draft differences between makes of cultivators.

Since there are almost no draft differences between machines, AFMRC has averaged the results obtained over the years and has used these to determine tractor size requirements.

Recommended Tractor Size: The following tables show tractor PTO power required to pull cultivators in various conditions at the given depths and speeds. Tractor power requirements have been adjusted to include a tractive efficiency of 80% in primary and 70% in secondary tillage and represent a tractor operating at 80% of maximum PTO power on a level field. These power requirements can be used along with the maximum PTO ratings, as determined by Nebraska tests, OECD tests, or as presented by the tractor manufacturer, to select the appropriate tractor. Higher power will be required in hills or in heavy soils. Cultivators with marked differences in spacing, number of rows or configurations may require more or less power.

Recommended tractor size may be determined by selecting the required horsepower per foot from the appropriate table and multiplying by the cultivator width. For example, in primary tillage at 3 in (75 mm) and 5 mph (8.0 km/h), 4.8 hp/ft (11.7 kW/m) is required. Therefore, for a 37 ft (11.3 m) cultivator in those conditions, 178 PTO hp (133 kW) is recommended.

Table 6. Tractor PTO Power Per Unit Width [hp/ft (kW/m)] Required in Primary Tillage.

DEPTH		SPEED					
in	mm	4.0	6.4	5.0	8.0	6.0	9.7
		mph	km	mph	km	mph	km
2	50	2.7	6.6	3.4	8.3	4.1	10.0
3	75	3.8	9.3	4.8	11.7	5.8	14.2
4	100	4.9	12.0	6.1	14.9	7.4	18.1

Table 7. Tractor PTO Power Per Unit Width [hp/ft (kW/m)] Required in Secondary Tillage.

DEPTH		SPEED					
in	mm	4.0	6.4	5.0	8.0	6.0	9.7
		mph	km	mph	km	mph	km
2	50	2.3	5.6	3.0	7.3	3.6	9.7
3	75	3.4	8.3	4.3	10.5	5.2	12.7
4	100	4.9	11.0	5.6	13.7	6.8	17.6

APPENDIX IV

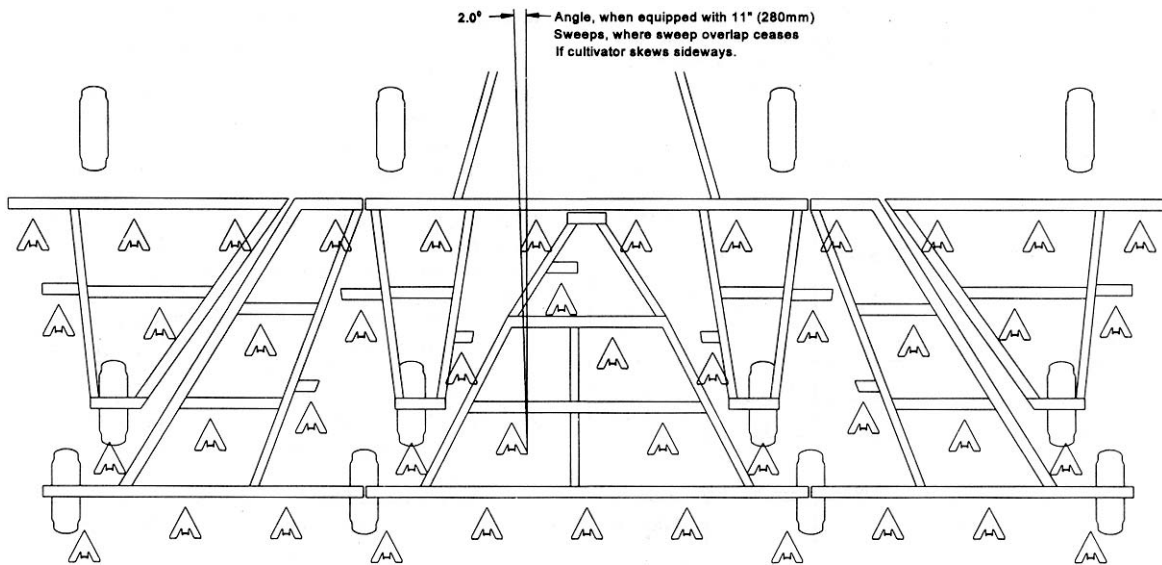

APPENDIX V MACHINERY RATINGS

The following scale is used in Alberta Farm Machinery Research Centre (AFMRC) Evaluation Reports.

- Excellent
- Very Good
- Good
- Fair
- Poor
- Unsatisfactory

SUMMARY CHART

FLEXI-COIL 820 FLOATING HITCH CULTIVATOR

RETAIL PRICE: \$40,186.50 (February 1997, f.o.b. Lethbridge, Alberta) for 33 ft (10.0 m) wide cultivator complete with 45 - 550 lb shank trips spaced at 9 in (229 mm), 11 in (279 mm) Nok-On sweeps, 3 in (76 mm) Nok-On spoons, mounting wedges and mounted harrow packer option and 3 bar mounted harrows.

QUALITY OF WORK:

-penetration	very good; uneven in dry, hard primary tillage
-depth uniformity	very good; reduced in dry, hard primary tillage
-stone protection	very good; trip height of 11 in (279 mm)
-residue clearance	good; occasional plugging at walking beam locations
-soil surface	surface finish affected by harrow tine angle
-skewing and stability	stable

EASE OF OPERATION AND ADJUSTMENT:

-maintenance	very good; replacing Nok-On sweeps or spoons required 20 minutes
-hitching	very good; safety chain provided
-transporting	very good; ready for transport in 5 minutes
-frame levelling	good; level ground required for initial frame levelling
-depth adjustment	very good; set by repositioning depth stop adjuster assembly
-harrow adjustment	good; downward pressure set by pin location and spring length

POWER REQUIREMENTS:

-secondary tillage	165 PTO hp (124 kW) at 3 in (76 mm) and 5 mph (8 km/h) with mounted harrows
-primary tillage	182 PTO hp (136 kW) at 3 in (76 mm) and 5 mph (8 km/h) with mounted harrows

OPERATOR SAFETY: slow moving vehicle sign, safety reflectors and hitch safety chain provided

OPERATOR'S MANUAL: **very good;** supplied instructions on safety, operation, maintenance, adjustment and trouble shooting

MECHANICAL HISTORY: depth lock actuator link, depth and wing hydraulic lines and depth stop valve damaged during the test



3000 College Drive South
Lethbridge, Alberta, Canada T1K 1L6
Telephone: (403) 329-1212
FAX: (403) 329-5562
<http://www.agric.gov.ab.ca/navigation/engineering/afmrc/index.html>

Prairie Agricultural Machinery Institute

Head Office: P.O. Box 1900, Humboldt, Saskatchewan, Canada S0K 2A0
Telephone: (306) 682-2555

Test Stations:

P.O. Box 1060

Portage la Prairie, Manitoba, Canada R1N 3C5

Telephone: (204) 239-5445

Fax: (204) 239-7124

P.O. Box 1150

Humboldt, Saskatchewan, Canada S0K 2A0

Telephone: (306) 682-5033

Fax: (306) 682-5080