

Evaluation Report 497

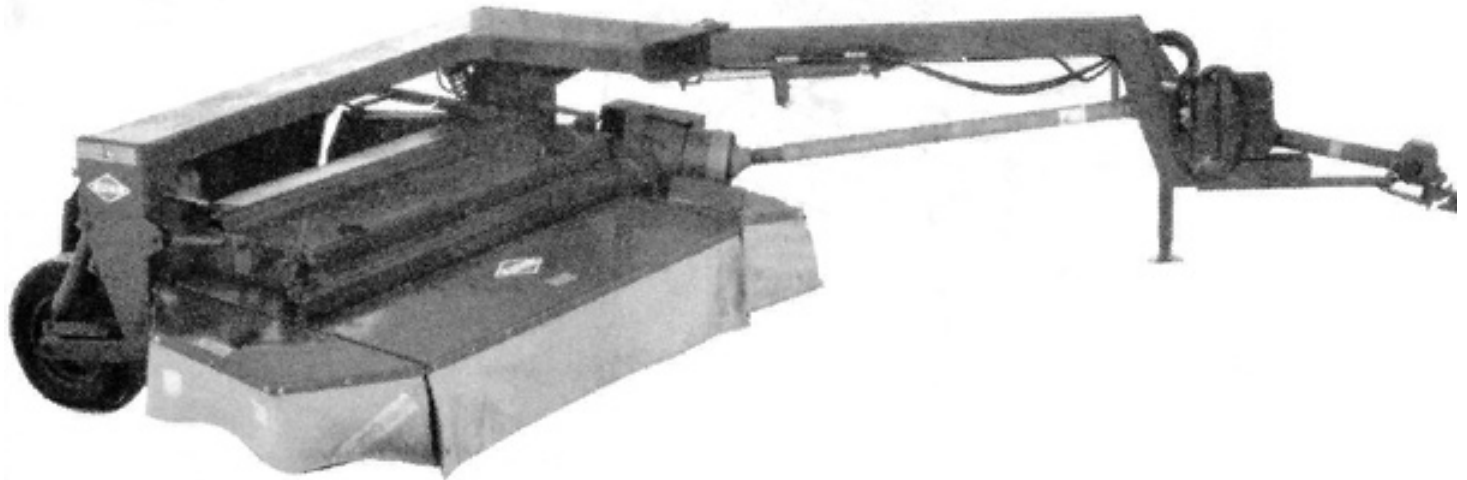

Kuhn FC300 Mower Conditioner

A Co-operative Program Between



KUHN FC300 MOWER CONDITIONER

MANUFACTURER:

Kuhn S.A.
B.P. 60
67706 Saverne Cedex
France
Tel: (88) 91-21-10

DISTRIBUTOR:

Alteen Distributors Ltd.
P.O. Box 6450
Wetaskiwin, Alberta
T9A 2G2
Tel: (403) 352-6061

RETAIL PRICE: \$17,061.00 (April, 1986 f.o.b. Portage la Prairie, Manitoba)

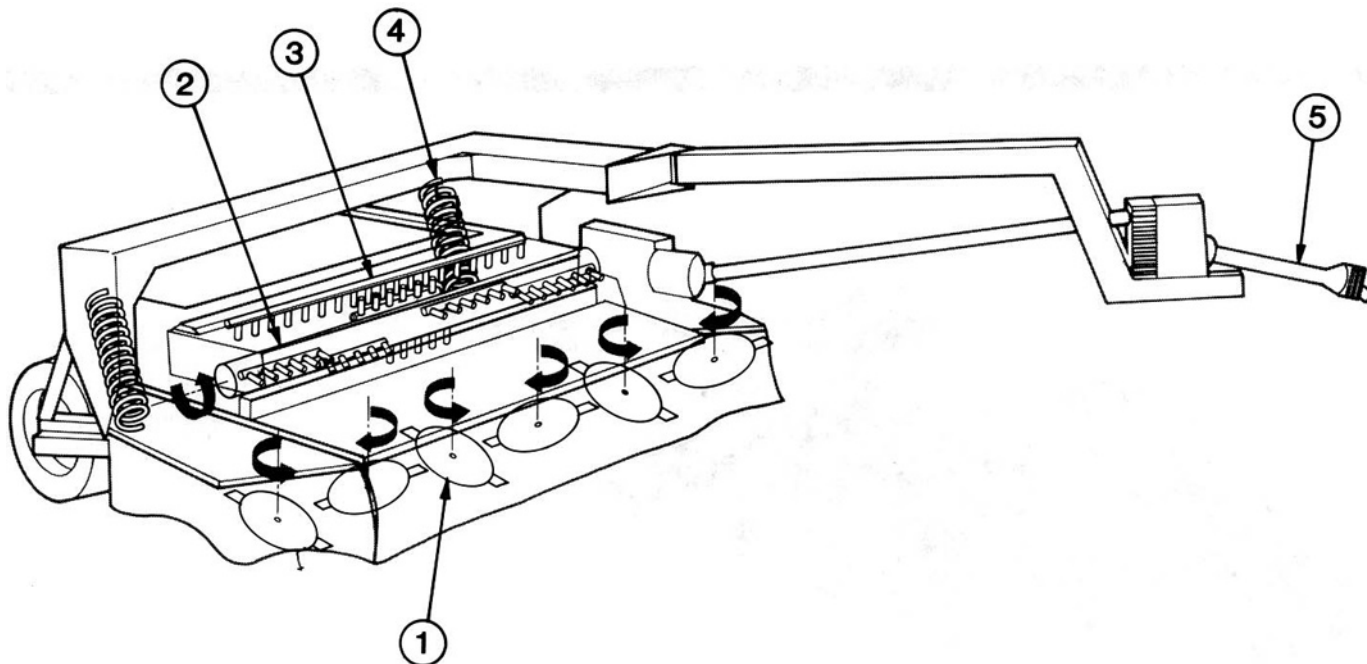

FIGURE 1. Kuhn FC300 Mower Conditioner: (1) Rotary Cutting Discs, (2) Conditioning Rotor, (3) Conditioning Comb, (4) Floatation Spring, (5) Power Take-Off.

SUMMARY

Quality of Work: Performance of the cutting discs was excellent even when cutting damp or fine stemmed crops.

Performance of the conditioning rotor and comb was very good in all crops. Windrow formation was very good.

Rate of Work: The average continuous ground speed for the Kuhn FC300 was 8 mph (13 km/h). Field speed was limited by field roughness and the ability of the operator, in smooth fields ground speeds up to 18 mph (29 km/h) were attained.

Average continuous workrate was 9 acres/h (3.6 ha/h).

Ease of Operation and Adjustment: The ease of operation and maintenance was very good. Changing of a complete set of knives took 1/2 hours. Daily service and lubrication took 1/2 hour.

Operator Safety: No safety hazards were apparent.

Operator's Manual: The operator's manual was very good.

Mechanical History: One minor mechanical problem occurred during the test.

RECOMMENDATIONS

It is recommended that the manufacturer consider:

1. Supplying, as standard equipment, a power take-off shaft

with an accessible grease fitting.

2. Modifying the extra high skid shoes.
3. Installing a "Slow Moving Vehicle" emblem.

Station Manager: G.M. Omichinski

Project Engineer: C.W. Chapman

THE MANUFACTURER STATES THAT

With regard to the recommendation:

1. The PTO with accessible grease fitting, is being supplied as standard equipment on all equal angle hitch FC250/300 Mower Conditioners starting with the 1986 model year.
2. For applications requiring higher skid shoes than those supplied with the machine, Kuhn recommends modifying the standard shoes which will prevent the problems experienced by PAMt. The extra skid shoes supplied with the machine, were fabricated for a specialized application and were not of Kuhn design.
3. At the present time, 2 holes are drilled into the rear of the main frame and bolts provided for the installation of "Slow Moving Vehicle" emblems. Kuhn machines are distributed worldwide, for this reason they are not supplied with items for specific countries at the time of assembly. We will investigate the possibility of supplying the SMV emblems at the distributor level for machines in North America.

GENERAL DESCRIPTION

The Kuhn FC300 is a pulltype, 1000 or 540 rpm power-take-off driven mower conditioner. The rigid cutting platform uses six horizontal rotary cutting discs, each with two swinging knives. A rotor with swinging fingers and an adjustable comb conditions the crop. Adjustable shields form a windrow.

Detailed specifications are given in APPENDIX I and FIGURE 1 shows the location of the major components.

SCOPE OF TEST

The Kuhn FC300 was operated in the crops shown in TABLE 1 for 178 hours while harvesting 925 acres (370 ha).

It was evaluated for quality of work, rate of work, ease of operation, power requirements, operator safety, and suitability of the operator manual.

TABLE 1, Operating Conditions

CROP	HOURS	EQUIVALENT FIELD AREA	
		ac	(ha)
Alfalfa	78	400	(160)
Heavy Grass	30	150	(60)
Alfalfa/Grass	33	155	(62)
Alfalfa/Timothy	21	135	(54)
Alfalfa/Brome	8	45	(18)
Sorghum	8	40	(16)
Total:	178	925	(370)

RESULTS AND DISCUSSION

QUALITY OF WORK

Windrow Formation: The Kuhn FC300 produced good quality windrows in most crops, as shown in FIGURE 2 & FIGURE 3. Windrow formation was controlled by two adjustable side shields and a canvas top baffle. Shield extensions could be bolted to the side shields for use in light crops.



FIGURE 2. Windrow Formation in Heavy Crop.



FIGURE 3. Windrow Formation in Light Crop.

The centre delivery and equal angle hitch allowed a continuous windrow to be formed around corners.

Cutting Ability: Cutting ability of the 2 knife rotary discs was excellent in all crops. Fine stemmed or damp crops did not affect cutting ability.

Forward speed did not affect cutting ability, even in heavy crops. Speed was limited by field roughness.

Stubble: The Kuhn FC300 produced ideal stubble in most crops. In damp or fine stemmed crops, irregular or ragged stubble was produced when the FC300 was operated with dull knives.

Floatation: Two adjustable springs provided header floatation on the Kuhn FC300. Six skid shoes allow the cutting discs to follow ground contours.

Three sets of skid shoes were provided with the machine. Performance of the low and high shoes was very good in all field conditions. The extra high shoes packed with mud and uprooted several plants, especially in soft fields. It is recommended the manufacturer consider modifying the extra high skid shoes.

Floatation was very good in all field conditions.

Conditioner Performance: The Kuhn FC300 was equipped with a rotor type conditioner with swinging fingers, which pass between stationary fingers on an adjustable comb. As the crop passes between the fingers of the comb, the plant stems are bruised sufficiently to condition the crop. This type of conditioning is different than the crimping style of roller conditioners, but is just as effective.

The adjustable comb has five settings, in relation to its position with the rotor, and is also reversible, presenting either a round surface to the crop or a sharp surface to the crop.

Two rotor speeds are available making a total of 20 possible conditioning settings available.

The purpose of a conditioner is to reduce curing time, by crimping the plant stems. This also results in more uniform drying.

FIGURE 4 compares the effect of conditioning of the Kuhn FC300 with a 18 ft (5.4 m) windrow without a conditioner. The use of a conditioner will likely permit baling one-half to one day earlier.

The tests were carried out with the rotor set on low speed, using the round side of the comb for conditioning, with the comb set in Position 1 and Position 5.

Much variation in drying time can be expected due to weather conditions at the time of curing.

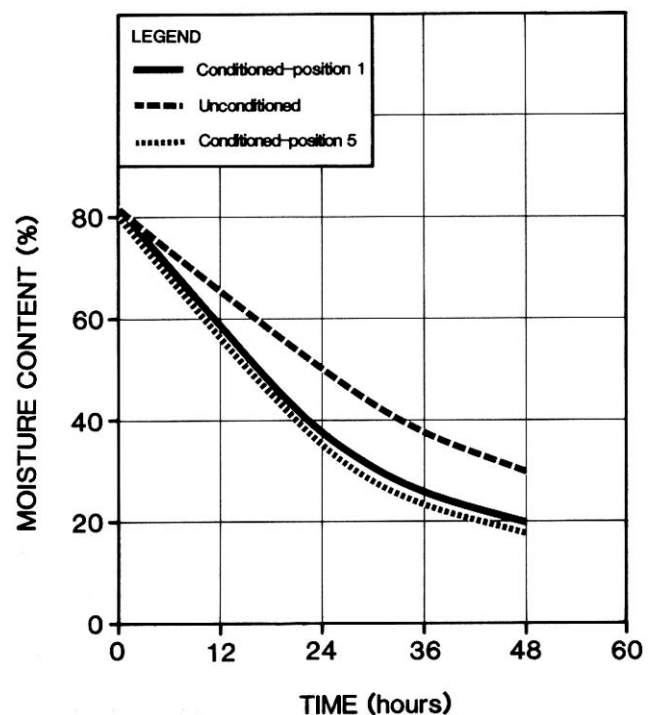

FIGURE 4. The effect of conditioning in alfalfa (3.5 ton/acre).

Leaf Loss: Leaf loss from the Kuhn FC300 was negligible, with the conditioner set according to the manufacturer's instructions.

The uniform drying of the windrow which resulted from the conditioning of the crop, also reduces leaf loss in baling.

RATE OF WORK

The average continuous field speed was 8 mph (13 km/h) and the average continuous work rate was 9 acres/h (3.6 ha/h).

Average daily work rates are lower than continuous work rates because continuous rates do not account for time due to turning, and other field irregularities.

A peak ground speed of 18 mph (29 km/h) was measured in a 3.5 ton/acre (7.8 t/ha) crop of alfalfa.

EASE OF OPERATION

Hitching: The Kuhn FC300 was equipped with an equal angle hitch which was attached to the tractor drawbar. The reversible power take-off shaft permitted use at either 540 or 1000 PTO rpm.

Controls: The mower conditioner was lifted by the tractor hydraulics through two cylinders attached to the ground wheels.

Transporting: The Kuhn FC300 was transported by retracting the drawpole locking pin by means of a rope from the tractor seat, moving the drawpole to the right and engaging the locking pin in the transport position.

The Kuhn FC300 was also tested with a remote cylinder to replace the manual locking pin. A second pair of remote tractor hydraulics was required. The remote cylinder allowed the operator to change from field to transport position using the tractor hydraulics.

The Kuhn FC300 transported well at all tractor speeds and had adequate ground clearance.

The Kuhn FC300 was not equipped with a "Slow Moving Vehicle" emblem. It is recommended that the manufacturer consider installing one.

Adjustments: Adjustments of the conditioning rotor and comb were easy. The conditioning rotor speed was adjustable by interchanging drive sheaves.

Floation springs were easily adjusted by means of a bolt and locking nut.

Changing or reversing the knives took an operator 1-1/2 hours for a complete set of knives. It was necessary to raise the mower conditioner, raise the front shield, and clean dirt and crop residue from the cutter bar. Wrenches for changing the knives were supplied with the machine. The use of a pneumatic impact wrench rendered the changeover easier.

Lubrication: The Kuhn FC300 was equipped with eleven pressure grease fittings which required daily lubrication. Several points required daily oiling.

Three gear boxes required weekly checking and a seasonal oil change.

To check the oil level in the cutter bar, it was necessary to level the machine, remove two plugs and dip a short piece of clean wire into the cutter bar. Complete lubrication and inspection took approximately 30 minutes.

After 61 hours of operation the telescoping section of the power take-off shaft failed due to lack of lubrication. The shaft that was originally supplied with the machine did not have a pressure grease fitting at this location. It was replaced with one that did.

It is recommended that the manufacturer supply, as standard equipment, a power take-off shaft with an accessible grease fitting.

POWER REQUIREMENTS

Average power take-off requirement for the Kuhn FC300 was 36 hp (27 kW) and peak power take off requirement was 49 hp (37 kW). Average drawbar power at 8.0 mph (13 km/h) was 11 hp (9 kW). A tractor with a power take-off rating of 75 hp (56 kW), would have sufficient power to operate the FC300 in typical prairie conditions.

OPERATOR SAFETY

The FC300 was safe to operate and service providing common sense was used and the manufacturer's recommendations were followed.

OPERATOR'S MANUAL

The operator's manual was concise, clearly written and contained useful information on operation, maintenance and safety.

MECHANICAL HISTORY

TABLE 2 outlines the mechanical history of the FC300 during the 178 hour test while mowing 925 acres (370 ha) of crop.

TABLE 2. Mechanical History

ITEM	HOURS	EQUIVALENT FIELD AREA	
		ac	(ha)
-- the telescoping section of the power-take-off shaft failed and was replaced at:	61	317	(126)
-- the cutting knives were dull and replaced at:	20, 61, 89, 131, 162	104 299 690 850	(42) (120) (276) (340)

Discussion of Mechanical History: The telescoping section failed due to a lack of proper lubrication. It was replaced with a shaft which had a more accessible grease fitting. It is recommended that a power take-off shaft with an accessible grease fitting be supplied as standard equipment.

APPENDIX I			
SPECIFICATIONS:			
MAKE:	Kuhn		
MODEL:	FC300		
SERIAL NUMBER:	0303		
HEADER:			
-- width of cut	9.75 ft	(2.9 m)	
-- cutting height	3.3 to 13.9 in	(85 to 355 mm)	
-- diameter of cutting disc	24 in	(605 mm)	
-- knife length	4.2 in	(106 mm)	
-- number of discs	6		
-- knives per disc	2		
-- disc speed	2600 rpm		
CONDITIONING ROTOR:			
-- number	1		
-- material	steel/steel	ingers	
-- length	7.3 ft	(2.2 m)	
-- diameter	extended - 20.9 in	(530 mm)	
-- speed	810 or 1000 rpm		
OVERALL DIMENSIONS:			
	<u>Field Position</u>	<u>Transport Position</u>	
-- length	13.8 ft (4.2 m)	14.4 ft (4.3 m)	
-- width	14.4 ft (4.3 m)	9.8 ft (3.0 m)	
-- height	4.0 ft (1.2 m)	4.7 ft (1.4 m)	
WEIGHT:			
-- left wheel	595 lb (270 kg)	1362 lb (618 kg)	
-- right wheel	1539 lb (698 kg)	855 lb (388 kg)	
-- hitch	<u>952 lb (432 kg)</u>	<u>869 lb (394 kg)</u>	
Total Weight:	3086 lb (1400 kg)	3086 lb (1400 kg)	
TIRES:			
-- number/size	Two/P205-75R14		
SERVICING:			
-- grease fittings	11		
-- gear boxes	3		
-- belts	3		

APPENDIX II	
MACHINE RATINGS	
The following rating scale is used in PAMI Evaluation Reports:	
Excellent	Fair
Very Good	Poor
Good	Unsatisfactory

SUMMARY CHART

KUHN FC300 MOWER CONDITIONER

RETAIL PRICE	(October 1985, \$17,061 f.o.b. Portage la Prairie, Man.)
RATE OF WORK	Very Good ; average speed 8 mph (13 km/h)
QUALITY OF WORK	Excellent performance of cutting discs; very good conditioning.
EASE OF OPERATION	Easy to operate, adjust and maintain.
POWER REQUIREMENTS	75 hp (56 kW) 540 or 1000 rpm power-take-off required.
OPERATOR SAFETY	Very Good
OPERATOR'S MANUAL	Very Good
MECHANICAL HISTORY	One minor mechanical problem.



**ALBERTA
FARM
MACHINERY
RESEARCH
CENTRE**

3000 College Drive South
Lethbridge, Alberta, Canada T1K 1L6
Telephone: (403) 329-1212
FAX: (403) 329-5562
<http://www.agric.gov.ab.ca/navigation/engineering/afmrc/index.html>

Prairie Agricultural Machinery Institute

Head Office: P.O. Box 1900, Humboldt, Saskatchewan, Canada S0K 2A0
Telephone: (306) 682-2555

Test Stations:
P.O. Box 1060
Portage la Prairie, Manitoba, Canada R1N 3C5
Telephone: (204) 239-5445
Fax: (204) 239-7124

P.O. Box 1150
Humboldt, Saskatchewan, Canada S0K 2A0
Telephone: (306) 682-5033
Fax: (306) 682-5080