

Evaluation Report

498

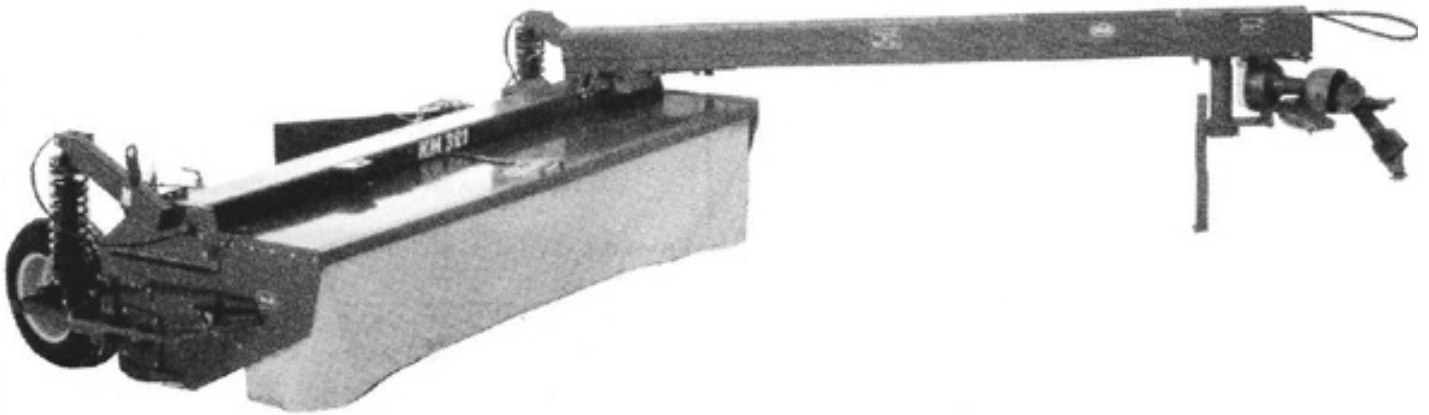

Vicon KM 321 Mower Conditioner

A Co-operative Program Between



ALBERTA
FARM
MACHINERY
RESEARCH
CENTRE



PRAIRIE AGRICULTURAL MACHINERY INSTITUTE

VICON KM 321 MOWER CONDITIONER

MANUFACTURER:

Vicon B.V.
Nieuw Vennepe, Holland

DISTRIBUTOR:

Vicon Wheat-Belt
6423 30th St. S.E.
Calgary, Alberta
T2C 1R4

RETAIL PRICE: \$17,528.00 (April, 1986 f.o.b. Portage la Prairie, Manitoba)

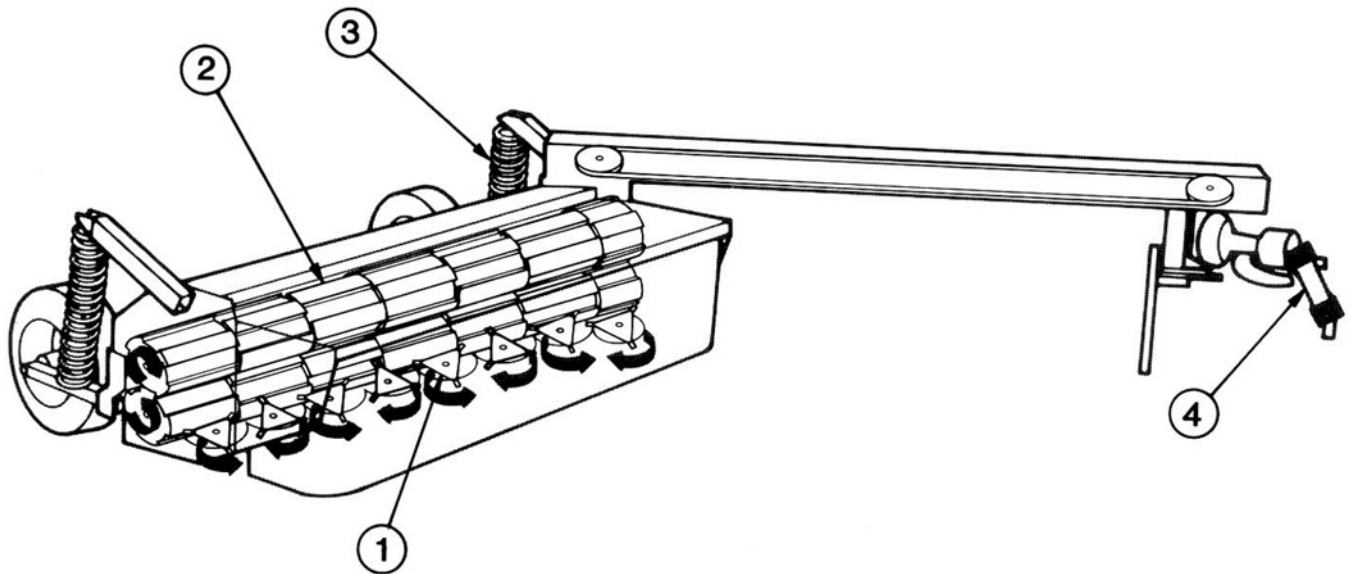

FIGURE 1. Vicon KM 321 Mower Conditioner: (1) Rotary Cutting Discs, (2) Conditioning Rotors, (3) Flotation Springs, (4) Power Take-Off.

SUMMARY

Quality of Work: Performance of the cutting discs was excellent even when cutting damp or fine stemmed crops.

Performance of the conditioning rollers was very good in most crops. In very light crops some material did not pass through the conditioning rollers. Windrow formation was very good.

Rate of Work: The average continuous ground speed for the Vicon KM321 was 8 mph (13 km/h). Field speed was limited by field roughness and the ability of the operator. In smooth fields ground speeds up to 18 mph (29 km/h) were attained.

Average continuous workrate was 9 acres/h (3.6 ha/h).

Ease of Operation and Adjustment: The ease of operation and maintenance was very good. Changing of a complete set of knives took 1-1/2 hours. Daily service and lubrication took 1/2 hour.

Operator Safety: One safety hazard was apparent.

Operator's Manual: The operator's manual was very good.

Mechanical History: One minor mechanical problem occurred during the test.

RECOMMENDATIONS

It is recommended that the manufacturer consider:

1. Strengthening the right drawpole limiting bracket.
2. Providing a more positive locking device to hold the machine in the raised position.
3. Installing a "Slow Moving Vehicle" emblem.

Station Manager: G.M. Omichinski

Project Engineer: C.W. Chapman

THE MANUFACTURER STATES THAT

With regard to the recommendation:

1. The right hand drawbar stop has been strengthened to provide a stop with sufficient strength when the drawbar hydraulic swing cylinder is used.
2. The machine is normally held in the raised position by the hydraulic valve of the tractor. For safety in transport, shut-off valves are provided at each hydraulic cylinder on the mower to protect against accidental lowering by the operator or due to the failure of a hydraulic hose or connection.

The lock valves are much more convenient to use than a clamp type stop that can be placed over the cylinder rod and as a result there is greater tendency for the operator to use them properly.

These valves are NOT to be used in a safety lock-up for working under the machine. The machine should be blocked at each end of the cutterbar if it is necessary to work under it. This information will be added to the Operator's Manual in a more explicit way.

3. When the mower is hitched to a tractor the SMV emblem on the tractor is easily visible, however, we will investigate adding the SMV emblem, or a mount for it, to the units.

MANUFACTURER'S ADDITIONAL COMMENTS

1. After a run-in period of 45 hours, the daily power band belt tension check, can be replaced by a check every 25 hours.
2. A 3.9 m (13 ft) centre pivot mower conditioner will be available in 1987.

GENERAL DESCRIPTION

The Vicon KM321 is a pulltype, 1000 rpm power-take-off driven mower conditioner. The rigid cutting platform uses eight horizontal rotary cutting discs, each with three swinging knives. Two intermeshing nylon conditioning rollers crimp the crop. Adjustable shields form a windrow.

Detailed specifications are given in APPENDIX I and FIGURE 1 shows the location of the major components.

SCOPE OF TEST

The Vicon KM321 was operated in the crops shown in TABLE 1 for 228 hours while harvesting 1219 acres (493 ha).

It was evaluated for quality of work, rate of work, ease of operation, power requirements, operator safety, and suitability of the operator's manual.

TABLE 1. Operating Conditions

CROP	HOURS	EQUIVALENT FIELD AREA	
		ac	(ha)
Alfalfa	74	427	(173)
Mixed Hay	82	460	(186)
Heavy Grass	55	260	(105)
Alfalfa/Grass	13	55	(22)
Oats/Grass	4	17	(7)
Total:	228	1219	(493)

RESULTS AND DISCUSSION

QUALITY OF WORK

Windrow Formation: The Vicon KM321 produced good quality windrows in most crops, as shown in FIGURE 2 and FIGURE 3. Windrow formation was controlled by two adjustable side shields and a canvas top baffle. In some very light crops, and at low forward speeds, some crops failed to clear the cutting discs and enter the conditioning rollers. This resulted in scattered windrows. Higher forward speed resulted in better windrow formation in light crops.

The centre delivery and swivel hitch allowed a continuous windrow to be formed around corners.



FIGURE 2. Windrow Formation in Heavy Crop.



FIGURE 3. Windrow Formation in Light Crop.

Cutting Ability: Cutting ability of the 3 knife rotary discs was excellent in all crops. Fine stemmed or damp crops did not affect cutting ability.

Forward speed did not affect cutting ability, even in heavy crops. Speed was limited by field roughness.

Stubble: The Vicon KM321 produced ideal stubble in most crops. In damp or fine stemmed crops, irregular or ragged stubble was produced when the KM321 was operated with dull knives.

Floatation: Two adjustable springs, located between the main frame of the mower conditioner and the ground wheels, provide floatation. Two adjustable skid shoes allow the cutting discs to follow ground contours.

Floatation of the KM321 was very good in all field conditions.

Conditioner Performance: The Vicon KM321 was equipped with two nylon conditioning rollers, with an offset intermeshing design. Roller clearance could be set with an adjusting bolt and locking nut. Roller pressure was attained with two coil springs and was adjusted with a bolt and lock nut.

Conditioner performance was very good in most crop conditions. In very light crops some material would fall below the lower conditioning roller and not be conditioned. This resulted in the formation of scattered windrows.

The purpose of a conditioner is to reduce curing time, by crimping the plants stems. This also results in more uniform drying.

FIGURE 4 compares the effect of conditioning of the Vicon KM321 with a 18 ft (5.4 m) windrower without a conditioner. The use of a conditioner will likely permit baling one-half to one day earlier.

Much variation in drying time can be expected due to weather conditions at the time of curing.

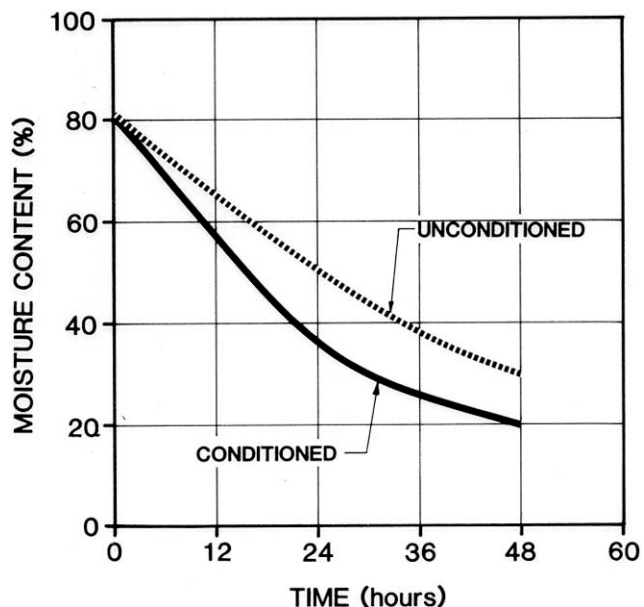

FIGURE 4. The effect of conditioning in alfalfa 3.5 ton/acre (7.8 t/ha).

Leaf Loss: Leaf loss from the Vicon KM321 was negligible.

The uniform drying of the windrow which resulted from the conditioning of the crop, also reduces leaf loss in baling.

RATE OF WORK

The average continuous field speed was 8 mph (13 km/h) and the average continuous work rate was 9 acres/h (3.6 ha/h).

Average daily work rates are lower than continuous work rates because continuous rates do not account for time due to turning, and other field irregularities.

A peak ground speed of 18 mph (29 km/h) was measured in a 3.5 ton/acre (7.8 t/ha) crop of alfalfa.

EASE OF OPERATION

Hitching: The Vicon KM321 was equipped with a swivel hitch which was attached to the lower lift arms of a Category II or

Category III three point hitch. Two chains limited the travel of the lift arms and were attached between the hitch pins and the top link mounting pin.

Controls: The mower conditioner was lifted by the tractor hydraulics through two cylinders which were integral with the floatation springs. Valves on each cylinder trapped hydraulic fluid in the cylinders to hold the mower conditioner in the raised position.

Transporting: The Vicon KM321 was transported by retracting the drawpole locking pin by means of a rope from the tractor seat, moving the drawpole to the right and engaging the locking pin in the transport position.

The Vicon KM321 was also tested with a remote cylinder to replace the manual locking pin. A second pair of remote tractor hydraulics was required. The remote cylinder allowed the operator to change from field to transport position using the tractor hydraulics.

During the test the right stop bracket, which limits the position of the drawpole in the transport position, bent. It is recommended the manufacturer strengthen the bracket.

The Vicon KM321 transported well at all tractor speeds and had adequate ground clearance,

The Vicon KM321 was not equipped with a "Slow Moving Vehicle" emblem. It is recommended that the manufacturer consider installing one.

Adjustments: Adjustments of the conditioning roller clearance and pressure was easy. The conditioning roller speed was not adjustable.

Floatation springs were easily adjusted by fully raising the mower conditioner to unload the springs and repositioning the springs collars.

Changing or reversing the knives took an operator 1-1/2 hours for a complete set of knives. It was necessary to raise the mower conditioner, remove the front shield, and clean dirt and crop residue from the cutter bar. Wrenches for changing the knives were supplied with the machine. The use of a pneumatic impact wrench rendered the change over easier.

It was necessary to check and adjust the main drive belt tension before each operation. This took only a few minutes each day.

Lubrication: The Vicon KM321 was equipped with six pressure grease fittings which required daily lubrication. Several points required daily oiling.

Four gear boxes required weekly checking and a seasonal oil change.

To check the oil level in the cutter bar, it was necessary to elevate one side of the machine. It was easiest to do this in the evening and check the level the next morning. Complete lubrication and inspection took approximately 30 minutes.

POWER REQUIREMENTS

Average power take-off requirement for the Vicon KM321 was 38 hp (29 kW) and peak power take off requirement was 48 hp (36 kW). Average drawbar power at 8.0 mph (13 km/h) was 12 hp (9 kW). A tractor with a power take-off rating of 75 hp (56 kW), and equipped with a 1000 rpm PTO and a Category [Three-point hitch would be sufficient to operate the KM321 in typical prairie conditions.

OPERATOR SAFETY

The Vicon KM321 was equipped with hydraulic valves on each lift cylinder which, when closed trapped hydraulic fluid in the cylinders to hold the mower in the raised position. Accidental opening of the valves could allow the mower to drop and present a safety hazard. It is recommended that the manufacturer consider a more positive locking device to hold the machine in the raised position.

Otherwise the KM321 was safe to operate and service providing common sense was used and the manufacturer's recommendations were followed.

OPERATOR'S MANUAL

The operator's manual was concise, clearly written and contained useful information on operation, maintenance and safety.

MECHANICAL HISTORY

TABLE 2 outlines the mechanical history of the KM321 during the 228 hour test while mowing 1219 acres (493 ha) of crop.

TABLE 2. Mechanical History

ITEM	HOURS	EQUIVALENT FIELD AREA	
		ac	(ha)
— the right drawpole stop bent and was repaired at:	beginning of the test		
— the cutting knives were dull and replaced at:	25.48, 100.147, 179.228	129,241 631.779 1056.1219	(52.96) (252.311) (422.493)

APPENDIX I

SPECIFICATIONS:

MAKE: Vicon

MODEL: KM 321

SERIAL NUMBER: 29006 01080

HEADER:

-- width of cut	10.5 ft	(3.2 m)
-- cutting height	2 to 5.5 in	(50 to 140 mm)
-- diameter of cutting disc	21 in	(530 mm)
-- knife length	4.7 in	(120 mm)
-- number of discs	8	
-- knives per disc	3	
-- disc speed	3000 rpm	

CONDITIONING ROLLERS:

-- number	2	
-- material	nylon	
-- length:		
-- lower	9.8 ft	(3.0 m)
-- upper	9.4 ft	(28 m)
-- diameter	9.1 in	(230 mm)
-- speed	700 or 1000	
-- roller pressure	adjustable spring	

OVERALL DIMENSIONS:

	Field Position	Transport Position
-- length	16.1 ft (4.9 m)	15.4 ft (4.7 m)
-- width	15.8 ft (4.8 m)	11.2 ft (3.4 m)
-- height	3.8 ft (1.2 m)	5.8 ft (18 m)

WEIGHT:

- left wheel	983 lb (446 kg)	1702 lb (772 kg)
-- right wheel	1671 lb (758 kg)	1018 lb (462 kg)
-- hitch	1155 lb (524 kg)	1089 lb (494 kg)
Total Weight:	3809 lb (1728 kg)	3809 lb (1728 kg)

TIRES:

-- number/size	Two/10.0/75 x 15.3.6 ply
----------------	--------------------------

SERVICING:

-- grease fittings
-- gear boxes
- belts

APPENDIX II

MACHINE RATINGS

The following rating scale is used in PAMI Evaluation Reports:

Excellent	Fair
Very Good	Poor
Good	Unsatisfactory

SUMMARY CHART

VICON KM 321 MOWER CONDITIONER

RETAIL PRICE	(October 1985, \$17,528 f.o.b. Portage la Prairie, MB)
RATE OF WORK	Very Good ; average speed 8 mph (13 km/h)
QUALITY OF WORK	Excellent performance of cutting discs; very good conditioning in most crops.
EASE OF OPERATION	Easy to operate, adjust and maintain.
POWER REQUIREMENTS	75 hp (56 kW) 3-point hitch, 1000 rpm power-take-off required.
OPERATOR SAFETY	One safety hazard, otherwise very good .
OPERATOR'S MANUAL	Very Good
MECHANICAL HISTORY	One minor mechanical problem.



**ALBERTA
FARM
MACHINERY
RESEARCH
CENTRE**

3000 College Drive South
Lethbridge, Alberta, Canada T1K 1L6
Telephone: (403) 329-1212
FAX: (403) 329-5562
<http://www.agric.gov.ab.ca/navigation/engineering/afmrc/index.html>

Prairie Agricultural Machinery Institute

Head Office: P.O. Box 1900, Humboldt, Saskatchewan, Canada S0K 2A0
Telephone: (306) 682-2555

Test Stations:
P.O. Box 1060
Portage la Prairie, Manitoba, Canada R1N 3C5
Telephone: (204) 239-5445
Fax: (204) 239-7124

P.O. Box 1150
Humboldt, Saskatchewan, Canada S0K 2A0
Telephone: (306) 682-5033
Fax: (306) 682-5080