

# Evaluation Report 292



## Leon 8200 (12.3 m) Rod Weeder

A Co-operative Program Between



ALBERTA  
FARM  
MACHINERY  
RESEARCH  
CENTRE



PRAIRIE AGRICULTURAL MACHINERY INSTITUTE

## LEON 8200 ROD WEEDER

### MANUFACTURER:

Anderson Industries Ltd.  
P.O. Box 40  
Southey, Saskatchewan  
S0G 4P0

### DISTRIBUTOR:

Leon's Manufacturing Co. Ltd.  
135 York Road East  
Yorkton, Saskatchewan  
S3N 3N6

### SUMMARY AND CONCLUSIONS

The overall functional performance of the Leon 8200 rod weeder was *very good* for light tillage operations such as seedbed preparation and secondary summerfallow. Performance was reduced by excessive penetration of the rod drive shanks.

The spring-trip rod shanks could lift 250 mm (10 in), and the spring cushioned cultivator shanks could lift 260 mm (10.2 in) to clear stones. No shank damage occurred.

Penetration was *good* in most light tillage operations. The cultivator shanks aided penetration of the rod in firm soils. In hard soils the cultivator shank spacing was insufficient to loosen the soil for adequate rod penetration. The rod drive shanks penetrated 75 mm (3 in) deeper than the rod and produced deep surface furrows. Plugging occurred at the wheel locations in heavy or damp trash. Large quantities of trash accumulated in the mounted harrows in moderate trash conditions. The Leon buried less trash than most cultivators. Sideways skewing occurred only on hillsides. Weed kill was *very good* and depended on tillage depth and moisture conditions. In moist conditions with light trash, the mounted harrows were effective in exposing loosened weeds.

The wings of the Leon 8200 were easily raised and locked into transport position. The transport locks for the centre section wheels were difficult to install or store. The rod shank ground clearance of 180 mm (7 in) and wheel tread of 4.1 m (13.5 ft) caused ground contact on rough roads, and difficult passage on narrow roads. The Leon 8200 towed well at normal transport speeds. The tire loads in transport position with mounted harrows exceeded the Tire and Rim Association maximum load rating for the tires supplied by 89%. The 12.3 m (40.4 ft) wide test machine had a transport height of 4.5 m (14.8 ft) which was slightly less than minimum power line heights for the three prairie provinces. Extreme caution was required to ensure safe passage under power lines.

A hitch jack was provided for easy hitching. A negative hitch load made hitching difficult when the machine was fitted with mounted harrows. Adequate adjustment was provided for both lateral and fore-and-aft levelling.

Average draft for the 12.3 m (40.4 ft) wide test machine with the cultivator shanks, in secondary tillage at 8 km/h (5 mph), varied from 14.8 kN (3330 lb) at 25 mm (1 in) depth to 25.9 kN (5820 lb) at 75 mm (3 in) depth. In secondary tillage with the cultivator shanks removed at 8 km/h (5 mph), average draft varied from 11.1 kN (2500 lb) at 25 mm (1 in) depth to 19.7 kN (4430 lb) at 75 mm (3 in) depth.

In secondary tillage, at 8 km/h (5 mph) and 50 mm (2 in) depth a tractor with 78 kW (101 hp) maximum power take-off rating will have sufficient power reserve to operate the 12.3 m (40.4 ft) wide Leon 8200 with the cultivator shanks. In secondary tillage with the cultivator shanks removed, at the same depth and speed, a 60 kW (78 hp) tractor is needed.

No slow moving vehicle sign was provided with the Leon 8200. The operator's manual was clearly written and well illustrated.

Some mechanical problems occurred during the 138 hours of field operation. A wing lift cylinder yoke broke, the hitch jack was damaged, and a rod drive pillow block failed.

### RETAIL PRICE:

\$12,180.00 (December, 1982, f.o.b. Humboldt, 12.3 m width, with optional mounted finishing harrows and cultivator shanks complete with sweeps.)

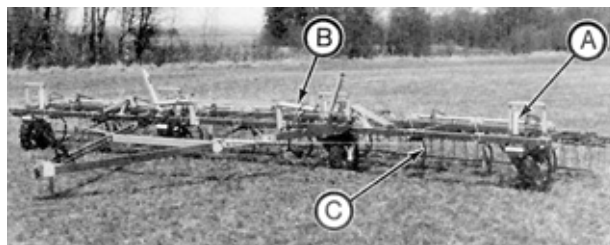

FIGURE 1. Leon 8200 (A) Depth Control Cylinders, (B) Wing Lift Cylinders, (C) Cultivator Shanks.

### RECOMMENDATIONS

It is recommended that the manufacturer consider:

1. Modifications to reduce excessive penetration of the rod drive shanks.
2. Equipping the rod weeder with tires that comply with the Tire and Rim Association load rating.
3. Modifying the rod drive system to prevent possible damage to the rod drive shaft.
4. Modifying the chain guards to allow easy access for removing the rod drive chains for transport.
5. Modifying the depth control transport locks to provide easier installation and storage.
6. Providing a slow moving vehicle sign mounted in a clearly visible location as standard equipment.
7. Providing an alternate hitch jack location at the rear of the machine to facilitate hitching when mounted harrows are used.
8. Working with the agricultural equipment industry to standardize hydraulic quick couplers and hydraulic hose fitting threads.

Senior Engineer: G. E. Frehlich

Project Technologist: A. R. Boyden

### THE MANUFACTURER STATES THAT

With regard to recommendation number:

1. In view of your findings and comments, we will recommend that the wear rods be set no more than 9 to 13 mm (3/8 to 1/2 in) below the drive boot when working seeded land. However, in all other conditions, the present recommended setting should be maintained to minimize drive boot wear.
2. The tires supplied have been used on our rod weeders for many years without causing problems. In view of your test results, we will look at installing heavier ply tires on the larger machines.
3. The rod drive system was modified on later 1982 machines to provide increased clearance for the rod drive shaft.
4. We recommend that the drive chains be removed for long transport distances only. We feel that removal of two bolts allows easy access to the rod drive chains.
5. New depth control transport locks were introduced on 1982 models.
6. We will ensure the bracket for the slow moving vehicle sign is located to provide full visibility of the sign.
7. An optional rear stand is now available for machines equipped with mounted harrows.
8. Leon's Manufacturing Co. Ltd. will be most happy to work with the agricultural equipment industry to standardize hydraulic quick couplers and hose fittings.

**NOTE:** This report has been prepared using SI units of measurement. A conversion table is given in APPENDIX II.1.

## GENERAL DESCRIPTION

The Leon 8200 is a trailing, flexible rod weeder suitable for light tillage such as seedbed preparation and secondary summerfallow. It is available in five widths as a three-section machine, ranging from 8.5 m (28 ft) to 14.6 m (48 ft). It is also available in three widths as a five-section machine, up to 19.5 m (64 ft). The test machine is a 12.3 m (40.4 ft) model with a 4.9 m (16 ft) centre frame and two 3.7 m (12.2 ft) wings. The round, ground driven rod, is in seven sections, supported by ten spring trip shanks. The rods for each frame section are coupled with rigid connectors. The 11 optional spring cushioned cultivator shanks are spaced at 1.2 m (3.9 ft) in a single row across the front of the machine.

The centre frame is carried on two wheels, while each wing is supported by a single wheel. Four hydraulic cylinders, connected in series, control tillage depth. Two hydraulic cylinders connected in parallel fold the wings into an upright position. A tractor with dual remote hydraulic controls is needed to operate the Leon 8200.

Detailed specifications are given in APPENDIX I while FIGURE 1 shows the location of major components.

## SCOPE OF TEST

The Leon 8200 was operated in the field conditions shown in TABLE 1 for 138 hours, while tilling about 1251 ha (3090 ac). It was evaluated for quality of work, ease of operation and adjustment, power requirements, safety and suitability of the operator's manual.

The optional cultivator shank assemblies and mounted harrows were used during most of the test.

TABLE 1. Operating Conditions.

FIELD CONDITION	HOURS	AREA (ha)
<i>Soil Type</i>		
— light loam	44	368
— sandy loam	5	43
— loam	62	580
— clay	18	176
— heavy clay	9	84
TOTAL	138	1 251
<i>Stony Phase</i>		
— stone free	19	188
— occasional stones	68	609
— moderately stony	35	292
— very stony	16	162
TOTAL	138	1 251

## RESULTS AND DISCUSSION

### QUALITY OF WORK

**Shank Characteristics:** The Leon 8200 was equipped with adjustable spring trip rod shanks that tripped independently to clear small obstructions. For large obstructions, all the shanks on the frame section tripped together. FIGURE 2 shows the lifting pattern of the shanks when stones or field obstructions were encountered. The maximum lift height of 250 mm (10 in) and the trip settings were adequate for the stony conditions encountered. No shank or rod failures occurred during the test.

The cultivator shanks were equipped with adjustable cushion springs. FIGURE 3 shows the lifting pattern when the cultivator shanks encountered stones or field obstructions. The cultivator shank assemblies performed well. The maximum lift height of 260 mm (10.2 in) and the recommended spring settings were adequate for the stony conditions encountered.

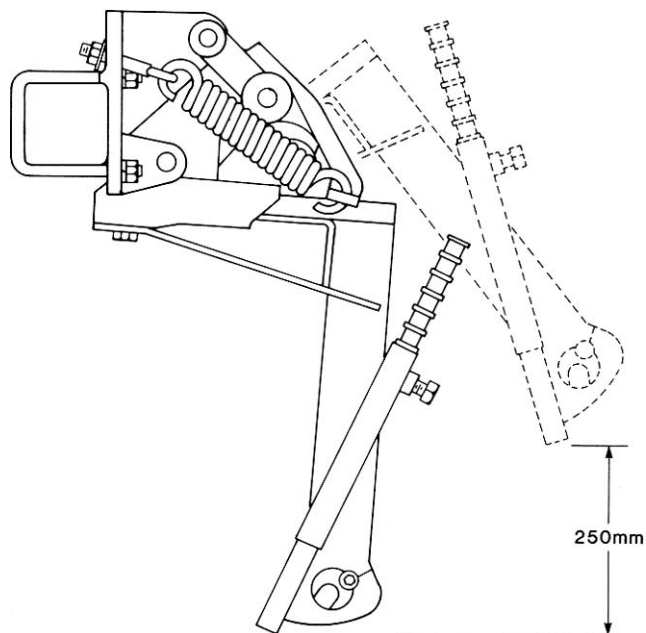

FIGURE 2. Rod Shank Lifting Pattern.

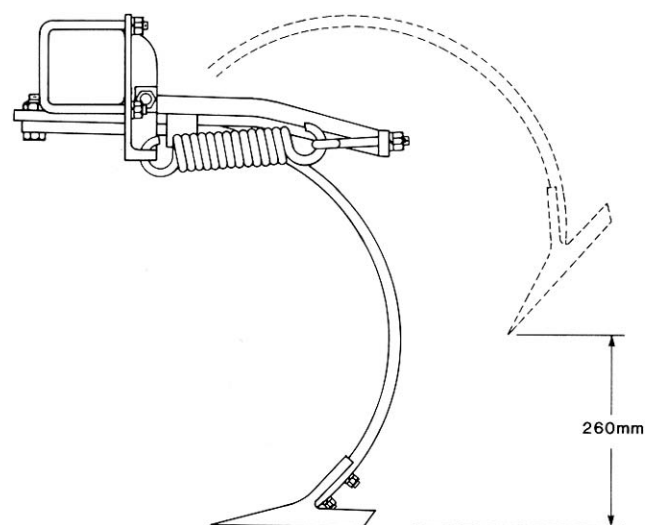

FIGURE 3. Cultivator Shank Lifting Pattern.

**Penetration:** Penetration was good in light tillage operations such as seedbed preparation and secondary summerfallow.

The optional cultivator shanks aided penetration in firm soils. In hard soils, however, the 1.2 m (3.9 ft) shank spacing was insufficient to loosen the soil ahead of the rod, resulting in poor rod penetration and weed misses.

The rod drive shanks penetrated about 75 mm (3 in) deeper than the rod, when the wear rods were properly adjusted. This produced deep furrows behind the rod drive shanks and caused some seedling damage when operating the rod weeder in seeded fields. It is recommended that the manufacturer consider modifications to reduce excessive penetration of the rod drive shanks.

Penetration was uniform across the rod weeder width, provided the frame was properly levelled and the depth control cylinders were kept synchronized. The wheels were adequately sized and positioned to support the rod weeder weight for uniform penetration. In normal secondary tillage the frame remained level with very little twisting of the wing frames.

The Leon 8200 followed gently rolling field contours well, maintaining uniform depth across its width. As with most wing tillage implements, large variations in tillage depth occurred in fields with abrupt contour changes.

**Plugging:** The Leon 8200 cleared trash well in moderate trash conditions. Occasional plugging occurred at the wheel locations in heavy trash conditions (FIGURE 4).

The mounted harrows plugged easily in moderate to heavy trash conditions when set at a steep tine angle. Reducing the tine angle improved trash clearance.

**Trash Burial and Surface Conditions:** The rod drive shanks of the Leon 8200 left deeper furrows than the rod support shanks. These furrows were usually filled in by the finishing harrows resulting in a uniform seedbed (FIGURE 5). The Leon 8200 buried less trash than most cultivators (FIGURE 6).

**Skewing and Stability:** The Leon 8200 was stable and sideways skewing only occurred on hillsides. The location of the rod shanks and cultivator shanks (FIGURE 7) did not impose any side forces on the rod weeder during normal tillage.



FIGURE 4. Plugging at the Wing Wheel Location in Heavy Trash.



FIGURE 5. Typical Seedbed Preparation With Mounted Harrows and With Cultivator Shanks Removed.



FIGURE 6. Typical Secondary Tillage With Mounted Harrows and Cultivator Shanks.

**Weed Kill:** Weed kill was very good in soft soils and good in firm soils when the cultivator shanks were used to aid penetration. Many weed misses occurred in hard soils. As with most rod weeders, a shallow working depth increased soil disturbance and produced a better weed kill. Some weeds in moist conditions were able to pass over the rod with little root disturbance. The mounted, harrows were effective in exposing these weeds when set at a steep tine angle. In moderate to heavy trash conditions, the reduced tine angle required to clear trash was less effective in exposing weeds.

## EASE OF OPERATION AND ADJUSTMENT

**Transporting:** The Leon 8200 was easily placed into transport position in less than five minutes using the hydraulic wing lift system (FIGURE 8). The retaining straps between the hydraulic cylinders had to be replaced with shorter straps to provide easy installation of the transport lock pins. The transport locks for the depth control wheels on the centre section (FIGURE 9) were large and difficult to install or store when not in use. It is recommended that the manufacturer modify these transport locks to provide easier installation and storage.

For high transport speeds or long distances, removal of the centre rod drive chain was recommended. The chain guard made access for removing or installing the chain difficult. It is recommended that the manufacturer modify the chain guards to allow easy access to the rod drive chains.

Transport width was 6.7 m (22 ft) wide while transport height was 4.5 m (14.8 ft). Care was needed when transporting on public roads, through gates, over bridges, and beneath power and telephone lines.,

The Leon 8200 towed well without sway at normal transport speeds. The rod shank ground clearance of 180 mm (7 in) and a wheel tread of 4.1 m (13.5 ft) caused some shank contact with the ground on rough roads, and difficult passage on narrow roads.

**Hitching:** The hitch jack and the supported hitch link of the Leon 8200 made one-man hitching easy. However, when mounted harrows were used, the negative hitch weight made hitching difficult. It is recommended that an alternate location for the hitch jack be provided at the rear of the rod weeder to facilitate hitching when mounted harrows are used.

The hitch height could be easily adjusted 200 mm (8 in) in five increments. This range was adequate to allow fore-and-aft frame leveling with all tractors used during the test.

**Maneuverability:** The hitch frame of the Leon 8200 was narrow, permitting normal turns with the two wheel drive tractors used during the test. However, the hitch jack interfered with the wheels of a four wheel drive tractor during a normal turn.

**Frame Levelling:** Adequate lateral levelling for the centre and wing sections was provided by adjusting the bolts at the top frame member of the depth control cylinders. However, lowering the wing sections too far caused damage to the rod drive shafts when working at greater depths (see "Durability Results").

**Depth of Tillage:** Tillage depth was controlled with four hydraulic cylinders connected in series. A hydraulic stop valve on one cylinder provided adequate depth settings. As is common with series hydraulic systems, to maintain the centre and wing sections at the same depth, periodic synchronization of the cylinders, by completely extending them, was necessary.

**Sweep Installation:** It took one man about one-half hour to remove and replace the 11 sweeps on the Leon 8200. Adequate ground clearance made sweep bolt removal easy.

**Rod Shank Wear Rod Adjustment:** The Leon 8200 rod shanks were equipped with adjustable wear rods that required frequent adjustment in abrasive soils. The wear rods on the rod drive shanks were difficult to adjust due to rod binding and limited access to the top of the rods (FIGURE 10).

**Shank Installation:** The 11 cultivator shanks could easily be installed or removed in about one-half hour. Each shank was attached to the shank assembly with one bolt.

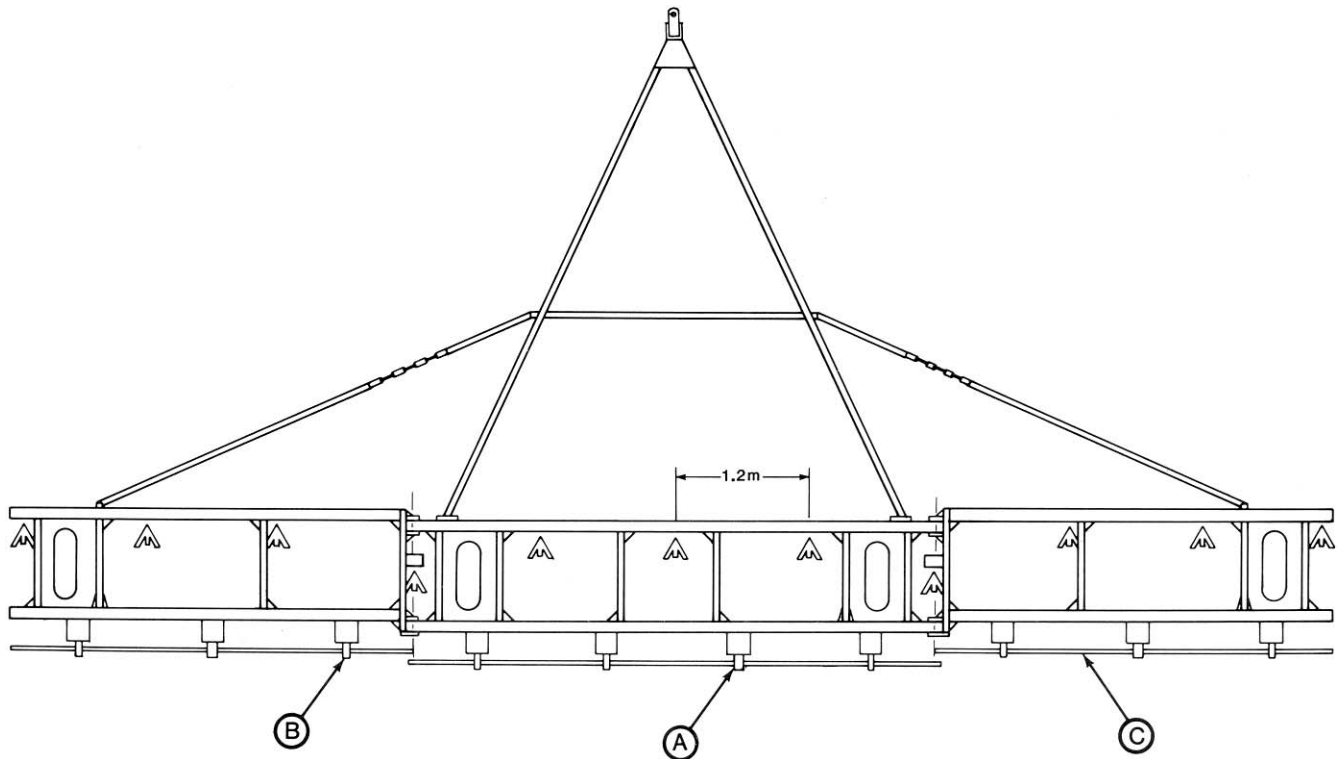

FIGURE 7. Shank Pattern (A) Rod Drive Shanks, (B) Rod Support Shanks, (C) Rod.

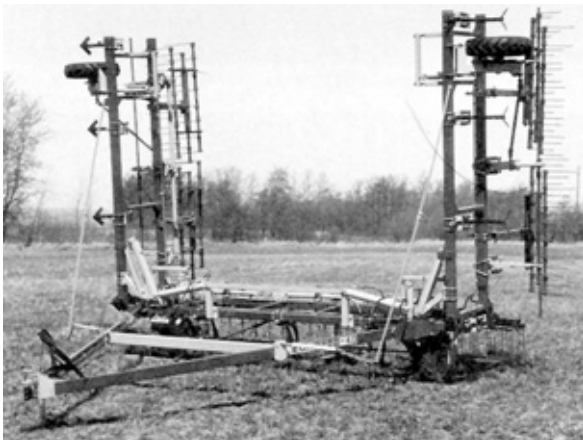

FIGURE 8. Transport Position.

**POWER REQUIREMENTS**

**Draft Characteristics:** FIGURE 11 shows draft requirements for rod weeders in typical secondary tillage at a speed of 8 km/h (5 mph). This figure gives average requirements based on tests of six rod weeders in several different field conditions. Attempting to compare draft requirements of different makes of rod weeders is unrealistic. Variation in soil conditions affect draft much more than variation in machine make, usually making it impossible to measure any significant draft difference between different makes of rod weeders.

In secondary tillage when equipped with 11 cultivator shanks equally spaced in a single row at the front of the machine, average draft per metre of width at 8 km/h (5 mph), varied from 1.2 kN/m (82 lb/ft) at 25 mm (1 in) depth to 2.1 kN/m (144 lb/ft) at 75 mm (3 in) depth. For the 12.3 m (40.4 ft) wide test machine, this corresponds to a total draft ranging from about 14.8 to 25.9 kN (3330 to 5820 lb).

In secondary tillage with the cultivator shanks removed, the average draft per metre of width at 8 km/h (5 mph), varied from 0.9 kN/m (62 lb/ft) at 25 mm (1 in) depth to 1.6 kN/m (110 lb/ft) at 75 mm (3 in) depth. For the 12.3 m (40.4 ft) wide test machine this corresponds to a total draft ranging from about 11.1 to 19.7 kN (2500 to 4430 lb).



FIGURE 9. Transport Depth Control Lock.

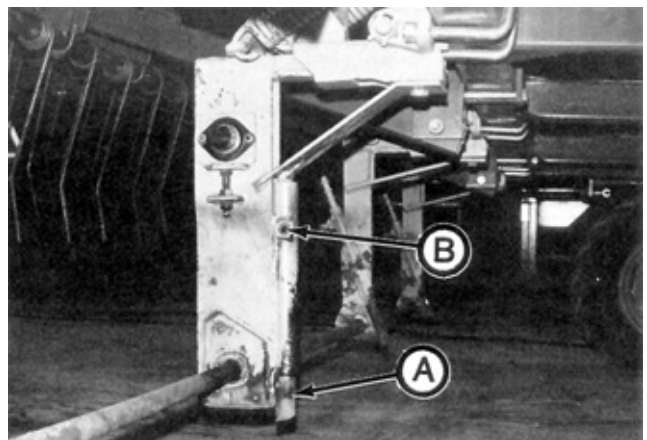

FIGURE 10. Rod Drive Shank (A) Wear Rod, (B) Set Screw Adjustment.

**Tractor Size:** TABLES 2 and 3 show tractor sizes needed to operate the 12.3 m (40.4 ft) Leon 8200 in secondary tillage with and without cultivator shanks, respectively. Tractor sizes have been adjusted to include tractive efficiency and represent a tractor operating at 80% of maximum power on a level field. The sizes presented in the tables are the maximum power take-off rating, as determined by Nebraska or as presented by the tractor manufacturer. Selected tractor sizes will have ample power reserve to operate the Leon 8200 in the stated conditions.

Tractor size may be determined by selecting the desired tillage depth and speed from the appropriate table. For example, in secondary tillage at 50 mm (2 in) depth and 8 km/h (5 mph) a 78 kW (101 hp) tractor is needed to operate the Leon 8200. In secondary tillage with the cultivator shanks removed, at the same depth and speed, a 60 kW (78 hp) tractor is needed.

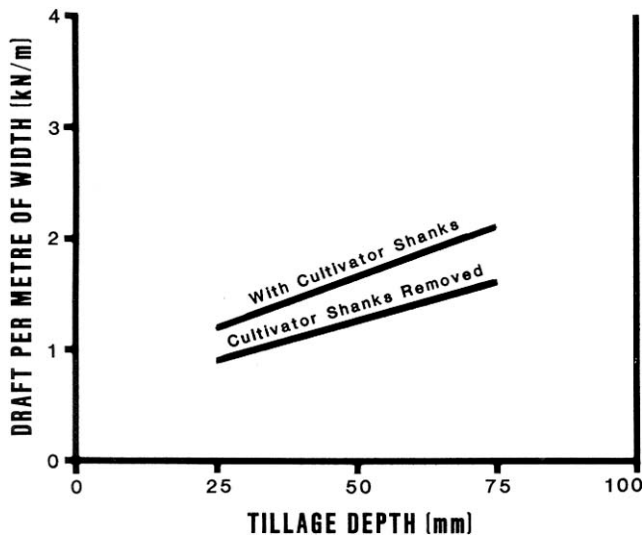

FIGURE 11. Average Draft Requirements for Rod Weeders in Secondary Tillage at 8 km/h.

TABLE 2. Tractor Size (Maximum Power Take-Off Rating, kW) to Operate the 12.3 m Wide Leon 8200 in Secondary Tillage with Cultivator Shanks.

DEPTH (mm)	SPEED (km/h)					
	7	8	9	10	11	12
25	47	56	65	75	86	97
50	66	78	90	103	116	130
75	86	100	115	131	147	164

TABLE 3. Tractor Size (Maximum Power Take-Off Rating, kW) to Operate the 12.3 m Wide Leon 8200 in Secondary Tillage with the Cultivator Shanks Removed.

DEPTH (mm)	SPEED (km/h)					
	7	8	9	10	11	12
25	36	42	49	57	64	72
50	51	60	69	79	89	99
75	67	78	89	101	113	125

### OPERATOR SAFETY

Extreme caution is needed in transporting most folding implements to avoid contacting power lines. Minimum power line heights vary in the three prairie provinces. In Saskatchewan the energized line may be as low as 5.2 m (17 ft) over farmland or over secondary roads. In Alberta and Manitoba, the neutral ground wire may be as low as 4.8 m (15.8 ft) over farmland. In all three provinces, lines in farmyards may be as low as 4.6 m (15 ft).

Transport height of the 12.3 m (40.4 ft) wide test machine was 4.5 m (14.8 ft), which required extreme caution to ensure safe passage under power lines. The legal responsibility for safe passage under utility lines rests with the machinery operator and not with the power utility or the machinery manufacturer. All provinces have regulations governing maximum permissible equipment heights on various types of public roads. If height limits are exceeded, the operator must contact power and telephone utilities before moving.

The Leon 8200 was 6.7 m (22 ft) wide in transport position. This necessitated caution when transporting on public roads, over bridges and through gates.

A slow moving vehicle sign was not provided. A mounting bracket was supplied but did not provide an unobstructed view of the sign. It is recommended that the manufacturer supply a slow moving vehicle sign mounted in a clearly visible location as standard equipment.

Transport locks were provided for the centre section depth control wheels and the wings.

The Leon 8200 towed well at speeds up to 32 km/h (20 mph). The centre section tire loads in transport position with mounted harrows, exceeded the Tire and Rim Association maximum rating for 7.6L x 15, 6 ply tires by 89%. This tire load was considered unsafe and hazardous, especially at high transport speeds. It is recommended that the rod weeder be equipped with tires having suitable load ratings.

### STANDARDIZATION

**Hydraulics:** During the test, considerable difficulty was encountered due to differences in hydraulic couplers on various tractors. The difficulty was in the lack of standardization both in couplers and in hose threads. More standardization is needed in this area.

### OPERATOR'S MANUAL

The Leon 8200 operator's manual contained information on operation, adjustment, maintenance, and safety. It was clearly written and well illustrated.

### DURABILITY RESULTS

TABLE 4 outlines the mechanical history of the Leon 8200 during 138 hours of field operation while tilling about 1251 ha (3090 ac). The intent of the test was evaluation of functional performance. The following mechanical problems represent those which occurred during functional testing. An extended durability evaluation was not conducted.

TABLE 4. Mechanical History.

ITEM	OPERATING HOURS	EQUIVALENT FIELD AREA (ha)
<b>Shanks:</b> -- The retaining nuts for a drive shank side plate were lost and replaced at	23	210
<b>Hydraulics:</b> -- A wing lift hydraulic cylinder yoke failed and was replaced at	8	77
-- The retaining straps for the wing lift cylinders were replaced with shorter ones at	26	228
<b>Frame:</b> -- The harrow mounting bolts interfered with the rod drive shafts		during the test
-- The hitch jack interfered with the rear tractor wheels and was damaged at	100	877
-- A bearing pillow block on a rod drive failed at	61, 66, 105	551, 595, 922

### DISCUSSION OF MECHANICAL PROBLEMS

**Shanks:** After the retaining nuts were replaced on the drive shank side plate, no further loss occurred. The nuts and bolt heads were very worn by the end of tests.

**Hydraulics:** A wing lift cylinder yoke (FIGURE 12) failed when lifting the wings into transport position.

The retaining straps between the wing lift cylinders were too long to permit easy installation of the wing transport lock pins. Shorter retaining straps were installed and they allowed the wings to be lifted fully against their stops for easy installation of the transport pins.

**Frame:** The rod drive shafts interfered with the harrow mounting bolts when the lateral levelling adjustments exceeded the maximum setting stated in the operator's manual. When set at the maximum setting, the rod drive shaft may contact the rod weeder frame if the rod shanks trip to clear obstructions. It is recommended that the manufacturer modify the rod drive assembly to prevent possible damage to the rod drive shaft.

The hitch jack was damaged by the rear tractor wheel of a large four wheel drive tractor during a normal turn. Damage did not occur with two wheel drive tractors used in the test.

The pillow block for the rod drive shaft failed three times because it was mounted on an uneven surface (FIGURE 14). Shimming the pillow block with washers did not eliminate the problem.

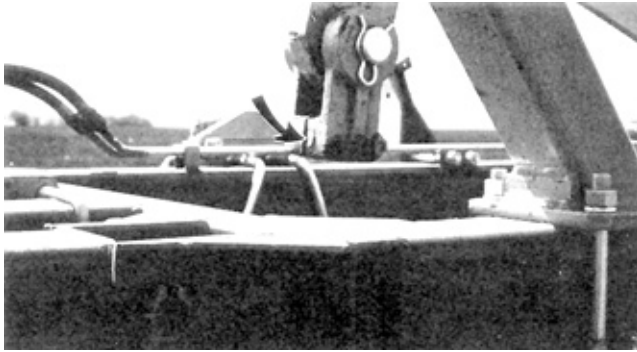

FIGURE 12. Hydraulic Cylinder Yoke Failure.

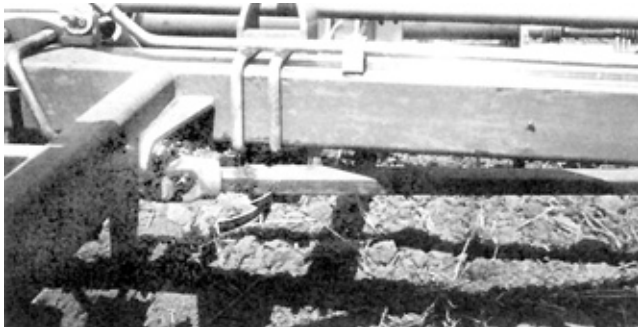

FIGURE 13. Interference of the Frame with the Rod Drive Shaft.

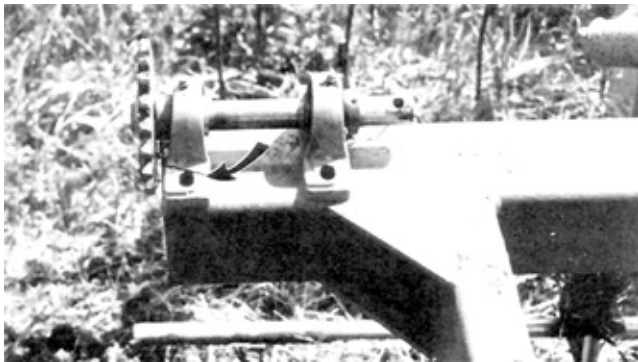

FIGURE 14. Rod Drive Pillow Block Failure.

<b>SHANKS:</b>		
rod shanks		
-- number	10	
-- lateral spacing	1230 mm	
-- trash clearance (frame to rod)	540 mm	
-- drive shank cross-section	165 x 41 mm	
-- non-driven shank cross section	76 x 19 mm	
cultivator shanks		
-- number	11	
-- lateral spacing	1200 mm	
-- trash clearance (frame to sweep tip)	540 mm	
-- shank cross-section	45 x 14 mm	
-- shank stem angle	46°	
-- sweep hole spacing	45 mm	
-- sweep bolt size	3/8 x 1-1/2 in	
<b>HITCH:</b>		
-- vertical adjustment range	200 mm	
<b>DEPTH CONTROL:</b>		
	hydraulic	
<b>FRAME:</b>		
-- cross-section	100 mm, square tubing, 6 mm thick	
<b>TIRES:</b>		
-- centre section	2, 7.6L x 15, 6 ply	
-- wings	2, 7.6L x 15, 6 ply	
<b>NUMBER OF LUBRICATION POINTS.</b>		
	15 grease fittings, daily service	
	8 wheel bearings, bi-yearly service	
<b>HYDRAULIC CYLINDERS:</b>		
-- depth control	1, 89 x 229 mm	
	1, 89 x 203 mm	
	1, 76 x 229 mm	
	1, 76 x 203 mm	
-- wing lift	2, 89 x 610 mm	
<b>WEIGHTS.</b>		
(Without Harrows)	<b>FIELD POSITION</b>	<b>TRANSPORT POSITION</b>
-- right wheel	340 kg	
-- right centre wheels	805 kg	1140 kg
-- left centre wheels	735 kg	1090 kg
-- left wheel	360 kg	
-- hitch	60 kg	70 kg
<b>TOTAL</b>	<b>2300 kg</b>	<b>2300 kg</b>
<b>WEIGHTS:</b>		
(With Mounted Harrows)	<b>FIELD POSITION</b>	<b>TRANSPORT POSITION</b>
-- right wheel	435 kg	
-- right centre wheels	1065 kg	1490 kg
-- left centre wheels	985 kg	1430 kg
-- left wheel	445 kg	
-- hitch	-74 kg	-64 kg
<b>TOTAL</b>	<b>2856 kg</b>	<b>2856 kg</b>
<b>OPTIONAL EQUIPMENT.</b>		
-- width options from 8.5 to 19.5 m		
-- cultivator shank assemblies		
-- mounted finishing harrows		
-- cast bushings		

<b>APPENDIX I</b>		
<b>SPECIFICATIONS</b>		
<b>MAKE:</b> Leon Rod Weeder		
<b>MODEL:</b> 8200		
<b>SERIAL NUMBER:</b> 201-3176		
<b>MANUFACTURER:</b> Anderson Industries Ltd.		
	P.O. Box 40	
	Southey, Saskatchewan	
	S0G 4P0	
<b>DIMENSIONS:</b>	<b>FIELD POSITION</b>	<b>TRANSPORT POSITION</b>
-- width	12,320 mm	6700 mm
-- length	6150 mm	5150 mm
-- height	1660 mm	4500 mm
-- maximum ground clearance	180 mm	180 mm
-- wheel tread	11,360 mm	4060 mm
<b>RODS:</b>		
-- number of rods	7	
-- number of rods to each section		
-- centre section	3	
-- wing sections	2	
-- rod size	29 mm	
-- drive type	ground driven	

<b>APPENDIX II</b>	
<b>MACHINE RATINGS</b>	
The following rating scale is used in Machinery Institute Evaluation Reports:	
(a) excellent	(d) fair
(b) very good	(e) poor
(c) good	(f) unsatisfactory

<b>APPENDIX III</b>	
<b>CONVERSION TABLE</b>	
1 kilometre/hour (km/h)	= 0.6 miles/hour (mph)
1 metre (m)	= 3.3 feet (ft)
1 millimetre (mm)	= 0.04 inches (in)
1 kilogram (kg)	= 2.2 pounds mass (lb)
1 kilowatt (kW)	= 1.3 horsepower (hp)
1 hectare (ha)	= 2.5 acres (ac)
1 kilonewton (kN)	= 220 pounds force (lb)
1 kilonewton/metre (kN/m)	= 70 pounds force/foot (lb/ft)



**ALBERTA  
FARM  
MACHINERY  
RESEARCH  
CENTRE**

3000 College Drive South  
Lethbridge, Alberta, Canada T1K 1L6  
Telephone: (403) 329-1212  
FAX: (403) 329-5562

<http://www.agric.gov.ab.ca/navigation/engineering/afmrc/index.html>

**Prairie Agricultural Machinery Institute**

Head Office: P.O. Box 1900, Humboldt, Saskatchewan, Canada S0K 2A0  
Telephone: (306) 682-2555

Test Stations:

P.O. Box 1060

Portage la Prairie, Manitoba, Canada R1N 3C5

Telephone: (204) 239-5445

Fax: (204) 239-7124

P.O. Box 1150

Humboldt, Saskatchewan, Canada S0K 2A0

Telephone: (306) 682-5033

Fax: (306) 682-5080