

# Evaluation Report 167

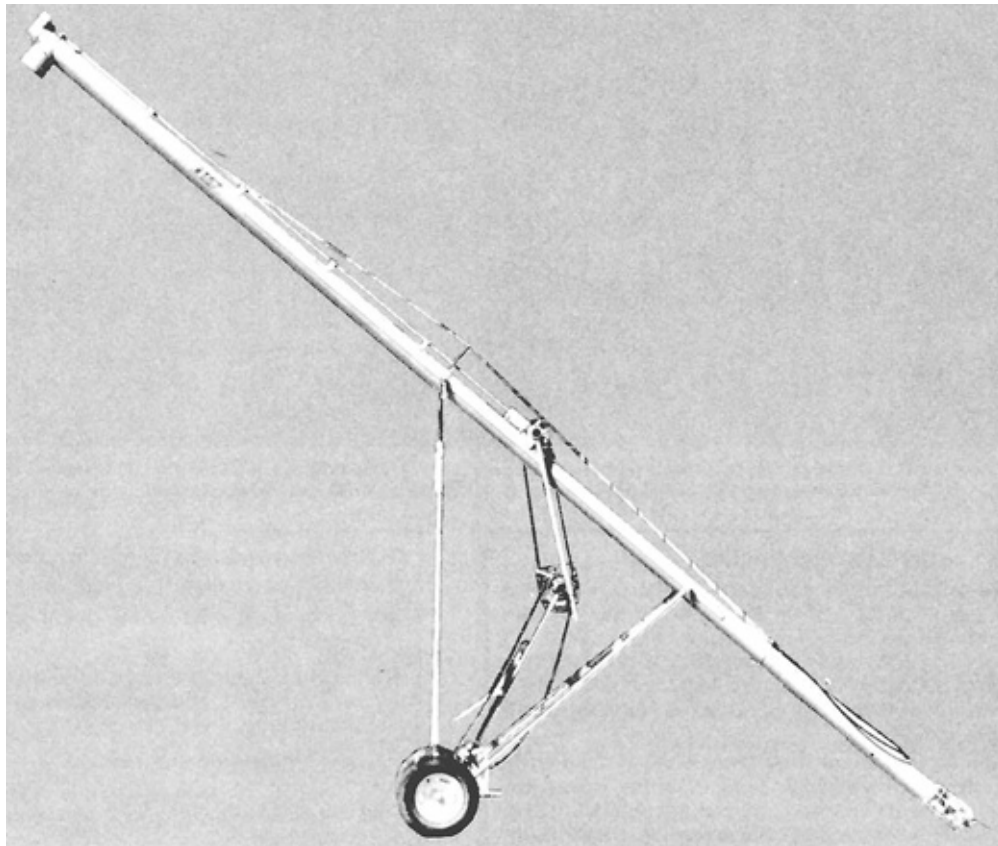

McIntyre 8 x 37 Grain Auger

A Co-operative Program Between



ALBERTA  
FARM  
MACHINERY  
RESEARCH  
CENTRE



PRAIRIE AGRICULTURAL MACHINERY INSTITUTE

# McINTYRE 8 x 37 GRAIN AUGER

## MANUFACTURER AND DISTRIBUTOR

McIntyre Industries Ltd.  
P.O. Box 1749  
Swift Current, Saskatchewan  
S0H 4S8

RETAIL PRICE: \$2,394.00 (April 1981, f.o.b. Swift Current).

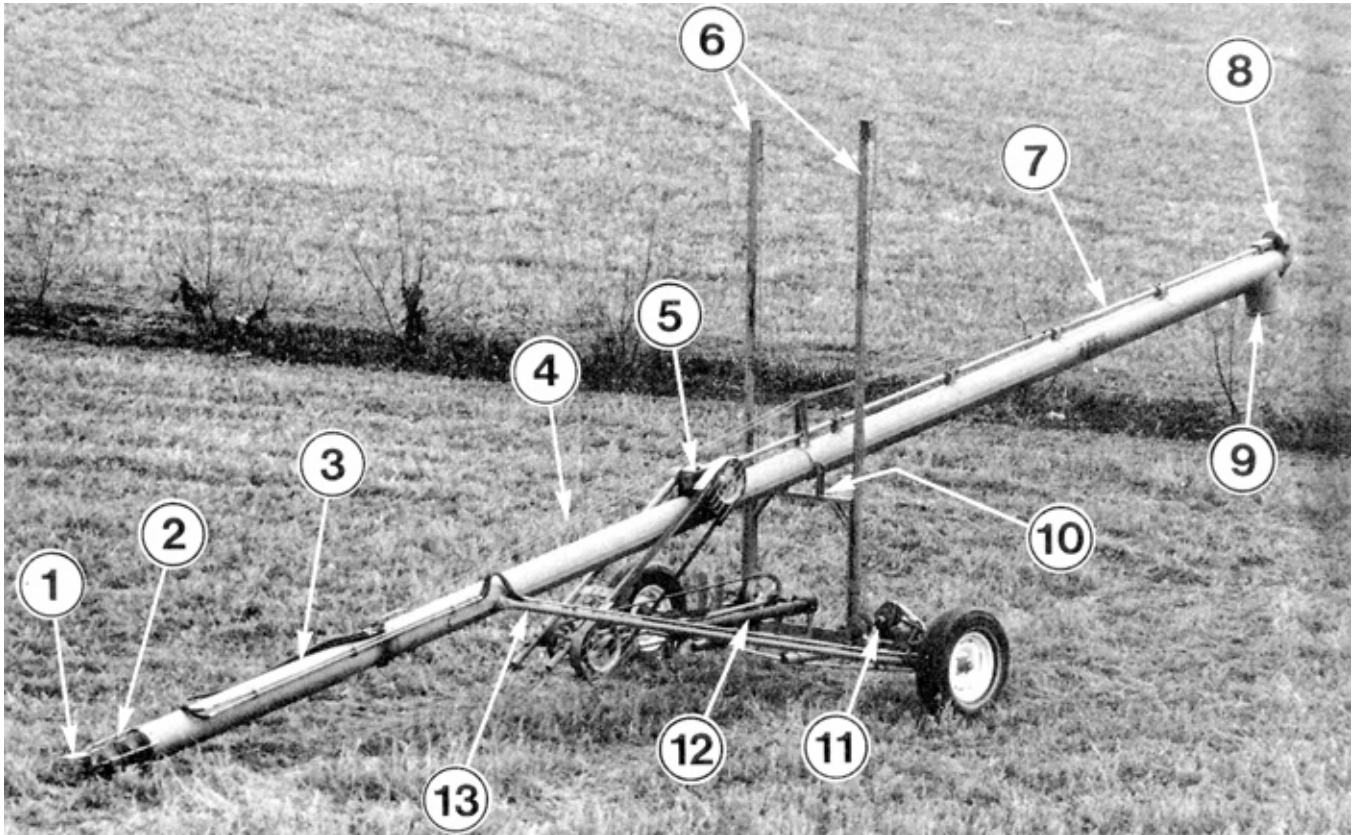

**FIGURE 1.** McIntyre 8 x 37 Grain Auger: (1) Tow Hitch, (2) Inlet, (3) Auger Tube, (4) Truss Cables, (5) Gear Box, (6) Elevating Track, (7) Drive Shaft, (8) Upper End Drive, (9) Discharge Spout, (10) Elevating Carriage, (11) Hydraulic Winch, (12) Power Take-off Drive Line, (13) Lower Arms.

### SUMMARY AND CONCLUSIONS

At a 30° elevation angle corresponding to a discharge height of 5.3 m (17.4 ft), and at the manufacturer's recommended flying speed of 540 rpm, capacity of the McIntyre 8 x 37 was 44.6 t/h (1640 bu/h) in wheat, 33.5 t/h (2300 bu/h) in oats, 40.3 t/h (1580 bu/h) in corn and 40.8 t/h (1800 bu/h) in rapeseed. Maximum capacities occurred at flying speeds between 600 and 700 rpm.

Power requirements ranged from 3 to 8 kW (4 to 11 hp) in dry grain. Capacity and power depended on flying speed, elevation angle, grain type and moisture content. A 10 kW (13 hp) power supply should have ample power reserve to operate the McIntyre in most conditions.

Grain damage in dry wheat was less than 0.2% for each pass through the auger.

Although the McIntyre had a high degree of stability, considerable effort was needed to maneuver the McIntyre due to the heavy hitch weight.

All pulleys, gears and rotating drive shafts were well guarded. The inlet guard did not meet current safety recommendations.

No operator manual was provided.

No durability problems occurred during the test.

### RECOMMENDATIONS

It is recommended that the manufacturer consider:

1. Providing a method of limiting the movement of the elevating carriage when it reaches the end of the track.

2. Providing a means of controlling the speed of the hydraulic winch.
3. Providing an inlet safety guard meeting current safety standards.
4. Placing a caution decal on the drive line advising alignment practices and permissible extension of the power take-off drive line.
5. Providing an operator manual.

Chief Engineer -- E.O. Nyborg

Senior Engineer -- J. C. Thauberger

Project Engineer -- Carl W. Bolton

### THE MANUFACTURER STATES THAT

With regard to recommendation number:

1. Later models have this incorporated in the design.
2. This control is optional with the hydraulic winch.
3. This is being investigated and possibly an even safer method is under consideration.
- 4,5. A danger decal is provided and detailed aligning instructions are included in the manual presently being compiled.

**Note:** This report has been prepared using SI units of measurement. A conversion table is given in APPENDIX III.

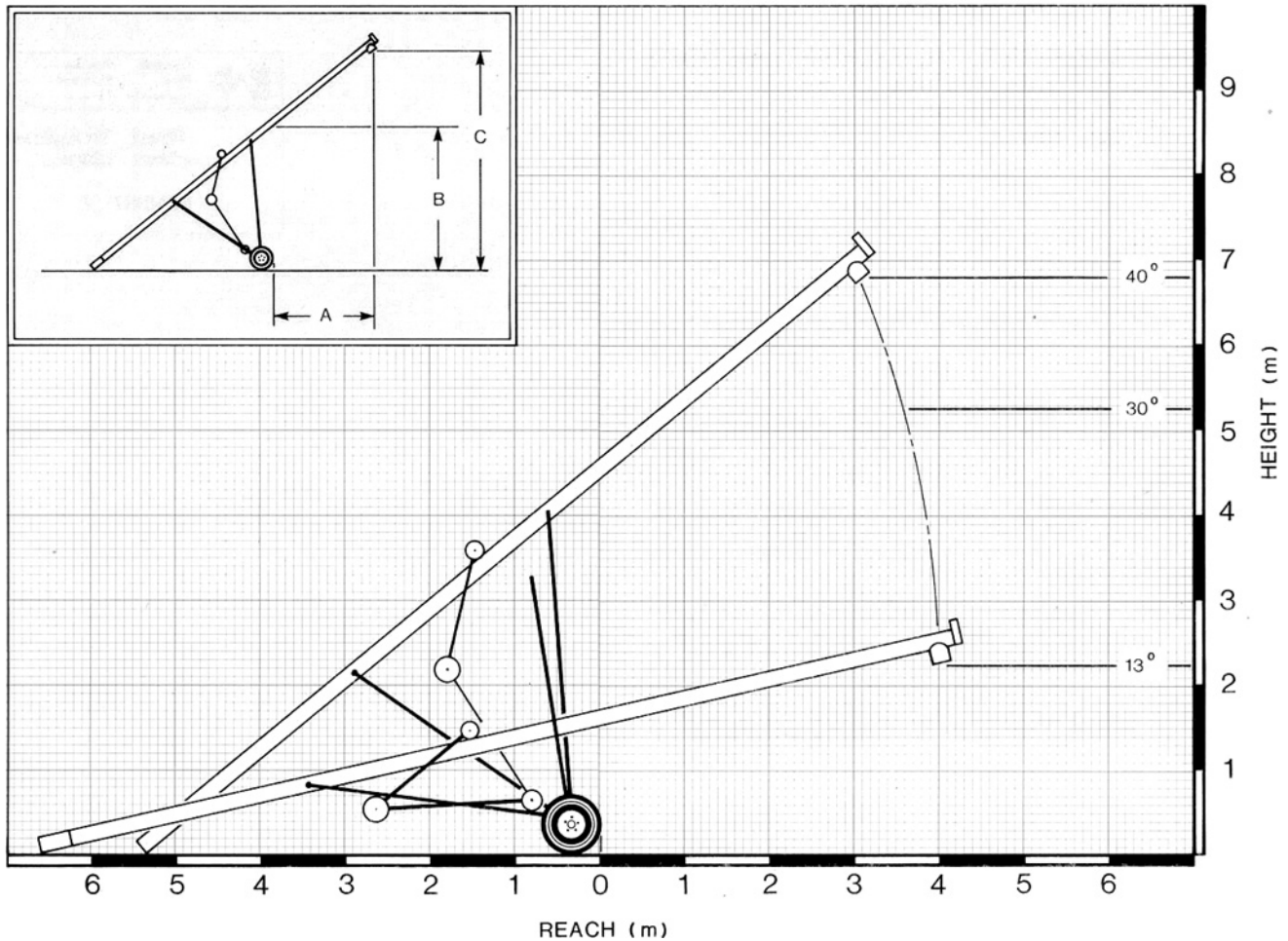

FIGURE 2. Reach and Clearance at Various Heights: (A) Reach, (B) Bin Eave Clearance, (C) Discharge Height.

## GENERAL DESCRIPTION

The McIntyre 8 x 37 grain auger (FIGURE 1) is a 205 mm (8 in) diameter, 11.3 m (37 ft) long portable screw conveyor. The auger tube is mounted on a carriage with tubular track and support members mounted on a single axle with two wheels. Additional tube support is provided by a truss cable mounted on the top of the auger tube. A hydraulic winch is used to adjust the auger angle to vary the discharge height. The cupped flighting assembly is mounted in bushings at both the inlet and discharge ends.

The McIntyre may be powered with a tractor power take-off drive, a gasoline engine or electric motor. Power is transmitted through a series of V-belts, a gearbox and drive shaft to a top end gear drive.

The test machine was equipped with a 540 rpm tractor power take-off drive and an optional hydraulic winch powered by the tractor hydraulic system.

Detailed specifications are given in APPENDIX I.

## SCOPE OF TEST

The McIntyre was operated for about 10 hours while conveying dry wheat, oats, corn and rapeseed. It was also operated in a standard test material (APPENDIX II) for about one hour. As well, it was transported over gravel and paved highways for a distance of 60 km (40 miles). It was evaluated for ease of operation and adjustment, rate of work, power requirements, quality of work, operator safety and suitability of the operator manual.

## RESULTS AND DISCUSSION

### EASE OF OPERATION AND ADJUSTMENT

**Discharge Height:** The discharge height could be conveniently varied from 2.3 to 6.8 m (7.4 to 22.3 ft) with the hydraulic winch. Corresponding elevation angles ranged from 13° to 40°. The regular lift mechanism raised the auger to 30°. Removable tubular extension stubs, which were stored on the undercarriage, were

used to increase the angle of elevation to 40°. The hydraulic winch motor needed an oil pressure of 4000 to 6500 kPa (800 to 1300 psi) to raise the empty auger.

Raising and lowering speed depended on the oil flow from the tractor hydraulic system. When using tractors with high flow rates extreme care had to be used. Since no flow control was provided the auger was raised very quickly. It is recommended that the manufacturer provide a flow control for the hydraulic winch motor.

As well, the operator had to take care to ensure that the auger was not raised beyond the end of the elevating tracks. It is recommended that the manufacturer provide some method of limiting the maximum movement of the elevating carriage.

A manual brake locked the winch drum at desired settings. The brake was sometimes difficult to disengage.

**Auger Reach:** The bin eave clearance and horizontal reach of the McIntyre 8 x 37 are shown in FIGURE 2. Bin eave clearance, measured from the ground to the foremost part of the undercarriage, varied from 2.3 m (7.6 ft) at 13° to 4.1 m (13.4 ft) at 40° elevation. The reach, measured from the foremost part of the undercarriage to the centre of the discharge, varied from 4.0 m (13.2 ft) at 13° to 3.0 m (9.9 ft) at 40° elevation.

Hitch weight varied from 48 kg (105 lb) at minimum elevation to 45 kg (100 lb) at maximum elevation.

**Adjustments:** Sag in the auger tube could be eliminated by tightening a threaded eyebolt controlling the truss cable tension.

The drive contained two sets of belts which permitted the power take-off drive line to remain horizontal at all elevations. Primary drive belt tension was adjusted with a threaded bolt. Secondary drive belt tension was controlled with an adjustable over-centre hand lever.

**Transporting:** The McIntyre transported well and was stable at speeds up to 100 km/h (60 mph) on paved highways and up to 50 km/h (30 mph) on gravel roads. The hitch on the inlet end provided a reliable coupling to the tow vehicle. The operator should

use a suitable hitch pin and safety chain to prevent accidental unhitching when transporting on public roads.

Clearance under power lines was adequate. The transport height was 3.3 m (10.9 ft) when fully lowered.

#### RATE OF WORK

**Capacity:** FIGURE 3 shows the capacity of the McIntyre 8 x 37 in dry wheat, oats, corn and rapeseed at a 30° elevation angle. The maximum capacities were 47.2, 34.4, 43.0 and 43.7 t/h (1730, 2370, 1690, and 1920 bu/h) in wheat, oats, corn and rapeseed, respectively. Lower capacities can be expected for tough or damp grains. Maximum capacities occurred at flighting speeds ranging from 600 to 700 rpm.

**Specific Capacity:** The specific capacity, per metre of vertical lift, is a method of determining the efficiency of a grain auger. A low specific capacity indicates inefficient power use, while a high specific capacity indicates efficient operation. Specific capacities vary, depending on grain type. In general, when the flighting speed is increased, the capacity increases at a lower rate than the increase in power requirements, leading to an overall decrease in specific capacity.

As is shown in FIGURE 3 the specific capacity<sup>1</sup> ranged from 1.03 to 1.84 t/kW-h per metre of vertical lift when operating at a 30° elevation angle in dry wheat, oats, corn and rapeseed.

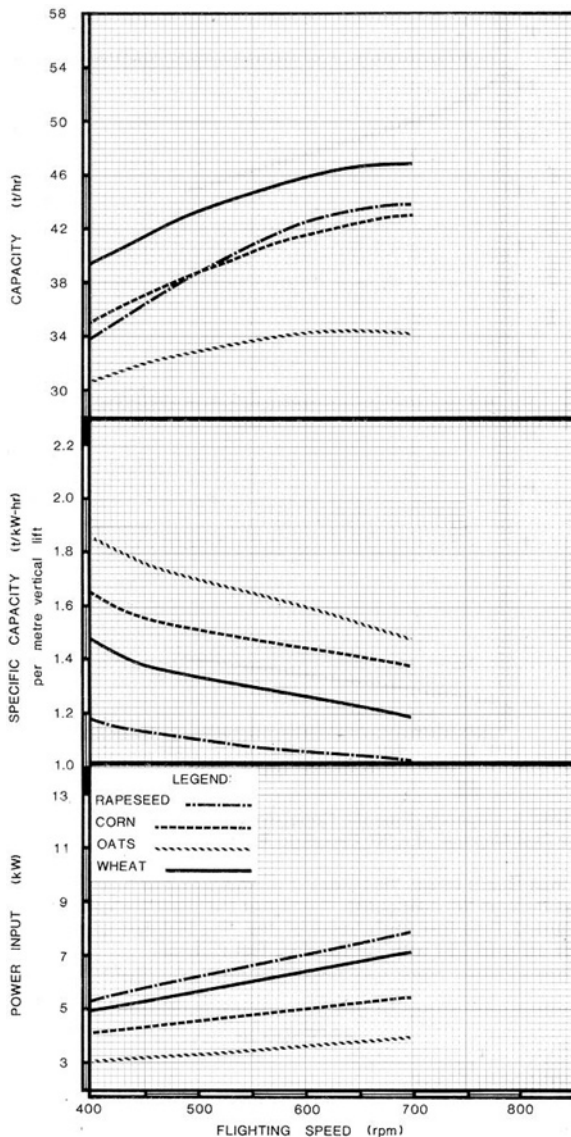

**FIGURE 3.** Capacity, Specific Capacity and Input Power for Various Flighting Speeds at a 30° Elevation Angle.

<sup>1</sup>Since the specific capacity is greatly dependent upon grain properties, such as variety and moisture content, FIGURE 3 should not be used for comparing efficiencies of different augers. The data presented in FIGURE 5, APPENDIX II, using a standard medium, may be used for comparisons of different augers. Page 4

**Critical Speeds:** At certain critical flighting speeds, auger vibration becomes excessive. This phenomenon, known as resonance, is common to all grain augers and varies with grain type and operating conditions. Care should be taken not to operate at or near critical speeds.

#### POWER REQUIREMENTS

FIGURE 3 gives the power requirements for the McIntyre 8 x 37 in dry wheat, oats, corn and rapeseed at a 30° elevation angle. Power requirements ranged from 3 to 8 kW (4 to 11 hp). More power would be needed in high moisture grain. In general, a 10 kW (13 hp) power supply should have ample power reserve to operate the McIntyre in most conditions.

#### QUALITY OF WORK

**Grain Damage:** Damage in dry wheat was less than 0.2% for each pass through the auger. This was insignificant as long as the same grain was not augered many times. Crackage would be lower at higher moisture contents.

#### OPERATOR SAFETY

The power take-off drive line and rotating shaft couplers were well shielded. The inlet safety guard (FIGURE 4) did not meet the current standards for grain augers.<sup>2</sup> The openings of the guard were too large and the guard did not extend sufficiently beyond the exposed flighting. It is recommended that the inlet guard be modified to comply with current safety standards.

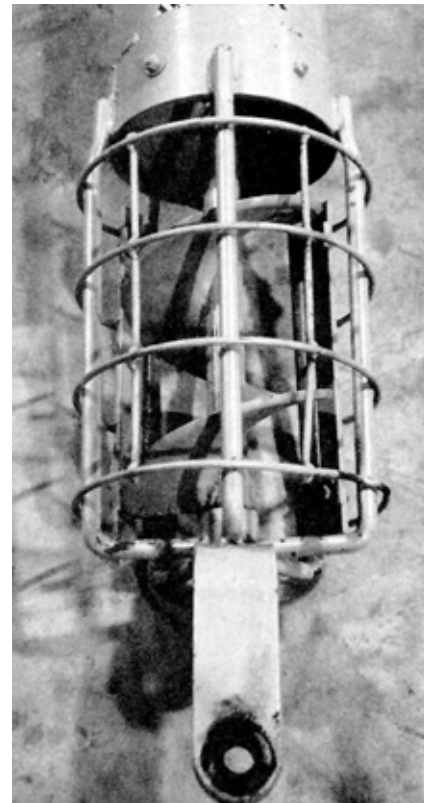

**FIGURE 4.** Inlet Safety Guard

No warning signs were provided to alert the operator to the possible hazard of raising the elevating carriage beyond the end of the tracks.

The power take-off drive line could separate if the tractor was placed too far away from the auger. It is recommended that a caution decal be placed on the drive line advising on alignment practices and permissible drive line extension.

<sup>2</sup>American Society of Agricultural Engineers Tentative Standard: ASAE S 361.1T, "Safety for Agricultural Auger Conveying Equipment". December 1978.

**OPERATOR MANUAL**

No operator manual was provided. It is recommended that the manufacturer supply a manual outlining operating, servicing and safety procedures.

**DURABILITY RESULTS**

The McIntyre was operated for about 10 hours. The intent of the test was evaluation of functional performance. An extended durability evaluation was not conducted. No mechanical problems occurred during the test.

**APPENDIX I**

**SPECIFICATIONS**

<b>Serial Number:</b>	3797-1979-566	
<b>Make:</b>	McIntyre	
<b>Model:</b>	8 x 37	
<b>Overall Dimensions:</b>		
-- length	11,140 mm	
-- width	2740 mm	
<b>Auger Tube:</b>		
-- inside diameter	205 mm	
-- inlet length	370 mm	
-- material thickness	2.3 mm	
-- outlet size	elliptical 265 mm x 205 mm	
<b>Flighting:</b>		
-- diameter	182 mm	
-- pitch -- exposed	185 mm cupped	
-- covered	185 mm	
-- material thickness	4.3 mm, 2.2 mm, 1.7 mm	
-- exposed length	315 mm	
-- core diameter	33.5 mm	
<b>Elevating Height:</b>		
-- maximum (40°)	6795 mm	
-- minimum (13°)	2255 mm	
<b>Lubrication Points:</b>		
-- pressure grease fittings	9	
-- sealed bearings	6	
-- bushings	7	
-- wheel bearings (packed)	2	
<b>Drive:</b>		
-- 540 rpm tractor power take-off		
-- power take-off flighting speed ratio	1:1.03	
-- auxiliary drive		
-- V-belt	4 (B-144)	
-- roller chain	1 (50-50P)	
-- gear boxes	2	
<b>Winch:</b>		
-- make and model	McIntyre Hydraulic Winch	
<b>Bin Eave Clearance @ maximum elevation:</b>	4100 mm	
<b>Reach at maximum elevation:</b>	3000 mm	
<b>Tires:</b>		
-- size	4 ply H78-15	
-- tread width	2525 mm	
<b>Inlet Safety Shield:</b>		
-- type of grill	rod	
-- material dimensions	6.9 mm dia	
-- grill openings	89 mm x 133 mm	
-- maximum open area	119 cm <sup>2</sup>	
-- maximum open dimension	1330 mm	
-- overall size	300 mm L x 265 mm dia	
<b>Weight:</b>		
	<u>Maximum Elevation</u>	<u>Minimum Elevation</u>
-- right wheel	285 kg	285 kg
-- left wheel	260 kg	260 kg
-- hitch point	50 kg	50 kg
Total	595 kg	595 kg
<b>Optional Equipment:</b>		
-- inlet hopper, hydraulic winch and control		

**APPENDIX II**

**PERFORMANCE CURVES WITH STANDARD TEST MATERIAL<sup>3</sup>**

(a) Capacity and Power Requirements. FIGURE 5 gives the capacity, specific capacity and power requirements for the McIntyre 8 x 37 in a standard test material. These data may be used for comparisons of different grain augers.

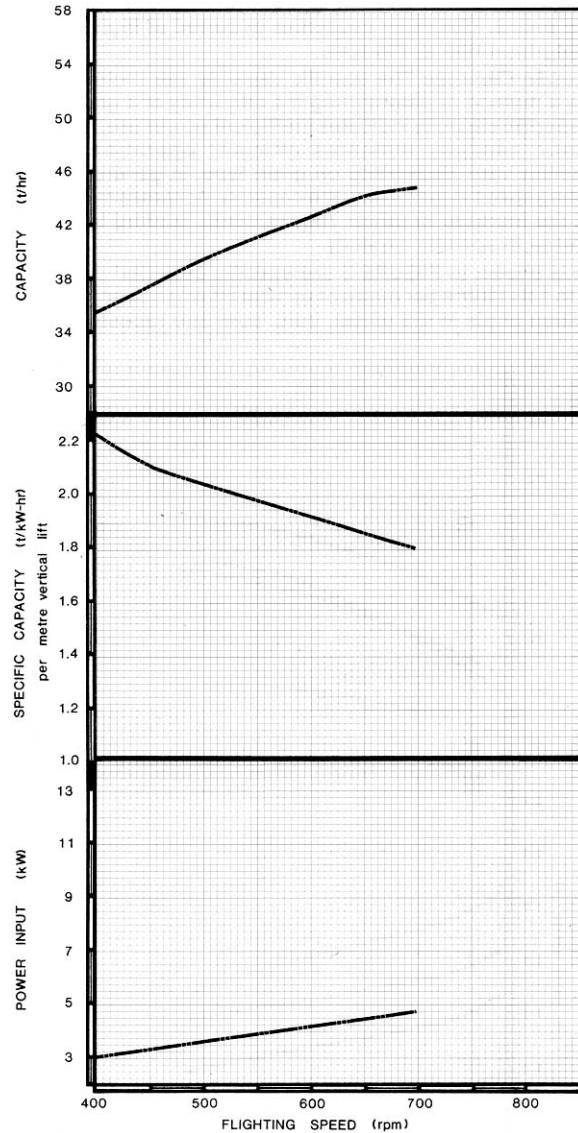

**FIGURE 5.** Capacity, Specific Capacity and Power Input with a Standard Test Material at a 30° Elevation Angle.

(b) Inlet Guard Index. This index is an indication of how freely grain flows through the inlet guard. The higher the index the less restrictive the guard. Free flow has a value of one. The McIntyre guard had an index value of 0.64 with the standard test material.

**APPENDIX III**

**CONVERSION TABLE**

1 tonne (t)	=	2200 pounds mass (lb)
1 metre (m)	=	3.3 feet (ft)
1 kilowatt (kW)	=	1.3 horsepower (hp)
1 kilogram (kg)	=	2.2 pounds mass (lb)
1 newton (N)	=	0.2 pounds force (lb)

<sup>3</sup>The standard test material is a high density granular polyethylene. The material is consistent and not subject to damage or changes in physical properties as are grains.



**ALBERTA  
FARM  
MACHINERY  
RESEARCH  
CENTRE**

3000 College Drive South  
Lethbridge, Alberta, Canada T1K 1L6  
Telephone: (403) 329-1212  
FAX: (403) 329-5562  
<http://www.agric.gov.ab.ca/navigation/engineering/afmrc/index.html>

**Prairie Agricultural Machinery Institute**

Head Office: P.O. Box 1900, Humboldt, Saskatchewan, Canada S0K 2A0  
Telephone: (306) 682-2555

Test Stations:  
P.O. Box 1060  
Portage la Prairie, Manitoba, Canada R1N 3C5  
Telephone: (204) 239-5445  
Fax: (204) 239-7124

P.O. Box 1150  
Humboldt, Saskatchewan, Canada S0K 2A0  
Telephone: (306) 682-5033  
Fax: (306) 682-5080