

Evaluation Report 690



Brandt 852 Super-Charged Grain Auger

A Co-operative Program Between



ALBERTA
FARM
MACHINERY
RESEARCH
CENTRE



PRAIRIE AGRICULTURAL MACHINERY INSTITUTE

BRANDT 852 SUPER-CHARGED GRAIN AUGER

MANUFACTURER AND DISTRIBUTOR:

Brandt Industries Ltd.
705 Toronto Street
Regina, Saskatchewan
S4P 3A2
Tel: (306) 525-1314

Retail Price: \$3,225.00; basic auger with no options (July 1991, f.o.b. Portage la Prairie, MB).

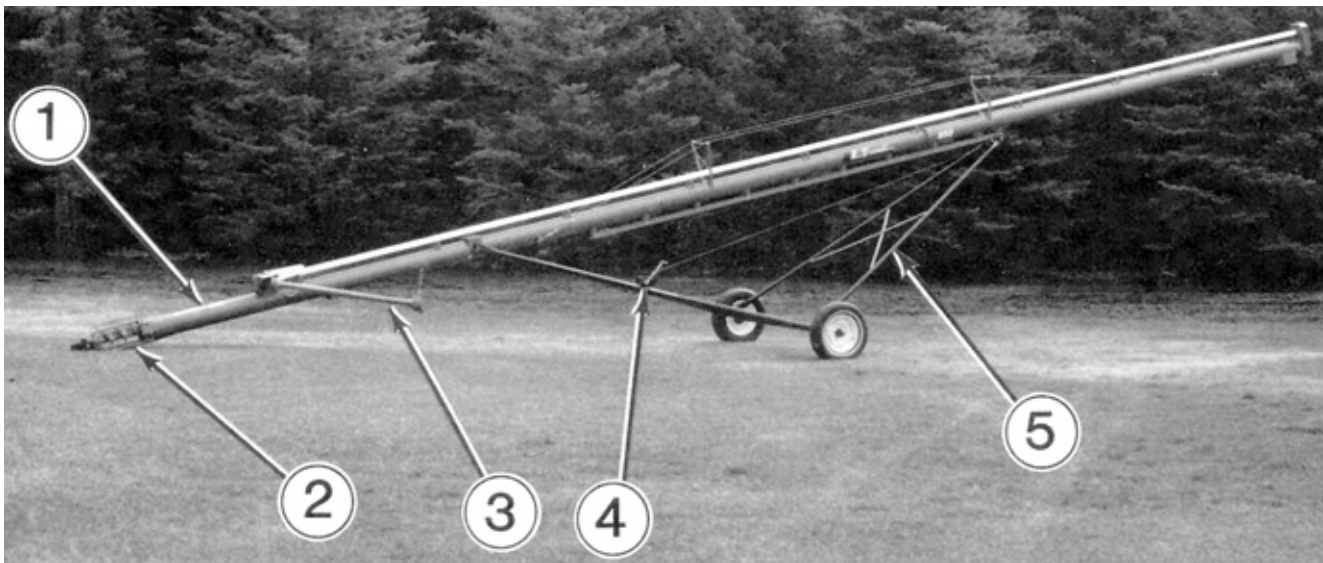

FIGURE 1. Brandt 852 Super-Charged: (1) Main Auger Tube, (2) Super-Charger Inlet, (3) PTO Drive, (4) Lift Winch, (5) Undercarriage.

SUMMARY

Rate of Work: At the 30° elevation angle, corresponding to a discharge height of 26.5 ft (8.1 m) maximum capacities were 3590, 3580, 3775, 3040 bu/hr (103, 68, 99, 66 t/h) in wheat, oats, canola, and standard material respectively. Maximum capacities were usually obtained at flighting speeds between 440 and 600 rpm.

Quality of Work: Quality of work was good. In dry wheat, damage was less than 0.2% for each pass through the auger.

Ease of Operation and Adjustment: The discharge height could be varied from 12.3 to 33.3 ft (3.8 to 10.1 m). Bin eave clearance varied from 8.1 to 17.3 ft (2.5 to 5.3 m) and reach varied from 15.3 to 24.0 (4.7 to 7.3 m) at elevation angles of 13° to 41°, respectively.

Ease of operation was good. The Brandt 852 was easy to manoeuvre and position due to the relatively light hitch weight of 57 lb (26 kg). Adjustments for discharge height were accomplished by rotating the cable winch handle.

Ease of hitching was very good. The removable tow hitch was easily installed for towing and easily removed for operation of the auger.

Ease of transporting was very good. It was stable at speeds up to 20 mph (35 km/h) on paved highways.

Ease of lubrication was very good. Only the power shaft had grease pressure nipples.

Power Requirements: Power requirements for the Brandt 852 auger ranged from 5.5 to 18.8 hp (4.1 to 14.1 kW) in dry grain.

Operator Safety: Operator safety was good if normal precautions for safety were observed. The auger complied with all current standards for safety.

Operator's Manual: The operator's manual was very good. It was well written, organized and illustrated.

Mechanical History: One minor problem occurred during the testing period.

RECOMMENDATIONS

It is recommended that the manufacturer consider:

1. A modification to the slide roller assembly that pushes up the auger tube that would prevent the slide roller assembly from binding.
2. A modification that would prevent a top heavy imbalance when grain is concentrated in the top portion of the auger tube during clean out.

Station Manager: B. H. Allen

Project Manager: R. K. Harris

THE MANUFACTURER STATES THAT

With regard to the recommendation (1-2):

1. The slide roller was redesigned in May, 1991 to combine the roller with the double pull. This removes the twisting force experienced during the testing.
2. The auger axle frame was redesigned in May, 1992. The new balance point increases the hitch weight to approximately 80 lbs (depending on the drive option of the auger),

GENERAL DESCRIPTION

The Brandt 852 Super-Charged Grain Auger is an 8 in (203 mm) diameter 52 ft (15.8 m) long portable screw conveyor. The auger tube is mounted on a tubular steel undercarriage and is raised or lowered mechanically with a hand winch and cable. The inlet end of the auger is supplied with a removable hitch that is used for towing, while the undercarriage is supported by two wheels with rubber tires.

Detailed specifications are presented in APPENDIX I.

SCOPE OF TEST

The machine evaluated by PAMI was configured as described in the General Description, FIGURE 1 and the specifications section of this report. The manufacturer may have built different configurations of this machine before or after PAMI tests. Therefore, when using this report, check that the machine under consideration is the same as the one reported here. If differences exist, assistance can be obtained from PAMI or the manufacturer to determine changes in performance.

The Brandt 852 was operated for about 30 hours during the duration of the test. Prior to capacity and power tests, the auger was used for about 15 hours moving wheat, barley and canola. During the capacity and power tests, the auger was operated for an additional 15 hours.

The auger was evaluated for: capacity, specific capacity, power requirements, operator safety, and suitability of the operator's manual. Mechanical history was also recorded.

RESULTS AND DISCUSSION

RATE OF WORK

Capacity: FIGURE 2 shows the capacities of the Brandt 852 in various grains at 30° elevation angle. Maximum capacities at this angle were 3590, 3580, 3775, 3040 bu/h (103, 68, 99, 66 t/h) in wheat, oats, canola, and standard material respectively. As fighting speeds are increased, the capacity of screw conveyors increases to a peak, then levels off or decreases. Maximum or peak capacities for the Brandt 852 occurred at fighting speeds between 440 and 600 rpm.

The effect of elevation angle on capacity is illustrated in TABLE 1. Peak capacities in wheat dropped 19.6% from 3760 bu/h (108 t/h) at 20° elevation to 3020 bu/h (87 t/h) at maximum of 41° elevation.

Specific Capacity: Specific capacity is the amount of grain moved per unit of power in a specific time. A high specific capacity indicates efficient use of power. In general, specific capacity decreases (less grain is moved per horsepower hour) with increasing fighting speeds and elevation angle. Specific capacity at 30 ranged from 5.2 to 8.6 ton/hp-h (6.3 to 10.5 t/kW-h) in dry wheat, oats, canola and standard material.

Critical Speeds: At certain critical fighting speeds auger vibration may become excessive. This phenomenon, known as resonance is common to all augers. It would appear that this critical speed is outside the operating speed range of the Brandt 852 as it did not appear within the speeds the auger was operated at during the evaluation.

QUALITY OF WORK

Grain Damage: Quality of work was very good. Damage in dry wheat (13% moisture content) was 0.2% for each pass through the auger. This is considered to be acceptable in comparison to other makes of augers. Grain damage would not be significantly reduced when moving crops of higher moisture content.

EASE OF OPERATION AND ADJUSTMENT

Discharge Height: Auger discharge height adjustment was good.

The discharge height (FIGURE 3) could be varied from 12.3 to 33.3 ft (3.7 to 10.1 m) with the mechanical cable winch mechanism. Corre-

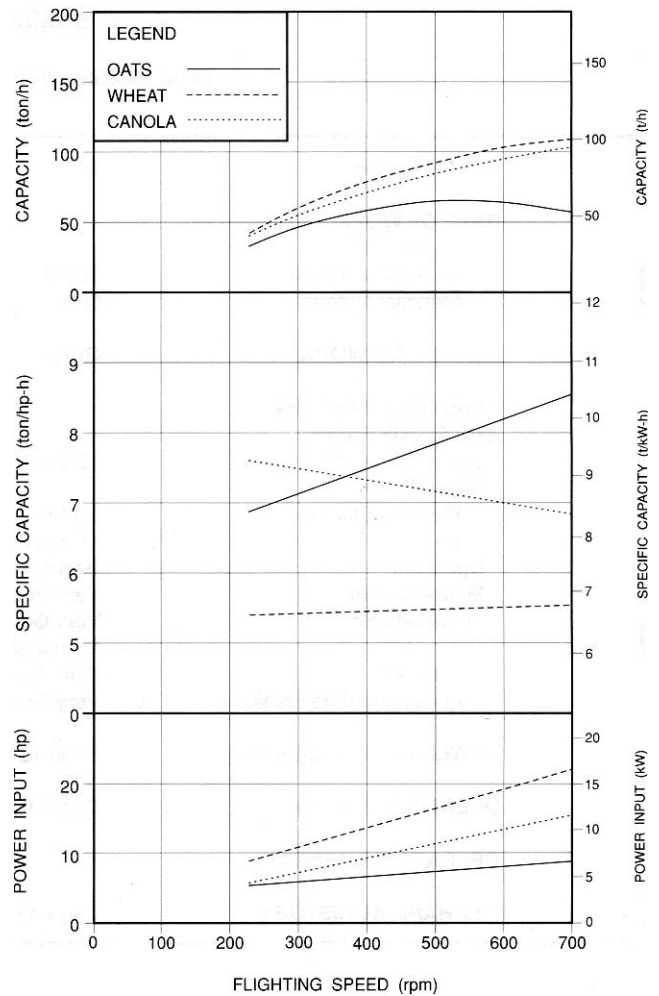

FIGURE 2. Capacity, Specific Capacity and Power Requirements for various fighting speeds at 30°.

TABLE 1. Peak capacity, Specific Capacity and Power Requirements vs Elevation Angle (dry wheat)

| ELEVATION ANGLE degrees | DISCHARGE HEIGHT ft (m) | PEAK CAPACITY bu/h (t/h) | SPECIFIC CAPACITY ton (t) hp-h (KW-h) | POWER INPUT hp (kW) |
|-------------------------|-------------------------|--------------------------|---------------------------------------|---------------------|
| 20 | 18.0 (5.5) | 3760 (108) | 6.2 (7.6) | 17.4 (13) |
| 30 | 26.5 (8.1) | 3580 (102) | 5.5 (6.7) | 18.8 (14) |
| 41 | 33.3 (10.2) | 3020 (87) | 5.0 (6.1) | 17.5 (13) |

sponding elevation angles varied from 13° to 41°.

The auger discharge height was adjusted from the ground by rotating the cranks on the cable winch until the desired discharge height was obtained.

Auger Reach: The bin eave clearance and horizontal reach (FIGURE 3) of the Brandt 852 are shown in TABLE 2. Bin eave clearance, measured from the ground to the auger tube at the foremost part of the undercarriage, varied from 8.1 to 17.3 ft (2.4 to 5.3 m) at 13° and 41° respectively. The reach, measured from the foremost part of the undercarriage to the centre of the discharge, varied from 15.3 to 24.0 ft (4.7 to 7.3 m) at 13° and 41° respectively.

Operation: Ease of operation was good. The Brandt 852 was easily positioned at the unloading/loading site. The operator's manual clearly states that the auger should be positioned while attached to a towing vehicle, however some positioning had to be done by hand. The auger was prepared for operation by raising the auger tube to the desired discharge height, and removing the hitch assembly from its attachment bracket. Fitting a suitable intake hopper and connecting the power shaft to the tractors PTO shaft completed set up.

TABLE 2. Reach, Clearance and Discharge Height at Various Elevations.

| ELEVATION ANGLE degrees | A HORIZONTAL REACH | | B BIN EAVE CLEARANCE | | C DISCHARGE HEIGHT | |
|-------------------------|--------------------|-------|----------------------|-------|--------------------|--------|
| | ft | (m) | ft | (m) | ft | (m) |
| 13° | 15.3 | (4.7) | 8.1 | (2.4) | 12.3 | (3.7) |
| 20° | 17.5 | (5.4) | 11.5 | (3.5) | 18.0 | (5.5) |
| 30° | 21.7 | (6.6) | 13.5 | (4.1) | 26.5 | (8.1) |
| 41° | 24.0 | (7.3) | 17.3 | (5.3) | 33.3 | (10.1) |

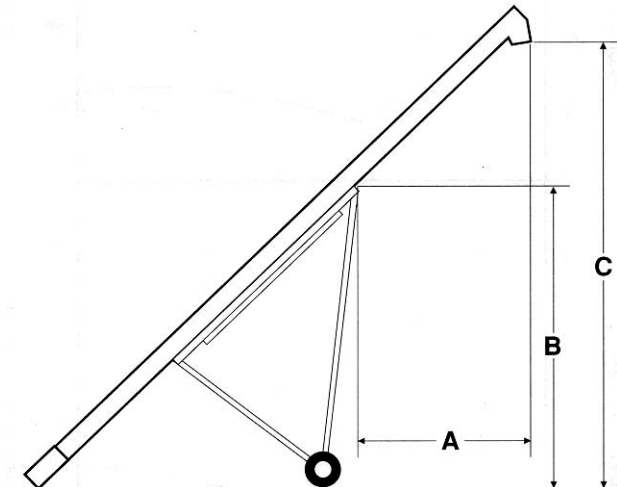

FIGURE 3. Dimensions: (a) Horizontal Reach, (b) Bin Eave Clearance, (c) Discharge Height.

Adjustments: Ease of adjusting the discharge height was fair. Turning the crank for the cable winch was tiring. The crank required 146 complete turns to raise the auger tube from minimum angle of elevation to maximum, while requiring a force of 51 lbs (227 N). When lowering the auger tube, a faulty roller assembly caused the auger tube support frame to bind (FIGURE 4). The support frame had to be winched with a come along toward the discharge end of the auger to free the roller assembly. It is recommended that the manufacturer consider a modification to the slide roller assembly that pushes up the auger tube that would prevent the slide roller assembly from binding.

Manoeuvrability: Manoeuvrability was very good. The Brandt 852 was easily moved into operating position when attached to a towing vehicle. The operator's manual clearly states that the auger should not be manoeuvred by hand, however, some final positioning was necessary by hand.

Transportability: Transporting the Brandt 852 was very good. The auger was stable at speeds up to 20 mph (35 km/h) on paved highways and up to 15 mph (25 km/h) on gravel roads. The test auger was equipped with used automobile tires.

The Brandt 852 was prepared for transporting by lowering the auger tube angle to its lowest position of 13° and attaching the hitch assembly in its bracket (FIGURE 4). The power shaft was secured in transport position with a chain that held the shaft more or less parallel to the auger tube. Clearance under power lines was ample when fully lowered. The transport height was 14.6 ft (4.3 m).

Lubrication and Maintenance: Lubrication and maintenance of the Brandt 852 was very good. Lubricating the auger consisted of ensuring an adequate supply of EP 90 gear oil in the gear box and greasing wheel bearings semi-annually. In addition, the universal joints in the power shaft required grease every 10 hours.

Maintenance consisted of ensuring proper chain tension and sprocket alignment.

POWER REQUIREMENTS

Power requirements for the Brandt in dry wheat (FIGURE 2) ranged from 7.4 to 18.8 hp (5.5 to 14.1 kW). The Brandt 852 required a tractor with a PTO shaft capable of 540 rpm and at least 30 hp (22 kW).

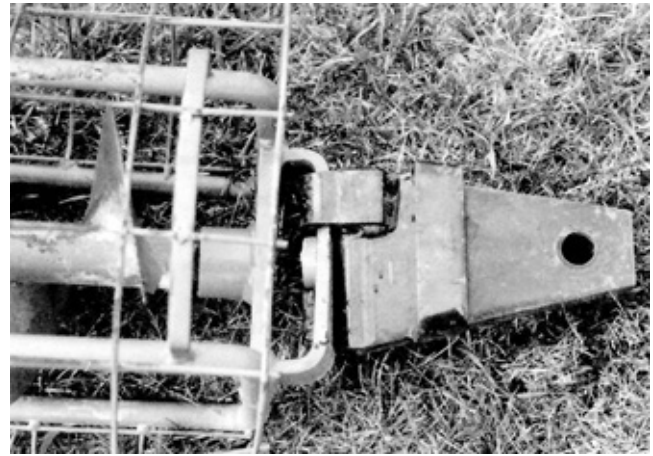

FIGURE 4. Hitch Assembly.

If augers are used to move damp grain the power source should be sized accordingly. The power requirement for augers without side delivery will increase by approximately 5%, 33% and 50% when moving damp canola, corn and wheat respectively.

OPERATOR SAFETY

Operator safety was good if appropriate safety precautions were observed. When crop becomes concentrated in the discharge end of the auger during cleanout, an imbalance occurs resulting in the inlet end of the auger rising and the discharge falling. It is recommended that the manufacturer consider a design modification that would prevent the auger from becoming unbalanced when crop is concentrated at the discharge end.

The Brandt 852 complied with all current ASAE standards for safety for agricultural screw conveyors. The auger inlet was protected and enclosed in a mesh grate that completely surrounded the exposed fighting. In addition rotating shafts and universal joints were adequately guarded.

OPERATOR'S MANUAL

The operator's manual was very good. It was well written, organized and illustrated. It contained useful information on safety, assembly, operation, specifications, maintenance, gear boxes and parts list.

MECHANICAL HISTORY

During the 30 hours of operation only one minor mechanical problem occurred. The auger was supplied with a faulty slide roller assembly (FIGURE 5). The faulty assembly would bind and would not allow the auger tube to be lowered from its maximum height position. The roller was replaced and the problem did not recur.

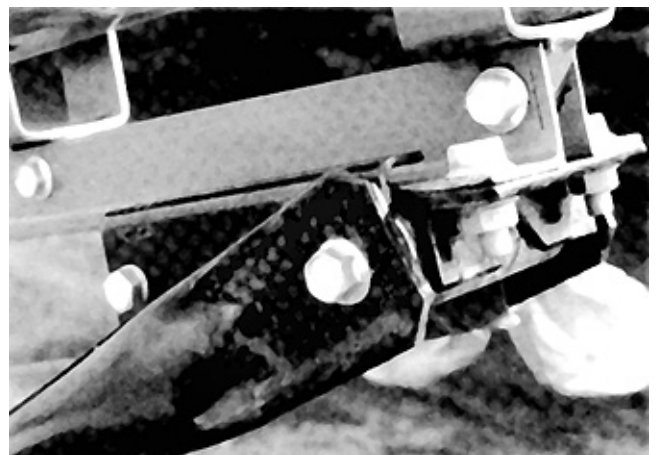

FIGURE 5. Slide Roller Assembly.

APPENDIX I

SPECIFICATIONS

| | | |
|-------------------------------------|---|-------------------|
| MAKE: | Brandt | |
| MODEL: | 852 Super-Charger | |
| SERIAL NUMBER: | 22391 A | |
| OVERALL DIMENSIONS: | | |
| - Transport Length | 52.0 ft (15.8 m) | |
| - Field Width | 7.5 ft (2.3 m) | |
| - Transport Width | 7.5 ft (2.3 m) | |
| - Transport Height | 14.0 ft (4.3 m) | |
| DRIVE: | | |
| - 540 rpm Tractor Power Take Off | | |
| - 1:1 Direction Changing Gearbox | | |
| - Power Take-Off to Flighting | | |
| Speed Ratio | 1,12:1 | |
| LUBRICATION: | | |
| - Pressure Grease Fittings | on power shaft only | |
| - Packed Wheel Bearings | 2 sets (pack semi annually) | |
| - Gearbox | EP 90 Gear Oil (as required) | |
| - Universal Joints | Every 10 Hours | |
| AUGER TUBE: | | |
| - Length | 52.0 ft (15.8 m) | |
| | INLET | DISCHARGE |
| - Inside Diameter | 9 in (229 mm) | 8 in (203 mm) |
| - Material Thickness | 0.070 in (2 mm) | |
| FLIGHTING: | INLET | DISCHARGE |
| | (Super-Charger) | |
| - Diameter | 8.5 in (215 mm) | 6.8 in (175 mm) |
| - Pitch | 5.0 in (127 mm) | 5.0 in (127 mm) |
| - Exposed Length | 16.7 in (425 mm) | |
| - Thickness | | |
| - Inner | 0.060 in (1.5 mm) | 0.060 in (1.5 mm) |
| - Outer | 0.190 in (5 mm) | 0.190 in (5 mm) |
| INNER SAFETY GUARD: | | |
| - Material Dimensions | 0.157 in (4 mm) | |
| - Overall Size | 20 x 14.5 in (517 x 369 mm) | |
| - Grill Openings | 2.7 x 2.7 in (70 x 70 mm) | |
| - Maximum Open Area | 7.8 in ² (5040 mm ²) | |
| - Maximum Guarded Diameter | 360° | |
| LIFT MECHANISM: | | |
| - Type | Hand Winch | |
| - Make | Shelby Industries | |
| - Model | 5352 | |
| - Number of Turns to Max. Elevation | 146 | |
| - Maximum Handle Force | 51 lbs (226.8 N) | |
| - Cable (Wire Rope) Diameter | 0.264 in (6.5 mm) | |
| WEIGHT: | | |
| - Minimum Elevation | | |
| - Right Wheel | 578 lb | (262 kg) |
| - Left Wheel | 586 lb | (266 kg) |
| - Hitch | 58 lb | (26 kg) |
| TOTAL | 1222 lb | (554 kg) |
| - Transport Hitch Weight | | |
| 16 in (400 mm) off ground | 58 lb | (26 kg) |
| TIRES: | | |
| - Size | P215-70R | |
| - Number | 2 | |
| - Type Used | Automobile | |

APPENDIX II

PERFORMANCE WITH STANDARD MATERIAL

The standard test material is a high density granular polyethylene. The material is consistent and not subject to damage or changes in physical properties as are grains.

FIGURE 6 gives the capacity, specific capacity, and power requirements for the Brandt 852 Super-Charger in a standard test material. This data may be used for comparison of different grain augers.

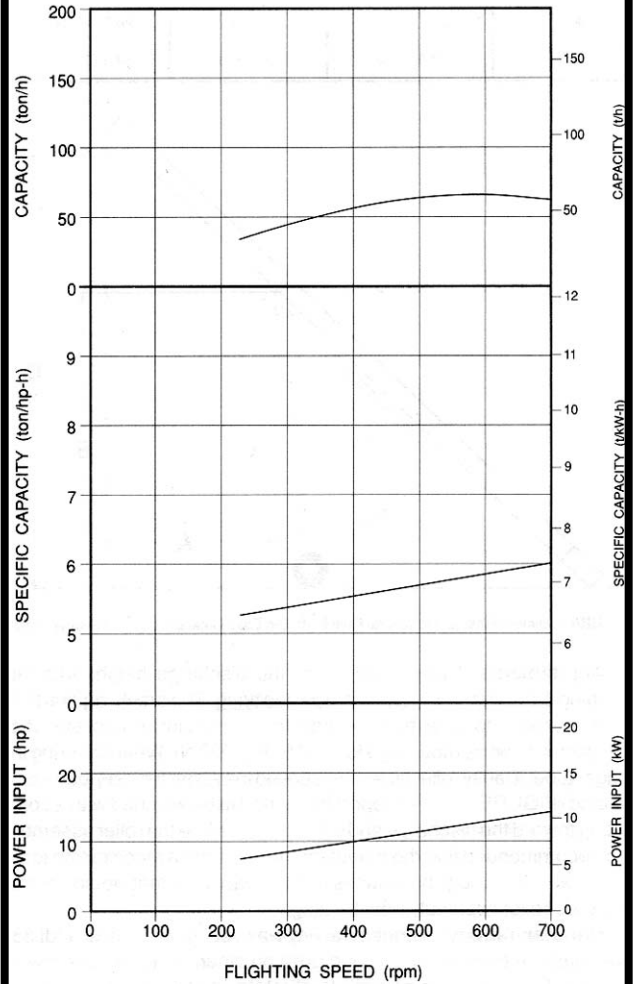

FIGURE 6. Capacity, Specific Capacity, and Power Requirements with Standard Test Material at 30° of elevation angle.

APPENDIX III

MACHINE RATINGS

The following rating scale is used in PAMI Evaluation Reports:

| | |
|-----------|----------------|
| Excellent | Fair |
| Very Good | Poor |
| Good | Unsatisfactory |

SUMMARY CHART

BRANDT 852 SUPER-CHARGER GRAIN AUGER

| | |
|---|--|
| RETAIL PRICE | \$3225.00 (July 1991, f.o.b. Portage la Prairie, MB) |
| RATE OF WORK | |
| Capacity at 30° | |
| - Dry Wheat (13% MC) | 3590 bu/h (103 t/h) |
| - Standard Material | 3040 bu/h (66 t/h) |
| QUALITY OF WORK | Good ; less than 0.2% damage for each pass |
| EASE OF OPERATION AND ADJUSTMENT | |
| Discharge Height | 12.3 to 33.3 ft (3.8 to 10.1 m) |
| Auger Reach | |
| - Bin Eave Clearance | 8.1 to 17.3 ft (2.5 to 5.3 m) |
| - Reach | 15.3 to 24.0 ft (4.7 to 7.3 m) |
| Operation | Good ; easy to manoeuvre |
| Manoeuvrability | Very good ; was easy to position |
| Transportability | Very Good ; stable at speeds of 20 mph (35 km/h) on paved highways and 15 mph (25 km/h) on gravel roads |
| Adjustments | Fair ; Turning winch was tiring |
| Lubrication and Maintenance | Very Good |
| POWER REQUIREMENTS | 5.5 to 18.8 hp (4.1 to 14.1 kW) |
| OPERATOR SAFETY | Good ; If appropriate precautions were observed |
| OPERATOR'S MANUAL | Very Good ; Well written, organized and illustrated |
| MECHANICAL HISTORY | Only one minor problem |



**ALBERTA
FARM
MACHINERY
RESEARCH
CENTRE**

3000 College Drive South
Lethbridge, Alberta, Canada T1K 1L6
Telephone: (403) 329-1212
FAX: (403) 329-5562
<http://www.agric.gov.ab.ca/navigation/engineering/afmrc/index.html>

Prairie Agricultural Machinery Institute

Head Office: P.O. Box 1900, Humboldt, Saskatchewan, Canada S0K 2A0
Telephone: (306) 682-2555

Test Stations:
P.O. Box 1060
Portage la Prairie, Manitoba, Canada R1N 3C5
Telephone: (204) 239-5445
Fax: (204) 239-7124

P.O. Box 1150
Humboldt, Saskatchewan, Canada S0K 2A0
Telephone: (306) 682-5033
Fax: (306) 682-5080