

RESOLUTION A.601(15)

*Adopted on 19 November 1987
Agenda item 12*

PROVISION AND DISPLAY OF MANOEUVRING INFORMATION ON BOARD SHIPS

THE ASSEMBLY,

RECALLING Article 15(j) of the Convention on the International Maritime Organization concerning the functions of the Assembly in relation to regulations and guidelines concerning maritime safety,

RECALLING ALSO that it adopted by resolution A.209(VII) the Recommendation on Information to be Included in the Manoeuvring Booklets in order to ensure uniformity of such information on board ship,

NOTING the importance attached to further enhancement of the safety of navigation,

RECOGNIZING the need to achieve a uniform format and content of the pilot card and the wheelhouse poster, and to establish a framework for the manoeuvring booklet which provides navigators with more detailed information on the manoeuvring characteristics of the ship,

HAVING CONSIDERED the recommendation made by the Maritime Safety Committee at its fifty-third session:

1. ADOPTS the Recommendation on the Provision and the Display of Manoeuvring Information on Board Ships, as set out in the Annex to the present resolution, which supersedes the Recommendation adopted by resolution A.209(VII);
2. INVITES all Governments concerned to take steps to give effect to the Recommendation as soon as possible;
3. REQUESTS the Maritime Safety Committee to keep the Recommendation under review for the purpose of improvement based on new developments in techniques and in the light of experience gained in its application.

ANNEX

**RECOMMENDATION ON THE PROVISION AND THE DISPLAY
OF MANOEUVRING INFORMATION ON BOARD SHIPS**

1 INTRODUCTION

1.1 In pursuance of the Recommendation on Data Concerning Manoeuvring Capabilities and Stopping Distances of Ships, adopted by resolution A.160(ES.IV), and paragraph 10 of regulation II/1 of the International Convention on Standards of Training, Certification and Watchkeeping for Seafarers, 1978, Administrations are recommended to require that the manoeuvring information given herewith is on board and available to navigators.

1.2 The manoeuvring information should be presented as follows:

- .1 Pilot card
- .2 Wheelhouse poster
- .3 Manoeuvring booklet.

2 APPLICATION

2.1 The Administration should recommend that manoeuvring information, in the form of the models contained in the appendices, should be provided as follows:

- .1 for all new ships to which the requirements of the 1974 SOLAS Convention, as amended, apply, the pilot card should be provided;
- .2 for all new ships of 100 metres in length and over, and all new chemical tankers and gas carriers regardless of size, the pilot card, wheelhouse poster and manoeuvring booklet should be provided.

2.2 The Administration should encourage the provision of manoeuvring information on existing ships, and ships that may pose a hazard due to unusual dimensions or characteristics.

2.3 The manoeuvring information should be amended after modification or conversion of the ship which may alter its manoeuvring characteristics or extreme dimensions.

3 MANOEUVRING INFORMATION

3.1 Pilot card (appendix 1)

The pilot card, to be filled in by the master, is intended to provide information to the pilot on boarding the ship. This information should describe the current condition of the ship, with regard to its loading, propulsion and manoeuvring equipment, and other relevant equipment. The contents of the pilot card are available for use without the necessity of conducting special manoeuvring trials.

3.2 Wheelhouse poster (appendix 2)

The wheelhouse poster should be permanently displayed in the wheelhouse. It should contain general particulars and detailed information describing the manoeuvring characteristics of the ship, and be of such a size to ensure ease of use. The manoeuvring performance of the ship may differ from that shown on the poster due to environmental, hull and loading conditions.

3.3 Manoeuvring booklet (appendix 3)

The manoeuvring booklet should be available on board and should contain comprehensive details of the ship's manoeuvring characteristics and other relevant data. The manoeuvring booklet should include the information shown on the wheelhouse poster together with other available manoeuvring information. Most of the manoeuvring information in the booklet can be estimated but some should be obtained from trials. The information in the booklet may be supplemented in the course of the ship's life.

APPENDIX 1

PILOT CARD

Ship's name _____ Date _____

Call sign _____ Deadweight _____ tonnes Year built _____

Draught aft _____m/____ft ____in, Forward _____m/____ft ____in, Displacement _____tonnes

SHIP'S PARTICULARS		
Length overall _____m,	Anchor chain: Port _____shackles,	Starboard _____shackles,
Breadth _____m	Stern _____shackles	
Bulbous bow Yes/No	(1 shackle = _____m/_____fathoms)	

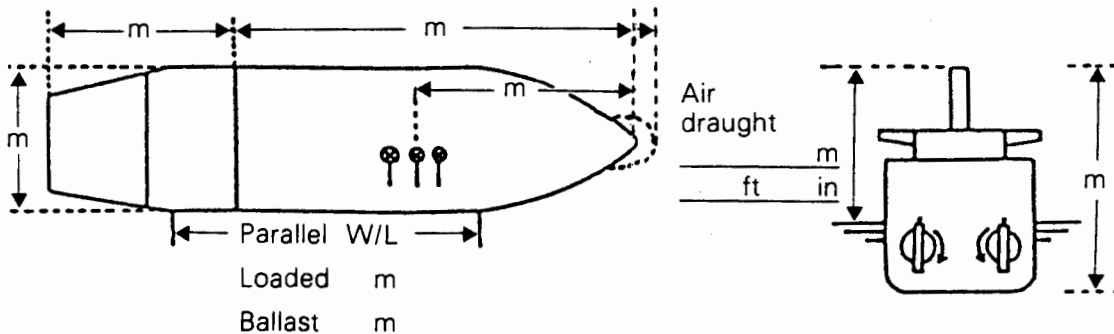

Type of engine _____		Maximum power _____kW (_____HP)	
Manoeuvring engine order	Rpm/pitch	Speed (knots)	
		Loaded	Ballast
Full ahead			
Half ahead			
Slow ahead			
Dead slow ahead			
Dead slow astern		Time limit astern _____min	
Slow astern		Full ahead to full astern _____s	
Half astern		Max. no. of consec. starts _____	
Full astern		Minimum RPM _____ knots	
		Astern power _____% ahead	

APPENDIX 1 (continued)

STEERING PARTICULARS	
Type of rudder _____	Maximum angle _____ °
Hard-over to hard-over _____ s	
Rudder angle for neutral effect _____ °	
Thruster: Bow _____ kW (_____ HP)	Stern _____ kW (_____ HP)

CHECKED IF ABOARD AND READY

Anchors	<input type="checkbox"/>	Indicators:	
Whistle	<input type="checkbox"/>	Rudder	<input type="checkbox"/>
Radar	<input type="checkbox"/> 3 cm	Rpm/pitch	<input type="checkbox"/>
	<input type="checkbox"/> 10 cm	Rate of turn	<input type="checkbox"/>
ARPA	<input type="checkbox"/>	Compass system	<input type="checkbox"/>
Speed log	<input type="checkbox"/>	Constant gyro error	± _____ °
	Doppler: Yes/No	VHF	<input type="checkbox"/>
Water speed	<input type="checkbox"/>	Elec. pos. fix. system	<input type="checkbox"/>
Ground speed	<input type="checkbox"/>		
Dual-axis	<input type="checkbox"/>	Type _____	
Engine telegraphs	<input type="checkbox"/>		
Steering gear	<input type="checkbox"/>		
Number of power units operating	<input type="checkbox"/>		

OTHER INFORMATION:

WHEELHOUSE POSTER

Ship's name _____, Call sign _____, Gross tonnage _____, Net tonnage _____
 Max. displacement _____ tonnes, and Deadweight _____ tonnes, and Block coefficient _____ at summer full load draught

ANCHOR CHAIN	
	Max. rate of heaving (min/shackle)
No. of shackles	
Port	
Starboard	
Stern	
(1 shackle = _____ m/ _____ fathoms)	

STEERING PARTICULARS	
Type of rudder(s) _____	
Maximum rudder angle _____ °	
Time hard-over to hard-over _____ s	
with one power unit _____ s	
with two power units _____ s	
Minimum speed to maintain course propeller stopped _____ knots	
Rudder angle for neutral effect _____ °	

Draught at which the manoeuvring data were obtained

Loaded	Ballast
Trial/Estimated	Trial/Estimated
_____m forward	_____m forward
_____m aft	_____m aft

APPENDIX 2

PROPULSION PARTICULARS		
Type of engine _____, _____ kW (____ HP),	Type of propeller _____	
	Rpm/pitch setting	Speed (knots)
Engine order	Loaded	Ballast
Full sea speed		
Full ahead		
Half ahead		
Slow ahead		
Dead slow ahead		
Dead slow astern		
Slow astern		
Half astern		
Full astern		
Critical revolutions _____ rpm		
Minimum rpm _____ knots		
Time limit astern _____ min		
Time limit at min. revs. _____ min		
Emergency full ahead to full astern _____ s		
Stop to full astern _____ s		
Astern power _____ % ahead		
Max. no. of consecutive starts _____		

THRUSTER EFFECT at trial conditions					
Thruster	kW (HP)	Time delay for full thrust	Turning rate at zero speed	Time delay to reverse full thrust	Not effective above speed
Bow		s	°/min	min s	knots
Stern		s	°/min	min s	knots
Combined		s	°/min	min s	knots

DRAUGHT INCREASE (LOADED)			
Estimated Squat Effect		Heel Effect	
Under keel clearance	Ship's speed (knots)	Max. bow squat estimated (m)	Heel angle (degree)
			2
m			4
			8
			12
m			16
			Draft increase (m)

APPENDIX 2 (continued)

<p>MAN OVERBOARD RESCUE MANOEUVRE</p>	<p>SEQUENCE OF ACTIONS TO BE TAKEN:</p> <ul style="list-style-type: none"> • TO CAST A LIFEBOUY • TO GIVE THE HELM ORDER • TO SOUND THE ALARM • TO KEEP THE LOOK-OUT
<p>Insert a recommended turn</p>	

Prepared by _____
Date _____

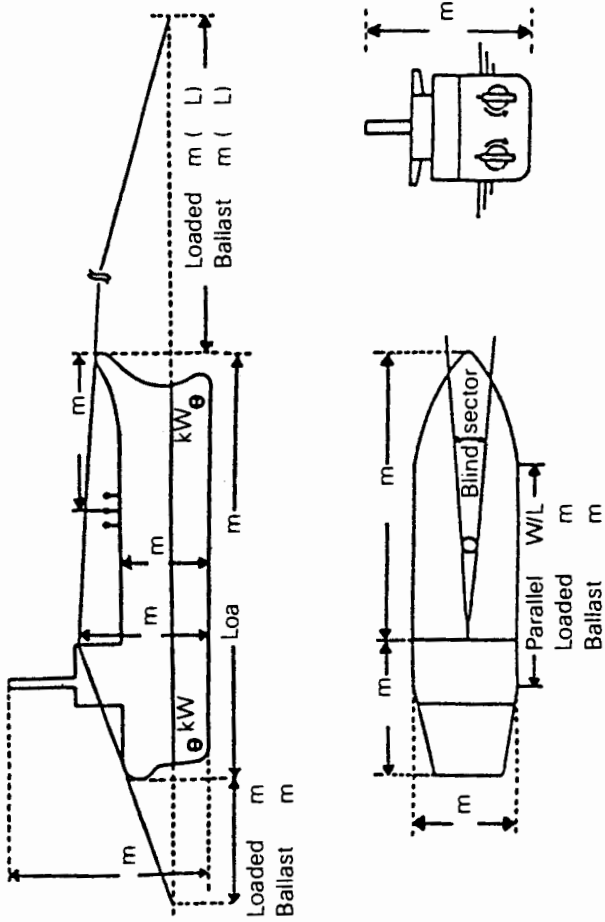

PERFORMANCE MAY DIFFER FROM THIS RECORD DUE TO ENVIRONMENTAL, HULL AND LOADING CONDITIONS

APPENDIX 3

RECOMMENDED INFORMATION TO BE INCLUDED IN THE MANOEUVRING BOOKLET

CONTENTS

- 1 GENERAL DESCRIPTION
 - 1.1 Ship's particulars
 - 1.2 Characteristics of main engine

- 2 MANOEUVRING CHARACTERISTICS IN DEEP WATER
 - 2.1 Course change performance
 - 2.2 Turning circles in deep water
 - 2.3 Accelerating turn
 - 2.4 Yaw checking tests
 - 2.5 Man-overboard and parallel course manoeuvres
 - 2.6 Lateral thruster capabilities

- 3 STOPPING AND SPEED CONTROL CHARACTERISTICS IN DEEP WATER
 - 3.1 Stopping ability
 - 3.2 Deceleration performance
 - 3.3 Acceleration performance

- 4 MANOEUVRING CHARACTERISTICS IN SHALLOW WATER
 - 4.1 Turning circle in shallow water
 - 4.2 Squat

- 5 MANOEUVRING CHARACTERISTICS IN WIND
 - 5.1 Wind forces and moments
 - 5.2 Course-keeping limitations
 - 5.3 Drifting under wind influence

- 6 MANOEUVRING CHARACTERISTICS AT LOW SPEED

- 7 ADDITIONAL INFORMATION

1 GENERAL DESCRIPTION

1.1 Ship's particulars

1.1.1 General

Ship's name, distinctive number or letters, year of build

1.1.2 Gross tonnage and other information

Gross tonnage, deadweight and displacement (at summer draught)

1.1.3 Principal dimensions and coefficients

Length overall, length between perpendiculars, breadth (moulded), depth (moulded), summer draught, normal ballast draught, hull coefficients at summer load and normal ballast condition

Extreme height of the ship's structure above the keel

1.1.4 Main engine

Type, number of units and power output

1.1.5 Propeller

Type, number of units, diameter, pitch, direction of rotation, propeller immersion

1.1.6 Rudder

Type, number of units, total rudder area, rudder area ratio (full load and normal ballast)

1.1.7 Bow and stern thrusters

Type, number of units, capacities and location

1.1.8 Bow and stern profiles

1.1.9 Forward and after blind zones with dimensions specified (full load and normal ballast)

1.1.10 Other hull particulars

Projected areas of longitudinal and lateral above-water profiles (full load and normal ballast)

Length of parallel middle body for berthing (full load and normal ballast)

1.2 Characteristics of main engine

- 1.2.1 Manoeuvring speed tables (trial or estimated, at the full load and ballast conditions)
Engine revolutions, ship speed and thrust (at ahead) corresponding to engine orders
- 1.2.2 Critical revolutions
- 1.2.3 Time for effecting changes in engine telegraph settings as in 3.1.2 for both routine and emergency conditions
- 1.2.4 Time limit astern
- 1.2.5 Minimum operating revolutions (for diesel engines) and corresponding ship speed
- 1.2.6 Maximum number of consecutive starts (for diesel engines)

2 MANOEUVRING CHARACTERISTICS IN DEEP WATER

2.1 Course change performance

- 2.1.1 Initial turning test results (trial or estimated, at the full load and ballast conditions), test conditions, diagrams of heading angle versus time and ship's track
- 2.1.2 Course change test results (trial or estimated, at full load and ballast conditions)
Curves of course change distance and point of initiation of counter rudder for the necessary course change angle (for both full load and ballast conditions)

2.2 Turning circles in deep water (trial or estimated, at the full load and ballast conditions)

- 2.2.1 Turning circle test results
Test conditions, test results (advance and transfer) and turning track at full sea speed ahead
 - 2.2.1.1 Turning circles in both full load and ballast conditions (stern track should be shown)
 - 2.2.1.2 The data presented should refer to the case of starboard turn only (unless there is significant difference for port turn)
 - 2.2.1.3 The initial speed of the ship should be full sea speed ahead
 - 2.2.1.4 Times and speeds at 90°, 180°, 270° and 360° turning should be specifically shown together with an outline of the ship
 - 2.2.1.5 The rudder angle used in the test should be the maximum rudder angle

2.3 Accelerating turn (trial or estimated)

- 2.3.1 Data are to be presented for both full load and ballast conditions in the same manner as 2.2 for turning circles. The ship accelerates from rest with the engine full manoeuvring speed ahead and the maximum rudder angle

2.4 Yaw checking tests (trial or estimated)

- 2.4.1 Results of the zig-zag and pull-out manoeuvre tests at the full load or ballast condition shown as diagrams of the heading changes and rudder angle

2.5 Man-overboard and parallel course manoeuvres

- 2.5.1 Man-overboard manoeuvre (trial)
Diagrams for cases of both starboard and port turns should be shown for both full load and ballast conditions

- 2.5.2 Parallel course manoeuvre (estimated)

Diagrams showing lateral shift to a parallel course using maximum rudder angle

2.6 Lateral thruster capabilities (trial or estimated)

- 2.6.1 Diagrams of turning performance at zero forward speed in the full load or ballast condition should be shown, for bow and stern thrusters acting separately and in combination

- 2.6.2 Diagrams showing the effect of forward speed on turning performance should be included

- 2.6.3 Information on the effect of wind on turning performance should be given

3 STOPPING AND SPEED CONTROL CHARACTERISTICS IN DEEP WATER

3.1 Stopping ability

- 3.1.1 Stopping test results (trial)

Test conditions, ship's tracks, rpm, speed, track reach, head reach and side reach

Two or more tests should be carried out including a test of full astern from full sea speed ahead and a test of full astern from full ahead speed

3.1.2 Stopping ability (estimated)

Information and diagrams should be given of the track reach, head reach, side reach, time required and track reach deceleration factor (distance/one knot reduction) of a ship in both full load and ballast conditions covering the following modes of stopping manoeuvres:

full astern from full sea speed ahead
full astern from full ahead speed
full astern from half ahead speed
full astern from slow ahead speed
stop engine from full sea speed ahead
stop engine from full ahead speed
stop engine from half ahead speed
stop engine from slow ahead speed

3.2 Deceleration performance (estimated)

3.2.1 Deceleration ability (estimated)

Information and diagrams should be given concerning the track reach, time required and deceleration factor of the ship in both full load and ballast conditions for the following engine orders:

full sea speed to "stand by engines"
full ahead to half ahead
half ahead to slow ahead
slow ahead to dead slow ahead

3.3 Acceleration performance (estimated)

3.3.1 Information and diagrams should be given for track reach and time for the ship to achieve full sea speed ahead, from zero speed

4 MANOEUVRING CHARACTERISTICS IN SHALLOW WATER

4.1 Turning circle in shallow water (estimated)

4.1.1 Turning circle in the full load condition (stern track to be shown)

4.1.2 The initial speed of the ship should be half ahead

4.1.3 Times and speeds at 90°, 180°, 270° and 360° turning should be specifically shown, together with an outline of the ship

4.1.4 The rudder angle should be the maximum and the water depth to draught ratio should be 1.2

4.2 Squat (estimated)

- 4.2.1 Curves should be drawn for shallow water and infinite width of channel, indicating the maximum squat versus ship speed for various water depth/draught ratios
- 4.2.2 Curves should be drawn for shallow and confined water, indicating the maximum squat versus speed for different blockage factors

5 MANOEUVRING CHARACTERISTICS IN WIND

5.1 Wind forces and moments (estimated)

- 5.1.1 Information should be given on the wind forces and moments acting on the ship for different relative wind speeds and directions in both full load and ballast conditions, to assist in berthing

5.2 Course-keeping limitation (estimated)

- 5.2.1 Information should be given for both full load and ballast conditions, showing the effect of wind on the ability of the ship to maintain course

5.3 Drifting under wind influence (estimated)

- 5.3.1 Information should be given on the drifting behaviour under wind influence with no engine power available

6 MANOEUVRING CHARACTERISTICS AT LOW SPEED (TRIAL OR ESTIMATED)

- 6.1 Information on the minimum operating revolutions of the main engine and corresponding ship's speed should be given
- 6.2 Information on the minimum speed at which the ship can maintain course while still making headway after stopping engines

7 ADDITIONAL INFORMATION

- 7.1 Any other relevant additional information should be added to the contents of the booklet, particularly information concerned with the operation of the bridge manoeuvring controls.