

Hot Water Deicing of Aircraft: Phase 2



Prepared for

Transportation Development Centre
On behalf of
Civil Aviation
Safety and Security
Transport Canada

and

The Federal Aviation Administration
William J. Hughes Technical Center



November 2000

Hot Water Deicing of Aircraft: Phase 2



by

Peter Dawson
and
Medhat Hanna



November 2000

The contents of this report reflect the views of APS Aviation Inc. and not necessarily the official view or opinions of the Transportation Development Centre of Transport Canada.

The Transportation Development Centre does not endorse products or manufacturers. Trade or manufacturers' names appear in this report only because they are essential to its objectives.

Since some of the accepted measures in the industry are imperial, metric measures are not always used in this report.

DOCUMENT ORIGIN AND APPROVAL RECORD

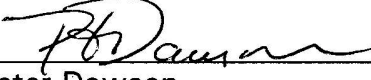
Prepared by:	 Peter Dawson Consultant	<u>16 Jul 2003</u> Date
And by:	Medhat Hanna	

Reviewed by: 
John D'Avirro
Program Manager

Jul 16, 03
Date

Approved by: 
R.V. Potter, Ph.D.
Vice-President Programs & QA

16 July 03
Date

Un sommaire français se trouve avant la table des matières.

PREFACE

Under contract to the Transportation Development Centre of Transport Canada, APS Aviation Inc. has undertaken a research program to advance aircraft ground de/anti-icing technology. The specific objectives of the APS test program are the following:

- To develop holdover time data for Type IV fluids using lowest-qualifying viscosity samples, and to develop holdover time data for all newly qualified de/anti-icing fluids;
- To conduct flat plate holdover time tests under conditions of frost;
- To further evaluate the flow of contaminated fluid from the wing of a Falcon 20D aircraft during simulated takeoff runs;
- To determine the patterns of frost formation and of fluid failure initiation and progression on the wings of commercial aircraft;
- To evaluate whether the proposed locations of Allied Signal's wing-mounted ice sensors on an Air Canada CL65 are optimally positioned;
- To evaluate the second generation of the NCAR snowmaking system;
- To evaluate the capabilities of ice detection camera systems;
- To examine the feasibility of and procedures for performing wing inspections with a remote ice detection camera system at the entrance to the departure runway (end-of-runway);
- To reassemble and prepare the JetStar aircraft wing for mounting, to modify it to obtain cold-soak capabilities, and to conduct fluid failure tests in natural precipitation using the wing;
- To extend hot water deicing tests to aircraft in natural outdoor precipitation conditions, and to correlate outdoor data with 1998-99 laboratory results;
- To examine safety issues and concerns of forced air deicing systems; and
- To evaluate snow weather data from previous winters to establish a range of snow precipitation suitable for the evaluation of holdover time limits.

The research activities of the program conducted on behalf of Transport Canada during the 1999-2000 winter season are documented in nine reports. The titles of these reports are as follows:

- TP 13659E Aircraft Ground De/Anti-icing Fluid Holdover Time and Endurance Time Testing Program for the 1999-2000 Winter;
- TP 13660E Aircraft Full-Scale Test Program for the 1999-2000 Winter: Evaluation of the Positioning of Surface-Mounted Ice Detection Sensors on the Bombardier CL-65 Aircraft;

- TP 13661E A Second-Generation Snowmaking System: Prototype Testing;
- TP 13662E Ice Detection Sensor Capabilities for End-of-Runway Wing Checks: Phase 2 Evaluation;
- TP 13663E Hot Water Deicing of Aircraft: Phase 2;
- TP 13664E Safety Issues and Concerns of Forced Air Deicing Systems;
- TP 13665E Snow Weather Data Evaluation (1995-2000);
- TP 13666E Contaminated Aircraft Simulated Takeoff Tests for the 1999-2000 Winter: Preparation and Procedures; and
- TP 13667E Preparation of JetStar Wing for Use in Deicing Research.

This report, TP 13663E, has the following objective:

- To extend hot water deicing tests to aircraft in natural outdoor precipitation conditions, and to correlate outdoor data with 1998-99 laboratory results.

This objective was addressed by a series of tests to be conducted on aircraft surfaces in natural precipitation. Test parameters included temperature, wind, and active precipitation (rate and type). Due to a lack of suitable conditions, only one test session was conducted, and this was carried out with a snow gun.

ACKNOWLEDGEMENTS

This research has been funded by the Civil Aviation Group, Transport Canada, with support from the US Federal Aviation Administration. This program could not have been accomplished without the participation of many organizations. APS would therefore like to thank the Transportation Development Centre of Transport Canada, the Federal Aviation Administration, National Research Council Canada, the Meteorological Service of Canada, and several fluid manufacturers. Special thanks are extended to US Airways Inc., Air Canada, the National Centre for Atmospheric Research, AéroMag 2000, Aéroports de Montreal, G. Vestergaard A/S, Hudson General Aviation Services Inc., Union Carbide, Cryotech, BFGoodrich, Cox and Company Inc., Fortier Transfert Ltée, and MTN Snow Equipment Inc. for provision of personnel and facilities and for their co-operation with the test program. APS would also like to acknowledge the dedication of the research team, whose performance was crucial to the acquisition of hard data. The authors gratefully acknowledge the contribution of the APS Aviation test team: Nicolas Blais, Michael Chaput, Marc Hunt, Marc Mayodon, Elio Ruggi, Yagusha Bodnar, and Don Robitaille. Special thanks are extended to Frank Eyre and Barry Myers of the Transportation Development Centre for their participation, contribution, and guidance in the preparation of this document.



1. Transport Canada Publication No. TP 13663E		2. Project No. 9789		3. Recipient's Catalogue No.		
4. Title and Subtitle Hot Water Deicing of Aircraft: Phase 2				5. Publication Date November 2000		
				6. Performing Organization Document No. CM1589-001		
7. Author(s) Peter Dawson and Medhat Hanna				8. Transport Canada File No. ZCD2450-23-14 (DC-182)		
9. Performing Organization Name and Address APS Aviation Inc. 1100 René Lévesque Blvd. West Suite 1340 Montreal, Quebec Canada H3B 4N4				10. PWGSC File No. XSD-9-01714		
				11. PWGSC or Transport Canada Contract No. T8200-9-9563/001/XSD		
12. Sponsoring Agency Name and Address Transportation Development Centre (TDC) 800 René Lévesque Blvd. West Suite 600 Montreal, Quebec H3B 1X9				13. Type of Publication and Period Covered Final		
				14. Project Officer Barry B. Myers		
15. Supplementary Notes (Funding programs, titles of related publications, etc.) Research reports produced on behalf of Transport Canada for testing during previous winters are available from the Transportation Development Centre (TDC). Nine reports (including this one) were produced as part of this winter's research program. Their subject matter is outlined in the preface.						
16. Abstract A 1998-1999 laboratory study to further examine environmental limits for the application of hot water as the first-step fluid in a two-step deicing procedure concluded that hot water could be used safely in ambient temperatures colder than those currently authorized. This study also suggested new potential limits. This report describes supplementary aircraft field trials conducted during the 1999-2000 winter season to authenticate the previous results. Due to lack of suitable weather conditions, only one test session was conducted. That test was made possible through use of a commercial snowmaking machine normally used for ski hills. Insufficient data was collected to definitively support the conclusions from the 1998-1999 laboratory trials. Observations were noted regarding the effect of operator spray technique and the increased quantities of fluid on the interval until refreeze following fluid spray.						
17. Key Words Hot water deicing, first-step fluid, ice contamination, two-step fluid application, freezing pattern				18. Distribution Statement Limited number of copies available from the Transportation Development Centre		
19. Security Classification (of this publication) Unclassified		20. Security Classification (of this page) Unclassified		21. Declassification (date) —	22. No. of Pages xx, 56, apps	23. Price Shipping/ Handling



1. N° de la publication de Transports Canada TP 13663E		2. N° de l'étude 9789		3. N° de catalogue du destinataire	
4. Titre et sous-titre Hot Water Deicing of Aircraft: Phase 2				5. Date de la publication Novembre 2000	
				6. N° de document de l'organisme exécutant CM1589-001	
7. Auteur(s) Peter Dawson et Medhat Hanna				8. N° de dossier - Transports Canada ZCD2450-23-14 (DC-182)	
9. Nom et adresse de l'organisme exécutant APS Aviation Inc. 1100, boul. René-Lévesque Ouest Bureau 1340 Montréal, Québec Canada H3B 4N4				10. N° de dossier - TPSGC XSD-9-01714	
				11. N° de contrat - TPSGC ou Transports Canada T8200-9-9563/001/XSD	
12. Nom et adresse de l'organisme parrain Centre de développement des transports (CDT) 800, boul. René-Lévesque Ouest Bureau 600 Montréal (Québec) H3B 1X9				13. Genre de publication et période visée Final	
				14. Agent de projet Barry B. Myers	
15. Remarques additionnelles (programmes de financement, titres de publications connexes, etc.) <p>Les rapports de recherche produits au nom de Transports Canada sur les essais réalisés au cours des hivers antérieurs peuvent être obtenus auprès du Centre de développement des transports (CDT). Le programme de la saison hivernale a donné lieu à neuf rapports (dont celui-ci). On trouvera dans la préface l'objet de ces rapports.</p>					
16. Résumé <p>Une étude en laboratoire, menée en 1998-1999, a scruté les conditions environnementales limites autorisant l'emploi d'eau chaude pour la première étape d'une procédure de dégivrage à deux étapes. Cette étude a mené à la conclusion qu'il est possible d'utiliser l'eau chaude à des températures ambiantes plus basses que celles qui sont présentement autorisées, sans porter atteinte à la sécurité. De nouvelles conditions environnementales limites ont également été suggérées.</p> <p>Le présent rapport rend compte d'essais complémentaires réalisés sur le terrain, sur une voilure d'aéronef, au cours de l'hiver 1999-2000. Ces essais devaient permettre de valider les résultats obtenus précédemment.</p> <p>Des conditions météorologiques défavorables, à l'hiver 1999-2000, ont permis de réaliser un seul essai, avec une machine à fabriquer de la neige commerciale, normalement utilisée sur les pentes de ski. Les données recueillies ne sont pas suffisantes pour valider de façon certaine les conclusions issues des essais en laboratoire de 1998-1999. Des observations ont toutefois été faites concernant l'effet de la technique de vaporisation et de l'augmentation des quantités de liquide vaporisé sur le délai de protection contre le gel.</p>					
17. Mots clés Dégivrage à l'eau chaude, liquide appliqué à la première étape, contamination solide, procédure d'application de liquide à deux étapes, modèle d'apparition de la glace				18. Diffusion Le Centre de développement des transports dispose d'un nombre limité d'exemplaires.	
19. Classification de sécurité (de cette publication) Non classifiée		20. Classification de sécurité (de cette page) Non classifiée		21. Déclassification (date) —	22. Nombre de pages xx, 56, ann.
				23. Prix Port et manutention	

EXECUTIVE SUMMARY

Under contract to the Transportation Development Centre of Transport Canada, APS Aviation (APS) undertook a research program, co-sponsored by the U.S. Federal Aviation Administration, to conduct field tests on aircraft to further examine environmental limits for the application of hot water as the first-step fluid in a two-step deicing procedure.

During the 1998-99 winter, APS examined weather limits for hot water deicing in a series of laboratory tests. That study, supported by data from various related tests in previous years, indicated that the currently recommended outside ambient temperature (OAT) limit of -3°C could be lowered further. Field tests on aircraft would provide important evidence to authenticate the results of the 1998-99 laboratory tests.

Background

Hot water has been authorized and used as an aircraft ground-deicing agent for many years. Its application offers significant benefits to the operator, primarily reduced impact on the environment and fewer operating costs. Despite these potential benefits, hot water is not used as commonly as it has been in the past. At least one reason is the restrictive temperature limitation imposed upon hot water as a deicing agent.

In the past, when hot water deicing enjoyed greater popularity, the lower temperature limit was lower than that now authorized (-7°C versus -3°C). Consequently, the procedure was applied to a greater segment of the deicing operation.

The standard method for deicing with hot water involves removal of the contaminant with a hot water spray that has a temperature at the nozzle of at least 60°C , followed by an overspray of anti-icing fluid, which must be applied before the first-step fluid freezes – typically within 3 minutes.

The intent of the OAT limitation is to allow the deicing operator at least 3 minutes to apply the second-step (anti-icing) fluid before freezing occurs. In operational practice, the spray operator must monitor progress to ensure that no surface area refreezes before the anti-icing fluid is applied. As no freeze point depressant (FDP) is present, the delay in refreezing is only due to the heat that has been transferred to the aircraft surface from the hot water.

Previous related studies include *Hot Water De-icing Trials for the 1994-1995 Winter*, TP 12653E (1), and a study carried out during the 1997-98 winter season, *Aircraft Deicing Fluid Freeze Point Buffer Requirements: Deicing Only*

and *First Step of Two-Step Deicing*, TP 13315E (2). Further investigation of deicing-only fluid application was conducted during the 1998-99 winter season and findings published in the report *Aircraft Deicing Fluid Freeze Point Buffer Requirements for Deicing Only Conditions*, TP 13478E (3). During the 1998-99 winter season, environmental limits for the application of hot water as the first-step fluid in a two-step deicing procedure were further examined and reported in *Hot Water Deicing of Aircraft*, TP 13483E (4).

The 1998-99 laboratory study of hot water deicing concluded that hot water could be used safely during ambient temperatures colder than now authorized. It suggested that potential limits for use of hot water as a first-step fluid be considered as follows:

- To -6° C in wind conditions up to 10 km/h and
- To -3° C with no wind restrictions.

Field tests included as part of the test design to provide confirmation of the 1998-99 laboratory findings were not conducted. The 1999-2000 winter project was planned to complete the study and included exploring the beneficial effect of applying additional amounts of hot water, following the initial cleaning of the wing, on elapsed time to onset of freezing.

The objectives of the 1999-2000 project were to:

- extend hot water deicing tests to aircraft in natural outdoor precipitation conditions;
- study the effect of varying the quantity of hot water; and
- correlate test results with data from 1998-99 laboratory trials.

Results and Conclusions

Due to a lack of suitable weather conditions, only one test session was conducted. That test was made possible through the use of a commercial snowmaking machine normally used for ski hills. Insufficient data was collected to provide confirmation of the 1998-99 laboratory trials. However, other conclusions could be drawn from the results:

Spray Technique: The pattern of progressive freezing over the wing surface showed that special attention needs to be given to ensure that an adequate amount of spray is directed at the wing edges in order to achieve desired intervals until refreeze. This is probably as true for operational deicing with FPD fluids as it is for hot water deicing.

Effect of Increased Quantity of Hot Water: Results demonstrated that a larger quantity of hot water produced a longer time to refreeze. Further tests are needed to fully understand the beneficial effect. As well, the optimum spray pattern to transfer heat to the wing should be investigated.

Use of the Snowmaker: Although natural snow is preferred, the snow generated by the snow gun is adequate for hot water tests, provided that the OAT is colder than -5°C to avoid the problem of wet snow adherence.

Use of the Test Wing: The test wing is a satisfactory surface for these tests, although supplementary tests on operational aircraft are recommended. The absence of fuel in the test wing may have affected the results (because heat transfer from the hot water to the wing surface could be affected by the amount and location of the fuel) and this should be investigated.

It is recommended that field tests on operational aircraft and on the test wing be completed during the 2000-01 winter season.

This page intentionally left blank.

SOMMAIRE

À la demande du Centre de développement des transports de Transports Canada et de la U.S. Federal Aviation Administration, APS Aviation (APS) a entrepris des essais sur le terrain, sur une voilure d'aéronef, afin d'examiner plus avant les conditions environnementales limites autorisant l'emploi d'eau chaude pour la première étape d'une procédure de dégivrage à deux étapes.

Au cours de l'hiver 1998-1999, APS avait effectué une série d'essais en laboratoire qui visaient à déterminer les conditions météorologiques limites pour le dégivrage à l'eau chaude. Ces essais ont confirmé ce que divers essais menés au cours des années antérieures avaient montré, à savoir qu'il est possible d'abaisser la limite de la température de l'air extérieur (OAT) actuellement recommandée, soit -3 °C. Des essais sur le terrain mettant en jeu des aéronefs devaient valider de façon non équivoque les résultats des essais en laboratoire de 1998-1999.

Contexte

L'eau chaude est autorisée et utilisée depuis de nombreuses années en tant qu'agent de dégivrage au sol des aéronefs. Son utilisation comporte des avantages certains pour le transporteur, en particulier des impacts minimes sur l'environnement et des coûts réduits. Mais en dépit de ces avantages, l'eau chaude n'est plus utilisée aussi couramment que par le passé, en raison notamment des contraintes liées à la température.

Autrefois, lorsque le dégivrage à l'eau chaude était plus populaire, la limite inférieure de température autorisant le recours à cette méthode était plus faible que celle qui est maintenant autorisée (-7 °C par rapport à -3 °C). Elle était donc utilisée pour une plus grande proportion des opérations de dégivrage.

La méthode standard de dégivrage à l'eau chaude consiste à ôter la contamination avec un jet d'eau chaude dont la température à la sortie de la buse est d'au moins 60 °C et à pulvériser ensuite un liquide antigivrage avant que l'eau gèle, normalement dans les trois minutes.

Cette limitation de l'OAT vise à donner au préposé au dégivrage un créneau d'au moins trois minutes pour l'application du deuxième liquide (antigivrage), avant que l'eau gèle. Dans la pratique, le préposé doit surveiller sa progression et s'assurer d'appliquer le liquide antigivrage avant que les surfaces gèlent de nouveau. Comme l'eau utilisée pour le dégivrage ne contient pas d'abaisseur du point de congélation, le délai de protection contre le gel est fonction uniquement de la chaleur transférée par l'eau à la voilure.

Au nombre des études antérieures portant sur le dégivrage à l'eau chaude figurent *Hot Water De-icing Trials for the 1994-1995 Winter*, TP 12653E (1) et une étude menée au cours de l'hiver 1997-1998, *Aircraft Deicing Fluid Freeze Point Buffer Requirements: Deicing Only and First Step of Two-Step Deicing*, TP 13315E (2). D'autres recherches sur la procédure de dégivrage simple ont été réalisées au cours de la saison hivernale 1998-1999. Les résultats ont fait l'objet du rapport *Aircraft Deicing Fluid Freeze Point Buffer Requirements for Deicing Only Conditions*, TP 13478E (3). Au cours de la saison hivernale 1998-1999, les conditions environnementales limites autorisant l'emploi d'eau chaude pour la première étape d'une procédure de dégivrage à deux étapes ont été scrutées. Le rapport *Hot Water Deicing of Aircraft*, TP 13483E (4), découle de cette étude.

La conclusion qui s'est dégagée de l'étude en laboratoire de 1998-1999 est qu'il est possible d'utiliser l'eau chaude à des températures ambiantes plus basses que celles qui sont présentement autorisées, sans porter atteinte à la sécurité. Les conditions limites ci-après pour l'emploi d'eau chaude ont également été suggérées :

- Jusqu'à -6 °C, sous des vents d'une vitesse maximale de 10 km/h.
- Jusqu'à -3 °C, quelle que soit la vitesse du vent.

Les essais sur le terrain que prévoyait le protocole pour confirmer les résultats des essais en laboratoire de 1998-1999 n'ont pas été menés. Le projet de l'hiver 1999-2000 a donc été conçu comme un complément de l'étude en laboratoire. Il devait également examiner si le fait d'appliquer de plus grandes quantités d'eau chaude après l'enlèvement de la contamination peut allonger le délai de protection contre le gel.

Les travaux de l'hiver 1999-2000 visaient ce qui suit :

- étendre les essais de dégivrage à l'eau chaude à une voilure d'aéronef, dans des conditions de précipitations naturelles;
- étudier l'effet de la variation de la quantité d'eau chaude;
- comparer les résultats des essais sur le terrain avec les résultats des essais en laboratoire menés en 1998-1999.

Résultats et conclusions

Des conditions météorologiques défavorables ont permis de réaliser un seul essai, avec une machine à fabriquer de la neige commerciale, normalement utilisée sur les pentes de ski. Les données recueillies ne sont pas suffisantes pour valider les conclusions issues des essais en laboratoire de 1998-1999. D'autres conclusions ont toutefois été tirées de cet essai :

Technique de pulvérisation : La congélation graduelle de l'eau sur la surface de l'aile a montré qu'il importe de bien pulvériser le bord d'attaque et le bord de fuite, pour obtenir le délai voulu de protection contre le gel. Cela est probablement aussi vrai pour les opérations de dégivrage qui font appel à des liquides contenant un abaisseur de point de congélation que pour celles qui utilisent de l'eau chaude.

Effet de l'augmentation de la quantité d'eau chaude : Les résultats ont révélé que plus la quantité d'eau pulvérisée est grande, plus le délai de protection contre le gel est long. Il faudra d'autres essais pour bien comprendre cet effet bénéfique. Il y aura également lieu d'étudier la technique de pulvérisation optimale pour transférer le maximum de chaleur à la voilure.

Utilisation de la machine à fabriquer de la neige : Bien que la neige naturelle soit toujours préférable à la neige artificielle, la neige fabriquée par la machine convient aux essais, à condition que la température de l'air extérieur soit inférieure à -5 °C, sans quoi la neige mouillée poserait un problème d'adhérence.

Utilisation de l'aile d'essai : L'aile d'essai constitue un outil satisfaisant pour ces essais, même s'il est recommandé de mener des essais complémentaires à l'aide d'aéronefs en service. L'absence de carburant dans l'aile d'essai peut avoir influé sur les résultats (car le transfert de chaleur de l'eau chaude à la surface de l'aile peut être influencé par la quantité et l'emplacement du carburant dans l'aile). Il y a donc lieu d'approfondir cette question.

Il est recommandé, pour l'hiver 2000-2001, de mener des essais sur le terrain à l'aide d'aéronefs en service et de l'aile d'essai.

This page intentionally left blank.

CONTENTS

	Page
1. INTRODUCTION AND RESULTS FROM PREVIOUS STUDIES	1
1.1 Background	1
1.1.1 Hot Water Deicing Trials for the 1994-1995 Winter, TP 12653E	2
1.1.2 Aircraft Deicing Fluid Freeze Point Buffer Requirements: Deicing Only and First Step of Two-Step Deicing, TP 13315E (1997-98)	3
1.1.3 Aircraft Deicing Fluid Freeze Point Buffer Requirements for Deicing Only Conditions, TP 13478E (1998-99)	8
1.1.4 Hot Water Deicing of Aircraft, TP 13483E (1998-99)	8
1.2 Work Statement	16
1.3 Objectives	16
2. METHODOLOGY	19
2.1 Test Site	19
2.2 Description of Test Procedure	19
2.2.1 Test Preparation	21
2.2.2 Conducting Tests	23
2.3 Equipment	24
2.3.1 The Transport Canada JetStar Test Wing	24
2.3.2 Snowmaker	24
2.3.3 Measuring Snow Depth	25
2.4 Fluids	25
2.5 Personnel	25
2.6 Data Forms	26
3. DESCRIPTION AND PROCESSING OF DATA	35
3.1 Overview of Tests	35
4. ANALYSIS AND OBSERVATIONS	41
4.1 Run 1a.....	41
4.2 Run 1b	41
4.3 Run 2	44
4.4 Run 3	44
5. CONCLUSIONS	51
5.1 Spray Technique	51
5.2 Limits on Use of Hot Water.....	51
5.3 Effect of Quantity of Hot Water.....	51
5.4 Test Procedures	51
5.4.1 Use of the Snowmaker	51
5.4.2 Operator Spray Technique.....	52
5.4.3 Fluid Temperatures	52
5.4.4 Use of the Test Wing	52
6. RECOMMENDATIONS	53
REFERENCES.....	55

LIST OF APPENDICES

- A Excerpt from Transportation Development Centre Work Statement
- B Experimental Program – Field Trials to Establish Weather Limits for Hot Water Deicing
- C Lenko 950 Snow Gun
- D SAE Aerospace Recommended Practice ARP 4737 – Aircraft Deicing/Anti-Icing Methods with Fluids

LIST OF FIGURES

	Page
1.1 Hypothetical Curves – Relating Lag Time to Freezing with OAT for Incremental Wind Speed.....	4
1.2 Time to Onset of Freezing – Hot Water	5
1.3 Temperature Profiles of Test Surface and Dilute Type I FFP	6
1.4 Temperature Profiles of Test Surface and Full Strength Type I FFP	7
1.5 Influence of OAT and Wind on Plate Cooling Rate, <i>Deicing Only</i> Tests, Hot Water.....	9
1.6 Hot Water Deicing Tests – Comparison of Fluid Type	11
1.7 Effect of OAT at Wind = 10 km/h; HOT Type I, ID#70, 46, and 10	12
1.8 Effect of Wind at OAT= -6°C, HOT Type I, (0, 10, 20 km/h)	14
1.9 Effect of Fluid Amount at Wind = 10 km/h, OAT= -12°C, Hot Water (306, 510, 1 020 mL).....	15
1.10 Effect of Duration of Contamination Prior to Test, (1.4, 5.4, 10.0 min)	17
3.1 Icing Form for JetStar Wing	38
3.2 Skin Temperature Profiles – Run 3	39
4.1 Skin Temperature Profiles – Run 1a	42
4.2 Skin Temperature Profiles – Run 1b	43
4.3 Skin Temperature Profiles – Run 2	45
4.4 Skin Temperature Profiles – Run 3	47
4.5 Pattern of Freezing Times on the Test Wing – Run 3	48

LIST OF TABLES

	Page
2.1 Test Plan – Field Tests for Hot Water Deicing Limits	20
3.1 Log of Hot Water Tests, March 10-11, 2000	36

LIST OF PHOTOS

	Page
2.1 Hot Water Test Set-up	27
2.2 JetStar Test Wing	27
2.3 Test Wing on Snow-Covered Ramp.....	29
2.4 Lenko Snow Gun at Flat Elevation	29
2.5 Lenko Snow Gun – Elevated	31
2.6 Type of Snow on Wing Trailing Edge.....	31
2.7 Measuring Snow Depth with Scale.....	33
2.8 Measuring Snow Depth with Paint Gauge	33

GLOSSARY

APS	APS Aviation Inc.
APU	Auxiliary Power Unit
CDF	Central Deicing Facility
FAA	Federal Aviation Administration
FFP	Fluid Freeze Point
FPD	Freeze Point Depressant
NCAR	National Centre for Atmospheric Research
NRC	National Research Council Canada
OAT	Outside Air Temperature
SAE	Society of Automotive Engineers, Inc.
TDC	Transportation Development Centre

This page intentionally left blank.

1. INTRODUCTION AND RESULTS FROM PREVIOUS STUDIES

Under contract to the Transportation Development Centre (TDC) of Transport Canada, APS Aviation (APS) undertook a research program, co-sponsored by the U.S. Federal Aviation Administration (FAA), involving field tests on aircraft to further examine environmental limits for the application of hot water as the first-step fluid in a two-step deicing procedure.

During the 1998-99 winter, APS examined weather limits for hot water deicing in a series of laboratory tests. That study, supported by data from various related tests in previous years, indicated that the ambient temperature limit of -3°C currently recommended in SAE Aerospace Recommended Practice ARP 4737 (given in Appendix D) could be lowered. Therefore, it was expected that field tests on aircraft would provide important evidence to authenticate the results of the 1998-99 laboratory tests.

1.1 Background

Hot water has been authorized and used as an aircraft ground-deicing agent for many years. Its application offers significant benefits to the operator, primarily reduced impact on the environment and reduced operating costs. Despite these potential benefits, hot water is not used as commonly as it has been in the past. One reason is the restrictive limitation on minimum temperature. In the past, when hot water deicing enjoyed greater popularity, the temperature limit was lower than that now authorized (-7°C versus -3°C). Consequently, the procedure was applied to a greater segment of the deicing operation.

The standard method for deicing with hot water involves removal of the contaminant with a hot water spray that has a temperature at the nozzle of at least 60°C , followed by an overspray of anti-icing fluid. The SAE Aerospace Recommended Practice ARP 4737 defines this methodology and states that the anti-icing fluid is to be applied before the first-step fluid freezes – typically within three minutes. It also establishes limits on ambient weather conditions for use of hot water as a first-step fluid: the outside air temperature (OAT) must be no lower than -3°C . There is no reference to wind as a limiting factor.

The intent of the lower limit on OAT is to allow the deicing operator at least three minutes to apply the second-step (anti-icing) fluid before refreezing occurs. In operational practice, the spray operator must monitor progress to ensure that no surface area refreezes before the anti-icing fluid is applied. As no freeze point depressant (FPD) is present when water is used as a

first-step fluid, the delay in refreezing is due only to the heat that has been transferred to the aircraft surface from the hot water.

In the past, when hot water was used more widely and before the advent of the modern SAE Type IV fluids, the second-step anti-icing spray generally consisted of a heated Type I fluid. Currently, Type IV anti-icing fluids are applied unheated. This change in operational environment is an important consideration as a heated second-step fluid could be viewed as serving a natural corrective function for any early freezing of the water application not noted by the operator.

Previous related studies include *Hot Water Deicing Trials for the 1994-1995 Winter, TP 12653E* (1), and a study carried out during the 1997-98 winter season, *Aircraft Deicing Fluid Freeze Point Buffer Requirements: Deicing Only and First Step of Two-step Deicing, TP 13315E* (2). Further investigation of deicing-only fluid application was conducted during the 1998-99 winter season and findings published in the report *Aircraft Deicing Fluid Freeze Point Buffer Requirements for Deicing Only Conditions, TP 13478E* (3). Also during the 1998-99 winter season, environmental limits for the application of hot water as the first-step fluid in a two-step deicing procedure were further examined and reported in *Hot Water Deicing of Aircraft, TP 13483E* (4).

1.1.1 Hot Water Deicing Trials for the 1994-1995 Winter, TP 12653E

This study examined whether the OAT limit for the application of hot water could be safely lowered below -3°C . Results of the study, conducted primarily on aircraft and in dry conditions, indicated that hot water deicing is feasible at OAT below -3°C , depending on wind speed and operator disciplines. Earliest occurrence of freezing occurred on flight control surfaces at the rear of the wing, rather than the main wing surface. It was recommended that any further tests should examine composite materials frequently used in the fabrication of various wing surfaces. Subsequent laboratory tests confirmed the major influence of high winds to shorten the time until the start of freezing. Field operators experienced with the hot water deicing process stated that a cautious approach is necessary during high winds, even at moderate temperatures.

The study proposed a model that might be used to determine operational limits for the combination of OAT and wind. A family of hypothetical curves was proposed that could potentially define the relationship

between lag time and OAT for various incremental wind speeds. This model is shown in Figure 1.1.

1.1.2 Aircraft Deicing Fluid Freeze Point Buffer Requirements: Deicing Only and First Step of Two-Step Deicing, TP 13315E (1997-98)

This study examined the application of heated Type I deicing fluids, as well as water, and determined the resultant interval until freezing initiated. Tests were conducted at various temperatures under precipitation conditions of freezing rain and freezing drizzle. A test procedure for combining wind and precipitation conditions was devised, and a small number of tests at one OAT were conducted. Figure 1.2 charts *lag times* (time until the onset of freezing) versus OAT. Data for different wind speeds were generated at only one OAT.

The study also examined the rate of dilution of the applied Type I fluids under the test levels of precipitation. Test results demonstrated that the heat transferred to the test surface from the heated first-step fluid accounted for the major part of the interval before start of refreezing. Type I fluids experienced rapid dilution after application and the remaining freeze point depressant extended the safe period to a limited extent depending on the rate of dilution.

Figure 1.3 is a plot of surface temperature and fluid freeze point over time. The surface rapidly heats with the application of hot water and then cools, and the fluid freeze point rises as the fluid is diluted under ongoing precipitation. In the test reported in Figure 1.3, the Type I fluid was mixed to the currently approved limit for first-step fluids wherein the fluid freeze point may be 3°C warmer than OAT. Figure 1.4 plots the same data for an neat Type I fluid, and demonstrates how quickly a fluid, which is initially in its standard concentration, is diluted to the point where its freeze point is equal to OAT.

The *deicing only* aspect of this study examined the use of very dilute fluids to remove any contamination after periods of precipitation had ended. The rate of cooling of the test surface for different wind and OAT combinations was measured, but in dry conditions. This information is useful because it provides an indication of the time interval following application of the heated deicing fluid until the surface temperature reaches 0°C, for various OAT/wind combinations.

FIGURE 1.1
HYPOTHETICAL CURVES - RELATING LAG TIME TO FREEZING WITH OAT
FOR INCREMENTAL WIND SPEED

HOT WATER DEICING TESTS
 NO PRECIPITATION
 March - April 1995

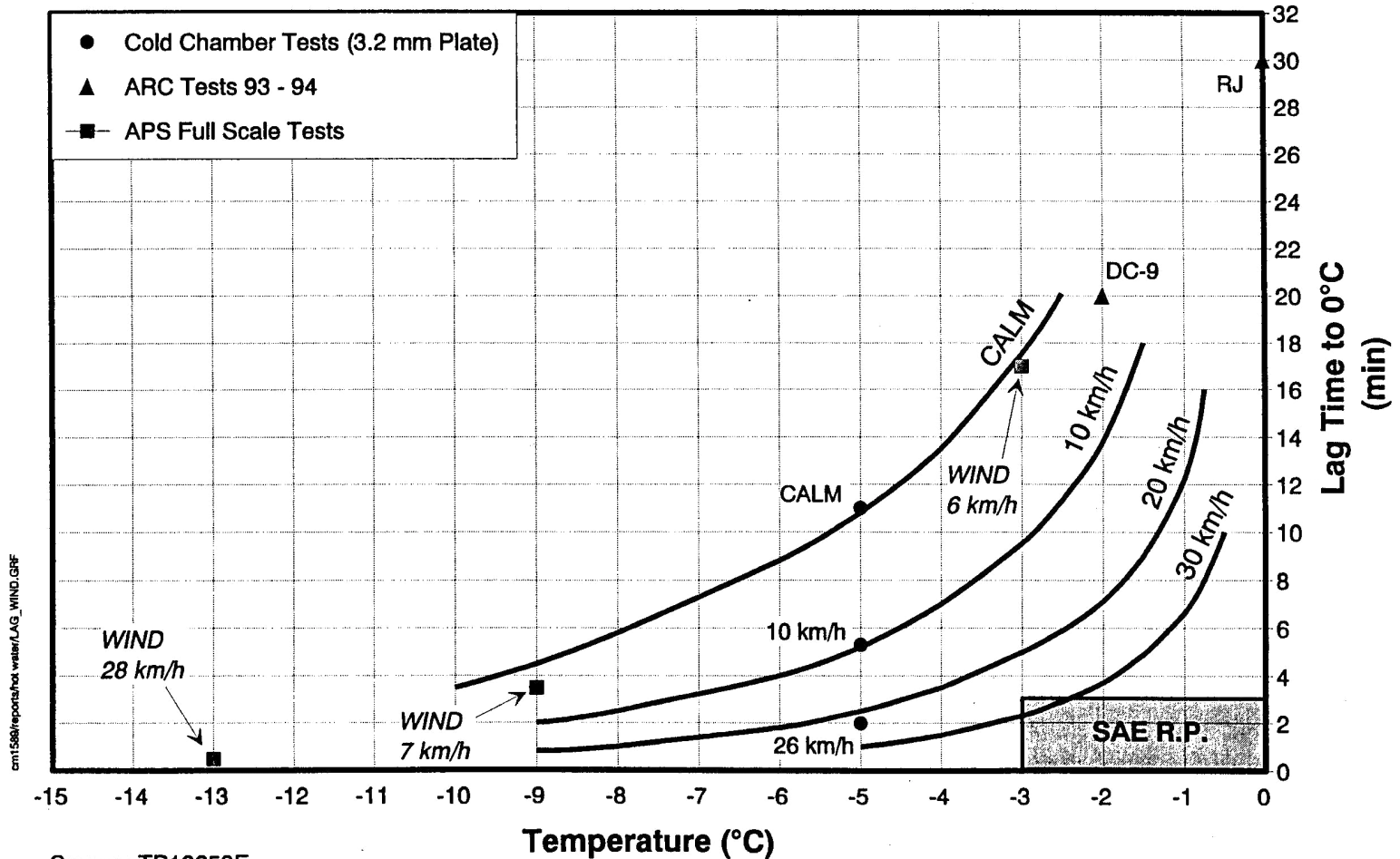

Source: TP12653E

FIGURE 1.2
FIRST STEP FLUID TESTS IN 1997-98
TIME TO ONSET OF FREEZING - HOT WATER
LIGHT FREEZING RAIN (25g/dm²/hr)

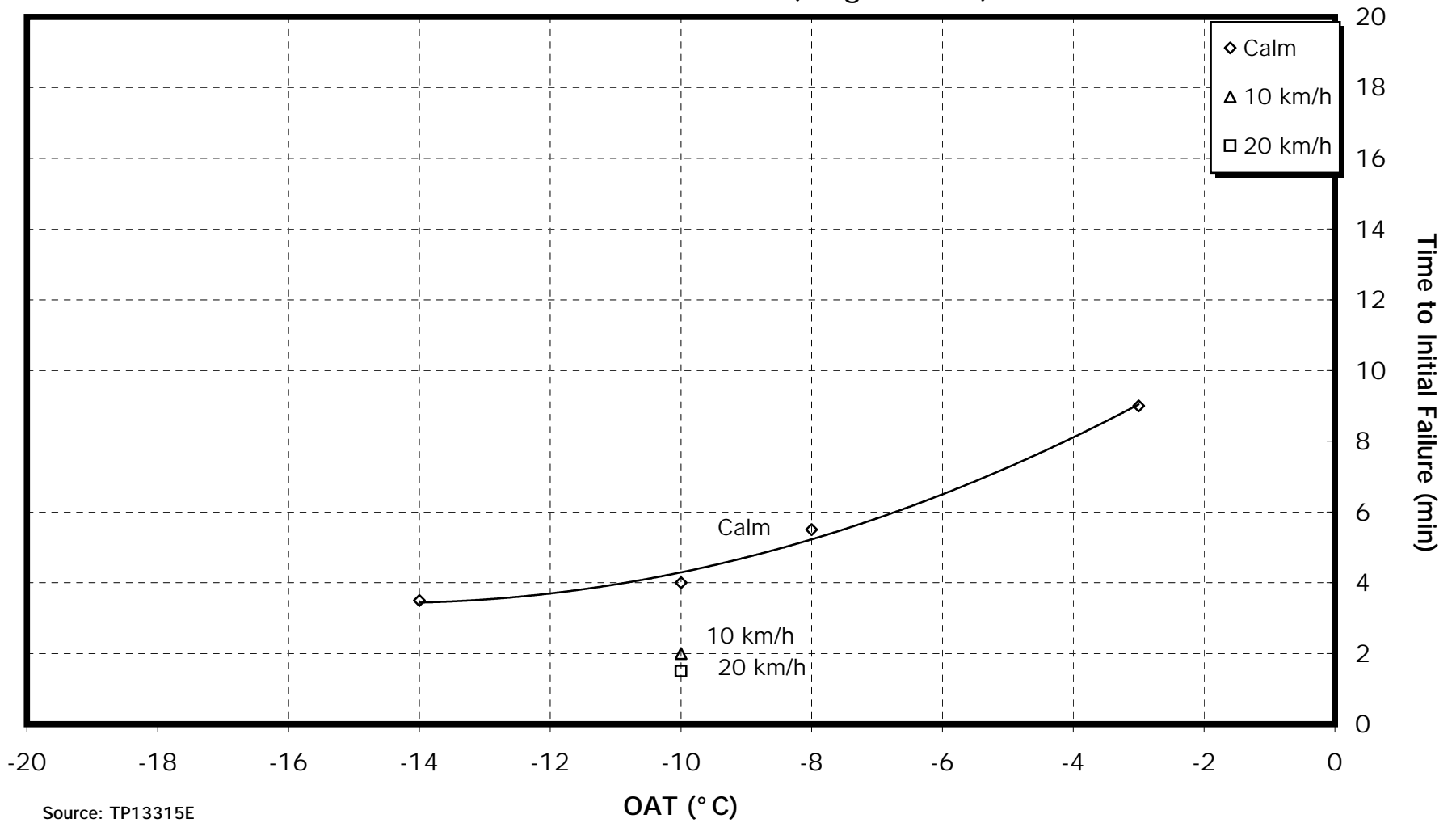

Source: TP13315E

FIGURE 1.3
 FIRST STEP FLUID TESTS IN 1997-98
TEMPERATURE PROFILES OF TEST SURFACE AND DILUTE TYPE I FFP
 LIGHT FREEZING RAIN (25 g/dm²/hr), OAT = -10°C
 Type I Fluid Diluted to a Freeze Point of -7°C

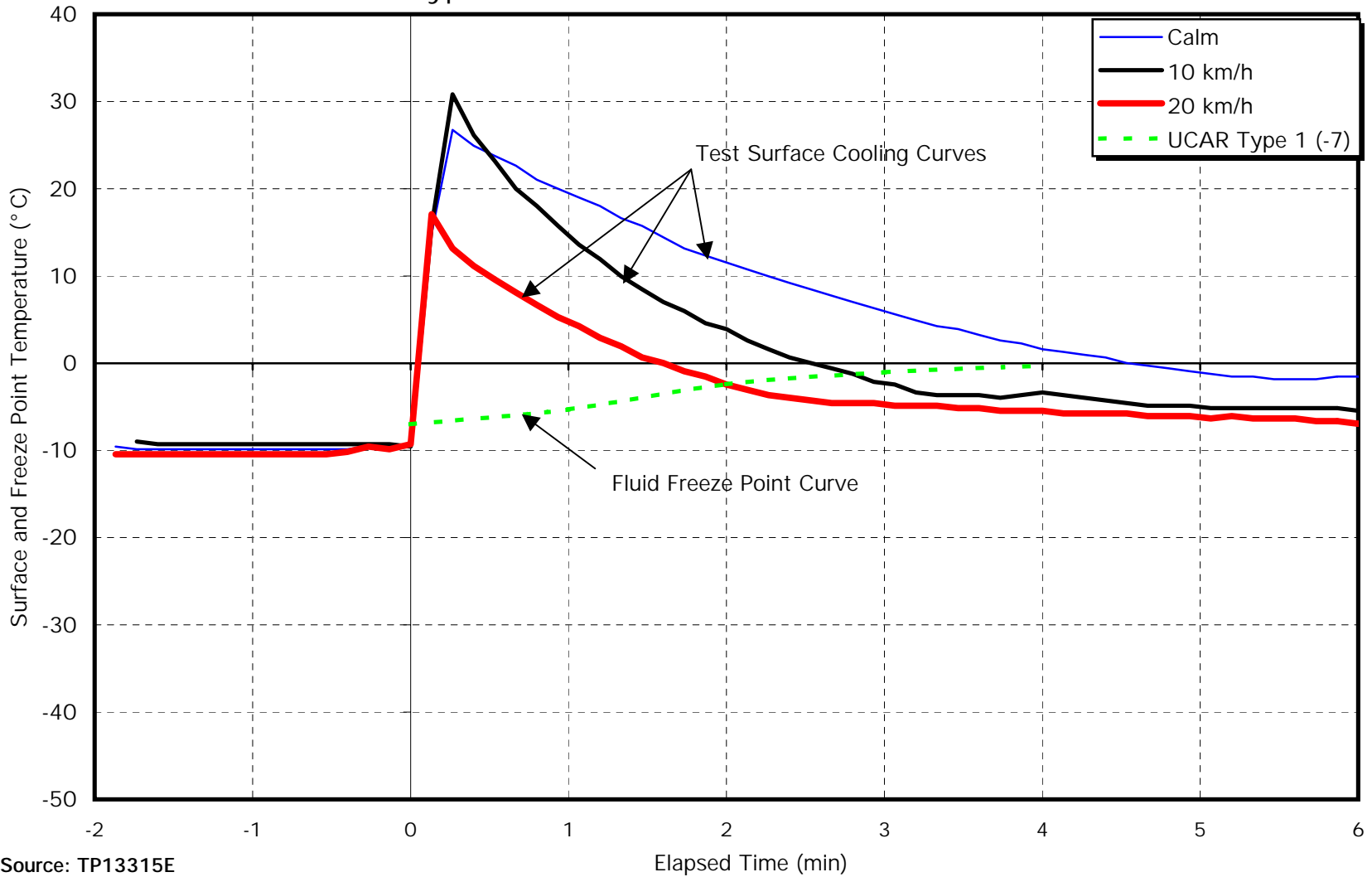

Source: TP13315E

FIGURE 1.4
 FIRST STEP TESTS 1997-98
 TEMPERATURE PROFILES OF TEST SURFACE AND FULL
 STRENGTH TYPE I FFP
 LIGHT FREEZING RAIN (25 g/dm²/hr), OAT = -10°C

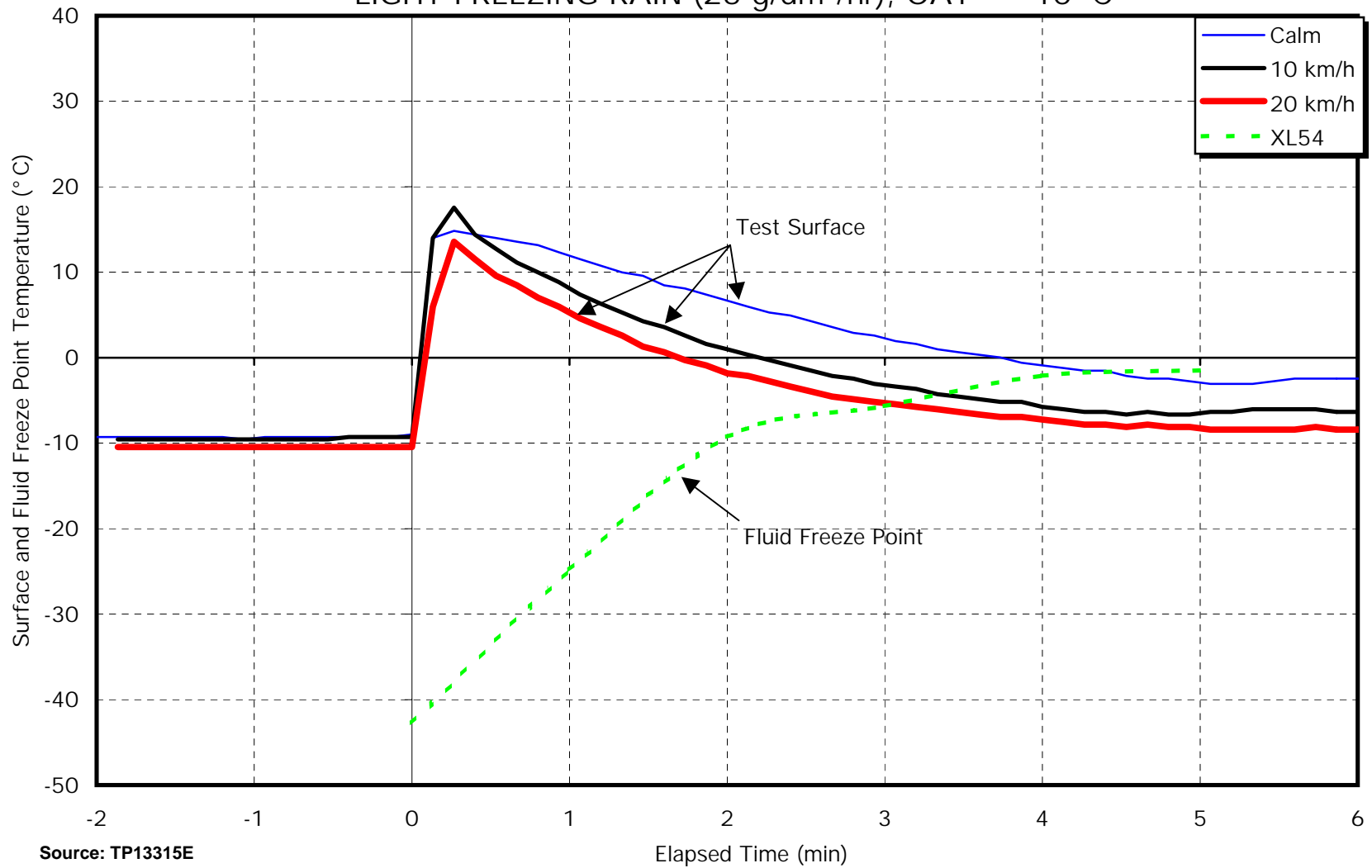

Source: TP13315E

Figure 1.5 charts results obtained from tests using hot water. The time interval (at various wind speeds) until the plate temperature drops to 0° C is plotted versus OAT. Water at 60° C was applied to each clean plate, marking the beginning of each test.

1.1.3 Aircraft Deicing Fluid Freeze Point Buffer Requirements for Deicing Only Conditions, TP 13478E (1998-99)

This further investigation of the *deicing only* application examined the effects of varying several test parameters. One variable examined was the removal of snow contamination from the test surface to ascertain whether the act of removing snow diminished the final transfer of heat to the surface. This factor was examined both in the laboratory and in the field on an aircraft wing. The test methodology was based on actual operations and allowed the spray operator to continue spraying until the surface was clean.

It was concluded that, in general, the greater the amount of contamination, the greater the quantity of fluid that was applied by the operator, and that increased quantity of fluid compensated for any loss of heat in the snow removal process.

1.1.4 Hot Water Deicing of Aircraft, TP 13483E (1998-99)

The objective of this project was to evaluate environmental limits (OAT, wind) for the use of hot water as the first-step fluid in a two-step deicing operation. The study was conducted at the National Research Council Canada Climatic Engineering Facility in Ottawa. Test parameters included temperature, wind, active precipitation, and substrate materials. In addition to hot water, heated deicing fluids (both diluted and at standard strength) were tested to provide a reference case. Standard test plates were fabricated from typical aircraft composite materials as well as from aircraft aluminum. Because heat transfer to the test surface was a key element of the study, the loss of heat related to removal of a surface contaminant was also examined. A controlled amount of contamination was allowed to collect on the plates prior to each test run, by exposing the plate to precipitation for a predetermined time interval. The resulting layer of ice contamination was then removed by spraying as much fluid as was required to produce a clean plate.

FIGURE 1.5
INFLUENCE OF OAT AND WIND ON PLATE COOLING RATE
DEICING ONLY TESTS - HOT WATER
 NO PRECIPITATION

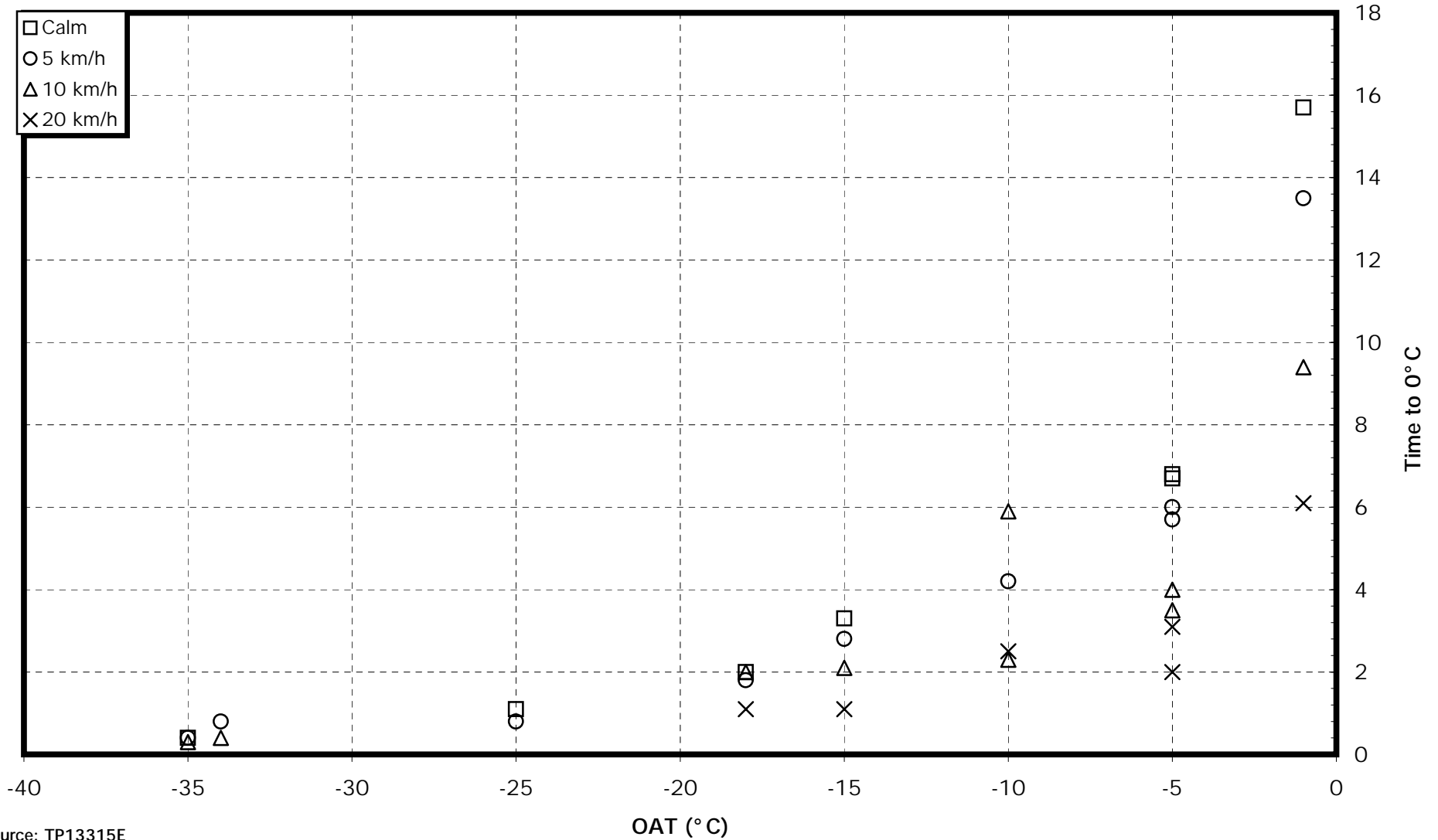

Source: TP13315E

The most critical data measured in these tests were the time intervals between fluid application (spray) and first appearance of ice on test surfaces. An interval of at least three minutes was the key indicator of acceptable temperature and wind limits.

1.1.4.1 Results and Conclusions

The principal conclusion was that hot water provides a period of protection equal to or better than Type I fluids mixed to the approved freeze point, in ambient temperatures as low as -6°C and in winds up to 10 km/h. Figure 1.6 charts the time interval to first appearance of ice as a function of OAT, with winds of 10 km/h.

At -9°C , with winds of 10 km/h, diluted Type I fluid performs slightly better than hot water.

At -3°C , with winds of 20 and 30 km/h, hot water provided a 3-minute period of protection before freezing.

Figure 1.7 provides an explanation for the similar results observed at milder OAT from application of hot water and heated dilute fluid. The solid lines represent plate temperature as it is heated at time of fluid application and then cools toward OAT. The test fluid was mixed to the approved strength for a first-step fluid (freeze point at 3°C above OAT). In the chart, the fluid freeze point (FFP) is seen to progressively (and quickly) rise as the fluid is diluted. First freezing would be expected to occur at the time when the FFP is equal to the plate temperature. Had water been applied, its FFP would be constant at 0°C . The time of intersection of the plate temperature profile with the 0°C line and with the fluid FFP profile are very close for an OAT of -3°C and -6°C .

Figure 1.7 shows that the fluid strength actually improves (demonstrated as a drop in FFP) just following application. This characteristic was studied and observed in the *deicing only* series of tests that were conducted in dry conditions. It is interesting to note that some temporary fluid enhancement occurred even under precipitation. This temporary fluid enhancement actually extended the period of protection offered by the freeze point depressant, and is an additional way that the heat in the applied fluid contributes to the interval until onset of freezing.

Values for elapsed time until freezing were significantly lower in these tests than during previous "first-step fluid" tests because of the differences in test procedures. In the "first-step fluid" tests, 500 mL of

FIGURE 1.6
HOT WATER DEICING TESTS
COMPARISON OF FLUID TYPE
ELAPSED TIME TO FIRST APPEARANCE OF ICE - WINDS 10 km/h
SIMULATED LIGHT FREEZING RAIN (25 g/dm²/h)

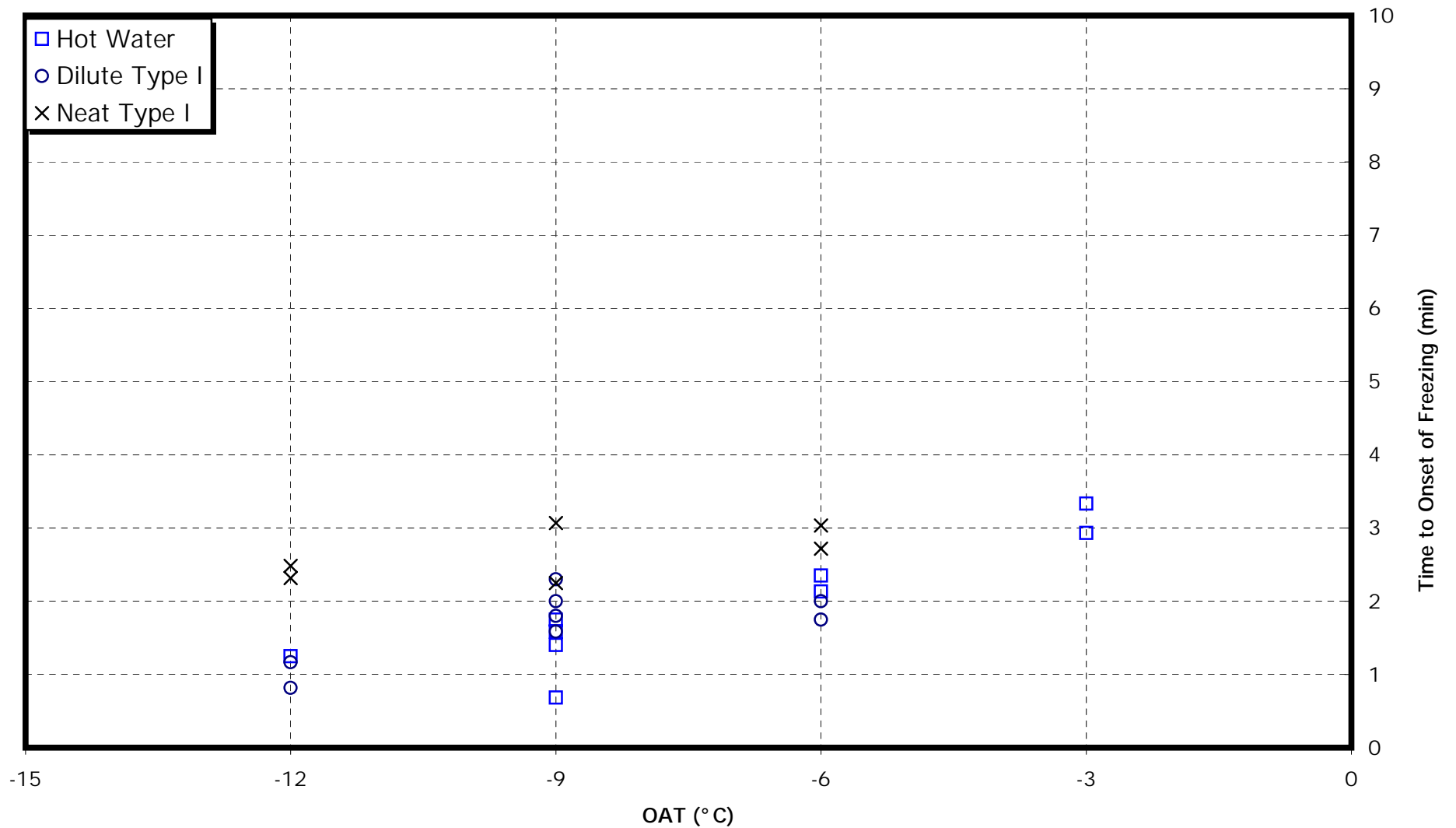
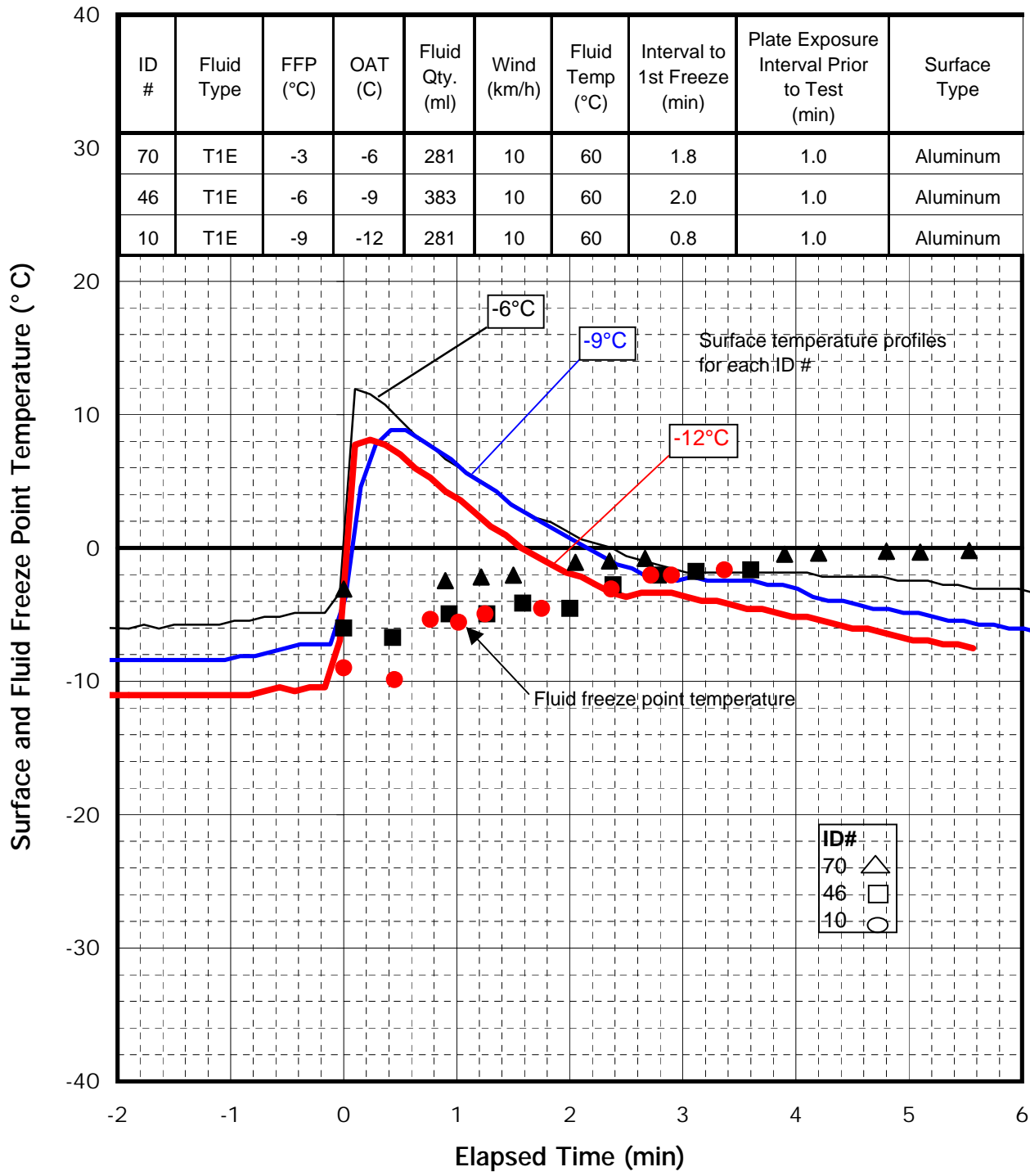

FIGURE 1.7
EFFECT OF OAT AT WIND = 10 km/h, HOT TYPE I
(-6, -9, -12° C)
Simulated Light Freezing Rain (25 g/dm²/hr)



the fluid was applied to a clean test surface, whereas this series of tests required spraying a contaminated plate until it was clean. A much smaller quantity of fluid was applied (ranging from 200 to 300 mL per test plate), which resulted in shorter periods of protection.

The measured intervals until onset of freezing were also considerably shorter than those obtained from field tests on operational aircraft in March-April 1995. Those tests, involving a spray application of hot water onto the aircraft by operators experienced with hot water deicing procedures, were conducted in dry conditions. A review of the test record revealed that operators sprayed varying amounts of hot water, ranging from 20 to 40 gal. (90 to 180 L), on each DC-9 wing tested. This is equivalent to 300 to 600 mL on each test plate area, for an average of 450 mL per application. Again, test quantities in the current series of tests were conservative compared to previous tests and to quantities applied by experienced operators.

The fluid quantities needed to produce clean surfaces on painted composite substrates were significantly less than those required to produce clean surfaces on bare aircraft aluminum substrates. Elapsed times to the onset of freezing for the glass fibre, carbon fibre, and Kevlar composite surfaces were shorter than for the standard aluminum test plate, but equal to or greater than the elapsed times on the aluminum-on-honeycomb-core test surface. The shorter times recorded for composites were at least partly due to the lower fluid quantities necessary to achieve a clean surface. In an operational setting, any composite surfaces integrated into a wing structure would receive the same amount of fluid as the principal aluminum surface and therefore the protection period would be similar.

Aluminum-on-honeycomb-core appeared to be the most critical type of surface, giving the lowest rate of increase in period of protection (interval until onset of freezing) per additional unit of fluid applied.

The effect of wind is shown in Figure 1.8, where the surface temperature profiles show a much more rapid cooling with increased wind, and a shorter interval until intersection of the surface temperature profile with the FFP profile.

The quantity of fluid applied on aluminum substrates for a fixed level of contamination influenced the duration of the period of protection. Figure 1.9 illustrates the extended interval to first freeze as a function of fluid quantity. Tests to investigate the influence of fluid quantity were not conducted on composite surfaces, but it is expected that a similar trend would result.

FIGURE 1.8
**EFFECT OF WIND AT OAT = -6°C, HOT TYPE I
 (0, 10, 20 km/h)**
 Simulated Light Freezing Rain (25 g/dm²/hr)

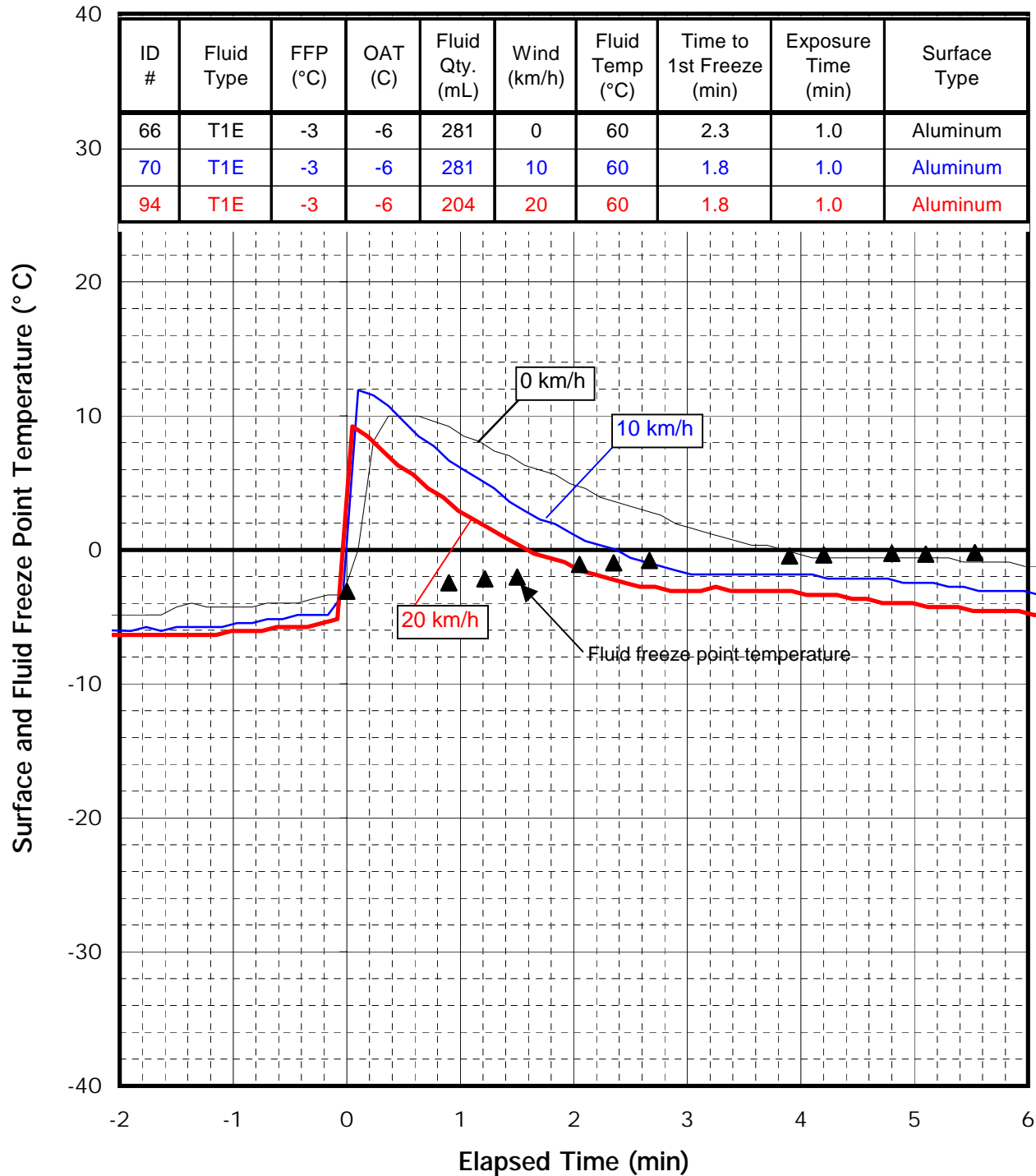
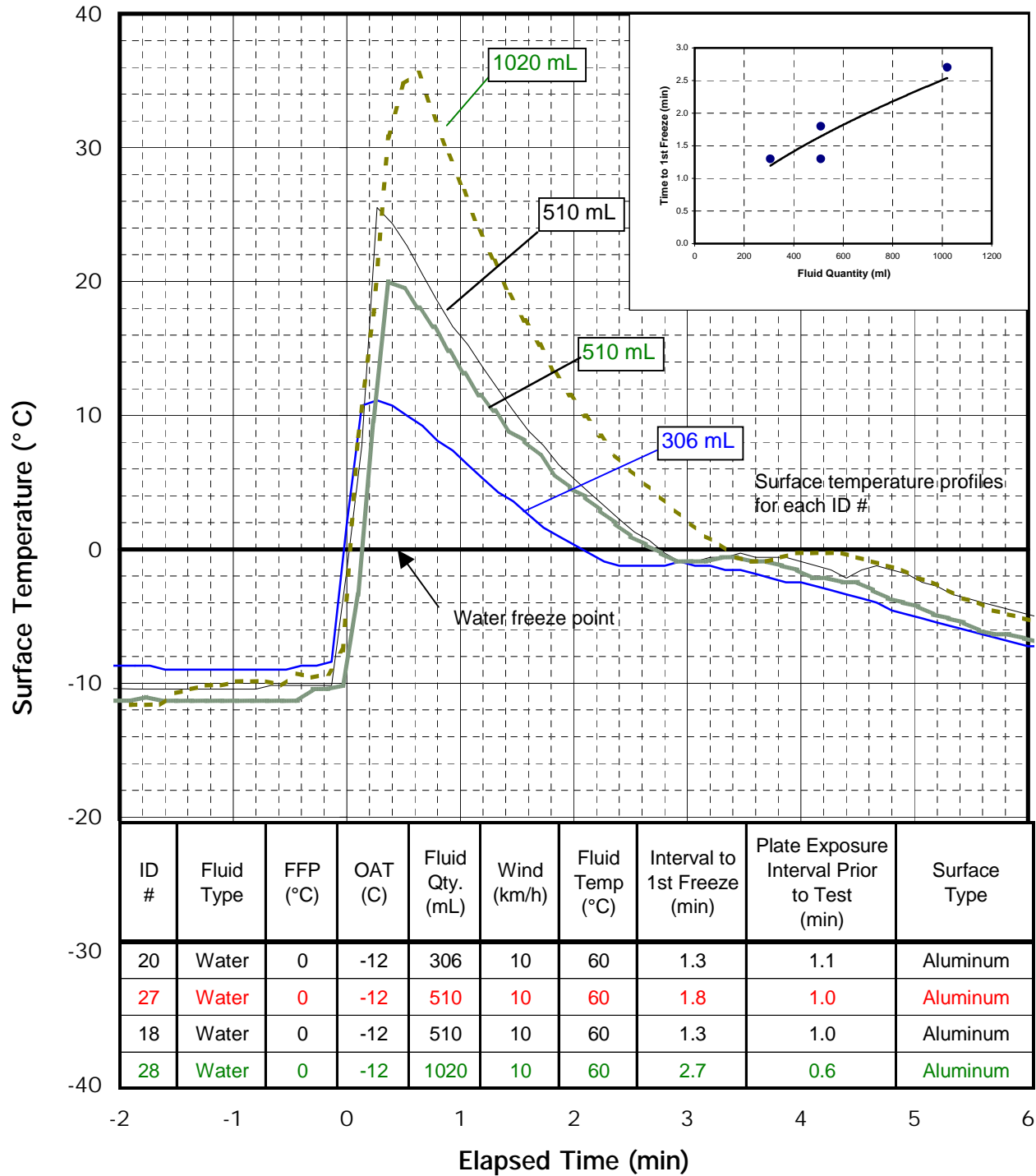

FIGURE 1.9
EFFECT OF FLUID AMOUNT AT WIND = 10 km/h,
OAT = -12°C, HOT WATER
(306, 510, 1020 mL)
Simulated Light Freezing Rain (25 g/dm²/hr)



The extent of contamination (Figure 1.10) did not significantly influence the elapsed time to freezing under the test procedures followed in this study. The fluid heat lost in cleaning away the heavier contamination was compensated for by the application of more fluid.

The 1998-99 laboratory study of hot water deicing concluded that hot water could be used safely during ambient temperatures colder than now authorized. It suggested potential limits for use of hot water as a first-step fluid be considered as follows:

- To -6° C in wind conditions up to 10 km/h and
- To -3° C with no wind restrictions.

Field tests included as part of the test design to provide confirmation of the 1998-99 laboratory findings were not conducted, and the 1999-2000 winter project was planned to complete the study. The beneficial effect on elapsed time to onset of freezing of applying additional amounts of hot water following the initial cleaning of the wing was also to be examined.

1.2 Work Statement

Appendix A presents an excerpt from the project description of the work statement for the APS Aviation 1999-2000 winter research program.

1.3 Objectives

The objectives of the 1999-2000 project were to:

- Extend hot water deicing tests to aircraft in natural outdoor precipitation conditions;
- Study the effect of varying the quantity of hot water; and
- Correlate test results with data from 1998-99 laboratory tests.

FIGURE 1.10
**EFFECT OF DURATION OF CONTAMINATION
 PRIOR TO TEST
 (1.4, 5.4, 10.0 min)**

Simulated Light Freezing Rain (25 g/dm²/hr), OAT -3° C, Calm Wind

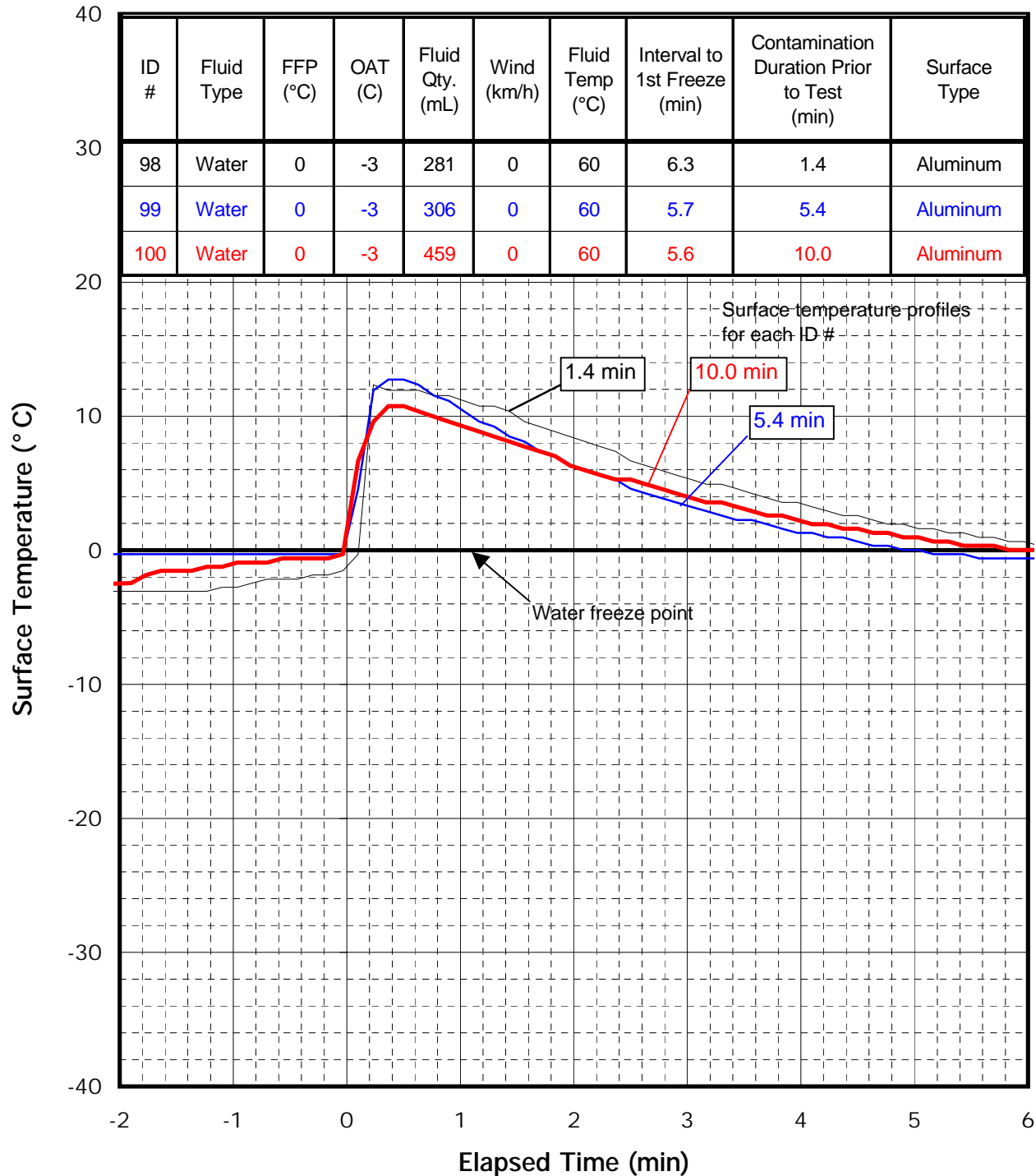

This page intentionally left blank.

2. METHODOLOGY

This section describes the conditions and methodologies planned for these tests, as well as the test equipment and personnel requirements.

2.1 Test Site

Tests were planned to be conducted at the Central Deicing Facility (CDF) at Montreal International Airport (Dorval).

Arrangements were made with AéroMag 2000 to perform the deicing. This role included providing deicing vehicles, preparing them for the tests, preparing fluids to specified concentrations and temperatures, and spraying the wing according to test procedures.

Arrangements were made with US Airways to provide an aircraft for the tests. This involved towing an overnighting aircraft to and from the CDF. An agreement was put in place to cover towing and fuel costs related to Auxiliary Power Unit (APU) operation needed for powering the flight control surfaces. An agreement was put in place to cover aircraft towing and overtime costs related to the participation of an aircraft mechanic.

During the single test session that was conducted, a simultaneous test was run for the end-of-runway project employing a remote ice detector (Cox and Co) mounted on a mobile construction mast.

Photo 2.1 shows the overall test set-up.

2.2 Description of Test Procedure

Four sessions of field tests were planned in precipitation (snow conditions and freezing rain or drizzle) to reflect actual operational deicing conditions. Two test sessions on aircraft and two on the Transport Canada JetStar test wing were planned.

A matrix of planned tests is shown in Table 2.1.

Test conditions desired included OAT in the range of -6 to -12°C with winds from 7 to 15 km/h. Precipitation conditions needed were snow or freezing rain.

TABLE 2.1
TEST PLAN
FIELD TESTS FOR HOT WATER DEICING LIMITS
 Winter 1999-2000

RUN	OAT (°C)	PRECIP. TYPE	FLUID TYPE	FLUID QTY.	FLUID TEMP. (°C)	TEST SURFACE
1	-6 TO -12	Snow	Water	As Rq'd to clean wing	60	Aircraft Wing
2	-6 TO -12	Snow	Water	As Rq'd to clean wing	70	Aircraft Wing
3	-6 TO -12	Snow	Water	Equiv to 1.0 L/plate	60	Aircraft Wing
4	-6 TO -12	Snow	Water	Equiv to 1.5 L/plate	60	Aircraft Wing
5	-6 TO -12	Snow	Dilute T1E	As Rq'd to clean wing	60	Aircraft Wing
6	-6 TO -12	Snow	Neat T1E	As Rq'd to clean wing	60	Aircraft Wing
7	-6 TO -12	Freezing Rain	Water	As Rq'd to clean wing	60	Aircraft Wing
8	-6 TO -12	Freezing Rain	Water	As Rq'd to clean wing	70	Aircraft Wing
9	-6 TO -12	Freezing Rain	Water	Equiv to 1.0 L/plate	60	Aircraft Wing
10	-6 TO -12	Freezing Rain	Water	Equiv to 1.5 L/plate	60	Aircraft Wing
11	-6 TO -12	Freezing Rain	Dilute T1E	As Rq'd to clean wing	60	Aircraft Wing
12	-6 TO -12	Freezing Rain	Neat T1E	As Rq'd to clean wing	60	Aircraft Wing
13	-6 TO -12	Snow	Water	As Rq'd to clean wing	60	Test Wing
14	-6 TO -12	Snow	Water	As Rq'd to clean wing	70	Test Wing
15	-6 TO -12	Snow	Water	Equiv to 1.0 L/plate	60	Test Wing
16	-6 TO -12	Snow	Water	Equiv to 1.5 L/plate	60	Test Wing
17	-6 TO -12	Snow	Dilute T1E	As Rq'd to clean wing	60	Test Wing
18	-6 TO -12	Snow	Neat T1E	As Rq'd to clean wing	60	Test Wing
19	-6 TO -12	Freezing Rain	Water	As Rq'd to clean wing	60	Test Wing
20	-6 TO -12	Freezing Rain	Water	As Rq'd to clean wing	70	Test Wing
21	-6 TO -12	Freezing Rain	Water	Equiv to 1.0 L/plate	60	Test Wing
22	-6 TO -12	Freezing Rain	Water	Equiv to 1.5 L/plate	60	Test Wing
23	-6 TO -12	Freezing Rain	Dilute T1E	As Rq'd to clean wing	60	Test Wing
24	-6 TO -12	Freezing Rain	Neat T1E	As Rq'd to clean wing	60	Test Wing

Note: Test Runs 7, 8 and 9 were conducted.

EQUIVALENT FLUID QUANTITIES BY AIRCRAFT TYPE

Aircraft	Spray Qty.	Total Wing Area (m ²)	Liters/Wing	Gal (US)/Wing	Gal (Imp)/Wing
DC-9	Equiv to 1.0 L/plate	93	310	82	68
DC-9	Equiv to 1.5 L/plate		465	123	102
B737	Equiv to 1.0 L/plate	106	353	93	78
B737	Equiv to 1.5 L/plate		530	140	117
Jetstar	Equiv to 1.0 L/plate	50	168	44	37
Jetstar	Equiv to 1.5 L/plate		252	67	55
RJ	Equiv to 1.0 L/plate	55	182	48	40
RJ	Equiv to 1.5 L/plate		273	72	60

The tests were designed to examine applications of hot water, a Type I deicing fluid mixed to the currently approved buffer level (3°C above OAT), and a standard strength deicing fluid. The temperature and quantity of applied fluid were varied. To examine the beneficial effect of applying greater quantities of heated water (or fluid), the water or fluid spray was to be applied either according to the standard procedure where the contamination is removed in a single pass over the wing, or according to a special procedure wherein a second pass applied an overspray on the cleaned wing.

Data to be collected included:

- Type, quantity, and temperature of fluid applied (fluid temperature to be measured at the tank, the nozzle, and at the wing surface);
- Record of weather conditions and precipitation rate;
- Time and location for freezing to start to appear on wing surfaces;
- Thickness and roughness of any ice formation;
- Examination of wing cavities at flight control surfaces for evidence of ice;
- Temperature history of points on the wing surface;
- Rate of dilution of deicing fluid on the wing surface; and
- Photo and videotape records of test set-up and results.

2.2.1 Test Preparation

An agreement was reached with AéroMag 2000 and with US Airways for their participation in the tests. An alert process was put in place with contact personnel. As well, the services of an aircraft mechanic were planned.

Weather forecasts were monitored by APS to identify suitable conditions for the test, and all participants were advised of the potential for testing.

Participants from AéroMag 2000 were then briefed regarding the fluid mix and temperature requirements. The fluid tank and hoses on the deicing vehicle were flushed in preparation for loading water. The water was loaded and heated to 60°C for the first test.

The team was briefed on test procedures, and individual assignments and data forms were distributed.

US Airways and its ground handler (Ogden Aviation) were contacted to arrange for the aircraft to be towed to the CDF and parked with its nose

into the wind. The wing and test site were then prepared for testing in the following manner:

- Set up mobile light unit and ensure adequate illumination of the wing;
- Set up generators and power cords;
- Set up stairs near the wing;
- Install thermistor probes on the wing;
- Mark wing locations for Brix measurements;
- Test thermistor probes for function and set up data logger;
- Set up test stand to support precipitation rate measurement;
- Position and set up cube van to support precipitation rate measurement, and ensure all cameras are functional; and
- Synchronize all timepieces, loggers, and cameras.

Although weather forecasts were closely monitored during the entire winter season, no suitable weather conditions occurred during the overnight period when the aircraft, AéroMag 2000 facilities, and CDF were available. As the winter progressed and it seemed that the tests might not be performed due to lack of suitable conditions, it was decided to search for an alternative source for snow. Following a search, an arrangement was made with a supplier of snowmaking equipment for ski hills (MTN Snow Equipment Inc.) to provide and operate the snowmaker during hot water tests on the test wing. MTN Snow Equipment was added to the alert list, and its Lenko 950 snowmaker was used to support tests on one overnight test session.

To use the snowmaker, special arrangements were made with the Dorval Airport fire station for access to a fire hydrant beside the fire station and near Pad 5 of the CDF. Because a water hose was run from the fire hydrant to the snowmaker at Pad 5, taxiway Juliet had to be closed for the duration of the test. As the test was run overnight, there were no flight operations in this area. The fire station also provided three lengths of hose (75 m or 250 ft.) sufficient to reach from the hydrant to the test area. Preparation activities for use of the Lenko 950 snow gun are given in Appendix C.

It was decided to take advantage of the hot water test session to conduct tests for end-of-runway use of remote ice detectors. A Cox and Co remote ice detector and supporting equipment was set up at the test site to observe the test wing as it was subjected to snowfall during the test process.

2.2.2 Conducting Tests

The following test procedure applied to aircraft wings and to the JetStar test wing. Services of an aircraft mechanic were not required in tests with the JetStar wing.

For Each Run

- Measure fluid Brix and temperature in truck tank.
- Measure fluid temperature at nozzle, spraying away from wing.
- Deice wing with test fluid. Record amount of fluid applied.
- Tests studying the effect of additional quantities of hot water will require fluid to be applied as follows. The wing will be cleaned from wingtip to fuselage, in conformance with normal procedures. The operator will then spray the specified amount of additional fluid over the cleaned wing, progressing back to the wingtip. In a field operation, application of the second-step anti-icing fluid would commence at this point.
- Record OAT, wind speed and direction, and relative humidity.

Observe Time to Freeze

- Observe wing for first freezing.
 1. If freezing starts less than 3 minutes after spray application, record time of first freezing and location. Three minutes after spray application, record location and pattern of any frozen patches. Measure thickness and roughness of any ice patches.
 2. If more than 3 minutes elapses between spray application and the start of freezing, record time of first freezing and location.
- Measure fluid strength on the wing near specified probe locations (5, 6, 7, 8, 9). Take measurements immediately after fluid application and then every minute during the test run and at test end. Ensure sampled locations are shifted each time to avoid repeated sampling at the same point. Protect the fluid sample from precipitation. Disregard any early freezing caused by the sampling activity.
- Measure precipitation rate and weather conditions during each test run.

Freezing in Wing Cavities

- At test end, mechanic lowers/raises flight control surfaces as necessary to allow inspection for ice formation.
- Observers and mechanic inspect and record any occurrence of ice in cavities. Note its characteristics (thickness or volume, consistency, adherence). Note any effect on movement of the control surface.
- Aircraft mechanic directs the cleaning of any ice from cavities in preparation for the next test.

- Mechanic returns control surfaces to normal configuration.

Prepare for Next Test

- Allow time for the wing to cool to ambient temperature, and for contamination to start to form on wing surfaces.

End of Test Session

- Deice wing with deicing fluid. Mechanic to approve condition for return of aircraft to service.
- Remove thermistor probes from wing.
- Remove any markings from the wing.

Appendix B provides a full description of test procedures.

2.3 Equipment

A list of test equipment is included in Appendix B. Most of the equipment used was standard to previous tests conducted on aircraft. US Airways committed to making one of two overnight Boeing 737 aircraft at Dorval available for tests.

Special mention needs to be made of the test wing and the snowmaker.

2.3.1 The Transport Canada JetStar Test Wing

The test wing was used for the only test session performed during the 1999-2000 winter season. The test wing is described in the report *Preparation of JetStar Wing for Use in Deicing Research*, TP 13667E. The wing proved to be very suitable for this test. Some discussion arose regarding the fact that the wing was empty of fuel. This issue is addressed later in the discussion of test results (Section 4). Photos 2.2 and 2.3 show the test wing in position.

2.3.2 Snowmaker

The use of commercial snowmaking equipment was investigated in view of the unlikelihood of suitable weather conditions occurring during the remainder of the winter season.

Arrangements were made with a local firm, MTN Snow Equipment Inc., for use of a Lenko 950 snow gun for these tests. Details on the sprayer and preparation activities for its use are included in Appendix D.

The snow gun was used during an overnight test session evaluating hot water deicing. OAT was -5°C and wind speed was 8 km/h. The effective rate of production of snow was adjusted by varying the distance from the snowmaker to the wing. It was found that tilting the snow gun up in the air and allowing the arc of snow to drift down over the wing improved snow distribution and resulted in a gentler snowfall. The snow gun is shown in operation in Photos 2.4 and 2.5, directing the stream of generated snow toward the test wing. Snowfall rates were about $20\text{ g/dm}^2/\text{h}$ for later tests in the overnight test session, when the process was somewhat refined.

The snow was in the form of a snow pellet with a diameter of about 1.5 mm. The density of the snow was about 0.3 g/cc. The snow was slightly wet, resulting in immediate and strong adherence to the wing skin. The snow gun equipment supplier, who was present at the tests, commented that a colder OAT is necessary in order to achieve a drier form of snow. Photo 2.6 shows snow accumulation on the wing trailing edge.

Snow generated by this equipment is suitable for the contaminated aircraft takeoff tests, provided that OAT is colder than -5°C . It is expected that its use will deposit snow over a large part of the test aircraft, and may require deicing of aircraft surfaces other than the designated wing test area.

2.3.3 Measuring Snow Depth

A scale calibrated in millimetres (Photo 2.7) was generally used to measure snow depth on the wing. A paint gauge (Photo 2.8) was used for very small amounts.

2.4 Fluids

Water and SAE Type I UCAR ADF fluid (full strength and diluted to first-step limit of 3°C above OAT) were used. Specified fluid temperatures were 60°C and 70°C measured at the spray nozzle.

2.5 Personnel

Eight APS personnel were involved in the test session. One of these was dedicated to support the snowmaker equipment. A ninth member was

present to gather remote ice detector data to support the end-of-runway tests.

Representatives from Transport Canada and FAA were present as observers.

AéroMag 2000 staff prepared the deicing vehicles and fluids for testing, and they sprayed the test wing.

2.6 Data Forms

Data forms included a general form for every test, forms to record Brix measurements from various wing types, forms to record icing locations on various wing types, and a precipitation rate measurement form. These forms are included in Appendix B.

Photo 2.1
Hot Water Test Set-up



Photo 2.2
JetStar Test Wing



Photo 2.3
Test Wing on Snow-Covered Ramp



Photo 2.4
Lenko Snow Gun at Flat Elevation



Photo 2.5
Lenko Snow Gun – Elevated



Photo 2.6
Type of Snow on Wing Trailing Edge



Photo 2.7
Measuring Snow Depth with Scale

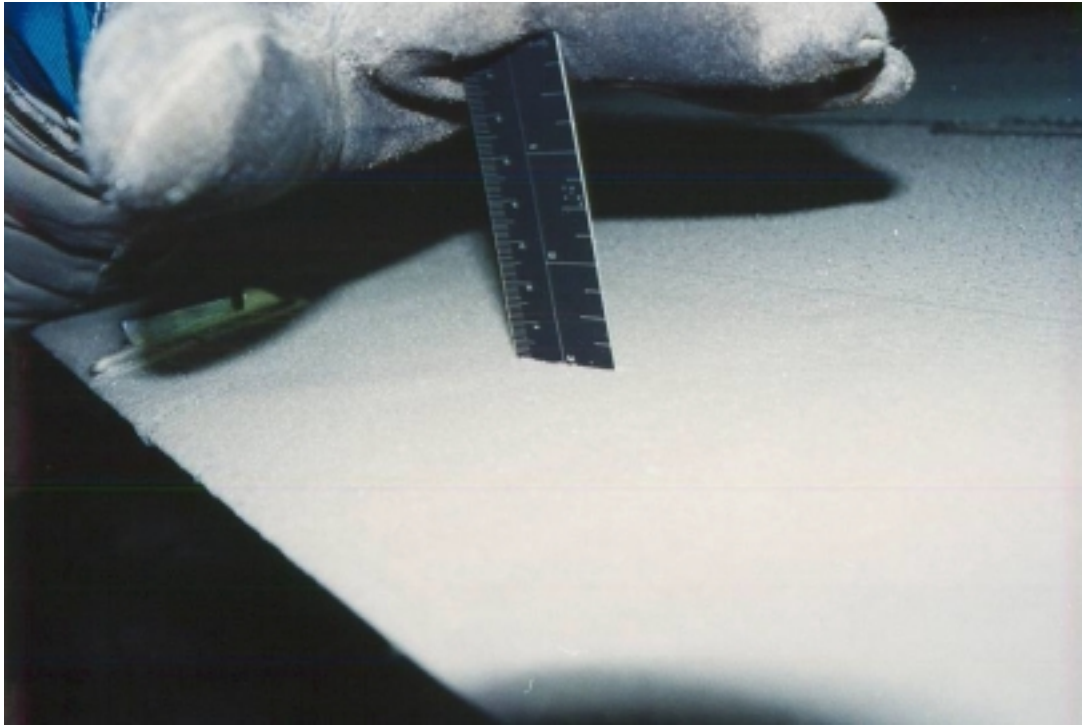
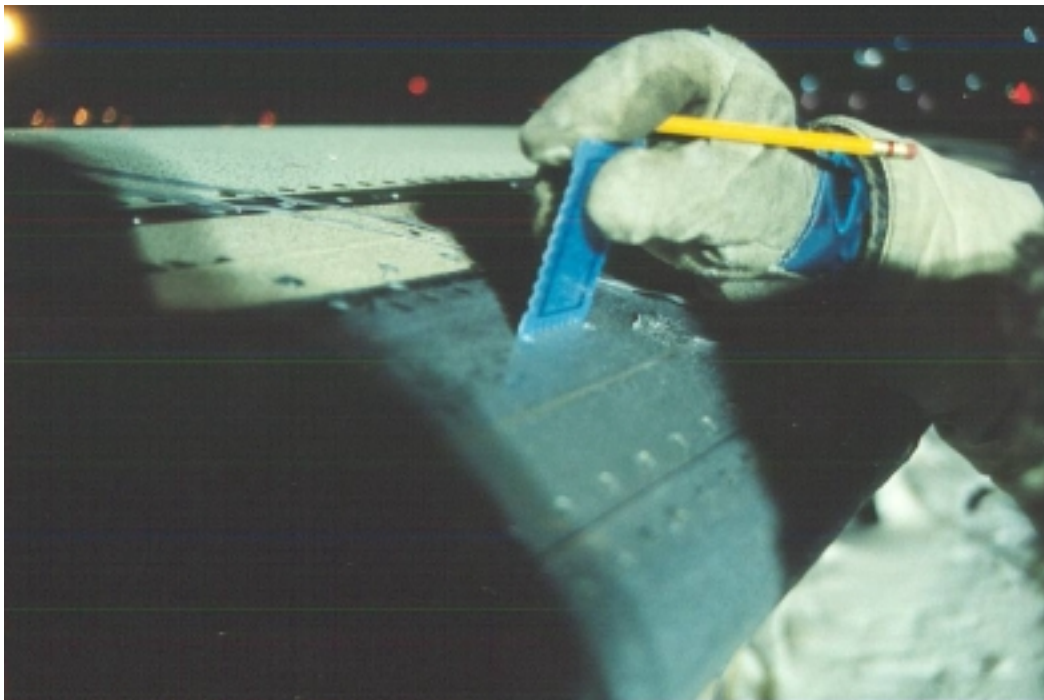

Photo 2.8
Measuring Snow Depth with Paint Gauge



3. DESCRIPTION AND PROCESSING OF DATA

Weather forecasts were monitored for suitable conditions on an ongoing basis. Several false starts were experienced when early forecasts of acceptable conditions eventually degraded and the planned test had to be cancelled. For example, on the morning of February 18, 2000, the forecast indicated 5 to 10 cm of snow overnight, with an OAT of -9°C, and winds of 10 to 15 km/h. All preparation activities to conduct the test were completed, including aircraft availability and towing arrangements, and an aircraft mechanic was enlisted to participate in the tests. All the rented equipment was reserved and ready for delivery pending final advice. AéroMag 2000 was briefed as to fluid and deicing vehicle requirements.

By mid-afternoon, the forecasted system was downgraded to only 1 to 3 cm of snow overnight, and the test session was cancelled. The eventual snowfall was recorded as only a trace.

3.1 Overview of Tests

As the winter season progressed and the likelihood of occurrence of suitable conditions decreased, it was decided to conduct a session of tests using the snowmaker. The test session was conducted overnight on March 10-11, 2000. OAT was -4 to -5°C, winds varied from 2 to 8 km/h, and there was no precipitation.

A history of the tests conducted is given in Table 3.1. Some of the columns require explanation:

- *Run #* refers to a single test during the session. The first run (1a) resulted in a very high snowfall rate and the collected data was not used. This second run was called Run 1b. Subsequent runs were numbered 2 and 3;
- *Type of Spray Application* – one or two passes differentiates between the standard method of application and a special procedure wherein the wing was resprayed after having been cleaned to get more heat into the wing skin;
- *Fluid Brix* is the initial strength of the fluid being tested. In these tests, although a dilute Type I fluid was prepared, there was only sufficient time to test with water, and so all Brix values are zero;
- *OAT* was measured at the test site with a Vaisala RH meter;
- *Snow Rate* was measured using rate pans positioned at a stand in front of the wing;

TABLE 3.1

LOG OF HOT WATER TESTS
MARCH 10-11, 2000

Run #	Type of Spray Application	Fluid Brix	OAT (°C)	Snow Rate g/dm²/h	Initial Snow Depth (cm)			Wind Speed km/h	START OF SPRAY					END OF SPRAY					Avg Fluid Nozzle Temp. (°C)	Amount of Fluid Sprayed (L)	Spray Duration	FIRST FREEZE TIME		ELAPSED TIME TO FREEZE	
									Fluid Tank Temperature		Fluid Nozzle Temp. (°C)	Fluid Meter (L)	Time	Fluid Tank Temperature		Fluid Nozzle Temp. (°C)	Fluid Meter (L)	Time				Observer		Observer	
					LE	Top	TE		(°F)	(°C)				(°F)	(°C)							MC	MH	MC	MH
1a	One pass	0	-4	124	0.3	0.2	0.2	8	150	66	N/A	0	0:57:06	130	54	55	129	1:00:00	55	129	0:02:54	1:00:00	1:00:15	0:00:00	0:00:15
1b	One pass	0	-4.6	13	<0.1	<0.1	<0.1	8	170	77	65	0	2:42:57	165	74	65	53	2:44:16	65	53	0:01:19	2:44:20	2:44:57	0:00:04	0:00:41
2	Two passes	0	-4.7	20	<0.1	<0.1	0.3	1	158	70	63	0	3:13:24	148	64	59.5	60	3:14:40	61	60	0:01:16	3:15:10	3:15:07	0:00:30	0:00:27
3	Two passes	0	-4.9	19	<0.1	<0.1	0.5	2	158	70	63	0	3:44:55	135	57	53	189	3:47:26	58	189	0:02:31	3:48:05	3:48:24	0:00:39	0:00:58

- *Initial Snow Depth* was measured on the wing leading edge (LE), top and trailing edge (TE). The intent was to start the test when snow began to accumulate on the wing surface;
- *Wind Speed* was measured before and after each test using a handheld anemometer;
- *Start of Spray* reports fluid temperature measured in the truck tank and at the nozzle, the fluid meter reading (set to zero), and the time of initial spray;
- *End of Spray* reports fluid temperature measured in the truck tank and at the nozzle, the fluid meter reading, and the time spray ended;
- *Average Fluid Temperature at the Nozzle, Amount of Fluid Sprayed, and Spray Duration* are calculated values;
- *First Freeze Time* and *Elapsed Time to Freeze* report observations by two observers each monitoring one-half of the wing; and
- *Equivalent Amount of Fluid* on a 30 X 50 cm test plate area are calculated values.

The wing observers recorded the pattern of failure and contamination thickness over the test wing. An example of a completed form is given in Figure 3.1. The locations where thickness was measured are indexed in the grid. Times of freezing are shown on the wing plan. The freezing patterns recorded by the two observers were consolidated into one sketch that is discussed in the next chapter.

The wing surface temperature data collected by the thermistor probe / data logger system was printed in chart form to show the temperature profiles for the measured locations over the test duration. Figure 3.2 provides an example of such a chart. The temperature profiles in the chart result from the type of application where the wing is first cleaned by spraying from the wingtip to the root, and then an overspray is applied from root to wingtip (to put more heat into the wing). The two temperature peaks for each measured location reflect this procedure, showing the interval between the first and second sprays.

FIGURE 3.1
ICING FORM FOR JETSTAR WING
 FIELD TESTS FOR HOT WATER DE-ICING LIMITS

DATE: 11-Mar-00

RUN #: 2

RECORDING INFORMATION:

- **At time of 1st freezing:** - Note location and time on wing form. Advise other team members
- **5 minutes after 1st freezing:** - Record patterns of ice on the wing form.
 - Measure and record ice thickness and roughness
- **Wing Cavity Inspection:** - Record appearance of any ice formation. Use additional forms as needed.

Time: 3:20:10

Ice Patches		
Location	Thickness (Mils)	Roughness
1	7	
2	9	
3	24	
4	24	
5	30	

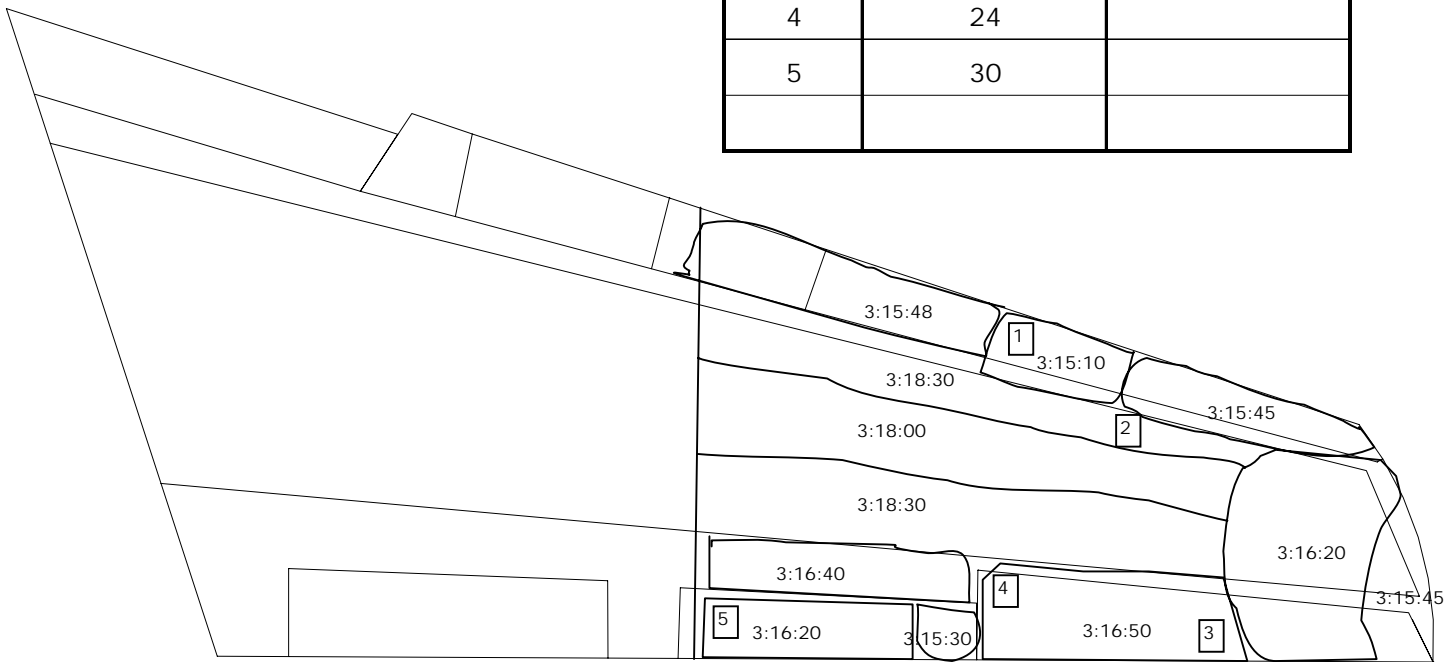

COMMENTS: _____

< 0.1 over most of the wing _____

0.3 on trailing edge _____

ICING RECORD BY: M. Chaput

HANDWRITTEN BY: M. Chaput

FIGURE 3.2
SKIN TEMPERATURE PROFILES - RUN 3
 HOT WATER TESTS - March 11, 2000

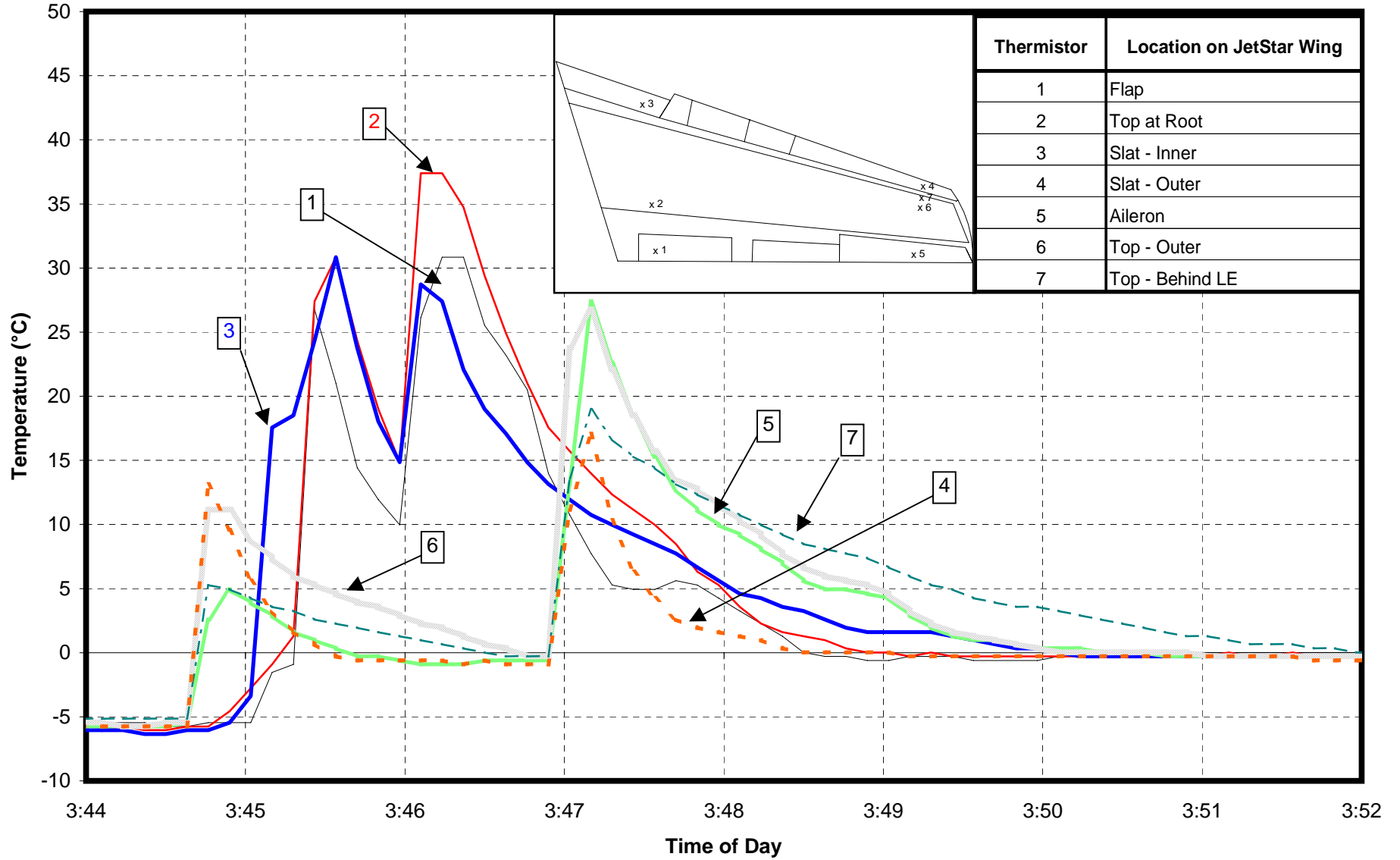

This page intentionally left blank.

4. ANALYSIS AND OBSERVATIONS

This section discusses the results of the test runs as reported in Table 3.1.

4.1 Run 1a

In this run, a very high snowfall rate (124 g/dm²/h) was experienced and, as a result, the test data were set aside. While not valid for analysis, the wing temperature profile is given in Figure 4.1. The profiles show a very rapid drop in temperature following spray application, which in combination with the extreme snowfall rate, resulted in immediate contamination.

To fix the high snowfall rate, the snowmaker was positioned farther back from the wing and the angle of elevation was raised. This decreased the quantity of snow blown directly at the wing, and also allowed the snow particles to drift down onto the wing more gently than in Run 1a. In subsequent test runs, the snowfall rate was suitable for testing and ranged from 13 to 20 g/dm²/h.

As discussed in Chapter 2, the snow was in the form of a snow pellet and was slightly wet, resulting in immediate and strong adherence to the wing skin.

4.2 Run 1b

Run 1b was a standard one-step spray application, not involving an additional spray after the wing was cleaned. The wing skin temperature profiles in Figure 4.2 show the single peaks for each measured location. The temperatures at all measured locations cooled to 0°C in about 2 minutes after spraying.

The first indication of snow appeared on the outer wing at 4 seconds following end-of-spray. This is equivalent to about 1 minute following spray application at the location where snow first appeared.

The heated water temperature at the nozzle was 65°C and 60 L of water was applied. This amount is equivalent to 318 mL on a standard test plate (dimensions 30 X 50 cm).

During the 1994-95 hot water tests, which were conducted on DC-9 wings and where the spray was applied by deicing operators

FIGURE 4.1
SKIN TEMPERATURE PROFILES - RUN 1a
 HOT WATER TESTS - March 11, 2000

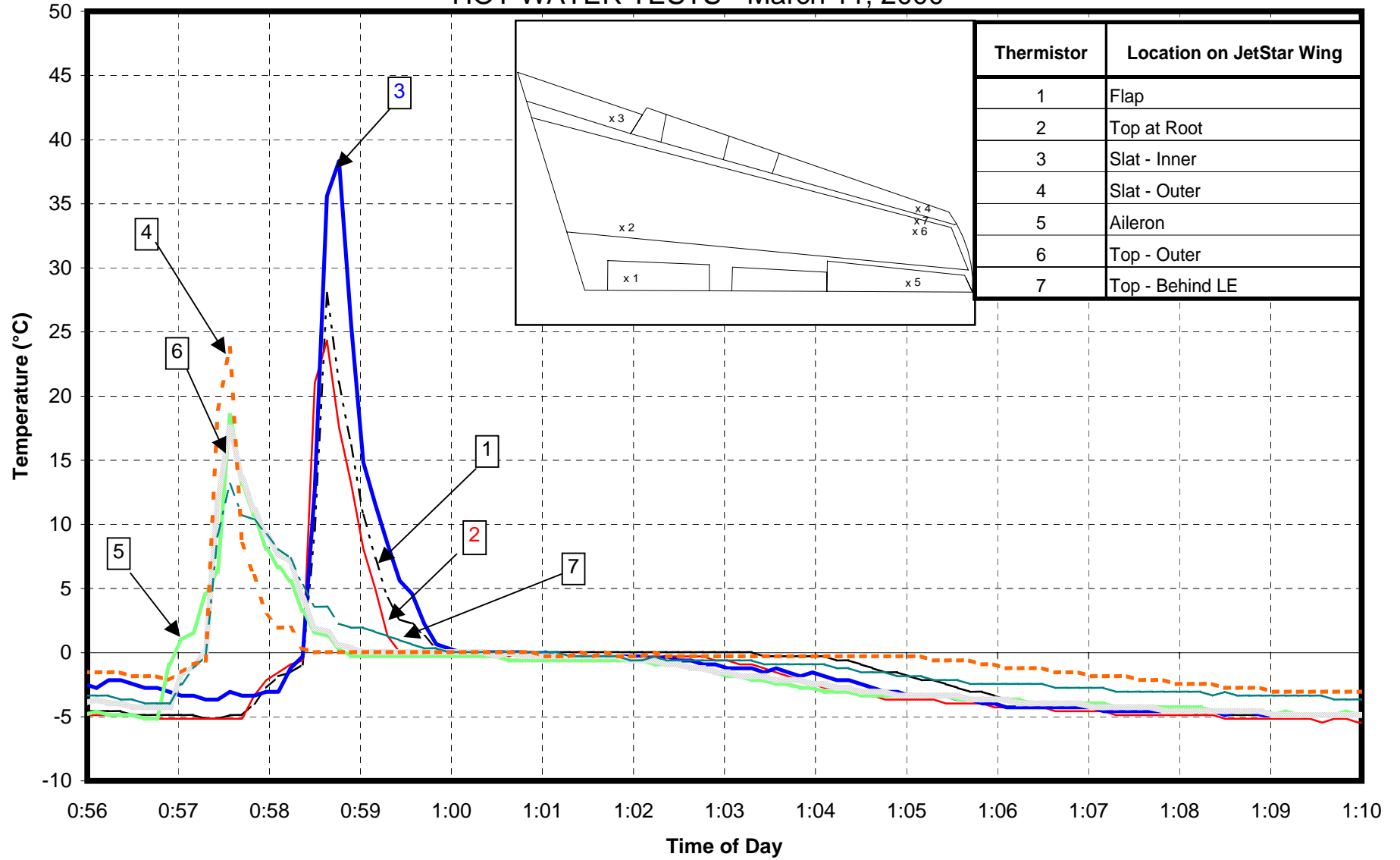
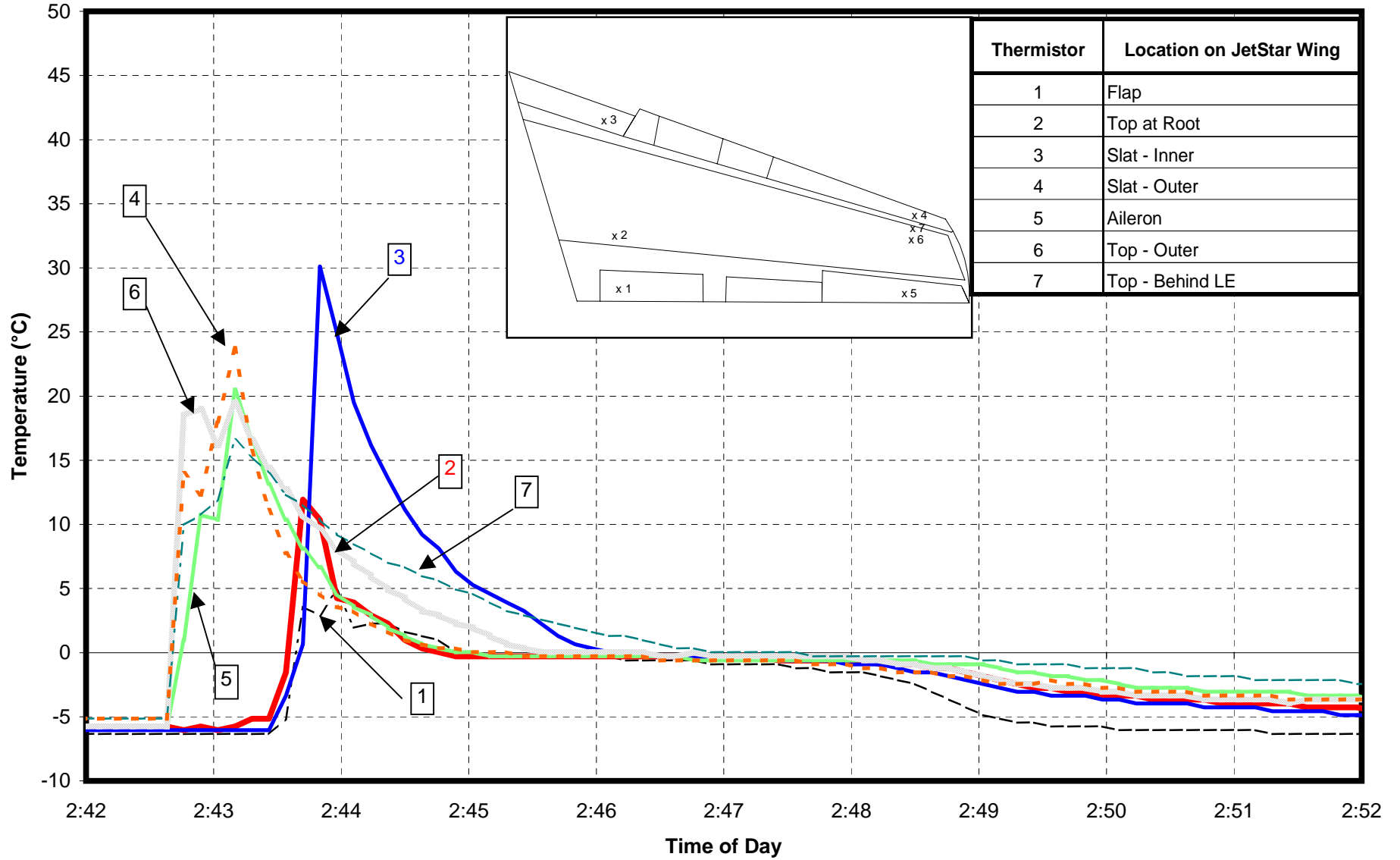

FIGURE 4.2
SKIN TEMPERATURE PROFILES - RUN 1b
 HOT WATER TESTS - March 11, 2000



experienced in the hot water deicing process, the average equivalent amount applied was 450 mL per test plate. This is 50 percent more than applied in the 1999-2000 test session. The application procedure was similar in that a single pass was conducted to clean the wing without a following overspray.

4.3 Run 2

The spray application in this test involved two passes, with an overspray of fluid from root to wingtip once the wing had been cleaned. The operator was instructed to attempt to apply about 170 L uniformly over the wing, including the overspray (equivalent to 1 L on a test plate). In fact only 60 L were applied over the entire wing (equivalent to 0.4 L per plate).

The heated water temperature at the nozzle was 61°C.

Figure 4.3 shows the wing skin temperature profiles, with the double peak reflecting the spray procedure.

At 30 seconds following end-of-spray, the first indication of snow appeared on the outer part of the wing on the leading edge slat. The interval following spray application at that area until appearance of snow was about 45 seconds. Reference to Figure 4.3 shows that the skin temperature on the outer leading edge slat reached a significantly lower peak than points on the top of the wing. It is believed that this area may not have received an adequate spray quantity.

Similarly, on the inner wing the first area of failure was a small spot near the wing root. The surrounding area lasted a full minute longer prior to collecting snow; thus it is reasoned that this spot received less spray than the surrounding areas.

Further, it is noted in Figure 4.3 that overspray on the flap failed to raise the temperature to the expected level.

In conclusion, Run 2 did not conform to the desired spray procedure and, therefore, the data is not valid.

4.4 Run 3

The spray operator was again briefed to emphasize the procedure and the need to apply a generous quantity of fluid (170 L uniformly over the

FIGURE 4.3
SKIN TEMPERATURE PROFILES - RUN 2
 HOT WATER TESTS - March 11, 2000

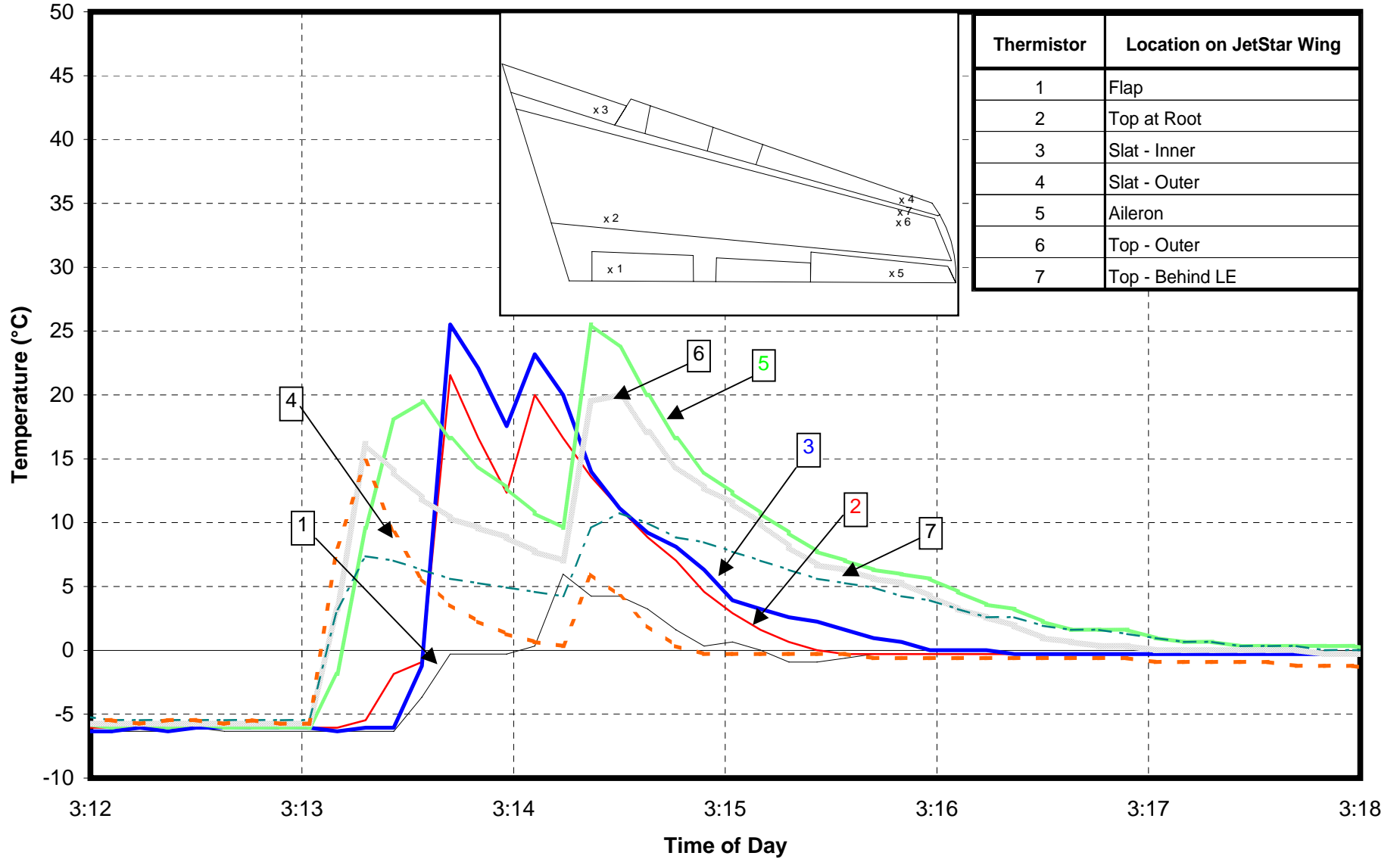

wing, including the overspray, equivalent to 1 L on a test plate).

This test went much better than Run 2, with 189 L applied (equivalent to 1.1 L on a test plate). The heated water temperature at the nozzle was 58°C (averaged over the spray duration).

Figure 4.4 shows the wing skin temperature profiles. In this case there is a noticeably longer interval between the two temperature peaks in each profile, reflecting the greater quantity of fluid applied. As well, the second peak is generally higher than the first, reflecting an adequate amount of overspray fluid applied to the cleaned wing surface.

At 39 seconds following end-of-spray, the first indication of snow on the outer part of the wing appeared, again on the leading edge slat and near thermistor probe #4. The temperature profile for that probe shows that while it reached a satisfactory peak temperature, it cooled rapidly, reaching 0°C in just over one minute.

The first area of failure on the inner wing (at 58 seconds) was also on the leading edge.

A schematic (Figure 4.5) was developed, based on observers' recorded patterns of failure, to illustrate the distribution of the pattern of freezing over the entire wing. The times shown within the sketched areas are the intervals between the time that spray was applied locally until first evidence of contamination. It is noted that the shorter times to refreeze are distributed around the perimeter of the wing, with longer periods of protection on the main part of the wing. The shortest times can be found at the very outer limit of the wing. This observation conforms to earlier field tests on various aircraft when this location was the earliest to refreeze.

The operators' spray routine may be at least a partial reason for this distribution of intervals to refreeze. When directing the spray, the natural tendency is to aim the nozzle so that the total spray pattern strikes the wing surface. This would mean that the main part of the wing away from the perimeter is always subjected to oversplash and fluid feed from its neighbouring area. This is not true at the wing edge, where any fluid oversplash comes only from one direction, that of the main wing. As a result, the edge of the wing would receive less fluid.

Regardless of the reason for the pattern, it appears that additional quantities of fluid need to be directed toward the wing perimeter in order to achieve intervals until refreeze equal to that of other areas on the wing.

FIGURE 4.4
SKIN TEMPERATURE PROFILES - RUN 3
 HOT WATER TESTS - March 11, 2000

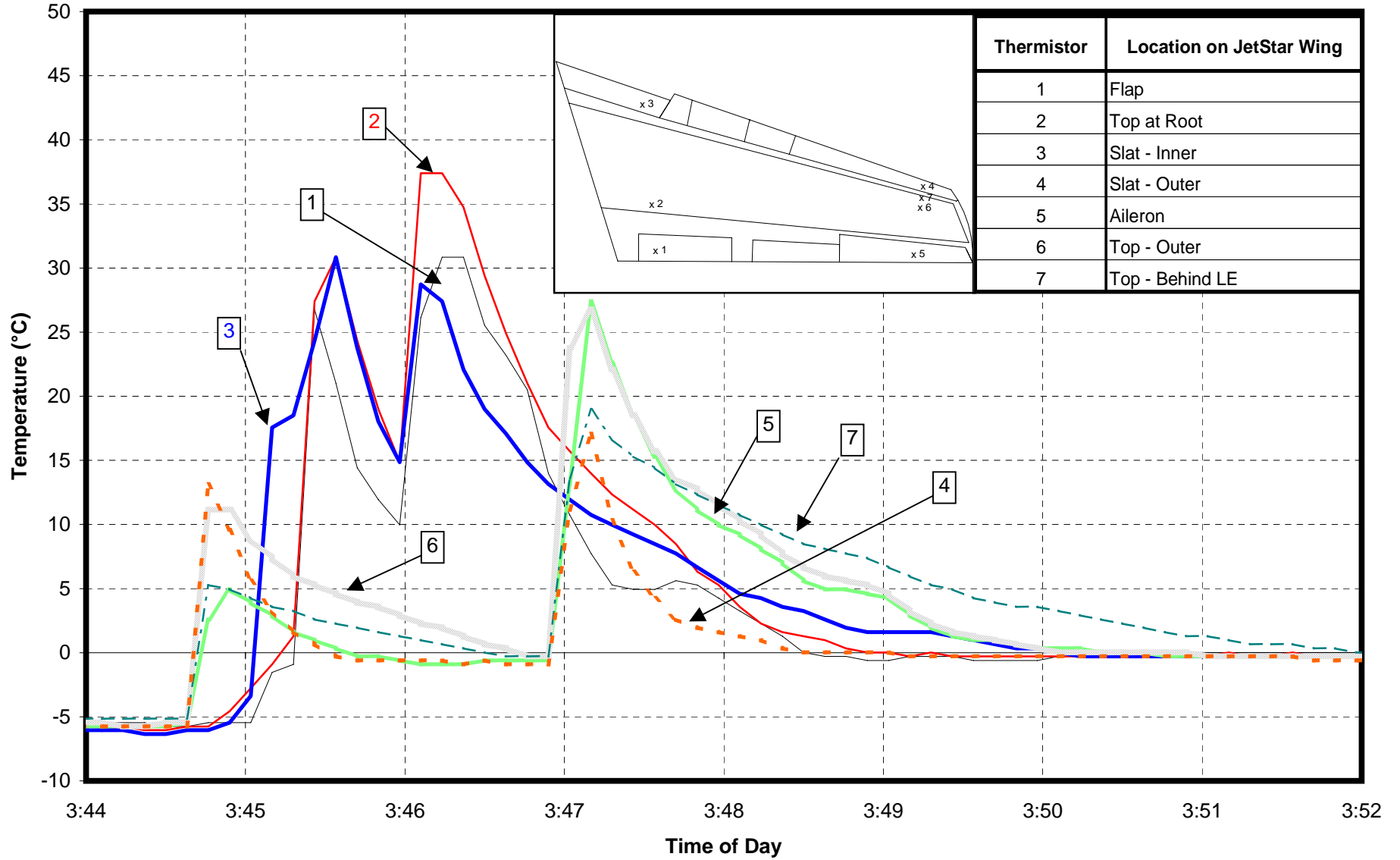
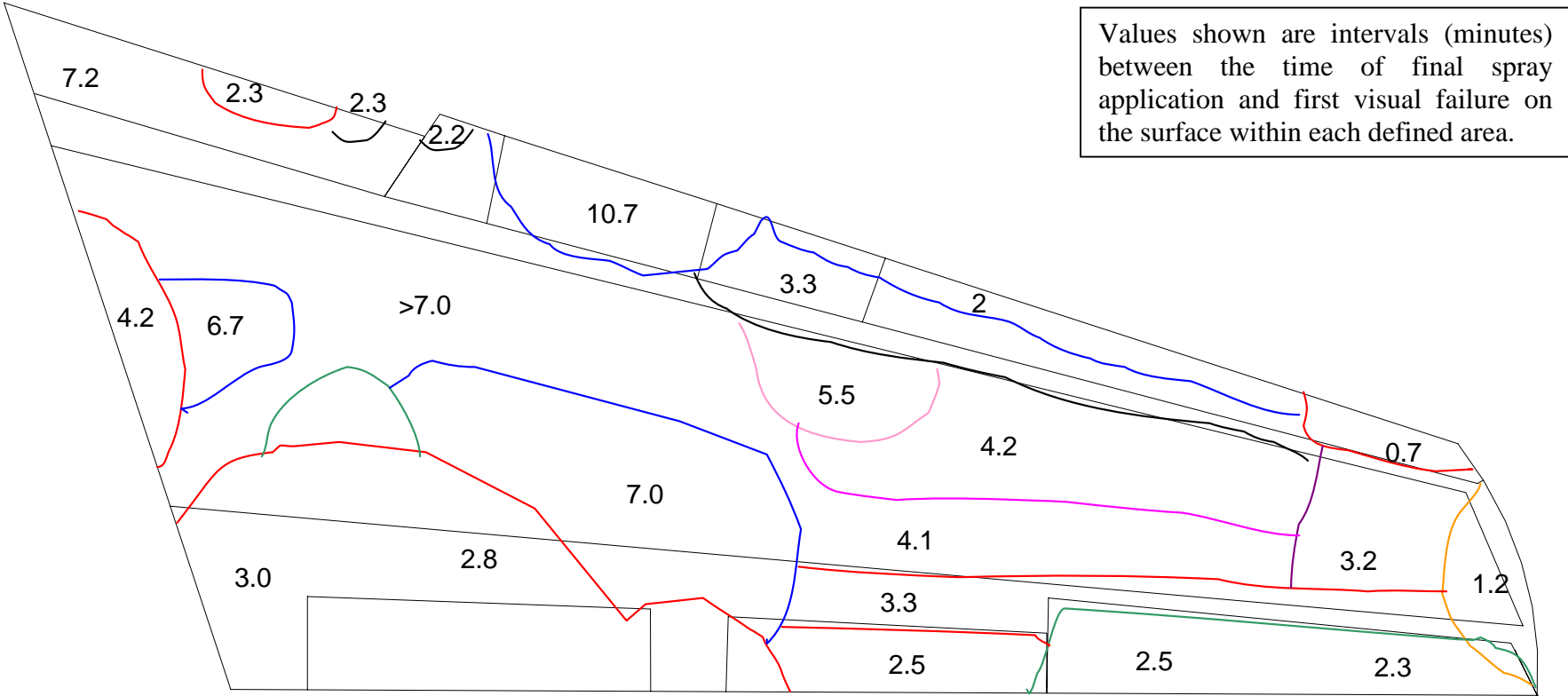

FIGURE 4.5
PATTERN OF FREEZING TIMES ON THE TEST WING – RUN 3
 HOT WATER TESTS MARCH 11, 2000 – DORVAL AIRPORT



The time until refreeze was shorter than expected for this test, even though adequate amounts of fluid were applied. One factor contributing to the shorter times was the temperature of the heated water. During this test, the nozzle temperature dropped from an initial value of 63°C to 53°C by the end of the test. This means that the temperature of the overspray (the latter part of the application) was not as hot as it should have been. With the additional temperature drop from nozzle to wing, the water temperature at the wing was probably lower than 50°C. When this point was reviewed with the operator, it was learned that the driver had controlled the tank temperature manually, by turning the burners on and off. In previous test sessions where fluid temperature control was required, the tank thermostats had been reset to desired levels prior to the test. Attention will be given to this for any future tests.

Some discussion centred on the fact that the test wing was empty of fuel. The fuel levels on the DC-9 aircraft tested in the 1994-95 Hot Water Tests (1) were about 1/4 full, less than the quantity required for the upper skin to be wetted (about 2/3 full). In those tests, much longer intervals to refreeze were recorded than seen here. In both tests, the pattern of earliest refreezing was around the perimeter of the wing. The influence of any fuel in the wing tanks on temperature of the leading edge and flight control surfaces is not well understood. Any future tests should investigate this question. Information on this subject should be used to determine the extent of fuel maintained in the JetStar test wing.

This page intentionally left blank.

5. CONCLUSIONS

Based on the observations and results of these tests, several conclusions can be drawn.

5.1 Spray Technique

The pattern of first freezing in the final test in which an adequate quantity of hot water was applied shows that special attention needs to be given to ensure an adequate amount of spray is directed at the wing edges in order to achieve desired intervals until refreeze. This is probably as true for operational deicing with FPD fluids as it is for hot water deicing.

5.2 Limits on Use of Hot Water

Insufficient data was collected to confirm laboratory results. In this first test session using a snow gun to provide snow, only one test was completed in conformance to test procedures.

5.3 Effect of Quantity of Hot Water

Results of the final test (Run 3) in which additional water was applied demonstrated a longer time to refreeze as compared to the previous test (Run 2). Further tests are needed to fully understand the beneficial effect. As well, the optimum spray pattern to transfer heat to the wing should be investigated. It may be that the nozzle setting used to clean the wing is not optimum for the second phase of the spray application when the objective is to transfer heat to the wing skin.

5.4 Test Procedures

5.4.1 Use of the Snowmaker

Although natural snow is preferred, the snow generated by this equipment is adequate for hot water tests, provided that the OAT is colder than -5°C to avoid the problem of wet snow adherence. It is expected that the snowmaker will deposit snow over a large part of any test aircraft, and will require deicing of the complete aircraft at test end.

When testing at the Dorval Airport CDF, if the fire hydrant near the fire station continues to be the source of water for snowmaking, taxiway Juliet must be closed.

5.4.2 Operator Spray Technique

It was seen in these tests that spray technique is critical to achieving desired intervals until refreeze. Particular attention will need to be given to spray operator training in any future tests.

5.4.3 Fluid Temperatures

Future tests must give close attention to fluid temperatures to ensure that test parameters are satisfied throughout the duration of testing.

5.4.4 Use of the Test Wing

The test wing is a satisfactory test surface for these tests, although supplementary tests on operational aircraft are recommended.

The influence of the lack of fuel in the wing tanks on test results is not well understood. Any future tests should give attention to investigating the influence that fuel in wing tanks has on temperature of the leading edge and other flight control surfaces. Information on this subject should be used to define the extent of fuel maintained in the JetStar test wing.

6. RECOMMENDATIONS

It is recommended that:

1. The series of tests described in the test procedure be completed during the 2000-01 winter season. This activity should examine the influence of varying quantities and temperature of hot water. Full-strength and diluted Type I fluids should be tested as reference cases.
2. The effect of different spray nozzle patterns be examined to determine the optimum procedure relative to transferring heat from the sprayed fluid to the wing skin. This examination should also address the issue of the observed lower temperatures at the wing perimeter, and determine optimum spray procedures.
3. Future tests give particular attention to:
 - training the spray operator in the desired method of spraying and
 - ensuring control of fluid temperatures to specified levels.

This page intentionally left blank.

REFERENCES

1. Dawson, P., D'Avirro, J., *Hot Water De-icing Trials for the 1994-1995 Winter*, APS Aviation Inc., Montreal, December 1995, Transportation Development Centre report, TP 12653E, 48.
2. Dawson, P., Hanna, M., Chaput, M., *Aircraft Deicing Fluid Freeze Point Buffer Requirements: Deicing Only and First Step of Two-Step Deicing* (to be published), APS Aviation Inc., Montreal, December 1998, Transportation Development Centre report, TP 13315E, 168.
3. Dawson, P., Hanna, M., Chaput, M., Peters, A., Blais, N., *Aircraft Deicing Fluid Freeze Point Buffer Requirements for Deicing Only Conditions*, APS Aviation Inc., Montreal, October 1999, Transportation Development Centre report, TP 13478E, 176.
4. Dawson, P., Hanna, M., *Hot Water Deicing of Aircraft*, APS Aviation Inc., Montreal, October 1999, Transportation Development Centre report, TP 13483E, 92.
5. Chaput, M., Hanna, M., *Preparation of JetStar Wing for Use in Deicing Research*, APS Aviation Inc., Montreal, August 2000, Transportation Development Centre report, TP 13667E, 48.

This page intentionally left blank.

APPENDIX A

**EXCERPT FROM
TRANSPORTATION DEVELOPMENT CENTRE WORK STATEMENT**

EXCERPT FROM
TRANSPORTATION DEVELOPMENT CENTRE

WORK STATEMENT

AIRCRAFT AND FLUID HOLDOVER TIME TESTS FOR WINTER 1999-2000

(December 1999)

5.10 Further Evaluation of Hot Water Deicing

The study on hot water deicing conducted during the winter season 1998/99 concluded that hot water could safely be used during ambient temperature conditions colder than now authorized. Those trials were conducted in laboratory conditions. The original experimental design included trials on aircraft to confirm laboratory findings. The field trials were not conducted due to lateness in the winter season, and are still an important element of the confirmation and acceptance process, this task aims at conducting those aircraft trials during the winter 1999/2000 season.

5.10.1 *Purpose of Trials*

The contractor shall conduct trials to provide confirmation of test results observed in laboratory conditions.

Two test sessions on aircraft are proposed: one in snow conditions and one in freezing rain or drizzle. Two further trials on the Transport Canada test wing are also proposed. Trials will examine the application of a deicing fluid mixed to the currently approved buffer level, to serve as a reference.

5.10.2 *Conduct of Trials and Assembly of Results*

Data collected in these trials will include:

- Type, quantity and temperature of fluid applied;
- Record of weather conditions and precipitation rate;
- Time and location for freezing to start to appear on wing surfaces;
- Thickness and roughness of ice formation;

- Examination of wing cavities for evidence of ice;
- Temperature history of points on the wing surface;
- Rate of dilution of deicing fluid on wing surface; and
- Photo and videotape records of test set-up and results.

The contractor shall co-ordinate all test activities, initiating tests in conjunction with NRC staff based on forecast weather and aircraft availability. The contractor shall analyze results and document findings in a final technical report and in presentation format.

APPENDIX B

EXPERIMENTAL PROGRAM

**FIELD TRIALS TO ESTABLISH WEATHER LIMITS FOR
HOT WATER DEICING**

**EXPERIMENTAL PROGRAM
FIELD TRIALS TO ESTABLISH WEATHER LIMITS FOR
HOT WATER DEICING**

Winter 1999/2000

Prepared for

Transportation Development Centre
Transport Canada

Prepared by: Peter Dawson

Reviewed by: John D'Avirro



December 22, 1999
Version 1.0

Editorial Revision
June 19, 2003
Version 1.1

EXPERIMENTAL PROGRAM FIELD TRIALS FIELD TO ESTABLISH ENVIRONMENTAL LIMITS FOR HOT WATER DEICING

Winter 1999/2000

During the 1998/99 Winter, APS conducted a series of laboratory trials to study the weather limits for hot water deicing. That study, supported by data from various related trials in previous years, indicated that the current ambient temperature limit of -3°C could be lowered. Field trials on aircraft would provide important evidence to authenticate the results of the 1998/99 laboratory trials.

APS will conduct a series of hot water deicing trials on aircraft and on the Transport Canada test wing, as an extension of hot water trials conducted in Winter 1998/99. These tests will be conducted at the central deicing facility (CDF) at Montreal International Airport, Dorval (YUL).

This document provides the detailed procedures and lists equipment required to support these trials.

1. OBJECTIVES

The objectives of the project are to:

- Extend hot water deicing tests to aircraft in natural outdoor precipitation conditions.
- Study the effect of varying the quantity of hot water.
- Correlate test results with data from 1998/99 laboratory trials.

2. BACKGROUND

The current limit for application of hot water (SAE ARP4737) as a first-step deicing fluid is -3°C . This limit is intended to ensure that the deicing operator has an interval of at least three minutes to apply the second-step anti-icing fluid before the applied water freezes.

Previous related studies include hot water deicing trials during the winter 1994/95 season, and a study during the winter 1997/98 season to determine fluid dilution limits for the deicing fluid applied during *deicing only* conditions, and for the first step fluid of a two-step deicing operation.

The 1994/95 study (TP 12653E) examined whether the OAT limitation for the application of hot water could safely be lowered beyond -3°C . That study, conducted primarily on aircraft and in dry conditions, indicated that hot water deicing is feasible at OAT below -3°C , depending on wind speed and operator disciplines. Earliest occurrence of freezing occurred on flight control surfaces at the rear of the wing, as opposed to the main wing surface. It was recommended that any further tests should consider examination of composite materials frequently used in the fabrication of these surfaces. Tests in a controlled environment laboratory confirmed the major influence that high winds exert on shortening the time until freezing initiates. Field operators experienced in hot water deicing stated that a cautious approach is necessary even at moderate temperatures during high winds.

The 1997/98 study on first-step fluids (TP 13315) examined application of Type I deicing fluids, as well as water, and determined the resultant interval until freezing initiated. Trials were conducted at a range of temperatures, under freezing rain and freezing drizzle precipitation. A test procedure for combining wind and precipitation conditions was devised, and a small number of trials at one OAT were conducted. This study examined the rate of dilution of the applied Type I fluids under the test levels of precipitation. Test results demonstrated that the heat transferred to the test surface from the heated first step fluid accounted for the major part of the safe period before start of freezing. Type I fluids experienced rapid dilution after application and extended the safe period to varying extent depending on rate of dilution.

The 1997/98 deicing-only study (TP 13315) examined the use of very dilute fluids to remove any contamination following precipitation. This study measured the rate of cooling of the test surface for different wind and OAT combinations, but in dry conditions.

The 1998/99 laboratory trials studying hot water deicing (TP 13483E) concluded that hot water could be used safely during ambient temperatures colder than now authorized. Field trials included in the test design to provide confirmation of laboratory findings were not conducted, and this winter 1999/2000 project is planned to complete the study as well as to examine the effect on elapsed time to onset of freezing of applying additional amounts of hot water following the initial cleaning of the wing.

3. TEST REQUIREMENTS

Four sessions of field trials will be conducted in precipitation to reflect actual operational deicing conditions. Two test sessions on aircraft are planned: one in

snow conditions and one in freezing rain or drizzle. Two sessions on the Transport Canada Jetstar test wing are planned, also in natural precipitation.

The trials are intended to provide corroborating data to support findings from the 1998/99 study, which recommended potential limits for use of hot water as a first step fluid as follows:

1. To -3°C with no wind restrictions,
2. To -6°C in wind up to 10 km/h.

Recommendation 1 coincides with the currently authorized temperature limit. This test procedure addresses recommendation 2, which extends the current limits.

Test conditions desired include OAT in the range of -6 to -9°C with winds from 7 to 15 km/h.

The trials will examine applications of hot water, a deicing fluid mixed to the currently approved buffer level, and full strength deicing fluid. The quantity of hot water applied will be varied to study the influence on elapsed time to onset of freezing.

Data collected in these trials will include:

- Type, quantity and temperature of fluid applied. Fluid temperature will be measured at the tank, the nozzle and at the wing surface.
- Record of weather conditions and precipitation rate.
- Time and location for freezing to start to appear on wing surfaces.
- Thickness and roughness of any ice that forms.
- Examination of wing cavities at flight control surfaces for evidence of ice.
- Temperature history of points on the wing surface.
- Rate of dilution of deicing fluid on wing surface.
- Photo and videotape records of test set-up and results.

Figure 1 provides a plan overview of the different tests. Attachment I provides a description of test procedures.

4. EQUIPMENT AND FLUIDS

1.1 Equipment

Equipment to be employed is shown in Attachment II.

Operators at Dorval Airport will be approached to participate in these trials by making overnight aircraft available. The most likely types of aircraft for testing are the McDonnell-Douglas DC-9, Boeing B737, and Canadair Regional Jet (RJ).

1.2 Fluids

Water and SAE Type I EG fluid (full strength and diluted to first step limit of 3°C above OAT) will be used. Fluids will be heated to 60°C and 70°C.

5. PERSONNEL

Eight APS staff members are required for these tests.

Services of an aircraft mechanic to extend flight control surfaces for inspection of cavities, is needed.

Aircraft deicing spraying will be provided by AéroMag 2000.

Attachment III lists task assignments.

6. DATA FORMS

Figure 1	Test Plan
Figure 2	General Form (Every Test)
Figure 3a	Brix Form for DC-9 Wing
Figure 3b	Brix Form for B737 Wing
Figure 3c	Brix Form for JetStar Wing
Figure 3d	Brix Form for RJ Wing
Figure 4a	Icing Location Form for DC-9 Wing
Figure 4b	Icing Location Form for B737 Wing
Figure 4c	Icing Location Form for JetStar Wing
Figure 4d	Icing Location Form for RJ Wing
Figure 5	Meteo / Plate Pan Data Form

FIGURE 1
TEST PLAN
FIELD TRIALS FOR HOT WATER DEICING LIMITS
 Winter 1999/2000

RUN	OAT (°C)	PRECIP. TYPE	FLUID TYPE	FLUID QTY.	FLUID TEMP. (°C)	TEST SURFACE
1	-6 TO -12	Snow	Water	As Rq'd to clean wing	60	Aircraft Wing
2	-6 TO -12	Snow	Water	As Rq'd to clean wing	70	Aircraft Wing
3	-6 TO -12	Snow	Water	Equiv to 1.0 L/plate	60	Aircraft Wing
4	-6 TO -12	Snow	Water	Equiv to 1.5 L/plate	60	Aircraft Wing
5	-6 TO -12	Snow	Dilute T1E	As Rq'd to clean wing	60	Aircraft Wing
6	-6 TO -12	Snow	Neat T1E	As Rq'd to clean wing	60	Aircraft Wing
7	-6 TO -12	Freezing Rain	Water	As Rq'd to clean wing	60	Aircraft Wing
8	-6 TO -12	Freezing Rain	Water	As Rq'd to clean wing	70	Aircraft Wing
9	-6 TO -12	Freezing Rain	Water	Equiv to 1.0 L/plate	60	Aircraft Wing
10	-6 TO -12	Freezing Rain	Water	Equiv to 1.5 L/plate	60	Aircraft Wing
11	-6 TO -12	Freezing Rain	Dilute T1E	As Rq'd to clean wing	60	Aircraft Wing
12	-6 TO -12	Freezing Rain	Neat T1E	As Rq'd to clean wing	60	Aircraft Wing
13	-6 TO -12	Snow	Water	As Rq'd to clean wing	60	Test Wing
14	-6 TO -12	Snow	Water	As Rq'd to clean wing	70	Test Wing
15	-6 TO -12	Snow	Water	Equiv to 1.0 L/plate	60	Test Wing
16	-6 TO -12	Snow	Water	Equiv to 1.5 L/plate	60	Test Wing
17	-6 TO -12	Snow	Dilute T1E	As Rq'd to clean wing	60	Test Wing
18	-6 TO -12	Snow	Neat T1E	As Rq'd to clean wing	60	Test Wing
19	-6 TO -12	Freezing Rain	Water	As Rq'd to clean wing	60	Test Wing
20	-6 TO -12	Freezing Rain	Water	As Rq'd to clean wing	70	Test Wing
21	-6 TO -12	Freezing Rain	Water	Equiv to 1.0 L/plate	60	Test Wing
22	-6 TO -12	Freezing Rain	Water	Equiv to 1.5 L/plate	60	Test Wing
23	-6 TO -12	Freezing Rain	Dilute T1E	As Rq'd to clean wing	60	Test Wing
24	-6 TO -12	Freezing Rain	Neat T1E	As Rq'd to clean wing	60	Test Wing

Note: Equivalent fluid quantities by aircraft type

Aircraft	Spray Qty.	Total Wing Area (m ²)	Liters/Wing	Gal US/Wing	Gal Br/Wing
DC-9	Equiv to 1.0 L/plate	93	310	82	68
DC-9	Equiv to 1.5 L/plate		465	123	102
B737	Equiv to 1.0 L/plate	106	353	93	78
B737	Equiv to 1.5 L/plate		530	140	117
Jetstar	Equiv to 1.0 L/plate	50	168	44	37
Jetstar	Equiv to 1.5 L/plate		252	67	55
RJ	Equiv to 1.0 L/plate	55	182	48	40
RJ	Equiv to 1.5 L/plate		273	72	60

FIGURE 2
GENERAL FORM (EVERY TEST)
 FIELD TRIALS FOR HOT WATER DE-ICING LIMITS

DATE: _____

AIRCRAFT TYPE: ATR-42 F-100 B-737 RJ DHC-8

RUN #: _____

WING: PORT (A) STARBOARD (B)

AIRLINE _____

DRAW DIRECTION OF WIND WRT WING:

FIN #: _____

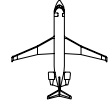

TRUCK #: _____

TYPE I FLUID NOZZLE TYPE: _____

FUEL LOAD: _____ LB / KG

FLUID APPLICATION

Actual Start Time: _____ am / pm

Actual End Time: _____ am / pm

Amount of Fluid Sprayed: _____ L / gal

Type of Fluid: _____

Fluid Temperature: Tank: _____ °C

Nozzle: _____ °C

Fluid Brix: _____

COMMENTS:

MEASUREMENTS BY: _____

HANDWRITTEN BY: _____

FIGURE 3a (1/2)
BRIX FORM FOR DC-9 WING
 FIELD TRIALS FOR HOT WATER DE-ICING LIMITS

DATE: _____

RUN #: _____

Final Drip Line Brix: _____

Snow Depth on Wing: _____

Location		Location		Location		Location		Location	
Time	Brix	Time	Brix	Time	Brix	Time	Brix	Time	Brix

Thermistor Probes Mounting Locations

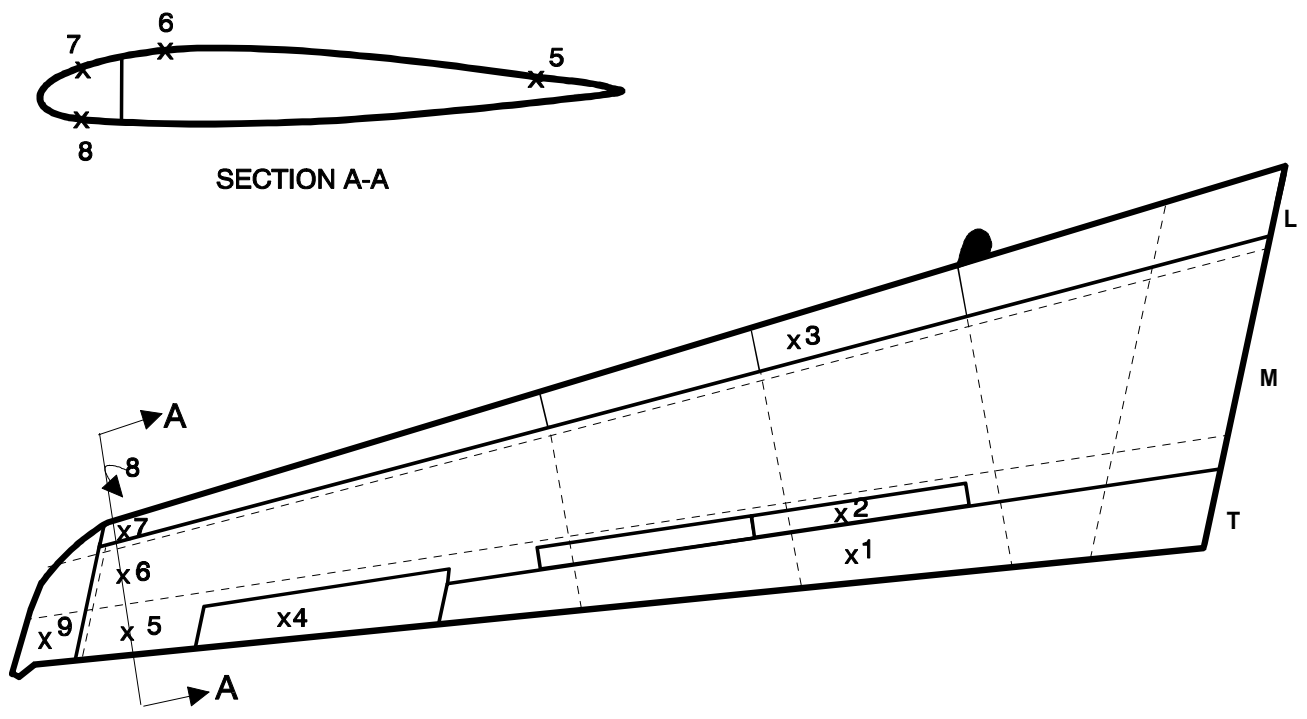

COMMENTS: _____

BRIX MEASUREMENTS BY: _____

 HANDWRITTEN BY: _____

FIGURE 3a (2/2)
BRIX FORM FOR DC-9 WING
FIELD TRIALS FOR HOT WATER DE-ICING LIMITS

Thermistor Probes Mounting Locations

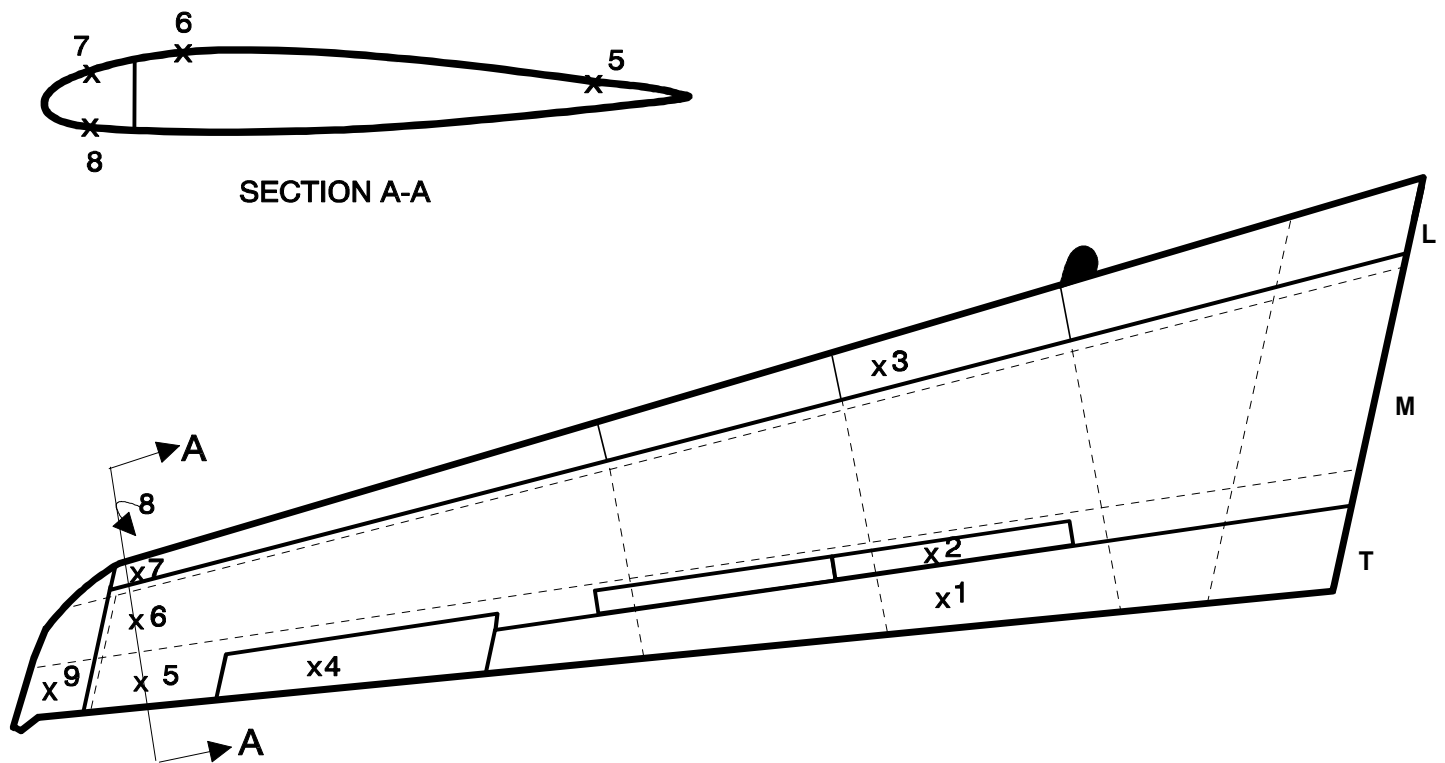

1. Mid-position on flaps, in chord with # 2
2. Mid-position on surface, chord wise and laterally
3. Mid-position on LE, in chord with # 2
4. Mid-position chord wise and laterally
5. 6" from TE, mid-way from aileron to tip
6. 6" back from LE, chord from # 5
- 7,8 Mid position on LE
9. On tip structure, 6" from TE

FIGURE 3b (1/2)
BRIX FORM FOR B737 WING
 FIELD TRIALS FOR HOT WATER DE-ICING LIMITS

DATE: _____

RUN #: _____

Final Drip Line Brix: _____

Snow Depth on Wing: _____

Location		Location		Location		Location		Location	
Time	Brix	Time	Brix	Time	Brix	Time	Brix	Time	Brix

Thermistor Probes Mounting Locations

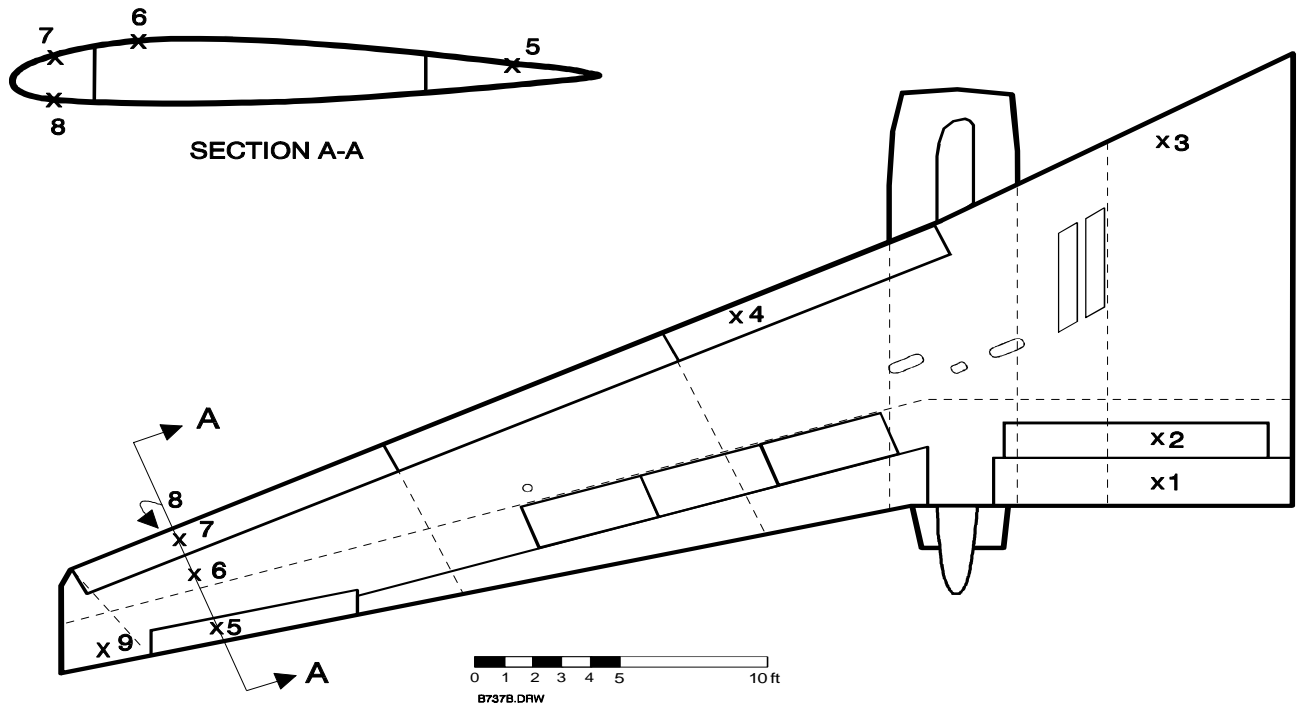

COMMENTS: _____

BRIX MEASUREMENTS BY: _____

 HANDWRITTEN BY: _____

FIGURE 3b (2/2)
BRIX FORM FOR B737 WING
FIELD TRIALS FOR HOT WATER DE-ICING LIMITS

Thermistor Probes Mounting Locations

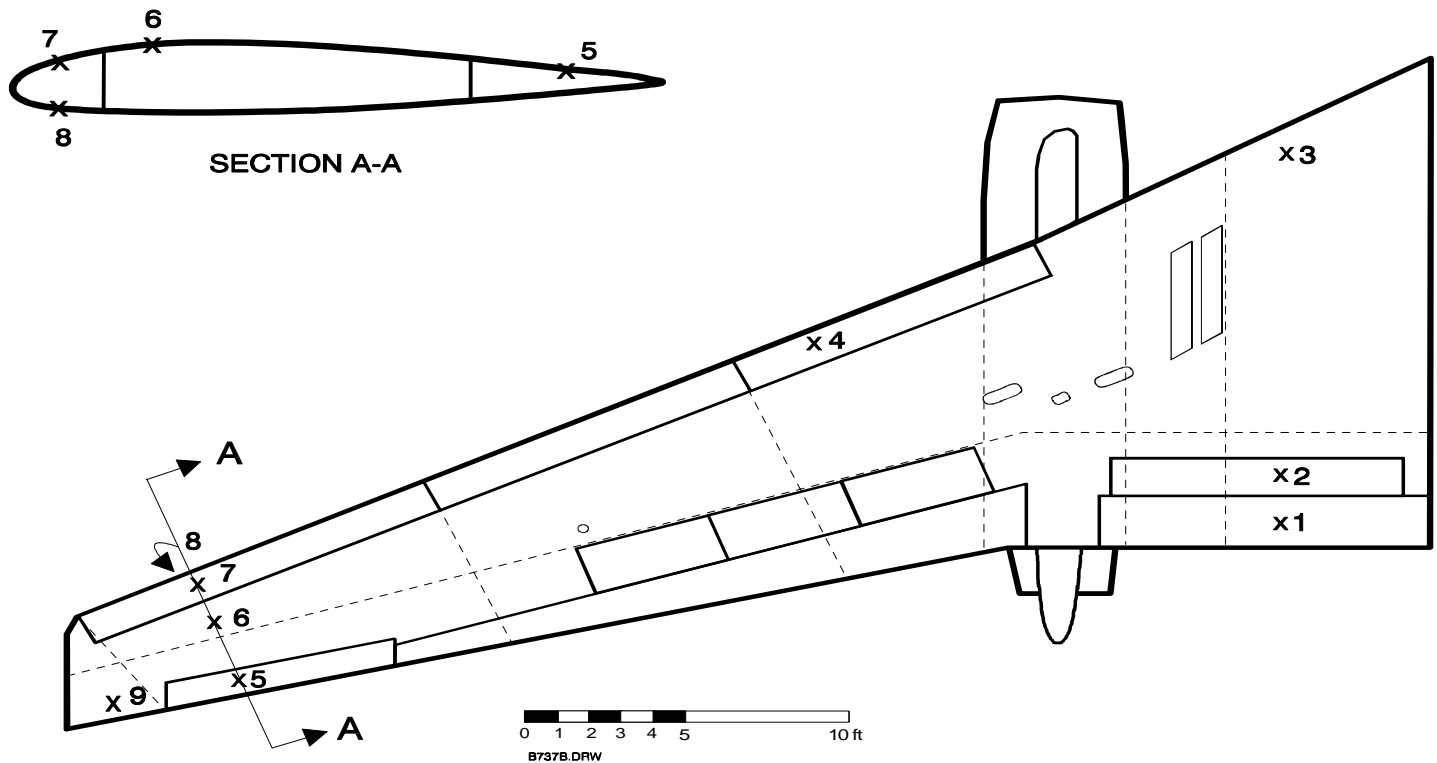

1. Mid-way on flap, chord wise and laterally
2. Mid-way chord wise with # 1
3. 6" back from LE nose
4. 6" back from LE nose, 1/3 distance along surface from outer end
5. Mid-way on surface, 1/3 distance from outer end
6. High point of wing, chord wise with # 5
- 7,8 Mid way on LE, in chord with # 5
9. 1/2 way from aileron to tip, 6" forward of TE

FIGURE 3c (1/2)
BRIX FORM FOR JETSTAR WING
 FIELD TRIALS FOR HOT WATER DE-ICING LIMITS

DATE: _____

RUN #: _____

Final Drip Line Brix: _____

Snow Depth on Wing: _____

Location		Location		Location		Location		Location	
Time	Brix	Time	Brix	Time	Brix	Time	Brix	Time	Brix

Thermistor Probes Mounting Locations

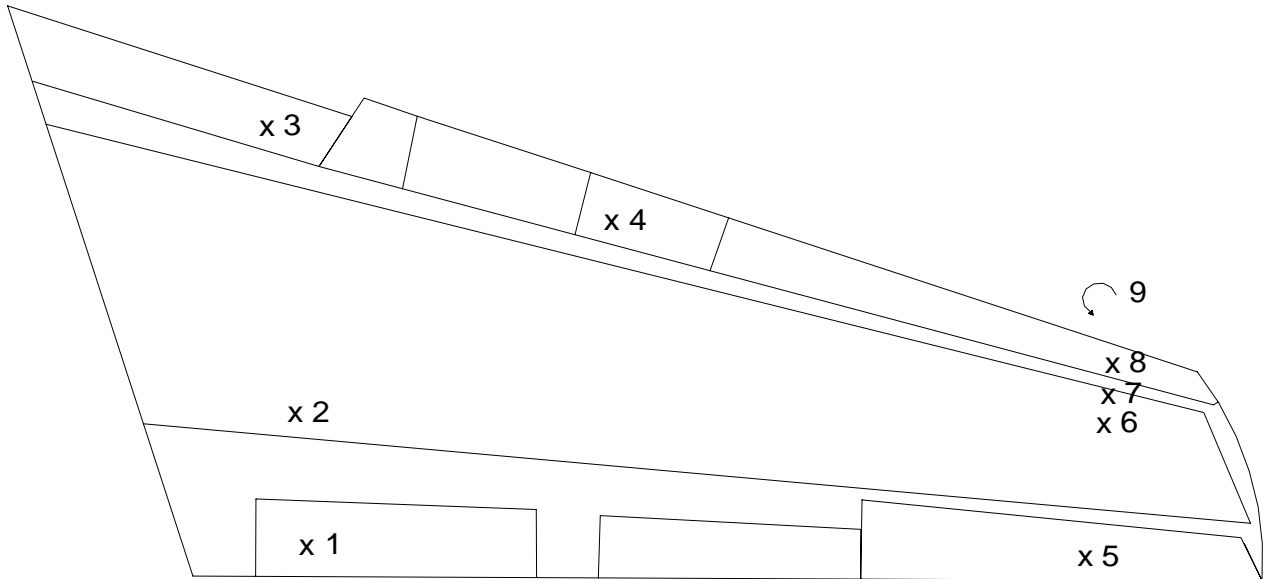

COMMENTS: _____

BRIX MEASUREMENTS BY: _____

HANDWRITTEN BY: _____

FIGURE 3c (2/2)
BRIX FORM FOR JETSTAR WING
FIELD TRIALS FOR HOT WATER DE-ICING LIMITS

Thermistor Probes Mounting Locations

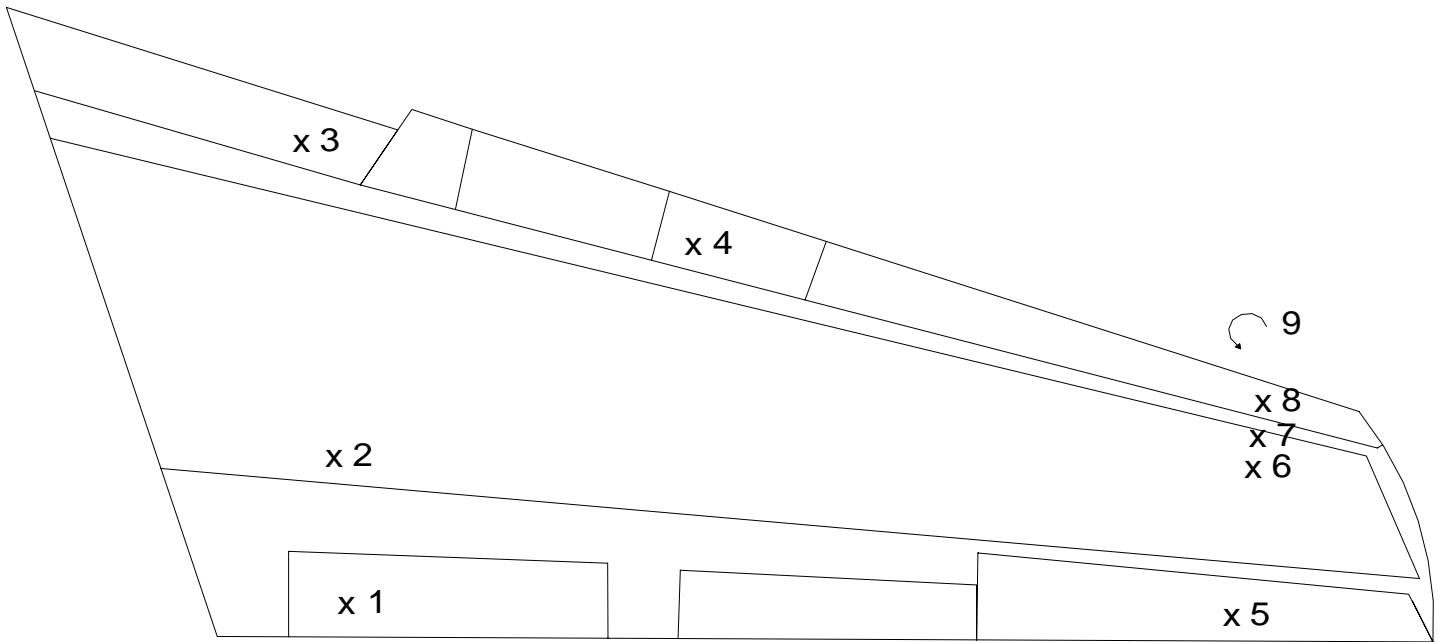

1. Mid-way forward, 1/3 distance from inner end
2. 6" forward from edge of main wing, in chord with # 1
3. Mid-way on LE, in chord with # 1
4. Mid-way chord wise and laterally on surface
5. Mid-way chordwise, 1/3 distance from outer end
6. 12" back from edge of main wing in chord with # 5
6. 6" back from edge of main wing in chord with # 5
- 8,9 1/2 way on LE, in chord with # 5

FIGURE 3d (1/2)
BRIX FORM FOR RJ WING
 FIELD TRIALS FOR HOT WATER DE-ICING LIMITS

DATE: _____

RUN #: _____

Final Drip Line Brix: _____

Snow Depth on Wing: _____

Location		Location		Location		Location		Location	
Time	Brix	Time	Brix	Time	Brix	Time	Brix	Time	Brix

Thermistor Probes Mounting Locations

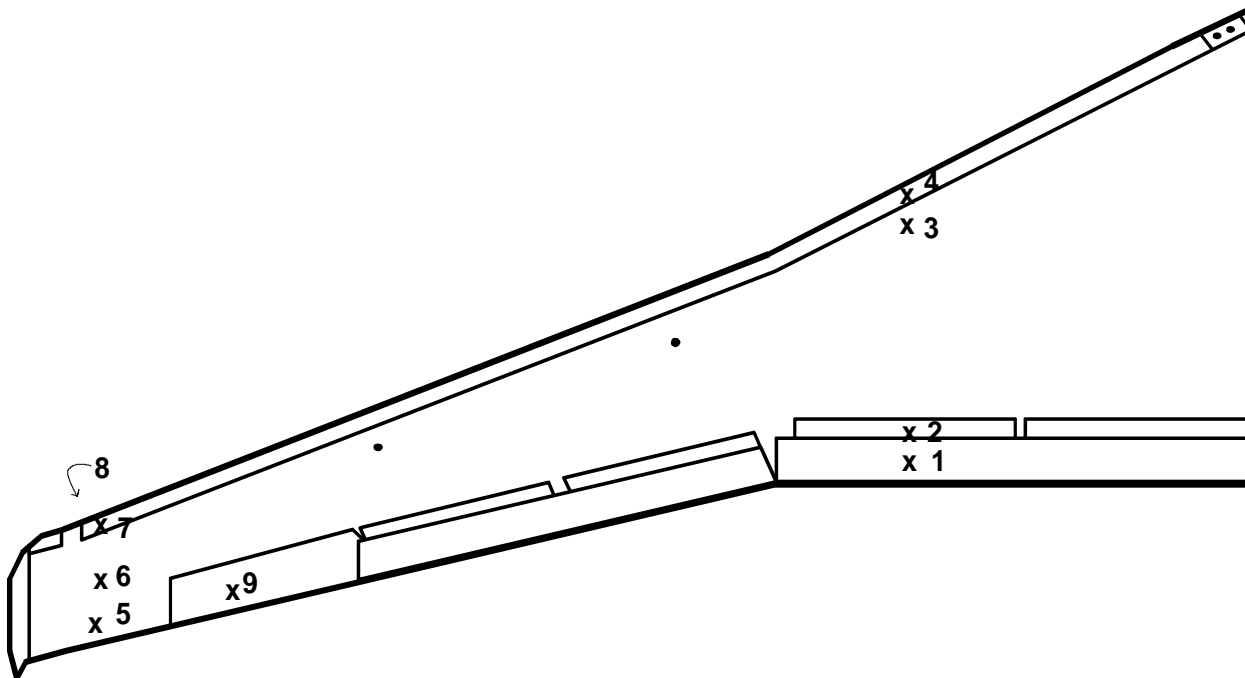

COMMENTS: _____

BRIX MEASUREMENTS BY: _____

HANDWRITTEN BY: _____

FIGURE 3d (2/2)
BRIX FORM FOR RJ WING
FIELD TRIALS FOR HOT WATER DE-ICING LIMITS

Thermistor Probes Mounting Locations

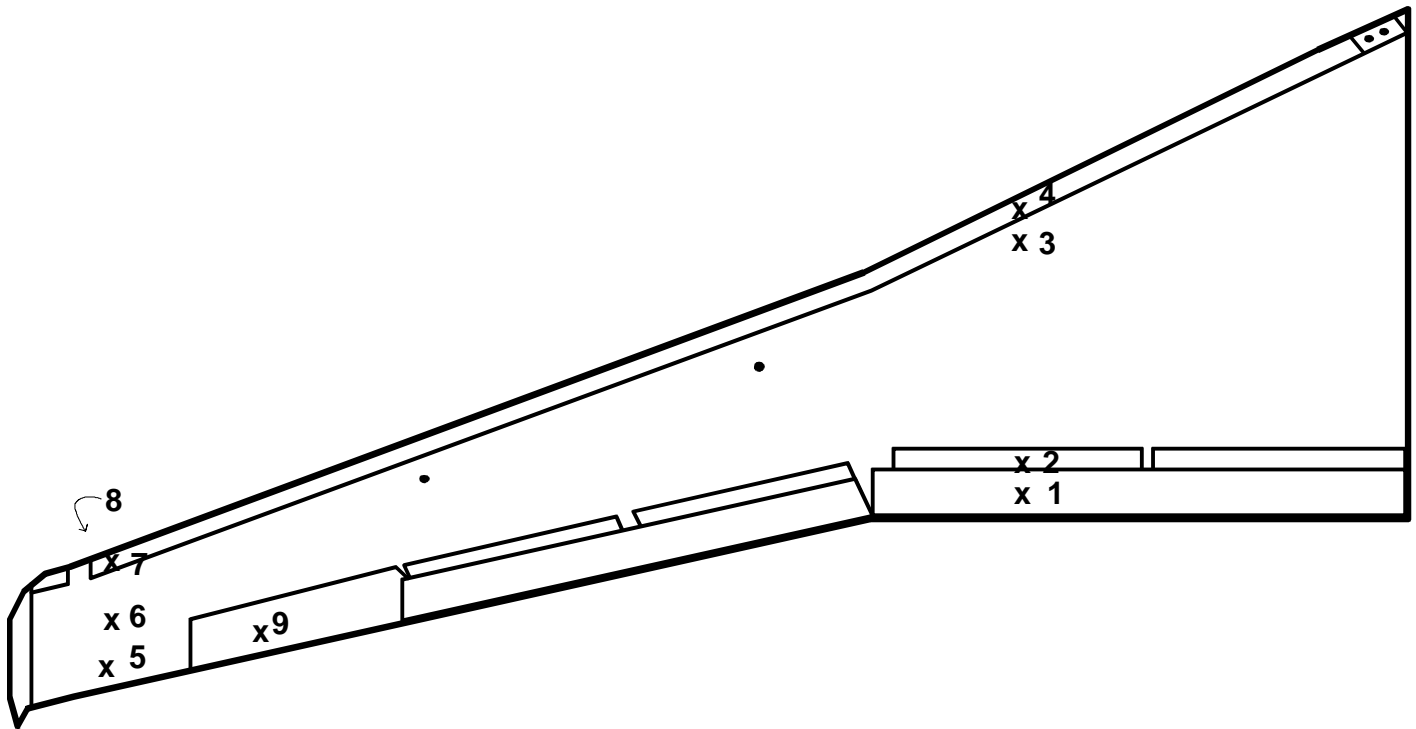

1. 1/2 way chord wise, in line with # 2
2. 1/2 way chord wise and laterally
3. 6" back from break, in line with # 2
4. 1/2 way on LE, in line with # 2
5. 1/2 way chord wise and laterally
6. 6" forward from TE, in chord with # 8
7. High point of wing, in chord with # 8
8. 1/2 way back on LE, on chord equivalent distance from outer end of aileron and LE
9. 1/2 back way on LE, in chord with # 8

FIGURE 4a
ICING FORM FOR DC-9 WING
 FIELD TRIALS FOR HOT WATER DE-ICING LIMITS

DATE: _____

RUN #: _____

RECORDING INFORMATION:

- **At time of 1st freezing:** - Note location and time on wing form. Advise other team members
- **5 minutes after 1st freezing:** - Record patterns of ice on the wing form.
 - Measure and record ice thickness and roughness
- **Wing Cavity Inspection:** - Record appearance of any ice formation. Use additional forms as needed.

Ice Patches		
Location	Thickness	Roughness

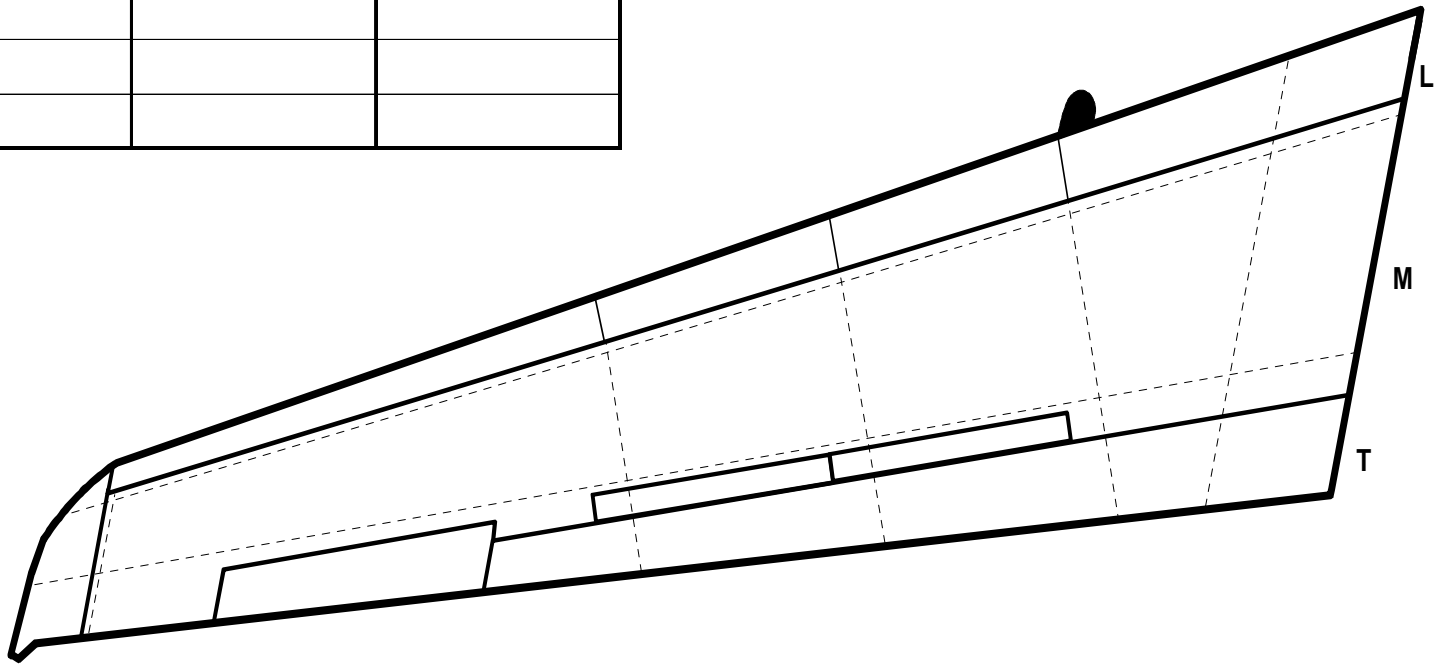

COMMENTS: _____

ICING RECORD BY: _____

 HANDWRITTEN BY: _____

FIGURE 4b
ICING FORM FOR B737 WING
 FIELD TRIALS FOR HOT WATER DE-ICING LIMITS

DATE: _____

RUN #: _____

RECORDING INFORMATION:

- **At time of 1st freezing:** - Note location and time on wing form. Advise other team members
- **5 minutes after 1st freezing:** - Record patterns of ice on the wing form.
 - Measure and record ice thickness and roughness
- **Wing Cavity Inspection:** - Record appearance of any ice formation. Use additional forms as needed.

Ice Patches		
Location	Thickness	Roughness

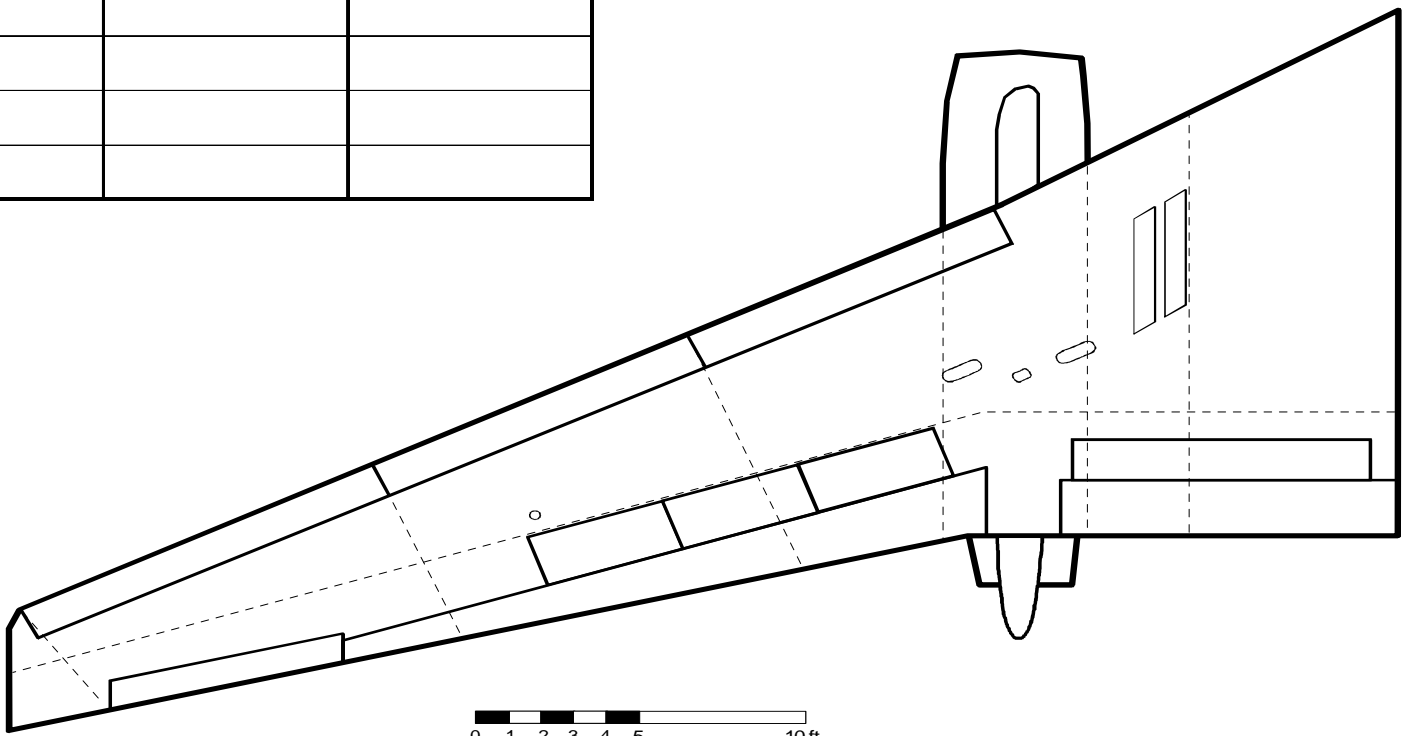

0 1 2 3 4 5 10 ft
 B737B.DRW

COMMENTS: _____

ICING RECORD BY: _____
 HANDWRITTEN BY: _____

FIGURE 4c
ICING FORM FOR JETSTAR WING
 FIELD TRIALS FOR HOT WATER DE-ICING LIMITS

DATE: _____

RUN #: _____

RECORDING INFORMATION:

- **At time of 1st freezing:** - Note location and time on wing form. Advise other team members
- **5 minutes after 1st freezing:** - Record patterns of ice on the wing form.
 - Measure and record ice thickness and roughness
- **Wing Cavity Inspection:** - Record appearance of any ice formation. Use additional forms as needed.

Ice Patches		
Location	Thickness	Roughness

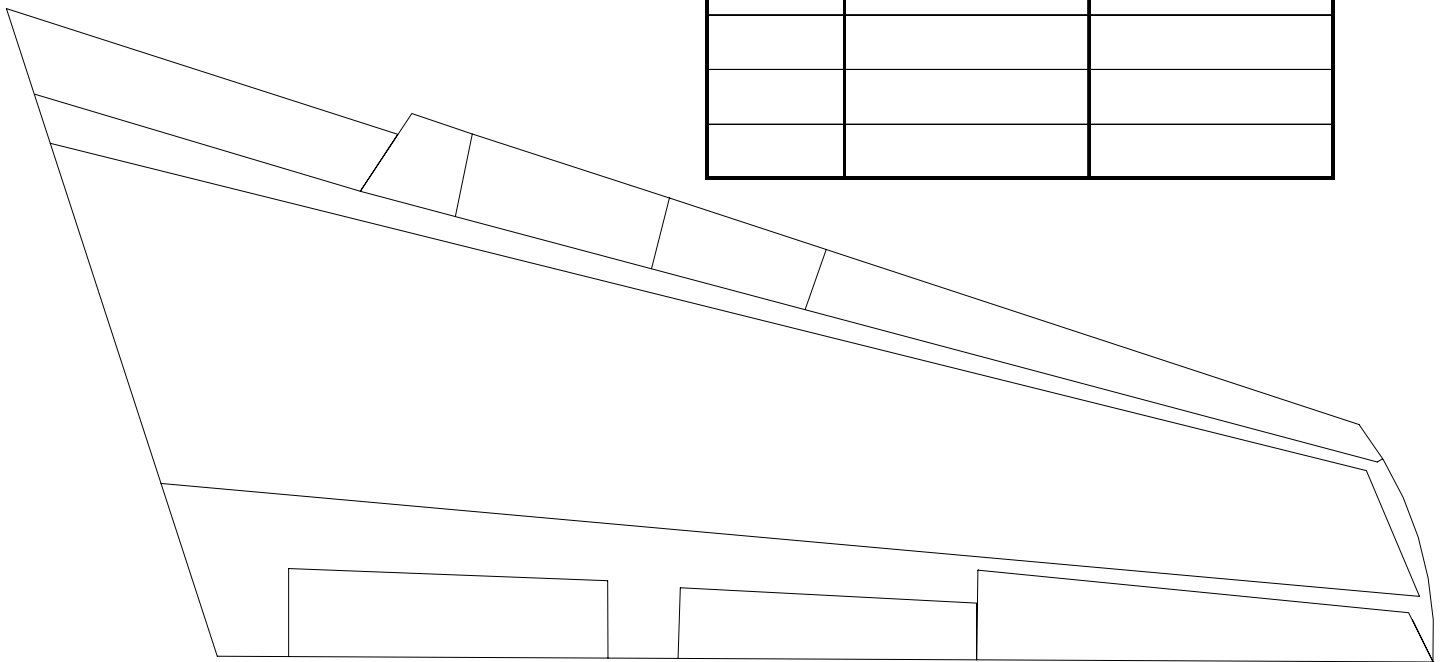

COMMENTS: _____

ICING RECORD BY: _____

HANDWRITTEN BY: _____

FIGURE 4d
ICING FORM FOR RJ WING
 FIELD TRIALS FOR HOT WATER DE-ICING LIMITS

DATE: _____

RUN #: _____

RECORDING INFORMATION:

- **At time of 1st freezing:** - Note location and time on wing form. Advise other team members
- **5 minutes after 1st freezing:** - Record patterns of ice on the wing form.
 - Measure and record ice thickness and roughness
- **Wing Cavity Inspection:** - Record appearance of any ice formation. Use additional forms as needed.

Ice Patches		
Location	Thickness	Roughness

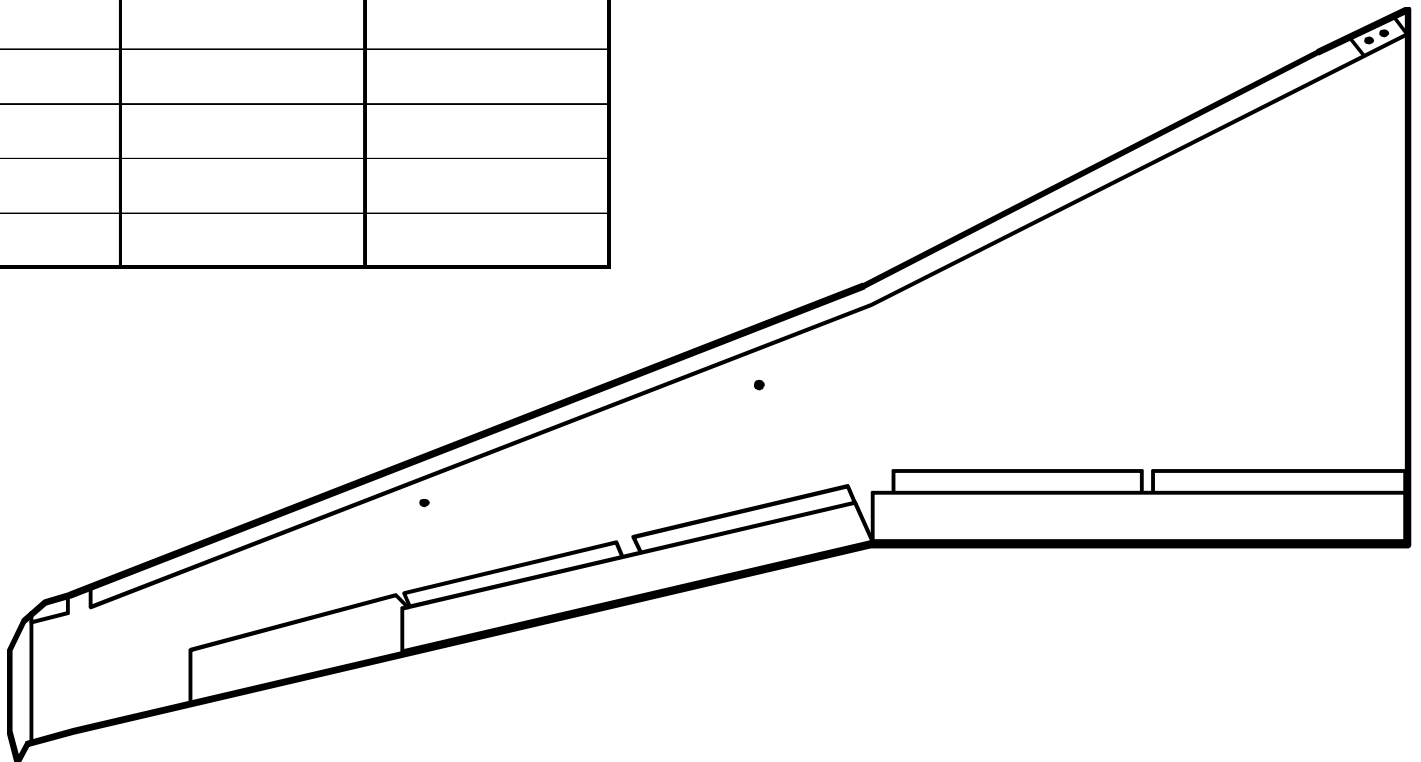

COMMENTS: _____

ICING RECORD BY: _____

 HANDWRITTEN BY: _____

TABLE 5
METEO/PLATE PAN DATA FORM
 FIELD TRIALS FOR HOT WATER DEICING LIMITS

REMEMBER TO SYNCHRONIZE TIME WITH AES - USE REAL TIME

VERSION 6.0

Winter 98/99

LOCATION: _____ DATE: _____ RUN #: _____ STAND #: _____
 HAND HELD VIDEO CASSETTE #: _____

PLATE PAN WEIGHT MEASUREMENTS *

PAN #	t TIME BEFORE (hh:mm:ss)	BUFFER TIME (Seconds)	t TIME AFTER (hh:mm:ss)	BUFFER TIME (Seconds)	w WEIGHT BEFORE (grams)	w WEIGHT AFTER (grams)	COMPUTE RATE ($\Delta w \cdot 4.7 / \Delta t$) (g/dm ² /h)

METEO OBSERVATIONS **

TIME (hr:min)	TYPE (Fig. 4) ZR, ZL, S, SG IP, IC, BS, SP	CLASSIF. (See Fig. 3)	If SNOW, WET or DRY

**observations at beginning, end, and every 10 min. intervals. Additional observations when there are significant changes.

TEMPERATURE AT START OF TEST _____ °C
 WIND SPEED AT START OF TEST _____ km/h
 WIND DIRECTION AT START OF TEST _____ °
 RELATIVE HUMIDITY _____ %

COMMENTS : _____

PRINT SIGN

WRITTEN & PERFORMED BY : _____
 VIDEO BY : _____
 TEST SITE LEADER : _____

This page intentionally left blank.

ATTACHMENT I
TEST PROCEDURES
FIELD TRIALS FOR HOT WATER DEICING LIMITS

PRE-TEST SETUP

- Brief AéroMag on procedure. Discuss fluid mix and temperature requirements.
- Empty truck and flush system. Load water and heat to 60° C for first test.
- Brief team, including aircraft mechanic, on test procedure and individual assignments. Distribute data forms.
- Park the aircraft nose into the wind.
- Set up mobile light unit. Ensure adequate illumination of wing.
- Set up generators and power cords.
- Set up stairs near the wing.
- Install thermistor probes on wing.
- Mark wing locations for Brix measurements.
- Test thermistor probes for function; set up data logger.
- Set up test-stand to support precipitation-rate measurement.
- Position cube van to support precipitation-rate measurement. Set up table, scale, lights in van.
- Ensure all cameras are functional.
- Synchronize all timepieces, loggers and cameras.

CONDUCT TESTS

The following test procedure applies both to aircraft wings and to the Jetstar test wing, with the exception that services of an aircraft mechanic are not required for the latter.

For Each Run

- Measure fluid Brix and temperature in truck tank.
- Measure fluid temperature at nozzle, spraying away from wing.
- Deice wing with test fluid. Record amount of fluid applied.
- Tests studying the effect of additional quantities of hot water will require fluid to be applied as follows. The wing will be cleaned from wingtip to fuselage, in conformance with normal procedures. The operator will then spray the specified amount of additional fluid over the cleaned wing, progressing back to the wingtip. In a field operation, application of the second-step anti-icing fluid would commence at this point.
- Record OAT, wind speed and direction and RH.

Observe Time to Freeze

- Observe wing for first freezing.

1. If freezing starts prior to 3 minutes following spray application, record time of first freezing, and location. At 3 minutes after spray application, record location and pattern of any frozen patches. Measure thickness and roughness of any ice patches.
2. If more than 3 minutes elapses following spray application until freezing starts, record time of first freezing, and location.
 - Measure fluid strength on the wing near specified probe locations (5, 6, 7, 8, 9). Take measurements immediately after fluid application and then every minute during test run and at test end. Ensure sampled locations are shifted each time to avoid repeat sampling at the same point. Protect the fluid sample from precipitation. Disregard any early freezing caused by the sampling activity.
 - Measure precipitation rate and weather conditions during test run.

Freezing in Wing Cavities

- At test end, mechanic to lower/raise flight control surfaces as necessary to allow inspection for ice formation.
- Observers and mechanic to inspect for and record any occurrence of ice in cavities. Note its characteristics (thickness or volume, consistency, adherence). Note any effect on movement of the control surface.
- Aircraft mechanic to direct the cleaning of any ice from cavities in preparation for next test.
- Mechanic to return control surfaces to normal configuration.

Prepare for Next Test

- Allow time for wing to cool to ambient temperature, and for contamination to start to form on wing surfaces.

End of Test Session

- Deice wing with deicing fluid. Mechanic to approve condition for return of aircraft to service.
- Remove thermistor probes from wing.
- Remove markings from wing.

ATTACHMENT II
TEST EQUIPMENT CHECKLIST
FIELD TRIALS FOR HOT WATER DEICING LIMITS

<i>TASK</i>	<i>STATUS</i>
Logistics For Every Test	
Monitor Forecast	
Co-ordinate with aircraft provider; arrange for a/c delivery, contact person for a/c overnight, a/c orientation, mechanic, access stair to a/c	
Co-ordinate with AéroMag; discuss truck and fluid needs	
Call personnel	
Rent cube van	
Rent mast light	
Test Equipment	
Aircraft and Access Stairs, or	
Test Wing	
<i>General for all Tests</i>	
Security passes	
Deicing truck; prepared for water spraying	
Deicing truck with normal deicing fluid	
Test procedures	
Data forms	
Wing forms	
Wind gauge	
Vaisala RH meter	
Temperature probe and spare batteries	
Clipboards	
Pencils	
Paper towels	
Electrical extension cables	
Fluid containers for truck fluid sampling	
Temperature probe for fluid at nozzle	
Tools	
Compass	
First aid kit	
Fire extinguisher	
Squeegees – long handled and regular	
Large clock	

<i>Preparing Wing</i>	
Rolling stairs X 6	
Markers, solvent and cloth wipers	
Tape measures X 4 (2 long, 2 short)	
Thermistor probes and cables	
Logger kits	
Laptop PC X 2	
Speed tape	
Heat gun	
Rubbing alcohol	
Marker	
Pylons	
Stepladder X 2	
<i>Wing Observers</i>	
Brixometers X 3	
Stop watches (alternatively use large clock if available)	
Whistle X 2	
Thickness gauges	
Flashlights to inspect cavities X 4	
<i>Precipitation Rate</i>	
Rate pans X 2	
Test stand (12 plate)	
Light for cube van	
Table	
Scale; 2 g accuracy	
Generator	
Fuel for generator	
<i>Camera Equipment</i>	
Digital video camera	
Still camera and film	
Digital still camera	

ATTACHMENT III
RESPONSIBILITIES/DUTIES OF TEST PERSONNEL
FIELD TRIALS FOR HOT WATER DEICING LIMITS

Team leader

- Initiate test with Airline, AéroMag, TDC, FAA.
- Advise APS test team
- Ensure that all required equipment is available and functional.
- Brief all involved on test procedure and assignments.
- Co-ordinate delivery of aircraft to Central Deicing Facility; advise re parking orientation.
- Ensure that all data are collected and saved, and that all test records are submitted.
- Ensure that all personnel are aware of safety issues (Attachment IV).

Photo and Video X1

- Videotape and photograph all test set-up. The record is to include location of thermistor probes on wing surface.
- Record any freezing noted by observers on wing surface or in cavities.
- Photograph and videotape wing with flight control surfaces extended.

Wing Observers X4

- Confirm assigned position with team leader.
- Working in pairs, install thermistor probes at assigned location.
- Assist in general set-up.
- Measure Brix near designated probe locations (5, 6, 7, 8, 9). Record on appropriate Brix Form.
- Observe wing condition for first freezing; record time and location using appropriate Icing Form.
- At test end, record pattern of freezing. Measure and record ice thickness and roughness.
- When control surfaces are extended, examine cavities for ice. Record location and characteristics of any ice formation. Advise mechanic and test team leader.
- Call attention of photographer to each area of ice for recording.
- Ensure all data forms completed and submitted at test end.
- Dismantle thermistor system at end of test session. Ensure no remnants of speed tape are left on wing.
- Clean any markings from wing surface with approved solvent.

Equipment Deicing Fluid Manager X 1

- Arrange rentals of required equipment.
- Prepare all equipment for moving from trailer to the CDF.
- Co-ordinate setting up major equipment at the test site.
- Before test, take sample of fluid from truck tank; measure temperature and Brix.
- Measure fluid temperature at truck nozzle just prior to each fluid application.
- Record amount of fluid applied.
- Work with AéroMag to prepare fluid in truck for next test (type, strength, temperature).
- Complete data forms and submit at end of test session.
- Oversee dismantling and orderly return of equipment.

Aircraft Mechanic

- Ensure power on aircraft for operation of flight control surfaces.
- Extend flight control surfaces when directed by test team leader.
- Assist in examining wing cavities for evidence of ice formation.
- Direct cleaning of any ice formations identified.
- Return control surfaces to normal position for next test.
- Approve wing condition at end of test session, before returning aircraft.

Precipitation Rate Observer X 1

- Set up equipment for measuring rate.
- Co-ordinate set-up of thermistor logging; ensure all probes are operating throughout test session.
- Measure precipitation rate during tests.
- Record OAT, wind speed and direction and RH.

ATTACHMENT IV
SAFETY AWARENESS ISSUES
FIELD TRIALS FOR HOT WATER DEICING LIMITS

- 1) Review MSDS sheets for fluids at site.
- 2) Protective clothing is available.
- 3) Care should be taken when climbing rolling stairs due to slipperiness.
- 4) When moving rolling stairs, ensure they do not touch aircraft.
- 5) To take fluid samples or measure film thickness on the aircraft, ensure minimum pressure is applied to the wing.
- 6) Entry into the aircraft cabin is not authorized.
- 7) When aircraft is being sprayed with fluid, testers and observers should be positioned away in the hold area.
- 8) First aid kit and fire extinguisher are available in mobile truck.
- 9) No smoking permitted on the ramp area.
- 10) Care to be taken when moving generators and fuel for the generators.
- 11) Electrical cabling is needed to power lights - these will be positioned around the wing - do not trip over them. Do not roll stairs or other equipment over cables.
- 12) Gasoline containers are needed to power the generators - ensure you know where these are.
- 13) Ensure lights and rolling stairs are stabilized so as not to damage the wing.
- 14) Ensure all objects and equipment are removed from deicing pad at end of night.
- 15) Ensure all markings removed from wing.
- 16) Personnel with escort required passes must always be accompanied by persons with permanent passes.
- 17) Rolling stairs should always be positioned such that the stairs are into the wind. Small ladders should be laid down under windy conditions.
- 18) Tests involving personnel not trained and experienced in ramp operations must take particular care to ensure safety of personnel.

This page intentionally left blank.

APPENDIX C

LENKO 950 SNOW GUN

APPENDIX C

LENKO 950 SNOW GUN

RENTAL ARRANGEMENT

The Lenko 950 Snow Gun was contracted for one week; however, because it was late in the season, the supplier agreed that the unit could be kept at the airport and used whenever conditions were suitable. MTN Snow Equipment Inc. agreed to have a technician present when the unit was used, and to relocate the unit at YMX when needed.

Charles Stenger 514 421-6324
www.mtnequipment.com

At the end of the season, because the unit had been used only once, the supplier agreed to extend the agreement into the early part of the 2000-01 winter season.

SET-UP

The snow gun requires a 600-volt power supply, 40-amp peak, 23-amp running. For the hot water tests, a 600-volt generator was rented from Hewitt.

The snow gun is equipped with a 2" male Kamlock fitting for water supply. MTN Snow Equipment lent APS an adaptor (2" female Kamlock and 2" female NPT). To enable use with the fire hydrant at the Dorval Airport Fire Station, we purchased another adaptor (2" male NPT and 2½" male QST).

Captain Cloutier at the fire station (514-633-3301) gave permission to use the fire hydrant, and also offered to lend any hose lengths that were necessary to reach the test site. Pad 5 at the Central Deicing Facility (CDF) is the closest to this water source. Note that use of this pad requires that taxiway Juliet (in front of the fire station) be closed.

For use of the snow gun at the Mirabel CDF, an alternate water supply is needed as the site is not serviced by the water system. AéroMag 2000 offered to make available their 5 000 gal water tanker. They will fill it when advised by APS and locate the tanker at the test site. It is desirable to have the water supply as cold as possible, so the filled tanker must be kept

outside. The tank can't be filled the night before tests due to the risk of freezing. MTN Snow Equipment advises that with tank water temperature of 10°C, an OAT of at least -6°C would be necessary for snowmaking. John (AéroMag mechanic 514-476-1052) reported that the tanker water outlet has a quick disconnect camlock, and confirmed that AéroMag has a range of fitting adaptors on hand.

The snow gun can be fitted with up to 5 water rings, each with 90 spray nozzles. Each ring pulls 30 gallons of water per minute. For APS tests, the snow gun is equipped with 2 water rings.

APPENDIX D
SAE AEROSPACE RECOMMENDED PRACTICE
ARP 4737
AIRCRAFT DEICING/ANTI-ICING METHODS WITH FLUIDS

Submitted for recognition as an American National Standard

AIRCRAFT DEICING/ANTI-ICING METHODS WITH FLUIDS

FOREWORD

The purpose of this document is to provide guidelines for the methods and procedures used in performing the maintenance operations and services necessary for proper deicing and anti-icing of aircraft on the ground.

Exposure to weather conditions, on the ground, that are conducive to ice formation, can cause accumulation of frost, snow, slush, or ice on aircraft surfaces and components that can adversely affect aircraft performance, stability, and control and operation of mechanical devices such as control surfaces, sensors, flaps, and landing gear. If frozen deposits are present, other than those considered in the certification process, the airworthiness of the aircraft may be invalid and no attempt should be made to fly the aircraft until it has been restored to the clean configuration.

Regulations governing aircraft operations in icing conditions shall be followed. Specific rules for aircraft are set forth in United States Federal Aviation Regulations (FAR), Joint Aviation Regulations (JAR), Canadian Air Regulations, and others. Paraphrased, these rules relate that **NO ONE SHOULD DISPATCH OR TAKE OFF AN AIRCRAFT WITH FROZEN DEPOSITS ON COMPONENTS OF THE AIRCRAFT THAT ARE CRITICAL TO SAFE FLIGHT.** A critical component is one which could adversely affect the mechanical or aerodynamic function of an aircraft. The intent of these rules is to assure that no one attempts to dispatch or operate an aircraft with frozen deposits that were not approved by the regulatory authorities.

The ultimate responsibility for the determination that the aircraft is clean and meets airworthiness requirements rests with the pilot in command of the aircraft.

SAE Technical Standards Board Rules provide that: "This report is published by SAE to advance the state of technical and engineering sciences. The use of this report is entirely voluntary, and its applicability and suitability for any particular use, including any patent infringement arising therefrom, is the sole responsibility of the user."

SAE reviews each technical report at least every five years at which time it may be reaffirmed, revised, or cancelled. SAE invites your written comments and suggestions.

Copyright 1997 Society of Automotive Engineers, Inc.
All rights reserved.

Printed in U.S.A.

QUESTIONS REGARDING THIS DOCUMENT:
TO PLACE A DOCUMENT ORDER:
SAE WEB ADDRESS:

(412) 772-8510
(412) 776-4970
<http://www.sae.org>

FAX: (412) 776-0243
FAX: (412) 776-0790

SAE ARP4737 Revision C

Outside Air Temperature OAT	One-Step Procedure see 6.3.3.1 Deicing/Anti-icing	Two-Step Procedure see 6.3.3.2	
		First Step: Deicing	Second Step: Anti-icing ¹
-3 °C (27 °F) and above	FP of heated fluid ² mixture shall be at least 10 °C (18 °F) below OAT	Water heated to 60 °C (140 °F) minimum at the nozzle or a heated mix of fluid and water.	FP of fluid mixture shall be at least 10 °C (18 °F) below actual OAT
Below -3 °C (27 °F)		FP of heated fluid mixture shall not be more than 3 °C (5 °F) above OAT	
<p>NOTE: For heated fluids, a fluid temperature not less than 60° C (140° F) at the nozzle is desirable. Upper temperature limit shall not exceed fluid and aircraft manufacturer's recommendations.</p> <p>CAUTION: Wing skin temperatures may differ and in some cases may be lower than OAT. A stronger mix (more glycol) can be used under the latter conditions.</p>			
<p>1 To be applied before first step fluid freezes, typically within 3 min. 2 Clean aircraft may be anti-iced with <i>unheated</i> fluid</p>			

FIGURE 1 - Guidelines for the Application of SAE Type I Fluid Mixtures (Minimum Concentrations) as a Function of Outside Air Temperature (OAT)

SAE ARP4737 Revision C

Outside Air Temperature OAT	One-Step Procedure see 6.3.3.1 Deicing/Anti-icing	Two-Step Procedure see 6.3.3.2	
		First Step: Deicing	Second Step: Anti-icing ¹
-3 °C (27 °F) and above	50/50 Heated ² Type II/IV	Water heated to 60 °C (140 °F) minimum at the nozzle or a heated mix of Type I, II or IV with water.	50/50 Type II/IV
Below -3 °C (27 °F) to -14 °C (7 °F)	75/25 Heated ² Type II/IV	<i>Heated suitable mix of Type I, II or IV with FP not more than 3 °C (5 °F) above actual OAT.</i>	75/25 Type II/IV
Below -14 °C (7 °F) to -25 °C (-13 °F)	100/0 Heated ² Type II/IV		100/0 Type II/IV
Below -25 °C (-13 °F)	SAE Type II/IV fluid may be used below -25 °C (-13 °F) provided that the freezing point of the fluid is at least a 7 °C (13 °F) below OAT and that aerodynamic acceptance criteria are met. Consider the use of SAE Type I when Type II/IV fluid cannot be used (see Figure 1).		
<p>NOTE: For heated fluids, a fluid temperature not less than 60° C (140° F) at the nozzle is desirable. Upper temperature limit shall not exceed fluid and aircraft manufacturer's recommendations.</p> <p>CAUTION: Wing skin temperatures may differ and in some cases may be lower than OAT. A stronger mix (<i>more glycol</i>) can be used under the latter conditions.</p>			
<p>1 To be applied before first step fluid freezes, typically within 3 min. 2 Clean aircraft may be anti-iced with <i>unheated</i> fluid</p>			
<p>CAUTION: An insufficient amount of anti-icing fluid, especially in the second step of a two step procedure may cause a substantial loss of holdover time; <i>particularly when using a Type I fluid mixture for the first step (deicing).</i></p>			

FIGURE 3 - Guidelines for the Application of SAE Type II and Type IV Fluid Mixtures (Minimum Concentrations) as a Function of Outside Air Temperature (OAT)

SAE ARP4737 Revision C

2.2 U.S. Government Publications:

Available from DODSSP, Subscription Services Desk, Building 4D, 700 Robbins Avenue, Philadelphia, PA 19111-5094.

AC 20-117 Hazards Following Ground Deicing and Ground Operations in Conditions Conducive to Aircraft Icing

3. DEFINITIONS:

3.1 Abbreviations:

C = Celsius
F = Fahrenheit
OAT = Outside Air Temperature
FP = Freezing point
h = Hours
min = Minutes

3.2 Buffer/Freezing Points:

The difference between OAT and the freezing point of the fluids used.

3.3 Fluids:

CAUTION: SAE Type I fluids supplied as concentrates for dilution with water prior to use shall not be used undiluted, unless they meet aerodynamic performance and freezing point buffer requirement (reference AMS 1424).

3.3.1 Deicing fluids are:

- a. Heated water
- b. SAE Type I (see caution)
- c. Heated concentrates or mixtures of water and SAE Type I fluid
- d. Heated concentrates or mixtures of water and SAE Type II fluid
- e. Heated concentrates or mixtures of water and SAE Type III fluid
- f. Heated concentrates or mixtures of water and SAE Type IV fluid

Deicing fluid is normally applied heated to assure maximum deicing efficiency.