

**Systems to Indicate the Position of a Hand-Operated
Switch on Non-Signalled Rail Lines**

Prepared for
Transportation Development Centre
Transport Canada

by
University of New Brunswick
Transportation Group

November 2001



**Systems to Indicate the Position of a Hand-Operated
Switch on Non-Signalled Rail Lines**

by
Frank R. Wilson
University of New Brunswick
Transportation Group

November 2001



NOTICES

This report reflects the views of the authors and not necessarily those of the Transportation Development Centre or the Steering Committee.

The Transportation Development Centre does not endorse products or manufacturers. Trade or manufacturers' names appear in this report only because they are essential to its objectives.

Since some of the accepted measures in the industry are imperial, metric measures are not always used in this report.

Research Contract Team

Coordinator: Frank R. Wilson (University of New Brunswick, Transportation Group)
Research Officers: Alemayehu Ambo (University of New Brunswick, Transportation Group)
Lino O. García (University of New Brunswick, Transportation Group)

Steering Committee

Peter Birtwistle (Transport Canada, Rail Safety Directorate)
Monique Blais (Transport Canada, Quebec Region, Surface)
Dennis Hutton (Transport Canada, Rail Safety Directorate)
R.B. Kroeker (Canadian National Railway)
Daniel Lafontaine (Transport Canada, Rail Safety Directorate)
Anthony Napoli (Consultant, Transportation Development Centre)
Michel Paquette (Transport Canada, Quebec Region, Surface)
Roger Savaria (Transport Canada, Quebec Region, Surface)
Sesto Vespa (Transport Canada, Transportation Development Centre)

Ce document est également disponible en français : «Systèmes d'indication de la position d'aiguilles à manoeuvre manuelle en zone exempte de signalisation», TP 13853F.



| | | | | | | |
|--|--|---|--|--|--|--|
| 1. Transport Canada Publication No. TP 13853E | | 2. Project No. 5013 | | 3. Recipient's Catalogue No. | | |
| 4. Title and Subtitle Systems to Indicate the Position of a Hand-Operated Switch on Non-Signalled Rail Lines | | | | 5. Publication Date November 2001 | | |
| | | | | 6. Performing Organization Document No. | | |
| 7. Author(s) F. Wilson, A. Ambo and L. García | | | | 8. Transport Canada File No. ZCD2450-D-733 | | |
| 9. Performing Organization Name and Address Transportation Group University of New Brunswick, Department of Civil Engineering P.O. Box 4400 Fredericton, New Brunswick Canada E3B 5A3 | | | | 10. PWGSC File No. MTB-0-02030 | | |
| | | | | 11. PWGSC or Transport Canada Contract No. T8200-000548/001/MTB | | |
| 12. Sponsoring Agency Name and Address Transportation Development Centre (TDC) 800 René Lévesque Blvd. West Suite 600 Montreal, Quebec H3B 1X9 | | | | 13. Type of Publication and Period Covered Final | | |
| | | | | 14. Project Officer Sesto Vespa | | |
| 15. Supplementary Notes (Funding programs, titles of related publications, etc.) | | | | | | |
| 16. Abstract <p>This report presents available technologies with potential application to indication of hand-operated switch position on non-signalled rail lines. The components and operation of each technology are described, and the acquisition cost, as indicated by the manufacturer, is estimated. It includes a benefit-cost analysis assessing the savings from reduction in property damage, personal injuries, and fatalities on main-track rail lines due to the installation of an advance warning system to advise train crews on the position of a hand-operated switch on non-signalled rail lines. Passenger travel time and cargo time savings are included in the benefit-cost analysis.</p> <p>Results show that the replacement of hand-operated switches with electrical devices does not yield a positive benefit-cost ratio if only savings in property damages and human fatalities are considered. However, if the reduction in travel time is included, the project would be economically viable. The study indicated that a number of off-the-shelf technologies are available and could feasibly be implemented.</p> | | | | | | |
| 17. Key Words Rail accidents, hand-operated switches, non-signalled rail lines | | | | 18. Distribution Statement Limited number of copies available from the Transportation Development Centre | | |
| 19. Security Classification (of this publication) Unclassified | | 20. Security Classification (of this page) Unclassified | | 21. Declassification (date) — | 22. No. of Pages x, 34, apps | 23. Price Shipping/ Handling |



| | | | | | |
|---|--|---|---|---|---|
| 1. N° de la publication de Transports Canada TP 13853E | | 2. N° de l'étude 5013 | | 3. N° de catalogue du destinataire | |
| 4. Titre et sous-titre Systems to Indicate the Position of a Hand-Operated Switch on Non-Signalled Rail Lines | | | | 5. Date de la publication Novembre 2001 | |
| | | | | 6. N° de document de l'organisme exécutant | |
| 7. Auteur(s) F. Wilson, A. Ambo et L. García | | | | 8. N° de dossier - Transports Canada ZCD2450-D-733 | |
| 9. Nom et adresse de l'organisme exécutant Groupe des transports Université du Nouveau-Brunswick, Département de génie civil Boîte postale 4400 Fredericton, Nouveau-Brunswick Canada E3B 5A3 | | | | 10. N° de dossier - TPSGC MTB-0-02030 | |
| | | | | 11. N° de contrat - TPSGC ou Transports Canada T8200-000548/001/MTB | |
| 12. Nom et adresse de l'organisme parrain Centre de développement des transports (CDT) 800, boul. René-Lévesque Ouest Bureau 600 Montréal (Québec) H3B 1X9 | | | | 13. Genre de publication et période visée Final | |
| | | | | 14. Agent de projet Sesto Vespa | |
| 15. Remarques additionnelles (programmes de financement, titres de publications connexes, etc.) | | | | | |
| 16. Résumé <p>Ce rapport présente les technologies existantes qui pourraient trouver une application dans l'indication de la position d'aiguilles à manœuvre manuelle en zone exempte de signalisation. Il décrit les composants et le principe de fonctionnement de chaque technologie et donne un aperçu des coûts d'achat, tels que communiqués par les fabricants. Il comprend en outre une analyse coûts-avantages qui établit les économies à attendre aux chapitres de la diminution des dommages matériels et du nombre de morts et de blessés découlant d'accidents en voie principale, si on installait un système capable d'avertir à l'avance les équipes des trains de la position d'une aiguille à manœuvre manuelle en zone exempte de signalisation. L'analyse tient également compte des gains de temps de déplacement des voyageurs et des marchandises.</p> <p>Selon les résultats de cette analyse, les avantages reliés au remplacement de systèmes manuels d'indication de position d'aiguilles par des dispositifs électriques ne compenseraient pas les coûts d'un tel projet, si on ne tenait compte que des économies réalisées aux chapitres des dommages matériels et des pertes de vie. Mais si l'on prend en considération la valeur du temps de déplacement, le projet devient économiquement viable. L'étude a révélé l'existence sur le marché d'un certain nombre de technologies qu'il serait possible de mettre en œuvre pour les fins envisagées.</p> | | | | | |
| 17. Mots clés Accident ferroviaire, aiguille à manœuvre manuelle, zone exempte de signalisation | | | 18. Diffusion Le Centre de développement des transports dispose d'un nombre limité d'exemplaires. | | |
| 19. Classification de sécurité (de cette publication) Non classifiée | | 20. Classification de sécurité (de cette page) Non classifiée | | 21. Déclassification (date) — | 22. Nombre de pages x, 34, ann. |
| | | | | | 23. Prix Port et manutention |

EXECUTIVE SUMMARY

The Transportation Development Centre (TDC), on behalf of Transport Canada Rail Safety, retained the Transportation Group at the University of New Brunswick to conduct a study to identify the existence and availability of technologies capable of providing advance information to train crews on the position of hand-operated switches on non-signalled rail lines. The study was designed to conduct a technical and scientific review of technologies using surveys directed to universities, research and/or development centres and suppliers/manufacturers of signalling equipment. The surveys were directed to institutions and firms in Canada, the United States, Europe and Australia. In addition, visits and interviews were held with representatives of Transport Canada, the Railway Association of Canada, Canadian National Railway, Canadian Pacific Railway, the Brotherhood of Locomotive Engineers and selected companies and institutions.

The study results indicated that cost-effective and reliable systems could be installed to indicate the position of hand-operated switches on non-signalled rail lines. Ten technologies that appeared to have potential for application to the study objective were identified. They ranged from a prototype under test by Canadian National Railway to individual components that could be assembled to construct a system. Of these, five were considered to have the highest probability of successful application.

Discussions with experts and railway operators indicate that they believe that sufficient technological means exist to develop suitable products and/or to implement existing technologies. The most important technical issues are that the system implemented should provide a high level of reliability at the lowest cost, combined with ease of installation and operation, minimal maintenance requirements and extended durability. It should also be easily upgraded to meet other requirements that may be imposed by future developments in the railway industry.

A preliminary benefit-cost analysis was undertaken to provide a ballpark estimate based on available data, which was in some cases limited. Benefits were considered to stem from savings related to reduced property damage, personal injuries, fatal accidents, and running times. It indicates that a project to replace current hand-operated switch position indicators with electronic equipment would be expensive and not justifiable, if only savings in property damage and human injuries and fatalities are considered. However, the project should be economically viable even when only 5 or 10 percent of the value of travel time for passenger and cargo operations is included in the analysis.

TABLE OF CONTENTS

| | |
|---|-----------|
| GLOSSARY | <i>ix</i> |
| 1 GENERAL | 1 |
| 1.1 Introduction | 1 |
| 1.2 Background | 1 |
| 1.3 Objective and Scope..... | 4 |
| 2 METHODOLOGY AND SURVEY DESIGN | 4 |
| 2.1 Literature Review | 5 |
| 2.2 Data Sources..... | 6 |
| 2.2.1 <i>Inventory of Suppliers and Manufacturers</i> | 6 |
| 2.2.2 <i>Inventory of Carriers</i> | 6 |
| 2.2.3 <i>Inventory of Universities</i> | 7 |
| 2.3 Interviews and Visits..... | 7 |
| 3 ANALYSIS OF MATERIAL REVIEWED | 7 |
| 3.1 Discussion of Relevant Materials..... | 7 |
| 3.2 Identification of Technologies with Potential Application | 20 |
| 4 SUMMARY OF FINDINGS AND RESULTS | 25 |
| 4.1 Reliability of Identified Technologies..... | 25 |
| 4.2 Estimation of Demand..... | 25 |
| 4.3 Acquisition and Implementation Costs | 26 |
| 4.4 Benefits..... | 26 |
| 4.4.1 <i>Savings from Reduced Property Damage, Personal Injuries and Fatalities</i> | 27 |
| 4.4.2 <i>Passenger Travel Time and Cargo Transport Time Savings</i> | 27 |
| 4.5 Estimation of Accidents | 28 |
| 4.6 Benefit-Cost Analysis | 30 |
| 5 CONCLUSIONS | 33 |
| REFERENCES | 34 |

APPENDICES

- A Survey Questionnaires
- B List of Universities, University/Industry Liaison Offices, Suppliers, Carriers, Railway Institutions and Research Centres Contacted in North America, Europe and Australia
- C Technical Material Obtained from the Literature Review

LIST OF FIGURES

| | | |
|---|------------------------------------|----|
| 1 | Autonomous Beacon System | 11 |
| 2 | Low Voltage UPS Power Supply | 12 |
| 3 | Carmanah Light Model 209 | 13 |
| 4 | Carmanah Light Model 509 | 13 |

LIST OF TABLES

| | | |
|---|---|----|
| 1 | Major Sources for Literature Review | 6 |
| 2 | CIMAT Power Systems Solar Panels Price List | 12 |
| 3 | Price List Depending on Order Size..... | 13 |
| 4 | Technologies with Potential for Application to Hand-Operated Switch Position Identification | 21 |
| 5 | Number of Rail Incidents and Accidents on Main Tracks Due to Reversed Positions of Hand-Operated Switches | 29 |
| 6 | Projected Number of Railway Incidents and Accidents Due to Reversed Positions of Hand-Operated Switches (main track only)..... | 30 |
| 7 | Results of Benefit-Cost Analysis Without Value of Travel Time | 31 |
| 8 | Results of Benefit-Cost Analysis With Value of Travel Time..... | 32 |
| 9 | Results of Sensitivity Analysis..... | 33 |

GLOSSARY

| | |
|------|--|
| AC | Alternating Current |
| B-CR | Benefit-Cost Ratio |
| CN | Canadian National Railway |
| CPR | Canadian Pacific Railway |
| CROR | Canadian Rail Operating Rules |
| CTC | Centralized Traffic Control (System) |
| DC | Direct Current |
| GDP | Gross Domestic Product |
| GEHH | GE Harris Harmon |
| GPS | Global Positioning System |
| GSM | Global System for Mobile Communication (cellular phone technology) |
| IRR | Internal Rate of Return |
| LED | Light Emitting Diode |
| mph | Miles per hour |
| NPV | Net Present Value |
| OCS | Occupancy Control System |
| OTN | Open Transport Network |
| RAC | Railway Association of Canada |
| RF | Radio Frequency |
| RSA | Railway Safety Act (of Canada) |
| SCS | Special Control System |
| TC | Transport Canada |
| TDC | Transportation Development Centre |
| TSB | Transportation Safety Board of Canada |
| UNB | University of New Brunswick |
| UPS | Uninterruptible Power Supply |
| VHF | Very High Frequency |
| VHLC | Vital Harmon Logic Controller |
| WCU | Wheel Counter Unit |
| ZPU | Zone Protection Unit |

1 GENERAL

1.1 Introduction

Since 1990, three serious accidents involving passenger trains have occurred on non-signalled sections of rail lines, causing deaths and injuries. The accidents were related to the absence of advance signals that could indicate to train crews the position of a hand-operated switch on these lines. Transport Canada (TC) has recognized the need to identify technologies that could be used to minimize the frequency and number of train accidents at switch points on non-signalled rail lines.

As a result, the Transportation Development Centre (TDC), on behalf of TC Rail Safety, retained the Transportation Group at the University of New Brunswick (UNB) to conduct a technology scan to identify the availability of systems and equipment capable of indicating the position of hand-operated switches on non-signalled rail lines.

The group prepared two surveys: one to obtain information from universities and research centres and one directed to suppliers and manufacturers (see Appendix A). Various suppliers/manufacturers and institutions in Canada, the United States, Europe and Australia were contacted. Although some did not respond to the survey, the responses were of reasonable quality. The information received indicated that potential existed for preparing and implementing a reliable and cost-effective technology to solve the problem of identifying the position of rail switches in dark territory (i.e., non-signalled rail lines) and transmitting that information to train crews.

Interviews and meetings were held in Ottawa, Montreal, Toronto and Calgary with representatives within the railway industry. As part of these meetings a test site was visited in Uxbridge, Toronto, where a system is being tested by Canadian National Railway (CN).

This report comprises five chapters. Chapter 1 presents the introduction, background, objective and scope of the study. Chapter 2 presents the methodology followed to collect information, and gives an overview of the results of the literature review, the data sources, and the interviews and visits. Chapter 3 provides an analysis of the data and Chapter 4 summarizes the findings and results, and includes a benefit-cost analysis. The conclusions and recommendations are discussed in Chapter 5. The appendices include the survey questionnaires, a list of contacts and some of the technical material obtained.

1.2 Background

The Transportation Safety Board of Canada (TSB) reported that since 1991 at least six accidents have occurred at points where trains encountered reversed switches of which the operating crews were not forewarned. This report further discloses that passenger trains have encountered reversed hand-operated switches in non-signalled territories once a year, on average, between 1993 and 2000 [1, p. 18]. Accordingly, TSB recommended that TC examine field operating

practices for the application of Rule 104 of the Canadian Rail Operating Rules (CROR) to provide adequate protection against unintentional switching of trains, avoiding potential collisions and derailments. TC consented to TSB's recommendation, replying that the rail industry and the government had initiatives of training, supervision and enforcement to safeguard and protect trains travelling on non-signalled tracks. In this regard, TC had examined railway-operating practices to assist train crews when encountering reversed switches.

Since the early 1990s CN has been involved in the development of a device to indicate the position of hand-operated switches on non-signalled rail lines to provide advance warning to train crews that a switch may not be lined for the main track [1]. TC has been monitoring and encouraging CN's efforts, indicating that consideration could be given by the railway industry to other issues, including radio communication procedures, speed restrictions and certain aspects of Advanced Train Control Systems. In addition, TC is actively involved in railway safety and is an active member of the U.S. Rail Safety Advisory Council. Canadian railways are also active in various committees and organizations within the rail operators' community.

Currently, three methods of train traffic control are practised in Canada [1]: the Centralized Traffic Control System (CTC), the Occupancy Control System (OCS) and the Special Control System (SCS). CTC has been widely used in Canada and consists of an interconnected track circuit system that is used to indicate the occupancy of main tracks, signalled sidings and signalled yard tracks. OCS is also widely used in Canada. It is a computer-assisted version of the Manual Block System that promotes accurate communication and data entry system in railway operation activities. SCS provides rules during the introduction of a new train control system.

Between May 1999 and December 2000, 14 occurrences of trains unexpectedly encountering reversed main track switches in dark territories of OCS were reported to TSB [2]. Four of the events involved passenger trains. The report concludes that, although significant safety actions have been taken by TC and the railway industry, the likelihood of additional improvements and the long-term continuation of some of these improvements was uncertain.

Despite TC's efforts to promote mitigative measures, railway accidents were not reduced significantly on the non-signalled lines. In July 2000, TC called a meeting of stakeholders, including government and industry representatives, to examine issues on the handling of main track switches in non-signalled territories. In addition, the industry was asked for actions to reduce railway accidents at non-signalled portions.

On November 14, 2000, TC issued an Emergency Directive under Section 33 of the *Railway Safety Act* (RSA) to four major federally regulated railways – CN, Canadian Pacific Railway (CPR), VIA Rail Canada and RailAmerica –to further mitigate the risk associated with the use of main track switches on non-signalled territory. The requirements of the Emergency Directive were as follows:

1. Passenger trains shall not exceed 50 miles per hour (mph) when encountering a facing point switch in non-signalled territory, until the operating crew can confirm that the switch is properly lined for their intended movement.

2. All other track movements, except for those handling special dangerous commodities shall not exceed 45 mph when encountering a facing point switch in non-signalled territory, until the operating crew can confirm that the switch is properly lined for their intended movement. Trains handling special dangerous commodities are restricted to 40 mph.
3. All employees using main track switches in non-signalled or Automatic Block Signal territory must immediately confirm to another employee by personal contact, radio, or other communication, that they have fulfilled the requirements of CROR Rule 104 by announcing that the “switch at *insert location name* has been restored for the main track (or other route authorized by Rule 104 (b))”. Employees must not leave switches unattended until they have been restored to the main track (or other authorized route), and the above-noted confirmation procedure is completed.
4. In addition to the above-noted items, the railways are required to submit detailed plans of additional measures to be implemented with regard to further mitigation of the risks associated with the use of main track switches in non-signalled territory.

TC convened an industry meeting in April 2001, to provide an opportunity for each of the affected railways to present the impact of the Emergency Directive on their operation, and to outline permanent actions that have been or will be undertaken to maintain or improve on the requirements ordered under the Emergency Directive.

On May 14, 2001, TC renewed the Emergency Directive to the four railways for a further six months.

On the same date, pursuant to Paragraph 19.(1)(a) of the RSA, TC ordered all federally regulated railway companies to revise CROR Rule 104 within 150 days of the date of this order. The revisions are to clarify the intent and application of the Rule and provide additional safety provisions when trains approach main track switches in non-signalled territory, to be inclusive of, but not limited to:

- a) speed reductions on approach to facing point switches in non-signalled territory in the absence of a system providing a physical advance indication of the switch position;
- b) communication procedures on restoring a switch to main track, which must be confirmed to another rules-qualified employee from the location of the switch;
- c) clear and distinct procedures for all operating circumstances for the handling of main track switches (i.e., within different types of limits, cautionary or yard, and the application of “in use”); and
- d) revision of any other rule that may be affected by the change to Rule 104.

In view of the foregoing, TC Rail Safety requested TDC to initiate a study on Systems to Indicate the Position of a Hand-Operated Switch on Non-Signalled Rail Lines. TDC contracted the Transportation Group of the Department of Civil Engineering at UNB to undertake the study.

1.3 Objective and Scope

This study was designed to conduct a technical and scientific review of available technologies that could be used to advise train crews in advance of a hand-operated switch that is not properly lined on a non-signalled section of rail line. It included a preliminary benefit-cost analysis to provide a general indication of the cost-effectiveness of replacing current hand-operated switch position indicators with electronic equipment.

Technical material was collected as well as information on approximate costs of acquisition, installation and maintenance of the identified technologies. To complete the study, contacts were established with researchers, universities, research centres, railway companies, suppliers and manufacturers in North America, Europe and Australia.

The survey identified various technologies, including wireless communication systems (global positioning system (GPS), radio communication, microwave systems), wayside fixed signals, data and video transmission, fibre-optic technology, automated train control systems, advance warning systems, and hazard detection systems.

2 METHODOLOGY AND SURVEY DESIGN

The surveys for technical information included:

- a) A review of technical resources from UNB libraries. The resources included reports on railway accidents (Transportation Board Safety of Canada), papers from the *Transportation Research Record* (Transportation Research Board, USA), and articles from *Rail Safety Reflexions* (TSB).
- b) An extensive worldwide search conducted via the Internet. From this search and information supplied by the study steering committee, a list of suppliers, manufacturers and transportation organizations was prepared to initiate contacts via e-mail, telephone calls and fax transmissions. Research centres and institutions in Europe and Australia were also included. A complete list is presented in Appendix B, together with brief comments on the responses.
- c) Solicitation of the opinions and comments of selected Canadian universities and university-industry liaison offices. A complete list of these institutions is presented in Appendix B. Those with potential to provide information useful to the project were followed up.

- d) Preparation of two questionnaires (see Appendix A) and sent by e-mail or fax transmissions to selected institutions.
- e) Initial contacts with suppliers and manufacturers. Based on their preliminary responses, follow-up contacts were established. These included requests to respond to the survey questionnaire and to telephone calls, and to provide technical and general information on identified technologies via e-mail and fax.
- f) Distribution of surveys to relevant universities and transportation research centres in the United States. A complete list of these institutions is presented in Appendix B.
- g) Visits to Ottawa, Montreal, Toronto and Calgary to obtain opinions and comments from representatives of TC, TDC, CN, CPR and the Railway Association of Canada (RAC). A meeting was also held with a representative of the Brotherhood of Locomotive Engineers.
- h) A visit to a test site at Uxbridge Subdivision, Toronto, to gather information on a system developed by CN. The company has been testing the system since October 2000.

2.1 Literature Review

Various sources of literature were investigated, including the Internet, the UNB Library, TC, TSB, suppliers/manufacturers of potential technologies, as well as individuals. The materials incorporated brochures, research documents, video cassettes, CD-ROMs and responses via electronic means. The details of the literature review are presented in Appendix C.

The literature review indicated that off-the-shelf technologies are available that appear to have the potential for indicating the position of a hand-operated switch in a dark territory. Some manufacturers, including ARS Networks Inc., Foster Technologies Inc. and CIMAT Power Systems, believe they can provide complete systems that could be easily implemented. Carmanah Railway Lights, GE Harris Harmon (GEHH), LaBarge Inc. and others can provide partial systems that could be integrated with the existing infrastructure to indicate the position of the switch and to provide advance warning to train crews.

Table 1 presents a summary of the most important sources of information investigated during the literature review and follow-up contact. Appendix C provides highlights of the literature review.

Table 1 Major Sources for Literature Review

| Institutions | TOTALS | |
|--|------------------|-------------------------|
| | Contacted | Useful Responses |
| Canadian Universities | 29 | 16 |
| University-Industry Liaisons | 12 | 3 |
| Organizations/Suppliers/Manufacturers | 60 | 49 |
| Other Universities and Research Centres * | 13 | 10 |
| Universities/Research Centres in the United States | 21 | 9 |
| Canadian Short Lines | 21 | 4 |
| TOTAL | 156 | 91 |
| Percentage of responses | 58.3 | |
| Other (Internet Web Sites) | 200 | - |

* *Includes Europe and Australia*

2.2 Data Sources

The following summary identifies the major data sources used in the preparation of this report. Refer to Appendix B for list a persons/companies/organizations contacted.

2.2.1 Inventory of Suppliers and Manufacturers

Over 200 Web sites were reviewed in an effort to identify companies producing systems or technologies with potential application to rail switch position indication.

From the online review a number of suppliers and manufacturers were selected as initial contacts. A questionnaire was sent to each firm to obtain general information on products/technology development with potential application to the problem under study. A list of the most relevant suppliers and manufacturers contacted is presented in Appendix B.

2.2.2 Inventory of Carriers

Information was obtained from selected railway companies, including CN and CPR. In addition, 21 Canadian short line operators were asked to provide information on the number of hand-operated switches in remote locations, as well as on miles of track where freight-only and passenger and freight trains operate.

Direct contacts were established with representatives of CN and CPR to record first-hand opinions and comments on solutions to the problem, limitations, demand, potential return on investment, and existing technologies and/or products.

2.2.3 Inventory of Universities

Canadian universities and university-industry liaison/technology transfer offices were selected for survey. American universities and transportation research centres, as well as universities and research centres in Europe, Australia and other areas around the world were also contacted.

2.3 Interviews and Visits

Visits and interviews were scheduled with representatives of TC, RAC, CN, CPR, the Brotherhood of Locomotive Engineers, and other institutions. A test site in Uxbridge Subdivision, Scarborough, was visited to view a system being tested by CN.

Following is a list of people contacted during these visits:

- Daniel Lafontaine (TC, Ottawa)
- Dennis Hutton (TC, Ottawa)
- Peter Birtwistle (TC, Ottawa)
- Peter Mayer (TC, Ottawa)
- Dough J. Vollick (TC, Surface, Toronto)
- Mike Lowenger (RAC)
- Mike Regimbal (RAC)
- Ray B. Kroeker (CN)
- Terry O'Shell (CN)
- Robert Nash (CPR)
- Benoit Brunet (Brotherhood of Locomotive Engineers)

3 ANALYSIS OF MATERIAL REVIEWED

3.1 Discussion of Relevant Materials

This section outlines those technologies/systems that exhibit potential to meet or partially meet the requirements for indicating hand-operated switch position.

- A GPS location system should be relatively easy to adapt for use on a locomotive. It should be fairly simple to map the GPS location of each switch. An alert could be relayed to the cab of the locomotive as it approaches each switch. The crew could then observe the manual switch signals to make sure that the switch is in the correct position.

The next level would be to install a low-cost switch position sensor and a short-range radio transmitter. As the train approaches each switch, its location and status would be received in the cab of the locomotive.

- A video surveillance system was also identified; however, the system may have limitations in fog, heavy rain or snow.
- The literature indicated that the position of the switch can be monitored using different scenarios including:
 - detecting the position of a magnet on the switch relative to a sensor on the track;
 - measuring the conductivity (e.g., establishing a link between the switch and a variable resistor, then measuring the voltage or current between these two points);
 - optically lining up a Light Emitting Diode (LED)/photodiode pair or a laser proximity sensor;
 - using an ultrasonic proximity sensor or a radar proximity sensor.
- A solar power option for the system depends on the level of energy and power requirements of the system components. If batteries are needed, then temperature, self-test and maintenance are issues to consider. Cost is also a consideration. If a convenient power supply is nearby, the solar option could be relatively expensive, but if the system must stand in a remote location it could be a low-cost choice.
- Communication systems may include a central traffic control centre collecting information on the switch network and transmitting the status to each train as it approaches a switch. Another approach could be a lower bandwidth solution, whereby the train would activate a communication to poll the switch from a pre-determined distance in advance.
- Some ventures in switch position determination have used wayside indication units and radio frequency (RF) for transmission. However, none of them have proven to be practical and cost-effective. An important issue relative to the implementation and/or production of a technology is the potential return on investment. Systems are currently being employed for remote control of switches via radio communication. However, these systems are used at low speed, for example, in terminal yards, or where the switch locations are in close proximity to each other.
- A GPS-based remote hazard detection system could be applicable. A low-cost device at the switch location combined with an inexpensive on-board unit could provide an engineer with advance warning if the switch is not in the right position. The only requirement is that the hand-operated switch provides (or be modified to provide) a set of electrical contacts that indicate the position of the switch (simple normally open or normally closed contacts are all that is necessary). A system could be powered by solar energy or from the AC main if available. Such a system has been tested at the Worcester Polytechnic Institute. The prototype cost is estimated by the developer to be approximately US\$500 per switch. A total of 100 switch units could produce a target cost of approximately US\$500 to US\$1,000 per

switch. The approximate cost of the hardware for installation in the locomotive is estimated to be between US\$1,000 and US\$1,500. The installation and maintenance costs are estimated to be minimal. However, the on-board locomotive costs are not included.

- The use of a centrally controlled system to monitor the status of the switch network could entail several problems. First, it would require significant additional infrastructure to communicate information to the central structure and then back to the engineer. Second, significant costs would be associated with maintenance of the system and the infrastructure, as well as with training and staffing of operators.
- The use of an on-board video camera that can detect a nearby hand-operated switch may not be effective at night or in inclement weather. In this case the line of sight to the indicator of the switch would be insufficient. Infrared imaging may mitigate the night vision problems but the system would still be subject to problems in poor weather. Video monitoring systems could also distract the crew from other duties. A feasible solution might be to use some form of active telemetry, where the switch continually broadcasts its status, or some form of radar or sonar to locate the switch from the locomotive. These options may suffer from poor spectral efficiency, or from line-of-sight problems.
- Union Switch & Signal of Pittsburgh, Pennsylvania, USA, stated knowledge of some ventures in switch position determination using wayside indication units and RF for transmission. However, its main concern is to ensure that the market would support the development of the technology and provide a reasonable return on investment.
- Power Conversion Products LLC offers remote and local monitoring of DC power systems (rectifiers, battery, and power distribution board), and provides local and remote status and alarm conditions as well as some control functions. Control actions are limited to setting alarm levels, activating single or dual low-voltage disconnects, and automatic callback via phone line.
- The Department of Electronic and Electrical Engineering at the University of Strathclyde in the United Kingdom is involved in railway switch research. It was involved in the development of video transmission between train and track-side using GSM channels, technology that would be capable of monitoring a switch condition. However, some investigation of the precise conditions of operation would be required. The Department noted that several technological innovations, including mobile base stations, exist in the United Kingdom.
- CN has developed a technology for Switch Position Indication in dark territories. The system has been under test since October 2000. An analysis of data log results indicates that it is reliable and meets the requirements to indicate the position of a hand-operated switch and transmit a warning signal to an approaching train.

The system comprises:

- a data logger (to record information on the operation of the unit);
- radio equipment to transmit the signal on switch position;
- two directional antennas (SCADA LINK - BENTEK SYSTEMS) for transmitting and receiving information on switch status (normal or reversed);
- a set of four batteries for power backup;
- a solar panel to charge the batteries;
- signal lights powered by the batteries;
- interconnects from the switch to the data logger and signal lights.

The switch circuit controller monitors the position of switch points. If the switch is in reversed position (over ¼" from the main track), a signal will be transmitted through radio communications to activate a relay at the receiving point for a red flashing light to be activated. If the position of the switch is normal (less than ¼" from main track) then the white light will stay on. In the event of failure of any system component, the red light will activate. If no indication is given by the lights (i.e., if a fuse burns out), the train crew will assume that the red light is flashing and should bring the train to a safe stop. More details on the system are included in Appendix C. The estimated cost for a simple system is CAN\$13,000. The cost of a system that includes feeding to the lighting system around a curve is estimated at CAN\$35,000. Maintenance costs appear to be marginal.

- CIMAT Power Systems of Pointe-Claire, Quebec, Canada, supplies high-quality DC circuit components with an emphasis on remote site power equipment. It produces autonomous beacon systems that could be incorporated into the signalling system to alert the train crew on the status of a hand-operated switch. Installation appears straightforward and uncomplicated. Maintenance is minimal. Visual sight lines could be a problem. The system power is 12 volts DC. Each system consists of the following components:
 - long-life (10-15 years) LED light assembly;
 - long-life (approximately 20 years) solar panels with mount;
 - solid-state electronics with lightning and surge protection;
 - long-life, freeze-tolerant, deep cycle batteries;
 - battery enclosure (ground and pole ground);
 - cabling and components interconnects.

The solar-powered beacon assembly costs CAN\$3,321 not including taxes, on the basis of using red and green lights (a white light would be more expensive). This price includes all power (batteries), control, lightning and mounting components, with the exception of the pole and light housing and mount (this may be provided on request at additional cost). Batteries are specified to seven days autonomy at -20°C. If the voltage goes down at any moment, the lights will start flashing to indicate that maintenance and/or check-up is required. A schematic of the system components is presented in Figure 1.

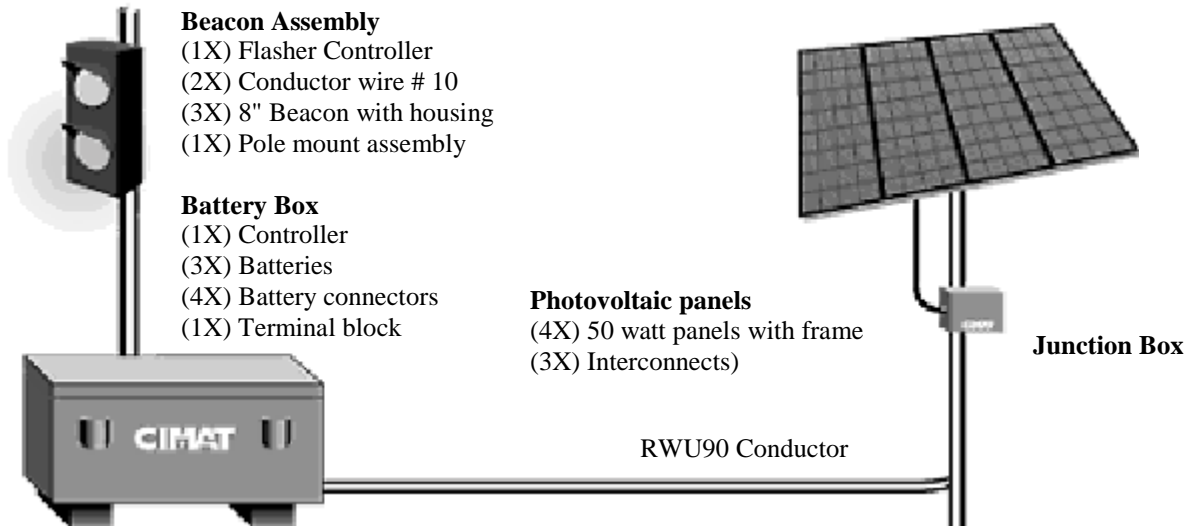

Figure 1 Autonomous Beacon System

Source: CIMAT Power Systems (www.cimat.com)

CIMAT Power Systems also provides a low-voltage DC power supply consisting of the following components as standard equipment:

- tamper-resistant enclosures and components;
- programmable 4-circuit data logging;
- solid-state electronics with lightning and surge protection;
- long-life, low-maintenance, freeze-tolerant, deep cycle batteries;
- circuit protection from over- and under-charging;
- cabling and component interconnects;
- real-time circuit status.

The true on-line uninterrupted power supply (UPS) assembly, shown in Figure 2, would cost CAN\$1,326 not including taxes. The system includes all power, control, lightning and mounting components, with the exception of the pole and light housing and mount. Batteries are specified to 18 hours autonomy at -20°C.



Figure 2 Low Voltage UPS

Source: CIMAT Power Systems (www.cimat.com)

This company is also a supplier of solar panels. A price list for these products follows.

Table 2 CIMAT Power Systems Solar Panels Price List

| Part No. | Power (watts) | Nominal Voltage | Price (US\$) | Price (CAN\$) | Dimensions | Manuf. Warranty (years) | Cost per Watt (US\$) |
|------------|---------------|-----------------|--------------|---------------|------------------|-------------------------|----------------------|
| MSX-120/12 | 120 | 12 | 870.97 | 1,350 | 45" x 39" x 2" | 20 | 7.26 |
| MSX-120/24 | 120 | 24 | 870.24 | 1,350 | 44" x 26" x 2" | 20 | 7.26 |
| MSX-0.83 | 83 | 6 or 12 | 611.61 | 948 | 44" x 26" x 2" | 20 | 7.37 |
| MSX-077 | 77 | 6 or 12 | 554.84 | 807 | 44" x 20" x 2" | 20 | 7.21 |
| MSX-064 | 64 | 6 or 12 | 484.14 | 702 | 44" x 20" x 2" | 20 | 7.56 |
| MSX-060 | 60 | 6 or 12 | 465.81 | 722 | 44" x 20" x 2" | 20 | 7.28 |
| MSX-056 | 56 | 6 or 12 | 408.39 | 633 | 44" x 20" x 2" | 20 | 7.29 |
| LBK-050 | 50 | 6 or 12 | 336.13 | 521 | 37" x 20" x 2" | 10 | 5.72 |
| BPS-090 | 90 | 12 | 580.65 | 900 | 47" x 20" x 1.5" | 20 | 6.45 |
| BPS-075 | 75 | 12 | 483.87 | 750 | 47" x 20" x 1.5" | 20 | 6.45 |
| CRM-075 | 75 | 12 | 398.71 | 618 | 46" x 21" x 1.8" | 12 | 5.32 |
| CRM-065 | 65 | 12 | 338.71 | 625 | 46" x 21" x 1.8" | 12 | 5.21 |
| CRM-060 | 60 | 12 | 321.29 | 498 | 46" x 21" x 1.8" | 12 | 5.35 |
| CRM-050 | 50 | 12 | 299.35 | 464 | 38" x 17" x 1.6" | 12 | 5.99 |

* Prices may change at any time

Source: CIMAT Power Systems (www.cimat.com/products/price_list.html)

- Carmanah Railway Lights, of Victoria, British Columbia, Canada, supplies railway safety and hazard marker lighting, among other products. It also provides a no-maintenance solar-powered LED solution that could be easily installed and is reported to operate reliably for up to 5 years.

This company currently provides two models:

- Model 209 for directional blue-light signalling applications (see Figure 3);
- Model 509 (360° Blue Light) (see Figure 4).

These are solar lights that can be temporarily or permanently installed for all types of directional blue-light warning applications. They are completely self-contained and require no maintenance or service for their entire lifespan of up to 5 years. Once installed, the unit charges itself during the day, even under cloudy conditions, and turns on automatically to emit a steady or flashing blue light throughout the night.

The approximate cost of each unit is US\$199 for Model 209 and US\$229 for Model 509. Table 3 lists the prices according to the order size for both models.

Table 3 Price List Depending on Order Size (US\$)

| Item | Order Size (units) | | | | |
|-----------|--------------------|----------|----------|----------|----------|
| | 1 - 5 | 6 - 20 | 21 - 50 | 51 - 100 | > 100 |
| Model 209 | \$199 | \$179.10 | \$169.15 | \$159.20 | \$149.25 |
| Model 509 | \$229 | \$206.10 | \$194.65 | \$183.20 | \$171.75 |

These lights are reported to be extremely durable, waterproof and vandal-resistant. They do not require any external electrical source or battery replacement. They are available in different colours including red, blue, amber, green, blue and white.



Figure 3 Carmanah Light Model 209



Figure 4 Carmanah Light Model 509

More information on these products is available in the technical literature in Appendix C.

- Siemens ATEA of Austin, Texas, USA, supplied technical information on an Open Transport Network (OTN). This is a transmission system based on fibre-optic technology. Signals from hot box detectors, wheel load impact detectors, and automated train control systems can be fed into the OTN multiplexers and brought back to a Central Control Centre via a double fibre-optic ring.

The railway resilience is accomplished via OTN nodes, which are connected in dual ring. This structure allows the network to work around cable breaks and product failures, without affecting the devices connected to the nodes, thus achieving optimal network and railway availability. The distance between the nodes can be up to 150 km, allowing OTN rings exceeding 2,000 km to be constructed.

Some Siemens ATEA representatives believe that if the intent is to cable the right-of-way where the hand-operated switches are located back to a fibre-optic node, then some available Siemens ATEA technologies could be suitable for transmitting the status of hand-operated switches to a remote node for annunciation to a dispatcher or for interfacing to an existing radio network. However, these technologies may not be cost-effective if the OTN system is not intended to handle voice, data or video applications to offset the cost of installing a fibre-optic cable plant. Therefore, at this time, implementing these technologies does not seem to be cost-effective. More detailed information is included in Appendix C.

- From the Internet, e-mail contacts and telephone conversations with representatives of GEHH, the following information was obtained.

GEHH does not produce a device directly intended to indicate the position of a hand-operated switch. However, assuming that power is available in remote areas, some systems could be used. The company produces a system called Vital Harmon Logic Controller (VHLC), which could be used to light a lamp indicating that the switch is in normal position. The VHLC provides control of power-switch machines and direct control of signal lamps and mechanisms.

Another product offered by GEHH is a Solid State Switch Monitor. This system comprises two Programmable Logic Units with proximity sensors mounted on each switch point. These sensors check the position of the switch.

GEHH also produces a DEMA – Monitor/Annunciator. It is used to monitor highway crossings and signal control points for proper operation and to report any alarm conditions to train crews via an on-board VHF radio. Programs can be added to the monitor to increase its capacity to provide tests and alarm signals.

Detailed information on acquisition, installation and maintenance costs for these systems was unavailable. A description of the systems, along with some technical information, is included in Appendix C.

- Kapsch AG - Railway Communications Systems is an Austrian firm that offers traffic control and communication systems for road and rail operators to monitor and guide traffic flows.

The company provided some technical information on radio communication systems for the rail industry. However, the technologies it offers can be obtained from North American companies. More information can be found in Appendix C.

- The following comments and opinions on potential solutions to the problem were received from a contact at the Massachusetts Institute of Technology, Centre for Transportation Studies:

Some off-the-shelf solutions to the problem of switch position indication are available. Any solution should be based on measuring or monitoring the physical position of a moving part.

Solutions could include detecting the position of a magnet on the switch relative to a sensor on the track, and linking the switch to a variable resistor. Depending on the position of the switch, a voltage or current will appear, triggering a warning signal (audio or visual) to alert the train crews.

- The Worcester Polytechnic Institute in Massachusetts, USA, has developed a Railroad Hazard Detection System that was successfully tested on a locomotive. The technology has proven its potential, and now requires a large-scale test.

The system consists of three components

- A GPS Train Unit mounted on the locomotive. Information on the switch identifier and the switch distance appear on the unit's LED display. The system can sense the switch within a range of two miles. When the train enters this sense zone, an indicator light alerts the crew in the locomotive cab to the presence of a switch. The system then monitors the remote site where the switch is located using radio communication. Depending on the result of this query, indicator lights will turn on (green for GOOD status, red for BAD status). If the indication is a red light an audible signal is emitted.
- A Handheld Programming Unit to gather the GPS coordinates of remote switches and transmit them to a database.
- A Remote Switchsite Unit mounted on a pole near the track switch. The unit interfaces to the track using a standard track switch and disconnects power to the radio transceiver when the track is positioned more than ¼" off the main line. Since no communication can be established between the radio and the GPS Train Unit, a "bad" status is issued to the train crew in the locomotive.

This system can detect remote track switch hazards at a distance of two miles and provides the train crew adequate time to stop the train if a "bad" status exists at the remote switch location.

According to the developers, a low-cost, GPS-based remote hazard detection system at the switch location, combined with an inexpensive unit in the locomotive, can provide an engineer with advance warning when the switch is not in the correct position. The only

requirement for such a system is a set of electrical contacts on the switch to indicate its position (normal or reversed).

- In a telephone conversation, Mr. Bill Moore Ede of CANAC Inc., Montreal, Quebec, Canada, said that off-the-shelf technologies are available to solve the problem of switch position indication. These technologies are easy to implement and would provide additional safety to the railway network. He underlined the importance of setting appropriate standards and regulations if the technologies are to be effective in providing safety to railway operations in North America.

- A technical proposal was received from ARS Networks Inc. of Champlain, New York, USA. The system comprises:
 - Two transducers mounted on the switch point throw rods to indicate the position of the switch, either open or closed. The transducers are hard-wired to a Node Processor mounted on a pole at trackside.
 - A Node Processor, which is a microprocessor that receives the signals from the transducers and converts the signals to indication light commands.⁽¹⁾
 - A set of signal lights. The system can support a one-, two- or three-light design, depending on client and location requirements. Where sightlines are a problem, a minimum of two lights will be required, one in each direction away from the switch point.
 - A Spread Spectrum Radio, which is required in the multi-light design to relay the switch point indication to remote lights. Directional antennas are installed to transmit signal information.

Poles and a security box to include the batteries are also supplied.

The Node Processor continuously checks the transducers for their indication. The processor takes the information and converts it to a light indication command. In the multi-light design, this command is relayed by spread spectrum radio to the remote light locations.

Cost of the System

The manufacturer will supply a system that includes:

- transducers;
- node processor;
- antennas;
- light systems;
- spread spectrum radios;
- pole and security box for the batteries.

⁽¹⁾ Processor design and specifications not available. They are exclusive to ARS Networks.

With a minimum order of 10 systems the cost, not including installation, would be:

- US\$10,000 for a one-light system
(One bi-directional light at the switch point location at trackside)
- US\$25,000 for a three-light system
(One bi-directional light at switch point location and two remote lights at trackside)

The base unit is designed assuming that power is available at trackside. However, solar panels can be installed as an option. This optional system includes the solar panel and battery backup, which are provided at additional cost. Although prices may vary, depending on client requirements and size needed, each solar panel is estimated to cost US\$2,000 and the batteries would be in the range of US\$2,500.

The fail-safe operation of the system is established by having the lights off as an indication that the switch point position is undetermined or compromised. If the power source fails, the lights would be off, giving the most restrictive indication to the train crew; that is, to be prepared to stop the train at the switch point location.

No on-board equipment is required. The warning relies on visual observation of the signal lights. On board systems could be included at an increased price. In that case a receiver would be needed in the locomotive and a microprocessor would have to be designed to send a radio signal to the locomotives. They would be costly unless compatible equipment is available on locomotives.

- EVA Signal Corporation of Omaha, Nebraska, USA, was also contacted by telephone. A sales representative said that the company is not involved in producing any system or technology that could be applied to switch position indication. The company provides systems for automatic train detection, rail-crossing warning systems, warning of trains approaching work zones, etc. The representative considers that none of these systems would meet the requirements for indicating the position of a hand-operated switch in remote locations to the train crew.
- Contact was established with Foster Technologies Inc., a division of L.B. Foster Company in Burlington, Ontario, Canada. First-hand information was obtained from a visit to the Railway Exhibition held in Moncton, New Brunswick June 6 -8, 2001, on a Switch Point Protection System (SPPS) based on the principle of count-in/count-out systems. Detailed information on installation, operation and maintenance of the system is presented in Appendix C.

The basic components of the system include:

- Sensor heads – Wheel Counter Unit (WCU)
- Zone Protection Unit (ZPU)
- Sensor Drive Assemblies

The sensor heads (WCU) are mounted on the rail at each end of the protection zone, rather than by cutting both rails and installing insulated joints. By counting the number of wheels entering or leaving a specific area, the sensors can determine whether any equipment is within the zone. Wheels entering the zone cause a positive count and wheels leaving the zone cause a negative count. Simple addition logic determines whether there is any axle in the zone and deactivates an indication output unless the total count is zero. The sensors can also detect the direction of the movement; therefore, trains stopping or backing up cause no logic problems to the system's operation.

The ZPU polls the WCUs every 50 ms. When a train is detected entering the zone (noted as a positive wheel count), the transformer coupled output is deactivated to prevent the switch from being operated. As the train leaves the zone (noted as a negative wheel count), the output is reactivated when the net wheel count reaches zero. Autoline is available for trains entering the normal or reverse trailing end of the switch; another two outputs are configured for this use. The system can be programmed to self-restore the switch. When the last wheel leaves the protected zone through the reversed switch, the switch returns to normal position after 10 seconds, as long as no other train has entered the protected zone.

The total cost of the complete system is estimated to be approximately CAN\$20,000 including installation costs. Minimum maintenance should be required on the system with only routine inspections every three months to verify the status of the components and system adjustments. Complete information on system installation and operation along with a detailed description of each component is included in Appendix C.

- North American Signal, Inc. of Jacksonville, Florida, USA, specializes in transportation control systems with emphasis on wireless data transmission. They produce a device (NAS 2001 DTMF Controller) that is designed to transmit switch position in yards and wayside sites. Remote indication can be provided via voice annunciation over a two-way secure radio system or by wireless communication to a controller at a wayside signal indicator site (i.e., signal light) for direct display to the train crew.

Product applications include:

- Remote control and indication wayside of switches and yard switches
- Defect detection
- Remote message or alarm annunciation
- Auto-dialler for maintenance personnel
- Mobile base station control
- Traffic device monitor
- Remote security monitoring

The unit can be interconnected to the switch and to signal lights to provide warning to an approaching train. This system is currently used for switch position indication in railway yards.

The unit itself is estimated to cost US\$950 and can be powered from the main track or from a DC power supply (batteries). The backup batteries, solar panel and indication signals (lights) would add to the cost. The approximate cost of a complete ready-to-install system is reported to be less than US\$2,000. However, depending on the application requirements, installation costs may vary. More information on this product is included in Appendix C.

- LaBarge Inc. of St. Louis, Missouri, USA, manufactures a wireless remote monitoring device (CellularRTU) that could monitor switch position [3]. The status of remote equipment could be accessed over the Internet or through a private intranet. This is, however, an exception-based system and is not designed to send messages frequently or to send large amounts of data. The system uses the administrative control channels of the analog cellular network deployed throughout North America. An alarm message can be sent from a field Cellular Radio Transmission Unit, which requires an external power source, to a mobile pager, using a Web Messaging service. The alarm message can also be sent to a dispatch centre over the Internet, by e-mail, or directly into the centre, using a variety of communication protocols. Remote sites could be monitored 24 hours a day via the Internet. An unlimited number of recipients could be set up to receive the information from a remote location via e-mail, cellular telephone, pager or fax transmission.

The existing analog cellular network should be sufficient to handle the transmission. There are, however, some limitations. Although coverage is excellent in the Quebec City-to-Windsor corridor, including Ottawa, and fairly good in some areas of New Brunswick and Nova Scotia, there are large gaps in Northern Ontario, with almost no coverage from Sault Ste. Marie to Thunder Bay. Coverage picks up again at Kenora and goes west through Southern Manitoba, the lower half of Saskatchewan and the southern two-thirds of Alberta. There may be additional requirements for communications protocols; however, this would have to be determined after deciding on the basic system meeting the desired requirements.

Messages could be sent directly to the train crew, provided the locomotive is equipped with pagers with nationwide service and Web-messaging capability. One possible drawback would be the noise in the cab of the locomotive, which might make the pager beeper inaudible. E-mails could be sent to the dispatch centre as well. No other on-board equipment would be required in the locomotive. Messages cannot be sent continuously, since there is a penalty for excessive messaging from any unit in a given cellular market. Therefore, monthly charges for the cellular service may increase significantly. More information on the technology is included in Appendix C.

- Jasmin SIMTEC Ltd. of Nottingham, England, United Kingdom, submitted a written proposal for developing a switch monitoring transport network. This technology raises the problem of using on-board equipment for visual and audible warning signals to the train crew. The main limitation of the technology is the likely failure in the presence of heavy and prolonged snow, which makes it unsuitable for Canadian conditions. Nonetheless, the submitted proposal is presented in Appendix C.
- Dr. Bruce Colpitts, a professor in the Department of Electrical and Computer Engineering at UNB, who has been conducting research in the field, stated that products are commercially

available to develop applicable technologies at a relatively low cost. Two different approaches could be taken. The first system would be based on radio communications, using the registered frequencies for railway operations. A transmitter would be required at each individual switch location to transmit a radio signal directly to the train. The only requirement would be that unique identification would be necessary for each switch for the train crew to know the exact location of each independent switch and its status. The main advantage of this approach is the elimination of signal lights to indicate the status of the switch. This would eliminate the cost of acquiring signal lights as well as of installation and maintenance. In addition, the electronics involved would be more durable than a bulb light, which reduces the reliability of the system while increasing costs. However, depending on implementation methods, such a system could result in safety and workload issues.

A second approach involves the transmission of the status of a switch from the switch site to a satellite. The information could then be transferred to a dispatch centre and from there to the locomotive.

Safety is a critical issue when implementing these types of technologies. It is possible to develop a straightforward system that meets the requirements in terms of providing an advance warning to the train crew; however, the system must provide a high level of reliability and durability at low cost.

3.2 Identification of Technologies with Potential Application

The information obtained from the literature search was evaluated and a screening process was carried out to identify those technologies with potential for addressing the switch position indication problem. The analysis of potential technologies and/or products was based on:

- suitable application to the existing railway infrastructure;
- major advantages and disadvantages;
- estimated cost (acquisition);
- system characteristics (whether the supplier/manufacturer can provide a complete system or a partial system, e.g., power supplies, batteries, solar panels, lights).

Factors considered included:

- technology being the only cost-effective option;
- analysis of the cost of the solution and the severity of hazard being mitigated.

Those technologies that appeared to have a potential application to the study issue are listed in Table 4. They are not presented in order of priority. A more complete description of all the identified technologies is provided in Section 3.1 and in Appendix C.

Table 4 Technologies with Potential for Application to Hand-Operated Switch Position Identification

| No. | TECHNOLOGY/PRODUCT NAME | SUPPLIER | MAJOR ADVANTAGES/ DISADVANTAGES | ESTIMATED ACQUISITION COST |
|------------|--------------------------------|-----------------------------------|--|--|
| 1 | Autonomous Beacon System | CIMAT Power Systems (Canada) | Complete system. Long life (10-15 years). Weatherproof. Solar power. Minimal infrastructure requirements. Minimum maintenance. Simple installation. Inexpensive, fail-safe system. | CAN\$3,321 |
| 2 | NAS 2001 DTMF Controller | North American Signal, Inc. (USA) | Partial system. Controller unit inexpensive. Current application in yard switching. A complete system can be supplied upon request. Disadvantage: if a complete system is required, components from different suppliers may be involved. | Controller: US\$950 Complete system (batteries, solar panel, lights): less than US\$2,000 |
| 3 | Switch Point Protection System | ARS Networks, Inc. (USA) | Complete system. Simple technology. Fail-safe system. Disadvantage: expensive. | US\$10,000 to US\$25,000 |

Table 4 (cont.)

| No. | TECHNOLOGY/PRODUCT NAME | SUPPLIER | MAJOR ADVANTAGES/ DISADVANTAGES | ESTIMATED ACQUISITION COST |
|------------|-----------------------------------|-----------------------------------|---|--|
| 4 | Switch Point Protection System | Foster Technologies Inc. (Canada) | Complete system. Direction of movement can be detected. Fail-safe system. No maintenance required. Automatic switch operation. Disadvantage: requires installation of a hydraulic switch machine, initial system set-up and adjustments may require training personnel. | CAN\$20,000 (including installation costs) Hydraulic switch machine: CAN\$6,700 |
| 5 | Switch Position Indication System | Canadian National (Canada) | Complete system. Easy to install, minimal maintenance. Relatively inexpensive. Proved to be reliable and effective. | Simple system (no curves): CAN\$13,000 System around a curve: CAN\$35,000 |

Table 4 (cont.)

| No. | TECHNOLOGY/PRODUCT NAME | SUPPLIER | MAJOR ADVANTAGES/ DISADVANTAGES | ESTIMATED ACQUISITION COST |
|------------|---------------------------------------|----------------------------------|---|---|
| 6 | Directional Lights (Models 209 & 509) | Carmanah Railway Lights (Canada) | Partial system. Relatively inexpensive. Modifications are required to meet railway requirements. | Varies depending on order size. See Table 3, Section 3.1. |
| 7 | Vital Harmon Logic Controller (VHLC) | GE Harris Harmon (USA) | Partial system. Provides direct control of signal lamps and mechanisms. Replaces most vital and nonvital relays at an interlocking. | Unavailable |
| 8 | Solid State Switch Monitor | GE Harris Harmon (USA) | Partial system. Disadvantage: modifications to the railway infrastructure may be required. | Unavailable |

Table 4 (cont.)

| No. | TECHNOLOGY/PRODUCT NAME | SUPPLIER | MAJOR ADVANTAGES/ DISADVANTAGES | ESTIMATED ACQUISITION COST |
|------------|---|------------------------|---|-----------------------------------|
| 9 | DEMA-Monitor/Annunciator | GE Harris Harmon (USA) | Partial system. Disadvantage: not originally designed for switch monitoring. Modification may be required. | Unavailable |
| 10 | Wireless Remote Monitoring Device (CellularRTU) | LaBarge Inc. (USA) | Complete system. Uses the existing administrative channels of cellular network. Disadvantages: no cellular coverage in some areas. Relies on messages being sent via e-mail or Internet. Train crews should be equipped with pagers, which may not be audible in the noisy environment of a locomotive. Limited number of messages to send. | Unavailable |

4 SUMMARY OF FINDINGS AND RESULTS

4.1 Reliability of Identified Technologies

This section presents comments on the reliability of the technologies listed in Table 4. The analysis is based on the characteristics of the technologies in terms of the apparent functionality of the systems, depending on whether complete technologies or individual components are provided by suppliers and manufacturers.

A complete system would be specifically designed for monitoring the status of the switch and then transmitting a warning signal to an approaching train or a dispatch centre. A partial system can be defined as one that furnishes only one or more components or products to be integrated with another product or technology to assemble a complete system.

A complete system would provide ease of installation at a lower cost than a partial system. It would be more cost-effective to acquire a system with all components rather than having to integrate individual products from different suppliers to develop a system meeting the desired requirements. Using complete technologies would be the most feasible solution to reduce costs and to provide maximum efficiency in operation and maintenance of the system. Using partial technologies may increase acquisition, installation and maintenance costs without a significant increase in the reliability and effectiveness of the system, as compared to a commercially available complete technology.

In the opinion of the study team, based on the technical information available from suppliers and manufacturers, complete technologies should be applied so as to assure the highest level of reliability in indicating the position of a hand-operated switch in dark territories.

Of the technologies identified in Table 4, the following, in descending order, are considered to have the highest probability of successful application. Reference is made to the product number as indicated in Table 4.

- **Product No. 1:** Autonomous Beacon System supplied by CIMAT Power Systems
- **Product No. 5:** Switch Position Indication System implemented by CN
- **Product No. 10:** Wireless Remote Monitoring Device supplied by LaBarge Inc.
- **Product No. 7:** Vital Harmon Logic Controller supplied by GEHH
- **Product No. 4:** Switch Protection System provided by Foster Technologies Inc. (this technology may be useful in detecting traffic flows and direction of movement, which may facilitate train management operations and train traffic control)

4.2 Estimation of Demand

A number of potential suppliers/manufacturers and researchers stressed that the technology to address the issue either exists or could be easily developed. The major difficulty, in their opinion,

was the lack of demand for the technology. For this reason an estimate of the demand for units to monitor the position of hand-operated switches in dark territories in Canada was attempted. Data were collected from RAC, CN and CPR. According to RAC there are at least 5,000 switches in 14,000 miles of non-signalled tracks. CN's data show there are 3,500 switches in dark territory on 6,000 miles of freight train operations, of which 600 are in dark territory where passenger trains also operate. CPR estimated it operates a total of 2,000 switches. For purposes of completing a preliminary benefit-cost analysis, this study has taken 6,500 as being the demand level if all hand-operated switches in dark territories were to be upgraded.

4.3 Acquisition and Implementation Costs

Costs of available technologies were provided by different organizations, suppliers and manufacturers for both partial and complete systems. CN provided cost estimates of CAN\$13,000 for a simple system to be installed where curves were not present, and CAN\$35,000 for curve locations. ARS Network Inc. provided costs for a complete system, based on a minimum order of ten systems. The cost of a one-light system is US\$10,000, while a three-light system would cost US\$25,000.

Costs were also provided by CIMAT Power Systems for complete and partial systems. A complete unit would cost approximately US\$3,321, whereas a partial system cost was set at US\$1,326. Costs include power supply, batteries and installation.

Caramanah Railway Lights provided cost information on a partial system. It manufactures two types of models of signal lights. The cost is US\$199 and US\$229 for Models 209 and 509, respectively.

A complete system can be acquired from Foster Technology for an approximate cost of CAN\$20,000 including installation. The Worcester Institute of Technology has developed a product that costs US\$500 for a prototype system. For an operative switch unit the cost would be US\$500 to US\$1,000 per switch for production of 100 units. North American Signal, Inc. provides a complete technology for US\$2,000. These costs do not include installation.

Based on the above, costs of CAN\$10,000 and CAN\$15,000 per switch were used in this analysis.

4.4 Benefits

A benefit-cost analysis was undertaken as part of the study to provide a ballpark estimate of the economic benefits that could be realized from the introduction of a technology to lower the number of accidents related to hand-operated switches located on non-signalled sections of rail lines. The quality and quantity of data on factors used in a benefit-cost analysis directly affects the sensitivity of the findings.

The factors on which further data and/or refined data are required include accident rates and types, accident costs, technology costs (including installation), travel time savings, travel time costs, and traffic growth rates.

The data available for this study did not permit a detailed benefit-cost analysis. However, the analysis was of sufficient reliability to indicate that benefits should be realized from the introduction of a cost-effective technology.

4.4.1 Savings from Reduced Property Damage, Personal Injuries and Fatalities

Benefits from the implementation of the system were quantified. Benefits are considered to occur from savings related to reduced property damages, personal injuries, fatal accidents and running time. Costs depend on the severity of accidents. In the case of injuries and fatal accidents, the 1990 insurance costs were provided by TC. These values were adjusted for 2001 using GDP deflators. Accordingly, insurance costs for personal injuries and fatalities were estimated to be CAN\$75,000 and CAN\$2 million, respectively.

Damage cost estimates were obtained from RAC. The costs of railway accidents differ significantly. According to RAC, 80 percent of incidents do not result in collision or derailment. In some of these cases, costs are incurred for the repair/replacement of switches, amounting to not more than CAN\$1,000. However, some collisions involved costs greater than CAN\$1 million. According to RAC, 17 incidents have occurred on one railway since 1990. Of these, 14 did not result in derailment or collision, whereas three resulted in average damage costs of approximately CAN\$1.3 million per incident. RAC provided average property damage costs of CAN\$230,000. These costs were used in the analysis.

4.4.2 Passenger Travel Time and Cargo Transport Time Savings

Benefits also include time savings to passengers and cargoes from speed adjustment after implementation of a system. There are approximately 14,000 miles of non-signalled tracks in Canada. This accounts for approximately 35 percent of the total 38,545 miles nationwide. Speed for passenger trains has been restricted by TC to 50 mph when encountering a facing-point switch in non-signalled territory. All other track movements, except for those trains handling special dangerous goods, are restricted to 45 mph and trains handling special dangerous goods to 40 mph.

CN operates lines with approximately 3,500 switches, which include 600 on lines over which passenger trains operate. Other operators did not provide data on switches or track mileage. It is assumed that, out of the total 14,000 miles in non-signalled territory, 3,000 miles correspond to passenger-train domain and the remaining 12,000 miles are under freight-train domain.

The number of intercity passengers was approximately 6 million in 1999, with about 2 million passengers (35 percent) travelling in non-signalled territory. During the same period,

approximately 290 million tonnes of cargo were transported, with about 102 million (35 percent) in non-signalled territory.

If the speed limit is raised to 60 mph for passenger trains as a result of implementing a specific system, the total number of running hours saved per passenger would be 10 hours per passenger per year in non-signalled territory. Similarly, if a freight train operates at a speed of 50 mph instead of 42.5 mph, (average of 45 and 40 mph), the savings would be approximately 40 running hours per tonne per year in non-signalled territory. Therefore, the total time saved as a result of speed improvement would be 20 million hours for passengers and 4,100 million hours for freight trains per year. The average annual growth between 1990 and 1999 was 2.5 percent in passenger-miles and 3.2 percent in freight-tonne miles.

Time values of passengers and cargoes were estimated during testing of the Highway Development and Management Tool (HDM-4) for its application in Canada [4]. Passenger working time was estimated at \$17.00/hr and non-working time at \$4.25/hr. Although most of the passengers are commuters, the time spent on trains is non-working time since they start their journeys early to arrive at work on time. However, some working time may be sacrificed. Thus, 25 percent of the time was considered as working time and 75 percent was estimated to be non-working time. The weighted average value was calculated to be \$7.50/hr. Cargo time for heavy trucks was estimated at \$18.75/hr. The capacity of a B-Train truck is about 60 tonnes. The cost per tonne is therefore estimated at \$0.30/hr. Based on the above calculations, benefits were estimated for the period 2001-2010.

4.5 Estimation of Accidents

Train accidents occur in many forms, including main-track collisions, main-track train derailments, crossings, non-main-track collisions, non-main-track train derailments, collisions/derailments involving track units, employee/passenger accidents, trespasser accidents, and fires/explosions. Samples of train accidents are leakage of dangerous goods, main-track switch in abnormal position, movements exceeding limits of authority, runaway rolling stock, etc.

According to TSB, non-main-track collisions and derailments between 1995 and 1999 totalled 113 and 378, and 112 and 387 for 2000. The corresponding figures for dangerous goods were 62, 164, 48 and 150. Generally, the number of incidents of leakage of dangerous goods was 8 collisions and 9 derailments between 1995 and 1999, while 5 incidents occurred in 2000 [2].

Data on train incidents and accidents on main tracks related to improper positioning of hand-operated switches were provided by TSB for the period between 1995 and 2000 as shown in Table 5.

Table 5 Number of Rail Incidents and Accidents on Main Tracks Due to Reversed Positions of Hand-Operated Switches

| Year | Incidents | Accidents | Fatalities | Serious Injuries |
|--------------|------------------|------------------|-------------------|-------------------------|
| 1995 | 15 | 4 | 0 | 0 |
| 1996 | 8 | 2 | 0 | 0 |
| 1997 | 12 | 4 | 0 | 0 |
| 1998 | 14 | 0 | 0 | 0 |
| 1999 | 15 | 3 | 2 | 6 |
| 2000 | 17 | 3 | 0 | 5 |
| Total | 81 | 16 | 2 | 11 |

Source: Transportation Safety Board of Canada, August 2001

The data in Table 5 were for federally regulated railways and main-track lines. Data from provincial and other short-line railways are not reported to TSB. If these data were available and included, the estimates in Table 6 would be higher and would have a positive effect on the benefit-cost analysis.

Table 5 shows the average number of incidents between 1995 and 2000 to be 13.5 per year and the number of accidents 2.7 per year. Fatalities were averaged at 0.33 per year and the number of serious injuries at 1.8 per year. In addition, the data in Table 5 shows that fatalities were 2.5 percent and serious injuries 13.5 percent of the total number of incidents. The average annual growth rate of incidents was found to be 2.1 percent. RAC has estimated collision and derailment to be roughly 20 percent of incidents. The data in Table 5 relates closely to the RAC's estimate.

In the analysis, the number of incidents between 2001 and 2010 was first projected using a growth rate of 2 percent. Accidents were estimated to be 20 percent of the projected incidents. Fatalities and serious injuries were then estimated using percentage compositions. Table 6 shows the projected number of incidents and accidents.

Table 6 Projected Number of Railway Incidents and Accidents Due to Reversed Positions of Hand-Operated Switches (main track only)

| Year | Incidents | Accidents | Fatalities | Serious Injuries |
|--------------|------------------|------------------|-------------------|-------------------------|
| 2001 | 17 | 3 | 0 | 2 |
| 2002 | 18 | 4 | 0 | 2 |
| 2003 | 18 | 4 | 0 | 2 |
| 2004 | 18 | 4 | 0 | 3 |
| 2005 | 19 | 4 | 0 | 3 |
| 2006 | 19 | 4 | 0 | 3 |
| 2007 | 20 | 4 | 0 | 3 |
| 2008 | 20 | 4 | 0 | 3 |
| 2009 | 20 | 4 | 1 | 3 |
| 2010 | 21 | 4 | 1 | 3 |
| Total | 190 | 39 | 2 | 27 |

Note: If similar data were available for non-main-track collisions and derailments, the numbers in Table 6 would be larger.

4.6 Benefit-Cost Analysis

The sources of benefits are the reduction in property damage, personal injuries and fatal accidents, and savings resulting from reduced travel time. Costs are the initial technology costs and maintenance costs of the system. Envisaged benefits from reduced accident costs were separately treated for two options of technology costs, i.e., CAN\$10,000 and CAN\$15,000 per switch. Cost of maintaining the system was considered to be 10 percent of initial technology costs. Similarly, the analysis included the value of travel time. Economic parameters of net present value (NPV), internal rate of return (IRR) and benefit-cost ratio (B-CR) were calculated using QuattroPro Software. The software calculates the economic parameters direct from undiscounted cash flows.

NPV is the difference between benefits and costs discounted at the opportunity cost of capital. Opportunity costs are values in the best alternative use of capital (i.e., return on capital if used in alternative opportunities). Benefits and costs are discounted at the opportunity cost of capital, which is normally used as the discount rate in testing the viability of projects. Positive NPV makes a project viable. Discount rates in Canada range between 5 and 10 percent. The U.S. Federal Highway Administration (1994) has recommended 7 percent be used for benefit-cost analysis of federal programs and regulation impact analyses. In this study, a discount rate of 7 percent was used.

IRR is a discount rate at which discounted benefits and discounted costs become equal. IRR greater than the opportunity cost of capital makes a project viable. B-CR is the ratio of discounted benefits over discounted costs at the opportunity cost of capital. A project with a B-CR of one and above is considered to be economically viable.

Tables 7 and 8 show the results of the analysis. Alternatives I and II are options with investment costs of CAN\$10,000 and CAN\$15,000, respectively. Maintenance costs were estimated at 10 percent of investment costs. The period of analysis used was ten years, 2001-2010. Year 2000 is the initial period of investment. Costs and benefits are in thousands of Canadian dollars. It is important to note that this analysis was completed using only the data on mainline-track collisions and derailments. Although Tables 5 and 6 include historic numbers and forecast of incidents, no economic costs were assigned to this category.

Table 7 Results of Benefit-Cost Analysis Without Value of Travel Time

| Year | Alternative I (\$10,000) | | | Alternative II (\$15,000) | | |
|------|--------------------------|----------|----------------|---------------------------|----------|----------------|
| | Costs | Benefits | Net Cash Flows | Costs | Benefits | Net Cash Flows |
| 2000 | 65,000 | - | -65,000 | 97,500 | - | -97,500 |
| 2001 | 6,500 | 1,840 | -4,660 | 9,750 | 1,840 | -7,910 |
| 2002 | 6,500 | 1,880 | -4,620 | 9,750 | 1,880 | -7,870 |
| 2003 | 6,500 | 1,915 | -4,585 | 9,750 | 1,915 | -7,835 |
| 2004 | 6,500 | 1,955 | -4,545 | 9,750 | 1,955 | -7,795 |
| 2005 | 6,500 | 1,990 | -4,510 | 9,750 | 1,990 | -7,760 |
| 2006 | 6,500 | 2,030 | -4,470 | 9,750 | 2,030 | -7,720 |
| 2007 | 6,500 | 2,070 | -4,430 | 9,750 | 2,070 | -7,680 |
| 2008 | 6,500 | 2,115 | -4,385 | 9,750 | 2,115 | -7,635 |
| 2009 | 6,500 | 2,155 | -4,354 | 9,750 | 2,155 | -7,595 |
| 2010 | 6,500 | 2,200 | -4,300 | 9,750 | 2,200 | -7,550 |
| NPV | | | -90,330 | | | -142,040 |
| IRR | | | Negative | | | Negative |
| B-CR | | | 0.13 | | | 0.08 |

Note: Monetary values are in thousands of Canadian dollars.

Table 8 Results of Benefit-Cost Analysis With Value of Travel Time

| Year | Alternative I (\$10,000) | | | Alternative II (\$15,000) | | |
|------|--------------------------|-----------|----------------|---------------------------|-----------|----------------|
| | Costs | Benefits | Net Cash Flows | Costs | Benefits | Net Cash Flows |
| 2000 | 65,000 | - | -65,000 | 97,500 | - | -97,500 |
| 2001 | 6,500 | 1,424,950 | 1,418,450 | 9,750 | 1,424,950 | 1,415,200 |
| 2002 | 6,500 | 1,469,450 | 1,462,950 | 9,750 | 1,469,450 | 1,459,700 |
| 2003 | 6,500 | 1,515,345 | 1,508,845 | 9,750 | 1,515,345 | 1,505,595 |
| 2004 | 6,500 | 1,562,685 | 1,556,185 | 9,750 | 1,562,685 | 1,552,935 |
| 2005 | 6,500 | 1,611,510 | 1,605,010 | 9,750 | 1,611,510 | 1,601,760 |
| 2006 | 6,500 | 1,661,865 | 1,655,365 | 9,750 | 1,661,865 | 1,652,115 |
| 2007 | 6,500 | 1,713,800 | 1,707,300 | 9,750 | 1,713,800 | 1,704,050 |
| 2008 | 6,500 | 1,767,370 | 1,760,870 | 9,750 | 1,767,370 | 1,757,620 |
| 2009 | 6,500 | 1,822,620 | 1,816,120 | 9,750 | 1,822,620 | 1,812,870 |
| 2010 | 6,500 | 1,879,610 | 1,873,110 | 9,750 | 1,879,610 | 1,869,860 |
| NPV | | | 10,610,720 | | | 10,559,015 |
| IRR | | | 2266 | | | 1507 |
| B-CR | | | 104 | | | 69 |

Note: Monetary values are in thousands of Canadian dollars.

Evaluation of the data in Tables 7 and 8 shows that replacement of hand-operated switches with electrical devices is expensive and not justifiable, if only savings in property damages and human accidents are considered. However, if the reduction in travel time is included, the project would be economically viable. Sensitivity tests were conducted using only 10 and 5 percent of the value of travel time plus the benefits of accident reduction. Table 9 shows the results of the sensitivity analysis, indicating that the project is still considered viable with only 10 and 5 percent of the value of travel time.

As mentioned above, the accidents included in the analysis are only for main tracks and federally regulated railways. The inclusion of non-main-track lines and provincial data would increase benefits.

Table 9 Results of Sensitivity Analysis

| Alternative | NPV (\$) | | IRR (%) | | B-CR | |
|-------------|----------|---------|---------|-----|------|-----|
| | 10% | 5% | 10% | 5% | 10% | 5% |
| I | 968,450 | 439,080 | 215 | 106 | 10.4 | 5.3 |
| II | 916,790 | 387,375 | 140 | 68 | 6.9 | 3.5 |

5 CONCLUSIONS

A review was conducted to identify available technologies that could be used for providing advance information to train crews on the position of hand-operated switches on non-signalled rail lines. This included survey responses, interviews, e-mail responses and telephone conversations.

A number of suppliers produce technologies with potential application to the problem of switch position indication. The decision to implement a specific technology would be based on the potential market and the associated return on investment. The initial benefit-cost analysis conducted as part of this study along with the description of the technical features offered by each technology should assist in making a final decision on the feasibility of implementing a specific technology.

Ten technologies that appeared to have potential for application to the study objective were identified. Of these, five were considered to have the highest probability of successful application. The technologies identified ranged from a prototype under test by Canadian National Railway to individual components that could be assembled to construct a system. A number of these technologies, including the system developed by CN and the technology proposed by ARS Networks Inc., offer the same capabilities with similar components and operation characteristics.

The study results indicated that cost-effective and reliable systems could be installed to indicate the position of hand-operated switches on rail lines. The preliminary benefit-cost analysis indicates that a project to replace current hand-operated switch position indicators with electronic equipment would be expensive and not justifiable, if only cost savings in property damage and reduction in the number of injuries and fatalities are considered. However, the project should be economically viable even when only 5 or 10 percent of the value of travel time for passenger and cargo operations is included in the analysis.

Discussions with experts and railway operators indicate that they believe that sufficient technological means exist to develop suitable products and/or to implement existing technologies. The most important technical issues are that the selected system should provide a high level of reliability at the lowest cost, combined with ease of installation and operation, minimal maintenance requirements and extended durability.

The chosen technology should be highly reliable, cost-effective and easily upgraded to meet other requirements that may be imposed by future developments in the railway industry.

REFERENCES

- 1 Transportation Safety Board of Canada, *Railway Investigation Report on Derailment/Collision*, Report Number R99H0007, 2000, 16-21.
- 2 Transportation Safety Board of Canada, *Statistical Summary of Railway Occurrences* (Internet), 1999, 1-19.
- 3 Hilleary T.N, *Use of Cellular Control Channels For Low Cost Monitoring Applications*, Technical Information, LaBarge Inc, Network Technologies Group, Kansas, June 2001, 1-11.
- 4 Robak A., *The Applicability of HDM-4 to Road Projects in the Province of New Brunswick*, Senior Report, University of New Brunswick, Department of Civil Engineering, Fredericton, March 2001.

APPENDICES

APPENDIX A
Survey Questionnaires

Survey Questionnaire Prepared for Universities, University/Industry Liaison Offices and Research Centres



UNIVERSITY OF
NEW BRUNSWICK
E3B 5A3

Post Office Box 4400 / Fredericton, N.B. / Canada

Department of Civil Engineering
(506) 453-4521

Fax: (506) 453-3568
E-mail: civileng@unb.ca

March 11, 2001

Re: Study of Systems to Indicate the Position of a Hand-Operated Switch on Non-Signalled Rail Lines

The Transportation Group located at the University of New Brunswick in Fredericton, New Brunswick, Canada has been requested to complete a research study of a system capable of indicating the position of a hand-operated switch on non-signalled rail lines.

The study group at this time is conducting a survey of universities, research centres, rail line operators, equipment designers/suppliers, and other agencies with the potential to contribute to a solution to the problem.

The study team would appreciate your office bringing this request to the attention of any faculty members in your university who may be working in this or a related area.

Interested faculty members are requested to supply information on the points listed below:

1. The development of technology that can be used to detect the position of a hand-operated rail switch and transmit the status of the switch to a remote location (e.g., locomotive, traffic control centre)
2. If your research has developed a technology to address this type of problem, what kind of communication systems could be used to transmit advanced warning to train crews on the position of the switch (e.g., RF, satellite-based communication systems, videos, fibre optic)?
3. If an “at switch” power supply is required, would a solar source be acceptable?
4. Keeping in mind that a safe, low cost, reliable and maintainable resolution to this issue is being sought:
 - (a) What technology (systems architecture and function) would you propose to address the issue?

(b) If you have a usable technology, could you provide an itemized list of costs to the user, and a description of components?

(c) What level of market demand would motivate you to produce or put together a system to address this issue?

5. Are there any constraints to producing the equipment?

6. We would welcome any other comments and/or descriptive materials.

Please e-mail responses at earliest convenience to Lino García at lino@unb.ca.

Thank you for your cooperation.

Sincerely

Dr. Alemayehu Ambo
Post Doctoral Fellow
University of New Brunswick
Dept. of Civil Engineering
Transportation Group
Tel: (506) 453-31.04
Fax: (506) 453-3568

Lino O. García
Research Assistant
University of New Brunswick
Dept. of Civil Engineering
Transportation Group
Tel: (506) 453-5065
Fax: (506) 453-3568

Survey Questionnaire Prepared for Suppliers and Manufacturers



UNIVERSITY OF
NEW BRUNSWICK
5A3

Post Office Box 4400 / Fredericton, N.B. / Canada E3B

Department of Civil Engineering
(506) 453-4521

Fax: (506) 453-3568
E-mail: civileng@unb.ca

March 11, 2001

Re: Study of Systems to Indicate the Position of a Hand-Operated Switch on Non-Signalled Rail Lines

The Transportation Group located at the University of New Brunswick in Fredericton, New Brunswick, Canada has been requested to complete a research study of a system capable of indicating the position of a hand-operated switch on non-signalled rail lines.

The study group at this time is conducting a survey of rail line operators, equipment designers/suppliers, research centres, and other agencies with the potential to contribute to a solution to the problem.

We would appreciate receiving information on the following:

1. The development of technology that can be used to detect the position of a hand-operated rail switch and transmit the status of the switch to a remote location (e.g., locomotive, traffic control centre)
2. If your organization has a technology to address this type of problem, what kind of communication systems could be used to transmit advanced warning to train crews on the position of a switch (e.g., RF, satellite-based communication systems, videos, fibre optic)?
3. If an “at switch” power supply is required, would a solar power be acceptable?
4. Keeping in mind that a safe, low cost, reliable and maintainable resolution to this issue is being sought:
 - (a) What technology (systems architecture and function) would you propose to address the issue?
 - (b) If you have a usable technology, could you provide an itemized list of costs to the user, and a description on components?
 - (c) What level of market demand would motivate your organization to produce or put together a system to address this issue?

5. Are there any constraints to producing the equipment?
6. We would welcome any other comments and/or descriptive material.

Please e-mail responses at your earliest convenience to lino@unb.ca.

Thank you for your cooperation.

Sincerely

Dr. Alemayehu Ambo
Post Doctoral Fellow
University of New Brunswick
Dept. of Civil Engineering
Transportation Group
Tel: (506) 453-31.04
Fax: (506) 453-3568

Lino O. García
Research Assistant
University of New Brunswick
Dept. of Civil Engineering
Transportation Group
Tel: (506) 453-5065
Fax: (506) 453-3568

APPENDIX B

*List of Universities, University/Industry Liaison
Offices, Suppliers, Carriers, Railway Institutions
and Research Centres Contacted in North America,
Europe and Australia*

**List of Universities, University/Industry Liaison Offices, Suppliers,
Carriers, Railway Institutions and Research Centres contacted in
North America, Europe and Australia**

| ORGANIZATION | COMMENTS |
|--|---|
| Canadian Universities | |
| Dalhousie University (Canada) Contact person: Carl Breckenridge E-mail: cbreckenridge@Kilcom1.UCIS.Dal.Ca | There is relatively little expertise or interest here at Dalhousie in this research area. |
| Office of Industry Liaison / University of Western Ontario (Canada) Contact person: Doug Gill E-mail: dgill@uwo.ca | NR/D* |
| University of Toronto (Canada) Contact person: Eric J. Miller E-mail: miller@jpint.utoronto.ca | NR/D* |
| University of Manitoba (Canada) Contact person: Joanne Keselman E-mail: joanne_keselman@umanitoba.ca | NR/D* |
| The Genesis Group / Memorial University of Newfoundland (Canada) Contact person: John Guzzwell E-mail: guzzwell@genesis.mun.ca | NR/D* |
| Office of Technology Transfer / McGill University (Canada) Contact person: Alex Navarre E-mail: alex.navarre@mcgill.ca | No time to respond questionnaires or broad requests. |
| University of Windsor (Canada) Contact person: Neil Gold E-mail: ngold@uwindsor.ca | NR/D* |
| Concordia University (Canada) Contact person: Arlene Alcock E-mail: aja@vax2.concordia.ca | NR/D* |
| University of Alberta (Canada) Contact person: Roger S. Smith E-mail: roger.smith@ualberta.ca | NR/D* |

*No research or development

| ORGANIZATION | COMMENTS |
|---|-----------------|
| University of Victoria (Canada) Contact www.uvic.ca | No response |
| Carleton University (Canada) Contact person: Feridum Hamdullahpur E-mail: feridun_hamdullahpur@carleton.ca | No response |
| Lakehead University (Canada) Contact person: Mark L. Howe E-mail: mark.howe@lakeheadu.ca | No response |
| McGill University (Canada) Contact person: Pierre Bélanger E-mail: pbelange@fgsr.lan.mcgill.ca | NR/D* |
| McMaster University (Canada) Contact person: Gerehard Gerber E-mail: gerberg@mcmaster.ca | NR/D* |
| Memorial University of Newfoundland (Canada) Contact person: Chris Loomis E-mail: cwloomis@mun.ca | No response |
| Queen's University at Kingston (Canada) Contact person: Kerry Rowe E-mail: rowek@post.queensu.ca | No response |
| Royal Military College of Canada (Canada) Contact person: John Cowan E-mail: cowan-j@rmc.ca | NR/D* |
| Ryerson Polytechnic University (Canada) Contact person: Rena Mendelson E-mail: mendelso@ryerson.ca | No response |
| Simon Fraser University (Canada) Contact person: Bruce Clayman E-mail: clayman@sfu.ca | No response |
| University of Northern British Columbia (Canada) Contact person: Deborah Poff E-mail: poff@unbc.edu | No response |

*No research or development

| ORGANIZATION | COMMENTS |
|--|--|
| University of Regina (Canada) Contact person: Amit Chakma E-mail: Amit.Chakma@uregina.ca | No response |
| University of Western Ontario (Canada) Contact person: William Bridges E-mail: w6fa@its.caltech.edu | NR/D* |
| University College of Cape Breton (Canada) Contact person: Robert Campbell E-mail: rcampbel@uccb.ns.ca | NR/D* |
| University of British Columbia (Canada) Contact person: Indira Samarasekera E-mail: vpr@interchange.ubc.ca | No response |
| University of Calgary (Canada) Contact person: Keith Archer E-mail: kaarcher@ucalgary.ca | NR/D* |
| University of Guelph (Canada) Contact person: Larry Milligan E-mail: milligan@exec.admin.uoguelph.ca | No response |
| University of New Brunswick (Canada) Contact person: Bruce Colpitts E-mail: colpitts@unb.ca | Two approaches can be used. RF signals can be transmitted from the switch directly to the train. Other approach can use satellite communications to receive signals from the switches. Information is transmitted to a dispatch centre and then to the locomotive. No signal lights would have to be used. |
| University of Ottawa (Canada) Contact person: Howard Alper E-mail: halper@uottawa.ca | No response |
| University of Saskatchewan (Canada) Contact person: Michael Corcoran E-mail: michael.corcoran@usask.ca | No response |

*No research or development

| ORGANIZATION | COMMENTS |
|--|-----------------|
| University/Industry Liaison Offices | |
| University Technologies International / University of Calgary (Canada) Contact persons: Oleh S. Hnatiuk Hugh R. Jones E-mail: hnatiuk@uti.ca jonesh@uti.ca | No response |
| Technology Transfer Office / University of Toronto (Canada) Contact person: Peter Munsche E-mail: peter.munsche@utoronto.ca | NR/D* |
| Technology Transfer and Licensing Office / University of Waterloo (Canada) Contact person: G.G.H. Gray E-mail: gghgray@uwaterloo.ca | No response |
| Bureau de liaison entreprises- Université (BLEU) / University of Sherbrooke (Canada) Contact persons: Michèle Desrochers Suzanne Chamberland E-mail: michele.desrochers@courrier.usherb.ca suzanne.chamberland@courrier.usherb.ca | No response |
| University-Industry Liaison Office / University of British Columbia (Canada) Contact person: Angus Livingstone E-mail: aal@uilo.ubc.ca | No response |
| PARTEQ Innovations / Queen's University (Canada) Contact person: John P. Molloy E-mail: molloyj@post.queensu.ca | No response |
| Office of Research Contracts and Intellectual Property / McMaster University (Canada) Contact person: Marcel Mongeon E-mail: marcelm@macmaster.ca | No response |

*No research or development

| ORGANIZATION | COMMENTS |
|---|--|
| Bureau de liaison entreprises- Université (BLEU) / University of Montreal (Canada) Contact persons: Michael Rivest Jean Yvon Timothy E-mail: michael.rivest@umontreal.ca jean.yvon.timothy@umontreal.ca | No response |
| University-Industry Liaison Office / Simon Fraser University (Canada) Contact person: Michael Volker E-mail: mvolker@sfu.ca | No response |
| University of Saskatchewan Technologies Inc. (Canada) Contact person: Branko Peterman E-mail: Peterman@sask.usask.ca | No response |
| NU_TECH (Nova Scotia Universities Technology Inc.) (Canada) Contact person: C. Gordon Owen E-mail: gordon.owen@dal.ca | NR/D* |
| Centre for Research and Development Services / University of New Brunswick (Canada) Contact person: David Foord E-mail: foord@unb.ca | Comments on Dr. Bruce Colpitts's technology (local transmitter or a GPS-based system). |
| Organizations and Suppliers/Manufacturers | |
| Canadian National Railway Contacts: various | Testing a system with positive results in Uxbridge, Toronto (see Appendix C). |
| Canadian Pacific Railway Contact person: Robert L. Nash Tel: (403) 319-7799 Fax: (403) 205-9008 E-mail: bob_nash@cpr.ca | System will likely have to be implemented. On-board locomotive component requirements should be avoided because of interchanging of units between railways. |
| Hovey Industries Ltd. (Canada) Contact person: Edie Everett E-mail: edie@hovey.ca | NR/D*. Produces products for clearing switches of ice and snow. |

*No research or development

| ORGANIZATION | COMMENTS |
|---|---|
| Minnesota DOT (USA) Contact person: Steve Bahler E-mail: steve.bahler@dot.state.mn.us | Most effective solution would be a GPS location system. Installation of a switch position sensor and use of a short-range radio transmitter. |
| Teleste Surveillance Networks (USA) Contact person: Jim Connors E-mail: jim.connors@teleste.com | NR/D* Provides video surveillance systems. |
| VAE Nortrak (Canada) Contact Person: Franz Sodia E-mail: franz.sodia@vae.co.at | Initial contact was made but no further information was obtained from this company. |
| Union Switch & Signal (USA, Canada) Contact person: Smith, L. Kean E-mail: lksmith@switch.com | NR/D* No systems available. More important concern is potential return of investments. Some competitors are developing PTC Systems that may be employing remote indication. |
| Jasmin PLC (United Kingdom) Contact person: Keith Salway E-mail: Keith.Salway@jasmin.plc.uk | Presented a proposal of a system for switch monitoring (see Appendix C for details). |
| Schaffler & Associates Pty Ltd (USA) Contact person: Bernard Schaffler E-mail: BLS@bigpond.com | Not involved. Make auxiliary inverters and battery chargers for trains. |
| Honeywell Regelsysteme GmbH (Germany) E-mail: st.vertrieb@honeywell.com | NR/D* |
| Centre for Transportation Studies / University of Minnesota (USA) Contact person: Robert C. Johns E-mail: johns003@data3.ndis.umn.edu | NR/D* |
| International Fiber Systems (USA) Contact: www.ifs.com/its.htm | Nothing related to rail switches. |
| Carmanah Railway Lights (Canada) Contact: www.railwaylights.com | Produces signal lights that provide high reliability at low cost (see Appendix C for details). Technology may be applicable if some modifications are introduced by the manufacturer. |

*No research or development

| ORGANIZATION | COMMENTS |
|---|--|
| Foster Technologies (Canada) Contact person: Adam Street E-mail: astreet@lbfosterco.com | Produces a state-of-the-art technology to control switch position (see Appendix C for details). |
| SNC-Lavalin (Canada) Contact: Transport Division E-mail: vtransport@snc-lavalin.com | Not involved. Recommended other companies including Alcatel, Alstom, Safetrans, Union Switch & Signals, Adtranz and Siemens. |
| CIMAT Power Systems Inc. (Canada) Contact person: Ray Lalonde E-mail: ray@cimat.com | Provides solar autonomous beacon system and power supply for signal lights (see Appendix C for details). |
| ARS Networks Inc. (USA) Contact person: Sydney Harland E-mail: shardland@arsnetworks.com | Provides a technology based on transducers and RF communication, which could be applicable to switch position indication. |
| Siemens ATEA (USA) Contact person: Martin Gombosi E-mail: martin03@aol.com | Some available technologies including a local contact at the hand switch and RF transmission. |
| COGIFER S.A (France, USA) Contact: www.cogifer.com E-mail: cogifer@cogifer.com | NR/D* |
| GE Harris Harmon Railway Technology (Canada) Contact person: Sue McConville Tel: (780) 988-2971 Fax: (780) 432-3002 E-mail: sue.macconville@gehh.ge.com | Provides products that could be adapted (Vital Harmon Logic Controller, Harmon Switch Controller, etc.). |
| Filnor Inc. (USA) Contact: www.filnor.com E-mail: filnor@filnor.com | NR/D* |
| NDT Technologies Inc. (Canada) Contact person: Kelly Flewwelling E-mail: info@ndt.ca | NR/D* |
| Image Sensing Systems Inc. (USA) Contact: www.imagesensing.com | NR/D* Video detection products and services. |
| Wireless Technology Inc. (USA) Contact: www.wirelesstech.com E-mail: wireless@wirelesstech.com | Provides video and camera data control communication systems. |

*No research or development

| ORGANIZATION | COMMENTS |
|---|--|
| CONTEC GMBH (Germany) Contact: www.contec-group.com E-mail: info@conctec-group.com Contact in Canada: H.J. Skelton Ltd. Contact persons: Geoff Richey Peter Fraser E-mail: skelton@skelton-metals.com | No response |
| Siliani Harmon (Italy) (Subsidiary of Harmon Industries) | No response |
| Safetran Systems (USA) Contact: www.safetran.com | No response after follow-up contacts. |
| ESRI (USA) Contact person: Rosa Cisneros E-mail: giswebmaster@gis.com | Provides GIS products with railway applications (i.e., Arcinfo 8). |
| Alstom Transport Signalling (Canada) Contact person: Luigi Sain E-mail: luigi.sain@transport.alstom.com | Nothing related to switch points signalling. |
| Microwave Sensor Inc. (USA) Contact person: Robert C. Hunter E-mail: bhunter@microwavesensors.com | NR/D* |
| Alcatel Canada Inc (Canada) Contact person: Lou Mitrovich Tel.: 1-905-873-6300 Fax: 1-905-877-3675 | No response |
| Adtranz Signal, Daimler Chrysler Rail Systems Signal (Sweden) Contact person: Jerry Lindbergh E-mail: jerry.lindbergh@se.adtranz.com | NR/D* |
| IEC - Holden Inc. (Canada) Contact person: Bruno Pietrobon | NR/D* |
| A.M. Signal Systems Ltd. (Canada) Contact person: Dan Fargiorgio E-mail: genoff@advancerailway.com | No response |

*No research or development

| ORGANIZATION | COMMENTS |
|--|--|
| Railway Gazette International (United Kingdom) Contact person: Christopher M. Jackson E-mail: Chris.Jackson@rbi.co.uk. | Not aware of any specific manufacturer of a related technology. In Great Britain there are some locally powered signal lights to detect the position of hydraulically sprung switch points, but they are only used at very low speeds. |
| Gardner Systems (USA) Contact: www.gardnersys.com | Provides communication systems that could be used; however, they may be expensive. |
| Intermec European (France) Tel.: 33 1 30 15 25 80 Fax: 33 1 30 15 25 85 Contact: www.intermec.com | NR/D* |
| Westinghouse Signals (United Kingdom) Tel.: 44 1249 441441 Fax: 44 1249 652322 E-mail: marketing.dept@westsig.co.uk | No response after follow-up contacts. |
| Station Equipment and Fare Collection / Mars Electronics International - Payment Systems (USA) Contact: www.railway-technology.com /contractors/noise/ | NR/D* |
| Track and Rail Maintenance and Safety Equipment Visual Inspection Systems for Track Maintenance (USA) Contact: www.railway-technology.com /contractors/track/ | NR/D* |
| Airchime Manufacturing Co. Ltd (Canada) Contact person: D.W. Challenger E-mail: info@airchime.bc.ca | No response |
| Altex Extrusion Inc. (Canada) Contact person: Real Bouthillette E-mail: info@altex-ext.com | No response |
| Jaychris Indus-Rail Supply Inc. (Canada) E-mail: jaychris@total.net | No response |

*No research or development

| ORGANIZATION | COMMENTS |
|--|--------------------------|
| Logisource Inc. (Canada) Contact person: Daniel Leavitt E-mail: logisource@sympatico.ca | No response |
| Canac Inc. (Canada) Tel.: (514) 399-5741 Fax: (514) 399-8298 E-mail: pubmail@canac.com | Waiting for information. |
| Caradon Indalex (Canada) Contact person: Terry Wagner E-mail: terry-wagner@caradon.com | No response |
| CPCS Transcom Limited (Canada) E-mail: ottawa@cpcstrans.com | No response |
| D.W. Gill Supply Company Ltd. (Canada) Contact person: Dave Gill E-mail: dave@gillgroup.com | No response |
| Teklogix International Inc. (Canada) Contact person: Kyle Day E-mail: info@teklogix.com | NR/D* |
| Andrew Corporation (USA) E-mail: Jan.gehrman@andrew.com | NR/D* |
| Intermec Technologies (USA) Fax: 1-800-363-4841 | NR/D* |
| ABC-NACO (USA) Contact person: R.Paul Kneeshaw E-mail: kneeshawp@abc.naco.com | No response |
| Elin EBG Traction GmbH - Railway Traction Equipment Electrification, Traction and Power Supply (Austria) Contact: www.railway-technology.com /contractors/electrification/ | NR/D* |
| Stork Rmo (Netherlands) Contact person: R.J.A. Kortink E-mail: gv@rmo.storkgroup.com | NR/D* |

*No research or development

| ORGANIZATION | COMMENTS |
|---|---|
| <p>Engineering, Test and Testing Equipment Train Wheel Inspection and Rail Inspection Systems / Scanmaster Systems (IRT) Ltd (Israel) Contact: www.railway-technology.com /contractors/freight/</p> | <p>NR/D*</p> |
| <p>Boge GmbH - Vibration Control Components Noise and Vibration Insulation Products (Germany) Contact: www.railway-technology.com /contractors/noise/</p> | <p>NR/D*</p> |
| <p>VAE AG (Austria) Contact: www.vae-ag.com Tel.: 43 1 531 180 Fax: 43 1 531 18 222 E-mail: marketing@vae.co.at</p> | <p>NR/D*</p> |
| <p>Kapsch AG - Railway Communications Systems (Austria) Contact: www.kapsch.net Tel.: 43 1 811 11 4221 Fax: 43 1 811 11 8752 E-mail: kapsch_ccn.at@kapsch.net</p> | <p>Produces communication systems but does not seem to be heavily involved in rail switch signalling.</p> |
| <p>LaBarge Inc. (USA) Contact person: Vince Burget Tel.: (816) 246-0965 E-mail: vburget@scadanet.net</p> | <p>Supplies a wireless remote monitoring device that can monitor the switch position. An alarm message can be sent from a field unit cellular RTU to a mobile pager using Web Messaging Service (see Appendix C for details).</p> |
| <p>North American Signal, Inc. (USA) Contact person: Tom Trovato Tel.: (904) 287-6873 E-mail: tom.trovato@nasignal.com</p> | <p>Specializes in transportation control systems with emphasis on wireless data transmission. Supplies a product that can enunciate voice or transmit telemetry tones in a typical wayside environment. A complete ready-to install system can be provided upon request (see Appendix C for details).</p> |

*No research or development

| ORGANIZATION | COMMENTS |
|--|----------|
| Other Universities and Research Centres (Europe and Australia) | |
| Department of Electrical and Electronic Engineering / University of Bristol (United Kingdom) Contact person: Mr. A.K. Arumugam E-mail: Arun.Arumugan@bristol.ac.uk | NR/D* |
| Department of Electronics and Electrical Engineering / University of Edinburgh (United Kingdom) Contact person: Peter M. Grant E-mail: P.M.Grant@ee.ed.ac.uk | NR/D* |
| École Centrale (France) Contact person: Francis Van Den Bussche E-mail: direction.recherche@ads.ecp.fr | NR/D* |
| Engineering & Physical Systems, School of Advanced Technologies & Processes, Centre of Railway Engineering / Central Queensland University (Australia) Contact person: Mark Steedman E-mail: m.steedman@cqu.edu.au | NR/D* |
| Department of Civil Engineering, The International Development Technology Centre / University of Melbourne (Australia) Contact person: Hector Malano E-mail: H.Malano@civag.unimelb.edu.au | NR/D* |
| School of Electrical Engineering and Telecommunications / University of South Wales (Australia) Contact person: Banko Celler E-mail: b.celler@unsw.edu.au | NR/D* |

*No research or development

| ORGANIZATION | COMMENTS |
|---|--|
| Department of Electrical and Electronic Engineering / Adelaide University (Australia) Contact person: Michael Liebelt E-mail: mike@eleceng.adelaide.edu.au | NR/D* |
| Department of Engineering / University of Aberdeen (United Kingdom) E-mail: wwwdoc@muscae.eng.abdn.ac.uk | No response |
| Department of Electronic and Electrical Engineering / University of Strathclyde (United Kingdom) Contact person: John Dunlop Tel.: 44 0 141 548 2384 Fax: 44 0 141 552 4968 E-mail: j.dunlop@eee.strath.ac.uk | Developed a video system that transmits between train and trackside; also several technological innovations, including mobile base stations. |
| Curtin University of Technology Research & Development (Australia) Contact person: Paul Rossiter E-mail: P.Rossiter@curing.edu.au | NR/D* |
| Faculty of Technology and Industrial Education / Northern Territory University (Australia) Contact person: Anjan Kundu E-mail: Anjan.kundu@ntu.edu.au | No response |
| Department of Mechanical Engineering / University of Queensland (Australia) Contact person: Shantha Liyanage E-mail: admin@techman.ug.edu.au | No response |
| Collaborative Research Centre for Satellite Systems, Electrical and Electronic Systems Engineering / Queensland University of Technology (Australia) Contact person: Neil Bergmann E-mail: n.bergmann@qut.edu.au | NR/D* |

*No research or development

| ORGANIZATION | COMMENTS |
|---|-----------------|
| Universities and Research Centres in the United States | |
| Purdue University (USA) Contact person: Gary E. Isom Tel.: (765) 494-6209 E-mail: geisom@purdue.edu | No response |
| Department of Electrical and Computer Engineering / Michigan State University (USA) E-mail: ECE_Mailbox@egr.msu.edu | No response |
| Centre for Advanced Infrastructure Transportation / Rutgers State University (USA) Contact person: Kaan Ozbay Tel.: (732) 445-2792 Fax: (732) 445-0577 | NR/D* |
| Department of Electrical Engineering / Stanford University (USA) Contact person: Andrea Goldsmith Tel.: (650) 725-6932 Fax: (650) 723-9251 E-mail: andrea@ee.stanford.edu | No response |
| California Institute of Technology (USA) Contact person: William B. Bridges Tel.: (626) 395-4809 E-mail: w6fa@caltech.edu | Not involved |
| Carnegie Mellon University (USA) Contact person: Duane A. Adams E-mail: adams@cmu.edu | No response |
| Department of Electrical and Computer Engineering / Iowa State University (USA) Tel.: (515) 294-2663 Fax: (515) 294-3637 E-mail: ece@ee.iastate.edu | No response |

*No research or development

| ORGANIZATION | COMMENTS |
|--|--|
| Massachusetts Institute of Technology (USA) Contact person: Alan Chachich E-mail: chachich@mit.edu | Provided information on various potential solutions to the problem (see Appendix C for details). |
| Worcester Polytechnic Institute (USA) Contact person: William Michalson E-mail: wrm@ece.wpi.edu | Provided relevant comments as well as information on a GPS technology developed and tested at the Worcester Institute. |
| Centre for Microcomputers in Transportation, Transportation Research Centre / University of Florida (USA) Contact person: Janet D. Degner Tel.: (352) 392-0378 (ext. 227) Fax: (352) 392-3224 E-mail: jdegn@ce.ufl.edu | NR/D* |
| Communication and Sensing Laboratory, Department of Electrical and Computer Engineering / University of Illinois at Chicago (USA) Contact person: Rashid Ansari Tel.: (312) 996-5489 Fax: (312) 413-0024 E-mail: ansari@eecs.uic.edu | No response |
| Communications and Signal Processing, Engineering and Applied Science / University of Colorado (USA) Contact person: Mark A Wickert E-mail: wickert@eas.uccs.edu | No response |
| Office of Engineering Research / University of Florida (USA) Tel.: (352) 392-9447 Fax: (352) 846-1371 E-mail: oer@eng.ufl.edu | No response |
| College of Science, Mathematics, and Technology / University of Texas at Brownsville (USA) Contact person: T. Jay Phillips E-mail: tjayp@utb1.utb.edu | NR/D* |

*No research or development

| ORGANIZATION | COMMENTS |
|--|-----------------|
| Information and Telecommunication Technology Centre / University of Kansas (USA) Contact person: Victor Frost Tel.: (785) 864-4833 Fax: (785) 864-0387 E-mail: frost@eecs.ukans.edu | No response |
| Centre for Transportation Studies / University of Minnesota (USA) Contact person: Robert C. Johns Tel.: (612) 625-9376 E-mail: johns003@cts.umn.edu | NR/D* |
| University of Pittsburgh (USA) Contact person: George E. Klinzing Tel.: (412) 624-0784 E-mail: klinzing@engrng.pitt.edu | No response |
| University of Virginia (USA) Contact person: Richard Miksad Tel.: (804) 924-3593 Fax: (804) 924-3555 | No response |
| University of Wisconsin (USA) Contact person: Keith Knapp E-mail: knapp@epd.engr.wisc.edu | NR/D* |
| Telecommunications Research Group, Department of Electrical Engineering / University of Texas at Arlington (USA) Contact person: Saibun Tjuatja Tel.: (817) 272-3974 E-mail: tjuatja@uta.edu | NR/D* |
| Affiliated Laboratory in Rail Research Program, Texas Transportation Institute, Association of American Railroads / Rail Research Centre (USA) Contact person: Stephen S. Roop Tel.: (979) 845-5817 Fax: (979) 862-2708 E-mail: s-roop@tamu.edu | No response |

*No research or development

APPENDIX C
*Technical Material Obtained
from the Literature Review*

**Technical Material Obtained from the Literature Review
(Survey Responses, E-mail, Fax Telephone
Conversations, and Site Visits)**

This Appendix includes all technical information on the most relevant technologies identified. Some of the materials were obtained from the web sites of suppliers, manufacturers, and organizations. Some were supplied by the individuals contacted. Technical information, product specifications, proposals, and internet printouts are presented, most as originally presented.

TECHNOLOGY: Autonomous Beacon System

SUPPLIER: CIMAT Power Systems

COUNTRY: Canada

ABS *Autonomous Beacon System*

With the increasing efficiency of modern electronic components, combined with recent improvements in renewable energy, it is now possible to have a choice when planning highway signal/hazard indicator sites. In the past, civil engineers and planners had to include costly cable runs to these sites to accommodate the beacon's power requirements. Now an alternative is available that runs completely autonomous of the power grid, thus allowing planners greater freedom in placement of hazard lighting and signals. System power is 12 volts DC which offers a much safer work environment for maintenance staff.

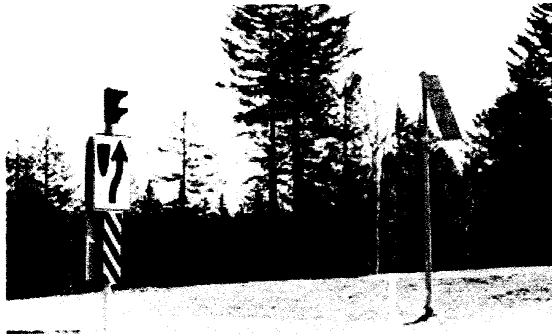

System Components

- Long-life (10-15 years) LED light assembly
- Long-life (approx. 20 years) solar panels
- Solid state electronics with lighting and surge protection
- Long-life, freeze-tolerant, deep cycle batteries
- Battery enclosure (ground or pole mount)
- Cabling or component interconnects

System Applications

- School crossings
- Road hazard warning
- Railway crossing
- Navigational hazard warning
- Intersection hazard warning
- Construction and mining hazard warning

System Features:

- Autonomous power supply
- Five day battery autonomy from solar panels
- Long-life, low-power LED beacon assemblies
- Industrial grade electronic power components
- Freeze-tolerant, deep cycle batteries
- Lightning and surge protection standard
- Optional on-site data-logger
- All components are solid state
- Minimal infrastructure requirements
- Simple installation and maintenance
- Absolute minimum maintenance requirements

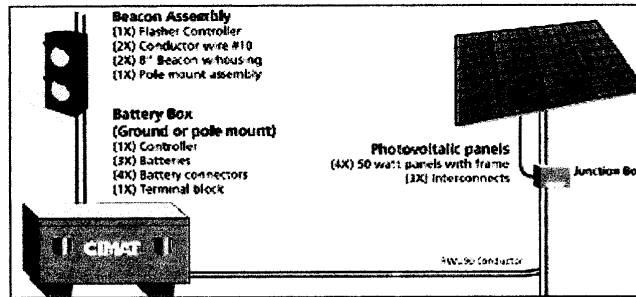

Return to Cimac [Homepage](#).

© 1998, Cimac Power Systems Inc. All Rights Reserved. info@cimat.com
Designed and Produced by [Griffintown Media Inc.](#)

Send comments to: webmaster@cimat.com

TECHNOLOGY: NAS 2001 DTMF Controller

SUPPLIER: North American Signal Inc.

COUNTRY: United States

North American Signal, Inc.

Supervisory Control and Data Acquisition Systems

North American Signal

NAS 2001 DTMF Controller

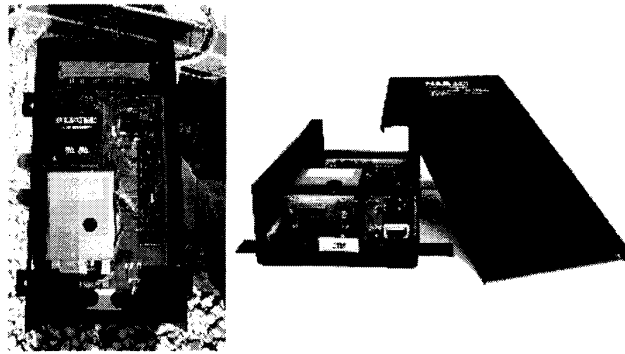

The 2001 DTMF Controller is an integral part of North American Signal's family of products. It's used for wireless Supervisory Control and Data Acquisition (SCADA) applications.

Using 2-way, wireless DTMF tone telemetry, this product provides an economical solution for controlling and monitoring your facilities without the costly build out of infrastructure to access the location. Equipped with a 5 watt UHF/VHF radio transceiver operating on your licensed frequency provides security and range not available with products that operate in the unlicensed band. With range up to 15 miles from fixed base sites the product can be controlled from the ground with a standard 2 way portable radio or configured with a fixed base control facility to operate multiple sites.

The unit comes equipped with customer configured "voice annunciation features" allowing receipt of over the air command confirmation on your 2 way radio or base equipment. Equip the base with a TELCO line interface unit and control and monitor your facilities by using the touch pad on your telephone.

With 4 Optical Isolated Inputs and 2 independent Relay Controlled Outputs the DTMF Controller provides the capability to monitor and control numerous devices at your facility. Programmable time out features allow automatic output reset. Designed with flexibility and simplicity in mind the unit can be configured in minutes with a portable radio or with the aid of PC.

Equipped standard with our low profile chassis the device will fit anywhere you can find space and can operate on either AC or DC power. The onboard DC-DC Converter provides complete battery isolation for isolated ground battery plants. Have a custom application, that is not a problem for the staff at North American

Signal, we will find a way to adapt the equipment to meet your requirements.

Applications:

Transportation:

- ◆ Key Up—Key Down Highway Grade Crossing Equipment
- ◆ Remote Control- Indication Wayside Switches ,Yard Switches
- ◆ Defect Detection
- ◆ Remote Message or Alarm Annunciation
- ◆ Auto Dialer for Maintenance Personnel
- ◆ Mobile Base Station Control

Utilities:

- ◆ SCADA System Interface
- ◆ Lift Station Monitor/Controller
- ◆ Irrigation Control
- ◆ Traffic Device Monitor
- ◆ Remote Security Monitoring

Specifications:

NAS 2001 DTMF Controller

Physical:

Chassis: 11" L X 7"W X 2" D
Environment: -20 to +70 Degrees C
Slots: Single Card slot 18 pin Connector

Radio: 5 Watt Programmable Synthesized UHF/VHF

Inputs: 4 Isolated Digital Inputs 8-40V DC 3000 volt isolation

Outputs: 2 Independent Relay Contact Rating 2 Amps @30VDC 1 Amp @ 125VAC

Power: DC-DC Converter Operating Voltage 9-36V DC, Isolated Ground

Serial Ports: DB9 Serial Female on DTMF Card DB 15 Serial Radio Transceiver

Terminals: WAGO 18 way plug in connector

Wire Size: 14 AWG—22AWG

TECHNOLOGY: Switch Point Protection System

SUPPLIER: ARS Networks Inc.

COUNTRY: United States

ARS Networks Inc.

SWITCH POINT PROTECTION PROPOSAL

The layout of the ARS Networks system shown on the attached schematic is simple and easy to install.

Components

Transducers – two transducers are mounted on the switch point throw rods to indicate position of switch point either open or closed. The transducers are hard wired to a node processor mounted on a pole at trackside.

Node Processor – this is a microprocessor that receives the transducer signals and converts the signal to indication light commands. The node processor design and specifications are exclusive to ARS Networks.

Lights – the system can support one-, two-, or three-light design, depending on client and location requirements. Where sightlines are a problem, a minimum of two lights will be required – one in each direction away from the switch point.

Spread Spectrum Radio – required in the multi-light design to relay switch point indication to remote lights.

Description of Function

The node processor continuously checks the transducers for their indication – switch point location. It takes this information and converts it to a light indication command. In the design with more than one light, this command is relayed by spread spectrum radio to the remote light locations.

Cost of System (minimum order of 10 systems; cost does not include installation)

One-Light System

- One bi-directional light at the switch point location at trackside **US\$10,000**

Three-Light System

- One bi-directional light at switch point location and two remote lights at trackside **US\$25,000**

Options

Solar Panels – solar panel and battery backup can be provided at additional cost. The basic system assumes that power is available at trackside.

Fail-Safe Operation

The simplest way to establish fail-safe operation is to have the lights off as an indication that the switch point position is undetermined or compromised. If the power source fails, the lights will be off, giving the most restrictive indication, which is “be prepared to stop at the switch point location”.

ARS Networks

SWITCH PROTECTION PROTECTION LAYOUT

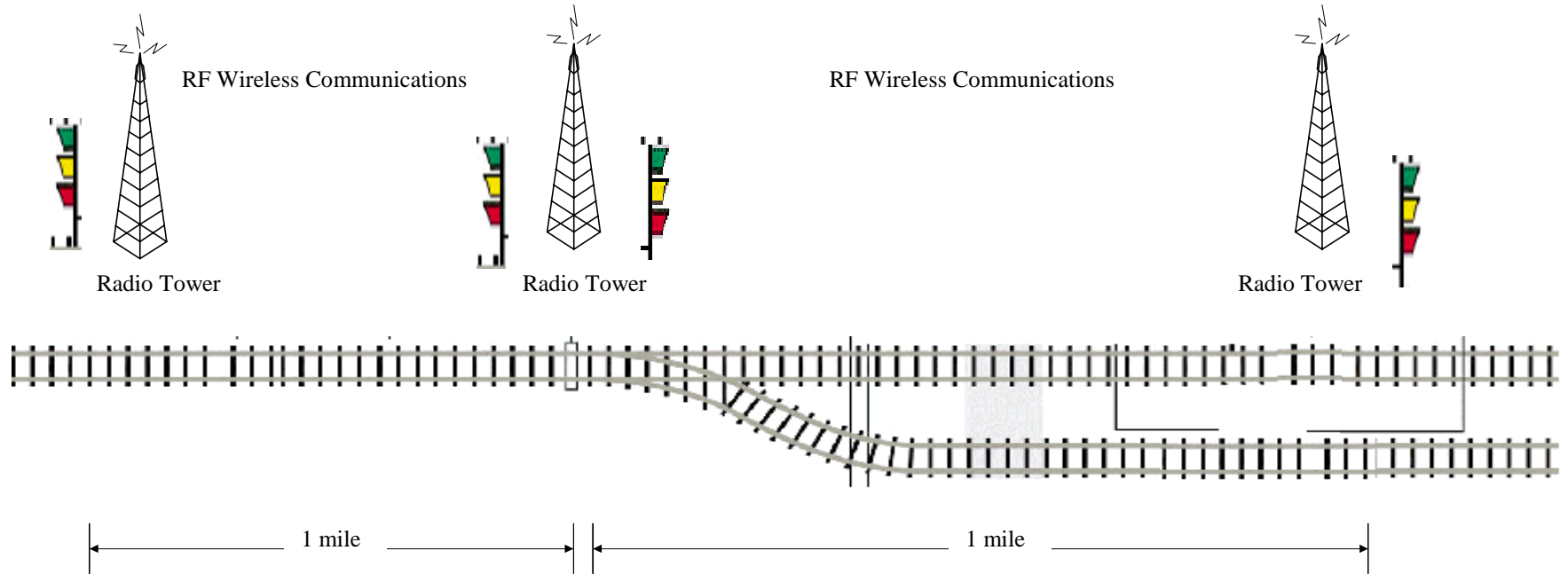

**TECHNOLOGY: Switch Point Protection System
(SPPS)**

SUPPLIER: Foster Technologies Inc.

COUNTRY: Canada

Systems

Key to Symbols

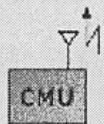

Communication Unit with Spread Spectrum Radio



Wheel Counter Unit



Zone Protection Unit



Wheel Counter Sensor Head



Sensor Cable



ISO - LAN Cable



ZPU I/O Cable

Above are the main components used to construct various systems and networks. The detailed technical specifications of each can be found on the relevant products page, or by clicking on the buttons themselves. Further standard units will be introduced over the next year to expand the capability and diversity of systems that can be created.

The following pages set out some of the systems that can be configured using Foster Technologies building blocks (UNITS). Many more potential configurations are possible, please call us to discuss your requirements or use the enquiries page.

Switch Point Protection System (SPPS)

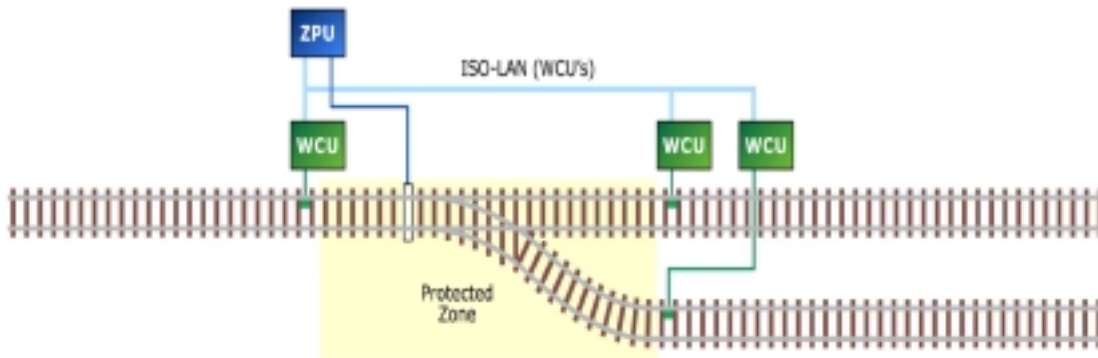

This is a suitable application for yard switches where the user wishes to prevent a switch being thrown when occupied by rail equipment. The ZPU polls the WCUs every 50 ms. When a train is detected entering the zone (noted as a positive wheel count), the transformer coupled output is turned off to prevent the switch from being operated. As the train leaves the zone (noted as a negative wheel count), when the net wheel count reaches zero, the output is turned back on. Autoline is available for trains entering the normal or reverse trailing end of the switch; another two outputs are configured for this use. Configuration of the system is undertaken by entering the WCU addresses using the ZPU buttons and display. Full details of the installation, operation and maintenance (IO&M) are available in the IOM manual. Up to 8 WCUs may be used on one ZPU to cover even the most complex track layout.

SYSTEM COMPONENTS

1. Wheel Counter Unit (WCU)

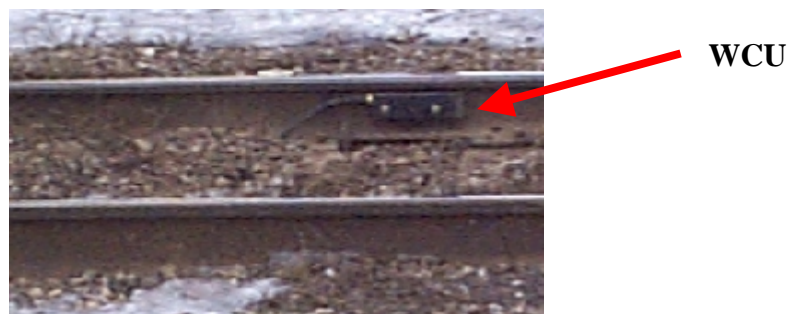

The WCU is a reliable and proven cost-effective train detection system that may be used as an alternative or to supplement track circuits. Each wheel counter system can be configured to provide the following: speed (0 - 50 mph), axle count, train direction, off-rail detection and anti sabotage. The WCU will alert the user if it is no longer able to operate safely.

The wheel counter system can be used in a variety of different applications that have traditionally used track circuits for train detection:

- Block Control
- Railway Crossing and Pre-emption
- Switch Point Protection

It can also be used in Hump Yards and for Supervisory Speed Control Systems.

2. ZONE PROTECTION UNIT (ZPU)

The ZPU is a user-configurable, cost-effective and versatile product that can be used in a variety of different applications. The “protected zone” can include switches, signal block sections or railroad crossing islands. With the ability to communicate with up to 8 Wheel Counter Units (WCU), the ZPU can protect multiple back-to-back or independent zones, depending on user requirements. Designed as a low-power unit, the ZPU can be solar powered.



ZONE PROTECTION UNIT (ZPU)

The ZPU has a maximum of 4 transformer-isolated outputs that can be used to drive existing railroad relays and/or trackside devices in the user-desired configuration. It can also be configured to deliver pulsed outputs for applications such as switch autoline capability. The inputs can be configured to read and record switch position, zone occupancies and troubleshooting/health information.

The ZPU can be used in a variety of different applications in conjunction with WCUs:

- Check in Check Out Applications
- Railway Crossing and Pre-emption
- Switch Point & Crossover Protection
- Fixed Block Control

By combining the ZPU with a Communications Unit (CMU), remote WCUs can be added where the use of buried cables is not appropriate

3. COMMUNICATIONS UNIT (CMU)

The CMU provides the means to connect network systems together to create larger network systems, and provides an access portal for external systems. For larger Wide Area Network (WAN) applications, the CMU can provide a bridge between wireless and wire mediums.

The CMU is the “junior” network entry. It has 2 serial ports and is capable of operating between 19.2k and 76.4k baud with ISO-LAN RS485 and isolation hardware. Its major physical functions include the following:

- ISO LAN to ISO LAN – Linking multiple ZPU applications, allowing them to share information;
- ISO LAN to Data Radio (Serial) – Bridging mediums to cover distances via radio;
- Acting as either a slave or as a secondary master on the ISO LAN (never primary master);
- Message Routing – Determining whether packet destination can be located via one of the ports;
- Message Buffering such that recipient confirms their arrival;
- Error Recovery – Confirmation message logic, CRC, timeout, failure detection, and retry;
- Statistics – Run time statistics logged for performance analysis;
- Configuration – CMU address and the routing table data base.

The CMU, combined with the other core FT products can be used in numerous system and network applications.

Technical Description

Unit

ZONE PROTECTION UNIT (ZPU)



WCU's supported by ZPU 8

Inputs: 4 opto isolated inputs
 Outputs: 4 Secure 12V
 Voltage: 9V min, 12V nom, 15V max. Maximum 3% ripple
 Power requirements 100 mA
 Overvoltage protection: 2kV, 1 ms
 Temperature: -40C to +85C
 Humidity: 0 to 95% (condensing and non condensing)
 Vibration: AREMA Environmental Requirements 11.5.1 - Class C
 Height 8.81"
 Width 157mm
 Length 279mm
 Weight

Assemblies

ZPU-PCK

The packaging requirements can be altered to suit the individual's needs. The codes are the same as those on the system sheet tabs.

AM

A power supply assembly is required for battery and solar panel operations

PH

Connector types at the ZPU

WAGO

AAR

Anema 4 Type Enclosure for outside locations and Class B type protection

Height 15.5"
 Width 13.38"
 Length 7.69"
 Weight

The Power Supply Assembly provides two outputs that can be configured as either 250 mA, 830mA or a combination of both and is dependant upon the amount of WCUs installed with each ZPU

WAGO Connectors used throughout

AAR Terminals

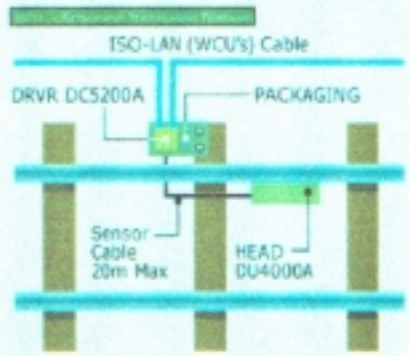
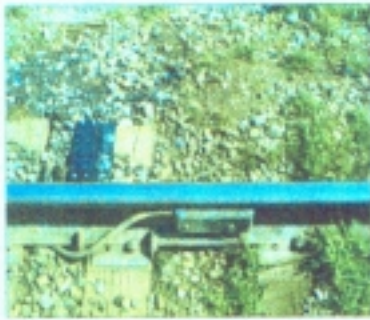

Driver Cable
The cable from the DU4000 fits into this side of the driver assembly. The colour codes are noted under the cables section of this page.

ISO-LAN Cables
The cables form the ISO-LAN fit into this side of the

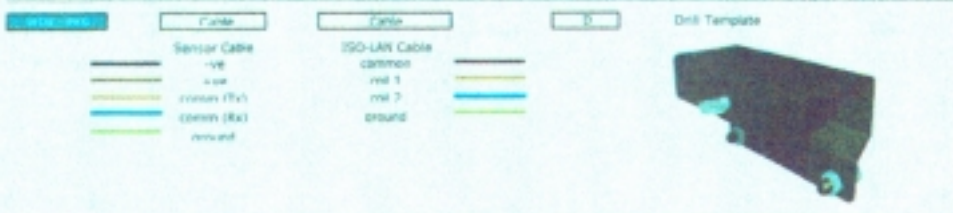
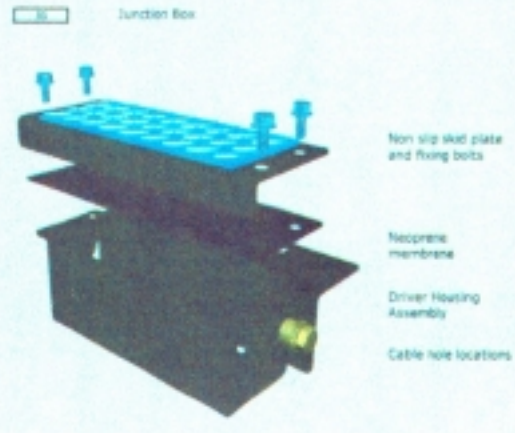
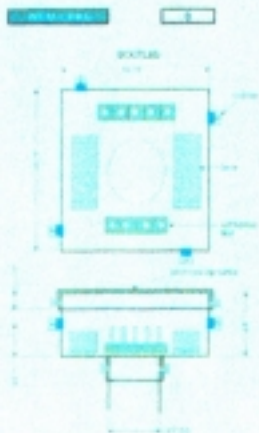

Technical Description

Unit:

WHEEL COUNTING UNIT (WCU)



Cable length to ZPU < 3 km (10,000 feet)
 Speed range: 0 - 80 km/h (0-50 mph)
 Outputs: ISO-LAN, digital and analogue
 Train wheel present: Sensor clear:
 Analogue 1.8 V ± 10% 3V ± 10%
 Digital User programmable User programmable
 Sensor voltage: 9V min, 12V nom, 15V max
 Power requirements: 35 mA
 Overvoltage protection: 2kV, 1 ms
 Temperature: -40C to +85C
 Humidity: 0 to 95% (condensing and non condensing)
 Vibration: 1000-2000Hz 20g at 30 minutes, (DSC 8 AREMA 11.5.1 Class A - Sensor)

Assemblies:

SH-0000

Sensor Head containing 2 1/2" shaped coils

VTAL-VER500A

Sensor Head containing 2 1/2" shaped coils and rail web sensor

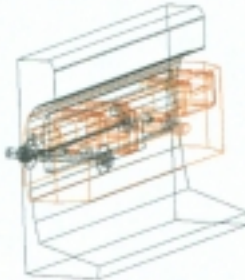

Mechanical Drawing of SH-0000

The **Sensor Assembly** head contain specially designed coils and high-quality capacitors potted in rugged, high-density polyethylene cases that bolt directly to the rail. The low weight of the sensors helps prevent loose mounting caused by shock and vibration. Their narrow profile also prevents much of the damage by dragging equipment encountered by other sensors. Depending on the application, sensor heads could contain one to three coils. The sensor cable is enclosed in a grounded and strengthened hydraulic hose to minimize damage from equipment.

| Overall Dimensions | | |
|-------------------------------------|------------|-----------|
| Length | 26.9mm | 10.6" |
| Width | 57.37mm | 2.258" |
| Height | 71.37mm | 2.8" |
| Distance from top of rail to top of | 6mm - 51mm | 1/4" - 2" |
| Weight | 1.5 kg | 3 lb |

Sensor Cable 2m 24-1/P twisted pair cable in 1/2" hydraulic hose
 Cable Fitting 1/2" male NPT

Assemblies:

DRVR-DC5200A

Driver Assembly to run HEAD SH-0000

DRVR-DC5200B

Driver Assembly to run HEAD TU-000A



Drawing of DRVR-DC5200 case

The **Driver Assembly** contain sophisticated circuitry to detect the change in coil impedance caused by the flange of a passing wheel. It also includes an open collector output that may be used to provide either an analog or digital signal as wheels are detected. The active components for a wheel sensor are mounted separately in a buntable waterproof housing or rugged junction box. This helps protect the components from lightning and power surges through the rail and also avoids problems caused by the severe shock and vibration of the rail. It also reduces replacement costs for damaged units since only the rail detector head or the driver board needs to be replaced if either is damaged. In addition, if the driver board fails, it may be replaced without having to work near the rail or unbolt the sensor head. The wiring between the Sensor Assembly and the wheel sensor head is contained in a waterproof, stainless-steel mesh reinforced hydraulic hose.

| Overall Dimensions | | |
|--------------------|------------------------|-------------------|
| Weight | 121.3 x 66.44 x 39.8mm | 4.8 x 2.6 x 1.57" |

Assemblies:

WCU - PKG

The housing for the DRVR-DC5200A comes in 3 different packages to suit the users requirement

The packaging requirements can be altered to suit the individual's needs, this ensures that existing wayside housings and cable can be used to reduce cost if need be. The codes that are illustrated here are those that are entered by the user on the system sheet tabs to enable FT to accurately calculate price and lead times

B

Bootleg

| Overall Dimensions | | |
|--------------------|---------|--------|
| Length | 27.03mm | 10.75" |
| Width | 27.03mm | 10.75" |
| Height | 60.96mm | 24" |
| Weight | | |

The Bootleg is a main line solution and can contain up to two driver boards, generally using AAR terminals.

JB

Junction Box

| Overall Dimensions | | |
|--------------------|---------|-------|
| Length | 27.94mm | 11" |
| Width | 16.51mm | 6.5" |
| Height | 8.26mm | 3.25" |
| Weight | | |

The Junction Box is an alternative to the above (designed primarily for yards) and is mounted on the tie by the sensor. WAGO connectors only

S

Special

Overall Dimensions To be supplied by customer
 In some locations, the above two options are not practicable; FT can offer a custom design solution or supply the system without the required housing.

Assemblies:

WCU - PKG

D

Drill Template

Each system is supplied with a drill template to ensure that the sensor bolts are mounted within 12.5 mm (1/2") of the rail's neutral axis for 60lb to 136lb rail.

AAR

Cables supplied with AAR Terminals

WAGO

WAGO connector type

Cable

FT uses a colour coded direct burial and shielded stranded 18 gauge wire for the ISO-LAN.

PREPARING DU4000A CONNECTIONS

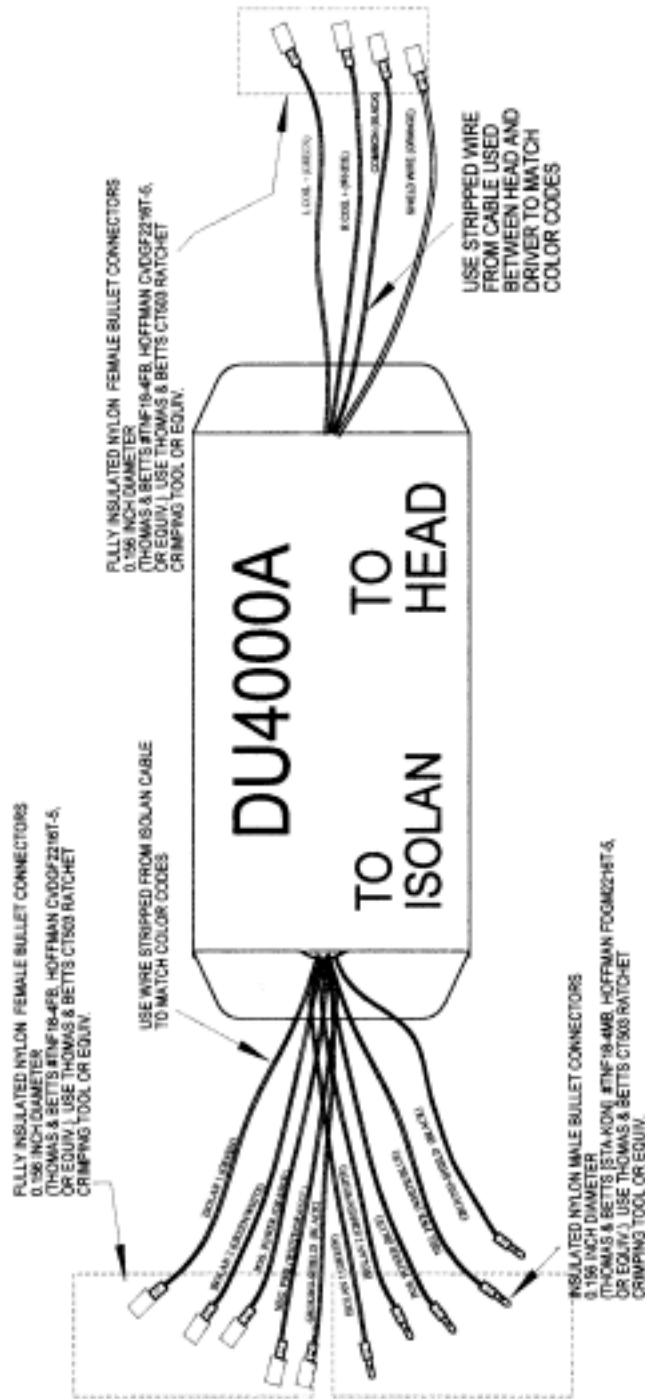

| CATALOG PRICING (USD) | | | | | |
|--------------------------------------|--------|-----------------|---------|--------|------|
| Wheel Counter Unit (WCU) | | ZPU** | \$1,150 | CMU*** | tbd‡ |
| Wheel Counter Sensor Head DU4000A | \$300 | NEMA enclosure† | \$150 | | |
| Driver Assembly (DRVR DC5200A) | \$400 | | \$150 | | |
| Bootlegs | \$300 | | | | |
| Special | tbd* | | | | |
| Junction Box | \$175 | | | | |
| Buried Cable | \$1.25 | | | | |

* *To be determined*

** *Zone Protection Unit*

*** *Communication Unit with Spread Spectrum Radio*

† *Enclosure that can be fitted outside in all weather conditions, meeting certain environmental requirements*

‡ *In the range of \$2,000 - \$3,000 depending upon radio type*

Installations

Paducah - Kentucky



This is a view of the RTI switch machine with the ZPU mounted in a NEMA 4 enclosure on the Paducah and Louisville Railroad (P&LR). The two IOS-LAN cables are visible; in general locations the cable would be buried.

Both the switch machine and the SPPS are powered by the solar panel.



The above is the system diagram for the Paducah Installation. The WCUs on the left (A & B) are configured as Points, C as Normal, and D as Reverse. This automatically sets up the appropriate outputs for the autoline function.



**TECHNOLOGY: Directional Lights
(Model 209 & 509)**

SUPPLIER: Carmanah Railway Lights

COUNTRY: Canada

[Our Products](#) » Model 209

Model 209

The directional blue light solution

Designed to meet Federal Railway Administration blue light legislation ([Code of Federal Regulations](#), Sec. 218.25 to 218.29), the Model 209 Railway Light can be temporarily or permanently installed for all types of directional blue light warning applications.

Utilizing an innovative, patented combination of solar and LED technologies, the 209 is a revolution in railway hazard lighting. It is completely self-contained and requires no maintenance or servicing for its entire lifespan of up to 5 years.

As a solar light, the 209 can be mounted anywhere there is sunlight. It can literally be installed in minutes using two bolts. Once in place, the unit charges itself during the day, even under cloudy conditions, and turns on automatically to emit a steady or flashing blue light throughout the night.

The 209 is engineered to outlast traditional blue signal lights using the latest in technology and manufacturing processes. The light features a polycarbonate lens and is fully enclosed in a powder-coated steel housing. The 209's proprietary design and construction makes it extremely durable, even under the harshest environmental conditions.

Other Benefits

- Meets [FRA regulations](#) for blue light signaling
- Expected operating life of up to 5 years with no servicing or maintenance
- No replacement of batteries or bulbs for entire lifespan
- Extremely rugged, waterproof and vandal-resistant
- Will withstand shock, vibration, collisions, extreme swings in temperature and many years of intense sunlight
- Available in steady on or flashing modes
- Visibility of over one mile in flashing mode
- Excellent autonomy - 14 days of operation without any additional solar charging
- Also available in red, amber and white light output
- Manufactured to [ISO 9001](#) Quality Assurance Standards
- [Three year limited warranty](#) and 30 day money-back guarantee
- An optional universal swing arm mounting bracket is also available



[Specifications](#)

[Dimensions](#)

[How to Install](#)

[Storage Tips](#)



[Download a Specification](#)

Pricing (USD)

| Item | Order Size | | | | |
|-------------|-------------------|-------------|--------------|---------------|----------------|
| | 1-5 | 6-20 | 21-50 | 51-100 | >100 |
| Model 209 | \$199.00 | \$179.10 | \$169.15 | \$159.20 | \$149.25 |

Carmanah Lights

MODEL 209

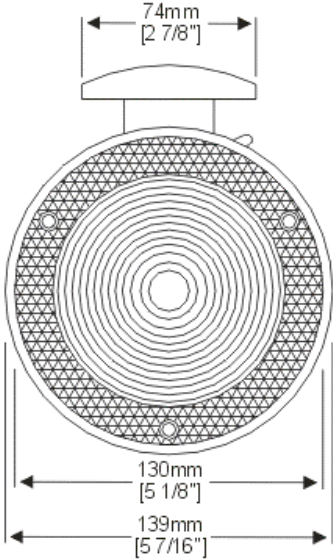

Front view

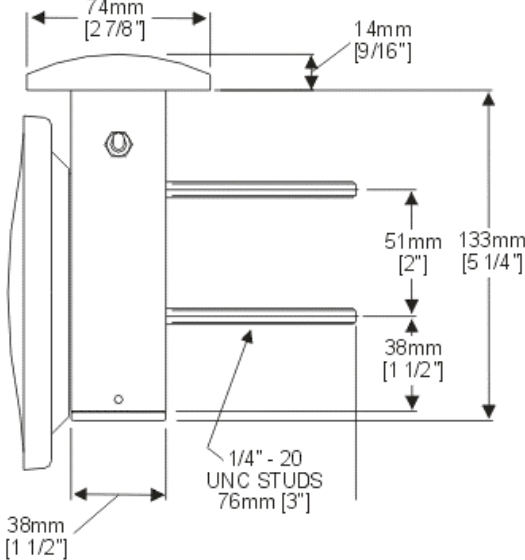

Side view

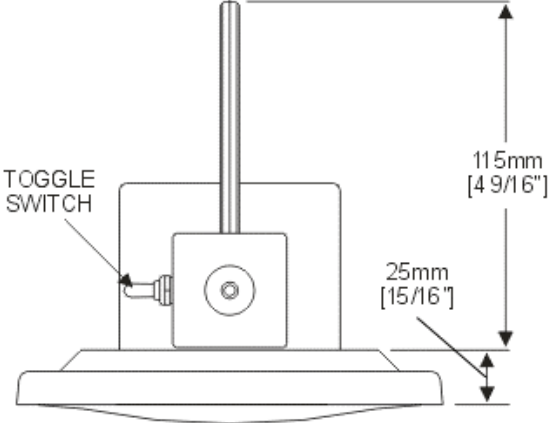

Bottom view

Our Products » Model 509

Model 509

The 360° blue light solution

Designed to meet Federal Railway Administration blue light legislation ([Code of Federal Regulations](#), Sec. 218.25 to 218.29), the Model 509 Railway Light can be temporarily or permanently installed for all types of blue light warning applications.

Utilizing an innovative, patented combination of solar and LED technologies, the 509 is a revolution in railway hazard lighting. It is completely self-contained and requires no maintenance or servicing for its entire lifespan of up to 5 years.

As a solar light, the 509 can be mounted anywhere there is sunlight. It can literally be installed in minutes using two bolts or screws. Once in place, the unit charges itself during the day, even under cloudy conditions, and turns on automatically to emit a steady or flashing blue light throughout the night.

The 509 is engineered to outlast traditional blue signal lights using the latest in technology and manufacturing processes. The light features a polycarbonate fresnel lens and is fully encapsulated in a shock and UV resistant polymer. The 509's proprietary design and construction makes it extremely durable, even under the harshest environmental conditions.

Other Benefits

- Meets **FRA regulations** for blue light signaling
- Expected operating life of up to 5 years with no servicing or maintenance
- No replacement of batteries or bulbs for entire lifespan
- Extremely rugged, waterproof and vandal-resistant
- Will withstand shock, vibration, collisions, extreme swings in temperature and many years of intense sunlight
- Available in steady on or flashing modes
- Visibility of over one mile in flashing mode
- Excellent autonomy - 14 days of operation without any additional solar charging
- Also available in red, amber and white light output
- Manufactured to **ISO 9001** Quality Assurance Standards
- **Three year limited warranty** and 30 day money-back guarantee
- An optional universal swing arm mounting bracket is also available



[Specifications](#)

[Dimensions](#)

[How to Install](#)

[Storage Tips](#)



[Download a Specification](#)

Pricing (USD)

| Item | Order Size | | | | |
|-------------|-------------------|-------------|--------------|---------------|----------------|
| | 1-5 | 6-20 | 21-50 | 51-100 | >100 |
| Model 509 | \$229.00 | \$206.10 | 194.65 | \$183.20 | \$171.75 |

Carmanah Lights

MODEL 509

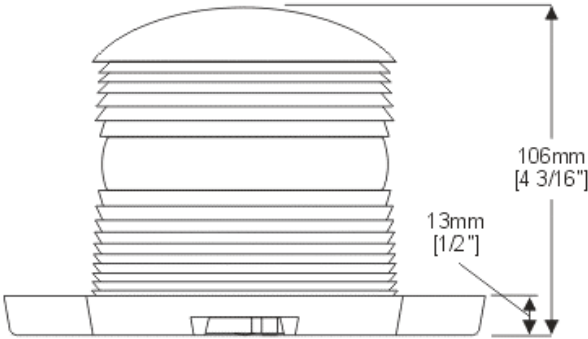

Side view

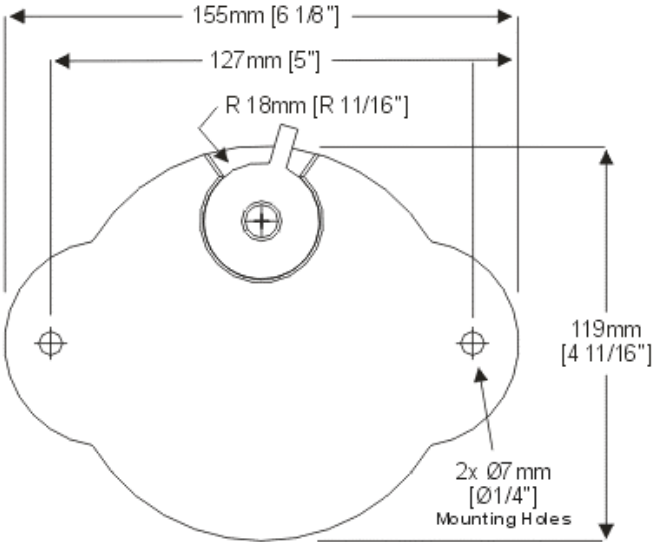

Bottom view

**TECHNOLOGY: Vital Harmon Logic Controller
(VHLC)**

SUPPLIER: GE Harris Harmon

COUNTRY: United States

VHLC

Vital Harmon Logic Controller

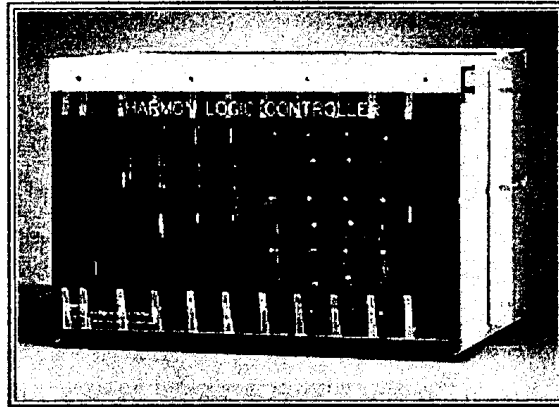

DESCRIPTION

The Vital Harmon Logic Controller (VHLC) is a multi-purpose solid state device for control of railroad interlocking plants. Its proven technology and reliability lead the North American rail industry in solid state interlocking control.

The VHLC provides control of power switch machines, DC lighting of signal lamps, interface to Electro Code track circuits and the DC track relays for the plant tracks.

Its software package, Applications Logic Compiler (ALC), allows signal design engineers to program vital signal logic for the VHLC using ladder logic diagrams. These diagrams closely resemble relay circuits.

FEATURES

- Provides direct vital switch machine control
- Direct control of signal lamps and mechanisms
- Provides code system emulation
- Controls Electro Code track circuits
- Provides code outputs to drive wayside cab energy converters

<http://216.247.86.33/Products/VitalIntSys/vhlc.html>

ADVANTAGES

- Flexibility in application
- Basic and advanced diagnostics with event history containing user mnemonics
- Interfaces directly to Electro Code track circuits
- Provides internal emulation of most code system protocols
- Replaces most vital and nonvital relays at an interlocking
- User-programmable application logic

COMPONENTS

BASIC VHLC SYSTEM

The basic VHLC system consists of the chassis, +5 volt power supply, VLP, ACP and SSM. Various configurations for different code system emulations are available.

VHLC CHASSIS

The VHLC chassis has positions for up to 12 modules. Of these 12 slots, 9 can be configured with various combinations of input/output modules as required for a specific application. Vital serial links allow up to 3 separate VHLC chassis to be connected together providing additional expansion. The following modules are available:

Vital Logic Processor (VLP)*

Auxiliary Communications Processor (ACP)*

Site Specific Module (SSM)*

+5 Volt Power Supply*

Coded Circuit Interface (CCI)

- Allows interface to one or two Electro Code track interface chassis (8 track circuits) and provides 16 code outputs to drive cab signal converters.

Vital Signal Driver (VSD)

- Provides 16 outputs for DC control of signal lamps. Hot and cold lamp filament tests allow detection of burned-out signal lamps.

Vital General Purpose Input/Output (VGPIO)

- Contains 8 vital inputs and 8 vital outputs.

16 Vital General Purpose Input (16VGPI)

- Contains 16 vital inputs.

8 Vital General Purpose Input (8VGPI)

- Contains 8 vital inputs.

Nonvital Input/Output (NVIO)

- Contains 16 nonvital inputs and 16 nonvital bipolar outputs.

32 Nonvital Input (32NVI)

- Contains 32 nonvital inputs.

SERIAL INTERFACE MODULES

Various serial interface modules provide communications capability with carrier, modems, data radio and wire line.

RS-232 Serial Interface

DC Code Line Interface Module

HLC Modem Module

Fiber Interface Module

RS-422/485 Module

Current Loop Adapter Module

ACCESSORIES

ELECTRO CODE TRACK INTERFACE

The Electro Code track interface chassis receives, monitors and transmits track signals. It can hold four Electro Code track interface circuits. Each VHLC chassis can interface with two of these chassis providing eight Electro Code track

<http://216.247.86.33/Products/VitalIntSys/vhlc.html>

circuits. The following circuit modules are available:

- Track Filter Module (9H)
- Regulated Track Converter Module (2R)
- Track Receiver Module (7K)
- Line Modules (2L, 7L, and 9L)
- Filter module (214)
- Cab Signal Filter Module (CSF-XX-TC)

LOCAL CONTROL PANEL

The local control panel accessory (LCP) is microprocessor based and communicates with the VHLC via the current loop adapter module. The LCP may be equipped with either a customized faceplate and corresponding track diagram; or one or more generic faceplates, consisting of a row of 16 toggle switches and 16 LEDs, without a track diagram.

SPECIFICATIONS

VHLC CHASSIS

ELECTRICAL

- Voltage: 10 to 16 VDC

OPERATING TEMPERATURE

- Minimum: -40°F / -40°C
- Maximum: +158°F / +70°C

RELATIVE HUMIDITY

- 95%, non-condensing

DIMENSIONS

- Width: 19"
- Height: 11.825"
- Depth: 12.75"

WEIGHT

- 33 lbs

TECHNOLOGY: Solid State Switch Monitor

SUPPLIER: GE Harris Harmon

COUNTRY: United States

SOLID STATE SWITCH MONITOR

This system has been designed to replace the entire point detector mechanism and point detector rods used with power-operated switch machines. This solid-state switch monitor improves the reliability of switch point detection systems.

The key components of this system are two PLC (Programmable Logic Controller) units with proximity sensors as required by commonly deployed switch machines.

The PLC units check and compare the inputs provided by the proximity sensors and switch request relays before energizing the NWC (Normal) or RWC (Reverse) switch correspondence relays.

FEATURES

- By eliminating the need for floating the lock rods, switch test and/or adjustments are simplified.
- Proximity sensors mounted on each switch point check the actual switch point to stock rail position.
- De-bounce time delay for the Normal (NWC) or Reverse (RWC) relay drivers prevents loss of switch correspondence resulting from momentary loss of input from one of the switch point sensors.
- Latch-out feature de-energizes the NWC or RWC correspondence relay drivers if switch point sensors switch off for more than two seconds.
- Latch-out can only be reset by positioning the switch with all inputs switching on or off in the proper sequence.
- Double break circuit protection provided through the use of two Programmable Logic Controller (PLC) units.
- Shunt protection on the PLC output relays is designed to de-energize the NWC or RWC output relays in the event that a failure of either of the PLC units occurs.

U.S Patent Number 5,806,809

TECHNOLOGY: DEMA – Monitor/Annunciator

SUPPLIER: GE Harris Harmon

COUNTRY: United States

DEMA - Monitor/Annunciator

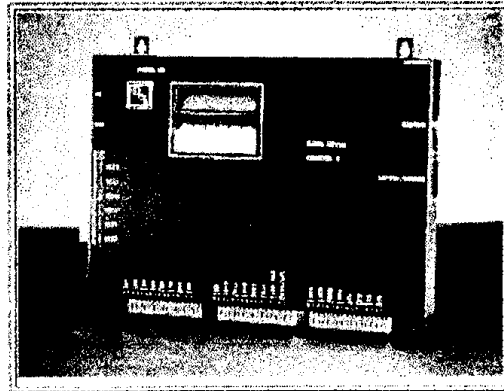

DESCRIPTION

The Monitor/Annunciator is used to monitor highway crossings and signal control points for proper operation and to report any alarm conditions to train crews via an onboard VHF radio. Analog channels permit battery bank monitoring and 'lamp out' detection. Extensive communication options are included, such as networking, central reporting, remote on-line crossing monitoring and ATCS support. Voice capabilities are customer programmable with an optional Speech Development Station.

User-defined tests may be programmed into the monitor to assist maintenance personnel with periodic inspections. The information can be retrieved on site via printer, laptop or handheld devices.

Programs can be added to the monitor to increase the testing and alarming capabilities. Unique setup menus can also be generated. Different menus can be displayed for single and double track installations.

FEATURES

- Hardened aluminum case
- Storage for 50,000 events
- 16 opto-isolated digital inputs

<http://216.247.86.33/Products/RcdrMonSys/DEMA.html>

- 40,000 bytes of user program availability
- 4 analog battery monitoring inputs
- 4 analog 'flashing light' inputs
- 6 relay outputs (front/back/heel)
- Built-in alarm reporting/networking
- Local data retrieval using the keypad and display
- Internal voice/data radio
- Laptop/printer serial port
- 2 opto-isolated DC/AC digital inputs
- 60 seconds of speech capability

ADVANTAGES

- Access to all I/O connections from front
- Shelf, wall or rack mounting
- Reports designed by railroad personnel for ease of use
- Can be programmed by user as a defect detection system
- Speech and data on same VHF radio

SPECIFICATIONS

DIGITAL INPUTS

- 16 powered opto-isolated inputs
- Range: 5-30 VDC @ 5 mA maximum load
- Inputs 15 and 16 usable for AC-powered inputs

BATTERY INPUTS

- 4 voltage channels range from 0-30 VDC @ 3 mA maximum load
- Inputs sampled every 10 ms, averaged over 100 ms time period
- User can define minimum change required to record event

COMMUNICATIONS

- Printer/laptop serial port
- Adjustable baud rates: 300 to 19,200
- Data bits: 7,8
- Stop bits: 1,2
- Parity: odd, even or none

POWER

<http://216.247.86.33/Products/RcrdrMonSys/DEMA.html>

- 8-36 VDC single supply @ 1.25 A max
- On-board battery backup for RAM and clock

OPERATING TEMPERATURE

- Minimum: -40° F
- Maximum: +165° F
- 0-90% non-condensing humidity

MEMORY

- 512 Bytes EEPROM
- 512 Kbytes Battery-Backed RAM
- 256 Kbytes EPROM

CLOCK

- Real-time clock with internal calendar
- Year Range: 1995-2094
- Recognizes leap years
- Can be programmed to enter and exit daylight saving time automatically

CURRENT INPUTS

- 4 current inputs rated @ 0-30 A RMS
- Optional Quad or Dual Current Sensing Module must be used to monitor warning lamps
- Channels may also be configured as 0-12 VDC analog inputs

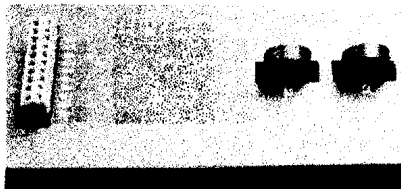

RELAY OUTPUTS

- 6 relay outputs available
- Provide front, back and heel contacts @ 4 amps maximum

RADIO/VOICE

- Internal Motorola RNET or RITRON two-channel voice/data radio with

<http://216.247.86.33/Products/RcrdrMonSys/DEMA.html>

- carrier detect
- 60 seconds of customer programmable speech using up to 6 messages or words
- Channels can be configured for normal and maintenance frequencies, allowing for alarm reporting or diagnostic testing

DIMENSIONS

- Height: 11"
- Width: 14"
- Length: 1.5"

WEIGHT

- 8 lbs

EVENT INTEGRITY

Multiple layers of data verification insure reliability of events, even through brownouts, power surges or outages. Events are not field-erasable. After reaching 50,000 events, the oldest event is automatically removed when a new event is recorded. The unit's internal battery retains the data in the absence of power. The Power Fail Circuit inhibits the processor from corrupting data when power is marginal. The Watchdog timer will restart the unit when errant software execution is detected. A unique event is recorded for Watchdog and normal restart operations.

Product information current as of September 2000

[Return to Products & Services](#)

[Return to Recorder and Monitor Systems](#)

[Home Disclaimer](#)

[Download Product Documentation](#)

**TECHNOLOGY: Wireless Remote Monitoring Device
(CellularRTU)**

SUPPLIER: LaBarge Inc.

COUNTRY: United States

THE CellularRTU ⁽¹⁾

The CellularRTU is the field component of the ScadaNET Network, a wireless communication system deployed throughout North America.. The CellularRTU is a family of multiple-channel, Internet accessible remote terminal units, engineered for monitoring and alarm reporting from remote locations. The system integrates proven communication technologies in everyday use. These technologies include the cellular telephone network, the Internet, e-mail, fax transmission, and pocket pagers, which can be used to create a powerful solution for alarm notification and periodic measurement applications.

The CellularRTU is available in a number of models and configurations. They all feature user-selectable digital and analog inputs. Some models meet the requirements for applications such as monitoring railroad crossing equipment.

All input and output circuitry is fully isolated, able to withstand extreme transient conditions. Optional battery backup systems ensure that critical functions will be continuously monitored in the event of power malfunctions.

Installation of a CellularRTU using the existing cellular telephone network wireless communications is simple and set-up is virtually automatic, using existing cellular telephone network wireless communications. No radio site surveys or special antennas are required and there is no need for frequency reallocation. All wireless communication is in digital form, which ensures that reliable communication is available even in areas where voice cellular coverage may be marginal.

The current status of each CellularRTU is available from its own secure Web page, visible only to authenticated users. This secure Internet access is also used to configure the operation of the entire system, including the definition of site names, locations and alarm. The recipients of alarm notifications can be established. Since a standard Web browser is the only host application required, no special software is necessary to access the ScadaNET Network.

The ScadaNET Network can provide notification of alarm conditions and events to multiple recipients, be it public or private. The network works 24 hours a day and triggers alert procedures if any operational or communication abnormalities are sensed. Data is secure and fully protected from unauthorized access.

End users can view many RTUs at once using Network Views. Through data entry screens available to system administrators, the channel names and other specific data are entered into the network. Alarms can cause automatic e-mail notifications to be triggered to any number of recipients. E-mail addressees may be ranked by priority and different timing criteria may be established, allowing secondary notification to alternative groups if any alarm condition persists beyond a desired limit (Hilleary, 2001). In addition, alarm notifications can be routed using fax transmission and/or alphanumeric pagers.

⁽¹⁾ All information has been taken as presented in material supplied by LaBarge Inc, ScadaNet Network™.

CellularRTU Configuration Application (Hilleary, 2001)

A configuration software allows each channel's behaviour to be established. Digital channels can be individually configured for different timing and linked to channel requirements. All channels can be configured to report both alarm and return-to-normal operation. This user-configured set-up capability allows the devices to monitor virtually any event at remote locations.

Service Availability and Coverage (Hilleary, 2001)

Some of the telecommunication organizations providing the cellular services throughout North America include US West, BellSouth, US Cellular, Bell Atlantic, CommNet, Airtouch and Cellular One.

CellularRTU Specifications⁽¹⁾

Model cRTU-2 Gemini[®]

Inputs

2 Channels, Digital or DC Analog, -2.5V to +2.5V, 0 to 5V, 0 to 50V
Analog Channel Resolution - 1mVolt
Input Impedance 20 Meg Ohms
All Input Channels Optically Isolated to 2500V

Internal Alarm and Diagnostics

Battery Status
Tamper Alarm
Radio Communication Metrics and Message Audit

Power Requirements

Lithium-Ion Battery, 6 Year Life, Nominal Operation
Optional 10 to 15VDC Power Supply
Optional 120VAC, 240VAC, and Solar Power Assist

Communications Specifications

Transport: Cellular Control Channel, Cellemetry and Microburst
RF Power Output: 3W Peak
FCC ID: APV0896

Physical and Environmental Specifications

Sealed Tamper-Proof Enclosure
Size: 3" L x 2" W x 6" H
Mounting: Flange Wall Mount or Pipe Mount, 3/4" to 2" Diameter
Weight: 4 lb
Operating Temperature: -40C to +70C
Storage Temperature: -40C to +85C

Regulatory Compliance

Class 1, Division 2, Factory Mutual 3611
ESD: EN 61000-4-2, 4kV Contact, 8kV Air Discharge
Radiated Immunity: EN 61000-4-3, 10V/m 80 MHz to 2GHz
Conducted Immunity: EN 61000-4-6, 10VRMS 150kHz to 2GHz
Radiated Emissions: FCC Part 15 Class B, EN55022 Class A
Conducted Emissions: EN55022 Class B
Voltage Deviation Immunity: EN 61000-4-11
Surge/Lightning Immunity: EN 61000-4-5, 2kV
Electrical Fast Transient: EN 61000-4-4, 2kV

Optional Equipment

120VAC Power Supply
240VAC Power Supply
Solar Power Assembly
Antenna, Exterior Surface Mount, Radome Style



The new Gemini[®] cRTU-2 is designed for one and two channel, battery-powered, monitoring and data acquisition applications.

* Users may experience reduced readability of the display outside of the specified operating temperature limits, and reduced capacity of the battery backup system below -20C.

Model cRTU-5, cRTU-6, cRTU-10

CRTU-5 Inputs & Outputs

4 Channels, Convertible Digital/Analog
1 Channel, Relay Output, SPST 6A@120VAC, 6A@24VDC

CRTU-6 Inputs & Outputs

5 Input Channels
Internal Power Input Monitor, 0-30VDC
3 Convertible Digital/Analog (Option 2ANA)
1 Fixed Analog 0-30VDC Input (Option 2ANA)
4 Convertible Digital/Analog (Option 1ANA)
1 Channel, Relay Output, SPST 6A@120VAC, 6A@24VDC

CRTU-10 Inputs & Outputs

8 Channels, Convertible Digital/Analog
2 Channel, Relay Output, SPST 6A@120VAC, 6A@24VDC

General Input Specifications

All Analog and Digital Input Channels Optically Isolated to 2500V

General Power Requirements

12 to 20VAC or VDC @ 40W (cRTU-5)
8 to 30VDC @ 40W (cRTU-6, cRTU-10)
Optional Standby Battery Capacity: 24 hours

General Communications Specifications

Transport: Cellular Control Channel, Cellemetry and Microburst
RF Power Output: 3W Peak
FCC ID: APV0896

General Physical and Environmental Specifications

CRTU-5 and cRTU-6 Size: 8" L x 5" W x 1.75" H Weight: 5 lb
CRTU-10 Size: 12" L x 5" W x 1.75" H Weight: 6 lb
Mounting: Flange Mount
Operating Temperature: -40C to +70C*

General Regulatory Compliance

ESD: EN 61000-4-2, 4kV Contact, 8kV Air Discharge
Radiated Immunity: EN 61000-4-3, 10V/m 80 MHz to 2GHz
Conducted Immunity: EN 61000-4-6, 10VRMS 150kHz to 2GHz
Radiated Emissions: FCC Part 15 Class B, EN55022 Class A
Conducted Emissions: EN55022 Class B
Voltage Deviation Immunity: EN 61000-4-11
Surge/Lightning Immunity: EN 61000-4-5, 2kV
Electrical Fast Transient: EN 61000-4-4, 2kV

Optional Equipment

Power Supplies
120VAC/240VAC Transformer
12V External Battery Backup System

Antennas

Exterior Surface Mount, Radome Style
External Yagi

Analog Input and Signal Conditioning Modules

0-5/30/300VDC, Single Channel, External
0-100mVDC, High Impedance, Single Channel, External
0-3VDC, High Impedance, Single Channel, External
AC Input Filter Module

⁽¹⁾ Taken from technical information supplied by LaBarge Inc.