

**SPECIFICATIONS: Current Status**

**Date: March 28, 2006**

<b>DIVISION/Section</b>	<b>Latest Revision Date</b>
<b>100 - General Provisions</b>	
101	2006.03.28
102	2006.03.28
103	2004.05.05
104	2003.03.27
105	1999.03.01
106	2006.03.28
107	2006.03.28
<b>200 - Earthwork</b>	
201	1994.03.28
202	1998.03.03
203	2005.04.15
204	1999.01.16
205	2003.03.27
206	2004.05.05
207	2004.05.05
208	2000.02.29
209	1999.01.16
210	2002.04.10
211	2003.03.27
212	2003.03.27
213	2006.03.28
214	2003.03.27
215	2003.03.27
216	2003.03.27
217	2006.03.28
218	2006.03.28
219	2002.04.10
220	2006.03.28

**GENERAL PROVISIONS AND CONTRACT SPECIFICATIONS FOR HIGHWAY CONSTRUCTION**  
Department of Transportation and Public Works  
Page 2

---

<b>300 - Drainage</b>	
301	2005.04.15
302	2004.05.05
303	2002.02.12
304	2006.03.28
305	2006.03.28
306	2001.03.10
307	2006.03.28
308	2000.02.29
309	2006.03.28
310	2006.03.28
311	2006.03.28
312	2003.03.27
Figures 312-01 & 312-02	Revised 2002
<b>400 - Granular Material</b>	
401	2006.03.28
402	1994.04.11
<b>500 - Bitumen</b>	
501	2004.06.22 (ERRTA)
502	1994.04.11
503	1994.03.28
<b>600 - Pavement</b>	
601	1994.04.11
602	2000.02.29
603	See Below
603.01/02	2004.05.05
603.03	2005.04.15
603.04	2000.02.29
603.05	2006.03.28
603.06	1997.05.16
603.07	1997.05.16

**GENERAL PROVISIONS AND CONTRACT SPECIFICATIONS FOR HIGHWAY CONSTRUCTION**  
Department of Transportation and Public Works  
Page 3

---

603.08/09	1997.05.16
603.10	2000.02.29
603.11	2000.02.29
603.12	2006.03.28
603.13	1997.05.16
603.14	2004.05.05
603.15	2006.03.28
603.16	2000.02.29
603.17/18	1997.05.16
604	1994.03.28
605	1994.03.28
606	1994.03.28
607	1994.04.11
608	1998.03.03
<b>700 - Rehabilitation</b>	
701	1999.01.13
702	2003.03.27
703	2000.02.29
704	2003.03.07
705	2003.03.27
706	2004.05.05
707	2005.04.15
708	1994.03.28
709	1996.04.15
710	1994.03.28
711	2004.05.05
712	2003.03.27
713	1999.01.13
714	2003.03.27
715	2002.02.9
<b>800- Environment</b>	
801	2000.04.19

# GENERAL PROVISIONS AND CONTRACT SPECIFICATIONS FOR HIGHWAY CONSTRUCTION

Department of Transportation and Public Works

Page 4

---

Figures 801-01, 801-02, 801-03, and 801-04	Revised 2002
802	1994.03.28
803	2000.02.29
804	2003.03.27
805	2003.03.27
806	2001.03.10
807	2001.03.10
808	2001.03.10
809	2005.04.15
810	2000.02.29
811	2004.05.05 (text did not change, put revision date 2001 on bottom of sketch Figure 811-02)
812	2004.05.05
813	2005.04.15 (New)
<b>900 - Safety</b>	
901	2005.04.15
902	2005.04.15
903	2005.04.15
Figure 903-01	Revised 2005
Figure 903-02	Revised 2006
Figures 903-03 and 903-04	2005 (New)
904	2003.03.27
Figure 904-01	Revised 2001
905	1994.03.28
906	2003.03.27
907	2002.04.10
Figures 907-01, 907-02 (1 of 2) and 907-2 (2 of 2)	Revised 2001
908	2004.05.05
909	2004.06.17
<b>1000 - Electrical</b>	

**GENERAL PROVISIONS AND CONTRACT SPECIFICATIONS FOR HIGHWAY CONSTRUCTION**  
Department of Transportation and Public Works  
Page 5

---

1001	1994.03.29
1002	1994.03.29
1003	1994.03.29
1004	2003.03.27
<b>1100 - Concrete</b>	
1101	2000.02.29
1102	2001.03.10
Figures 1102-01 and 1102-02	Revised 2002
1103	2005.04.15
Figure 1103-01 Figure 1103-02	Revised 2005 Revised 2001
1104	2000.02.29
<b>1200 - Miscellaneous</b>	
1201	1999.01.18
1202	1994.03.28
<b>1300 - Supplementals</b>	As required
Appendix 1	2006.03.28
Appendix 2	2006.03.28
Appendix 3	2005.04.15
Appendix 4	2003.03.27

**GENERAL PROVISIONS AND CONTRACT SPECIFICATIONS  
FOR HIGHWAY CONSTRUCTION**

DEPARTMENT OF TRANSPORTATION AND PUBLIC WORKS

---

**TABLE OF CONTENTS**

---

**DIVISION 100**

**GENERAL PROVISIONS**

- 101 Terminology and Definitions
- 102 Instructions to Bidders
- 103 Scope of Work
- 104 Control of Work
- 105 Legal Relations and Responsibilities
- 106 Prosecution and Progress
- 107 Payment

**DIVISION 200**

**EARTHWORK**

- 201 Clearing
- 202 Grubbing
- 203 Excavation
- 204 Topsoil Removal and Reinstatement
- 205 Borrow from Adjacent Land
- 206 Borrow From Pit
- 207 Granular Base
- 208 Fine Grading
- 209 Compaction
- 210 Preparing Shoulders
- 211 Shoulder Material
- 212 Topsoil for Landscaping
- 213 Random Rip Rap
- 214 Tap Drain Installation
- 215 Ditching
- 216 Culvert End Cleanout
- 217 Trench Excavation and Backfilling
- 218 Geotechnical Fabric
- 219 Geogrid Reinforcement
- 220 Bedding Material

**DIVISION 300**

**DRAINAGE**

- 301 Storm Sewer Pipe Installation
- 302 Catch Basin Installation
- 303 Catch Basin, Manhole and Valve Adjustment
- 304 Drain Tile Installation
- 305 Roadway Culvert Installation
- 306 Driveway Culvert Placement
- 307 Culvert Extension
- 308 Culvert Removal
- 309 Timber Box Culvert
- 310 Concrete Box Culvert
- 311 Multi-Plated Corrugated Steel Arch
- 312 Culvert End Treatment

**GENERAL PROVISIONS AND CONTRACT SPECIFICATIONS  
FOR HIGHWAY CONSTRUCTION**

DEPARTMENT OF TRANSPORTATION AND PUBLIC WORKS

---

**TABLE OF CONTENTS**

---

<b>DIVISION 400</b>	<b>GRANULAR MATERIAL</b>
	401 Aggregate
	402 Bedding Sand
<b>DIVISION 500</b>	<b>BITUMEN</b>
	501 Asphalt Cement
	502 Asphalt Prime
	503 Asphalt Emulsions
<b>DIVISION 600</b>	<b>PAVEMENT</b>
	601 Tack Coat Application
	602 Prime Coat Application
	603 Hot Mix Asphaltic Concrete - Compaction
	604 Chip Seal
	605 Double Emulsified Asphalt Slurry Seal
	606 Asphaltic Concrete Curb
	607 Asphalt Crack Filling
	608 Cold Mix Bituminous Patching Material
<b>DIVISION 700</b>	<b>REHABILITATION</b>
	701 Pulverize in Place
	702 Pulverize, Stockpile and Replace RAP
	703 Pulverize, and Stockpile RAP
	704 Cold Plane, Stockpile and Replace RAP
	705 Cold Plane Construction Joint
	706 Cold Plane and Patch
	707 Asphalt Reinforcement Mesh Placement
	708 Polystyrene Foam Board Placement
	709 Pavement Restoration
	710 Cutting Asphalt
	711 Excavate and Patch
<b>DIVISION 800</b>	<b>ENVIRONMENT</b>
	801 Check Dams
	802 Water for Dust Control
	803 Hydro Seeding
	804 Landscaping and Seeding
	805 Mulching
	806 Silt Fence
	807 Erosion Control Mats
	808 Sediment Trap
	809 Sodding
	810 Maintenance and Sediment Control
	811 Straw Bale Barrier
	812 Compost
	813 Gabions

**GENERAL PROVISIONS AND CONTRACT SPECIFICATIONS  
FOR HIGHWAY CONSTRUCTION**

DEPARTMENT OF TRANSPORTATION AND PUBLIC WORKS

---

**TABLE OF CONTENTS**

---

<b>DIVISION 900</b>	<b>SAFETY</b>
	901 Signallers
	902 Removal of Flex Beam Guiderail
	903 Erection of Flex Beam Guiderail
	904 Pavement Edge Delineation
	905 Temporary Marking
	906 Traffic Control Devices
	907 Vehicle Configurations and Restrictions
	908 Traffic Control Plan
	909 Installation of Guiderail End Treatment
<b>DIVISION 1000</b>	<b>ELECTRICAL</b>
	1001 Electrical General Provisions
	1002 Telephone Ductbank
	1003 Basic Materials
	1004 Traffic Signals
<b>DIVISION 1100</b>	<b>CONCRETE</b>
	1101 Cast-In-Place Concrete
	1102 Curb and Gutter
<b>DIVISION 1200</b>	<b>MISCELLANEOUS</b>
	1201 Chain Link Fence and Gates
	1202 Cash Allowance
<b>DIVISION 1300</b>	<b>SUPPLEMENTAL SPECIFICATIONS</b>
<b>APPENDIX 1</b>	<b>SAMPLE TENDER DOCUMENT</b>
<b>APPENDIX 2</b>	<b>ENVIRONMENTAL REQUIREMENTS</b>
<b>APPENDIX 3</b>	<b>TEMPORARY WORKPLACE TRAFFIC CONTROL MANUAL 2005</b>
<b>APPENDIX 4</b>	<b>WEIGH SCALE PROCEDURES</b>



**GENERAL PROVISIONS AND CONTRACT SPECIFICATIONS  
FOR HIGHWAY CONSTRUCTION**

DEPARTMENT OF TRANSPORTATION AND PUBLIC WORKS

---

**TERMINOLOGY AND DEFINITIONS**

**101**

---

101.01 Terminology

This document titled "General Provisions and Contract Specifications for Highway Construction", hereinafter referred to as 'this Document', contains information which is relevant to the administration of highway construction contracts.

This Document is divided into Divisions (i.e. 100), Sections (i.e. 101), Provisions (i.e. 101.01) and Sub-Provisions (i.e. 101.01.01). Unless otherwise specified in the text, all references to Specifications, Divisions, Sections, Provisions, Sub-Provisions, Tables or Figures shall refer to this Document.

Whenever in this Document it is provided that anything is, is to be or to be done, if, as, when or where "contemplated", "required", "directed", "deemed necessary", "permitted", "suspended", "approved", "directed", "unacceptable", "suitable", "satisfactory", "unsatisfactory", or "sufficient", such expressions shall have the same force as if followed by the words "by the Engineer" or "to the Engineer" as the case may be.

101.02 Definitions

Wherever, in any part of the Contract, the following words, expressions, pronouns or abbreviations are used, the intent and meaning shall be as follows:

**AASHTO:**

American Association of State Highway and Transportation Officials

**ASTM:**

American Society for Testing and Materials.

**Addendum:**

A change in a Tender issued prior to the time and date of Tender Closing, stated in the Advertisement, which has the effect of modifying the Tender. An addendum shall be considered as an integral component of the Tender and shall be deemed to take precedence over all other components of the Tender.

**Advertisement:**

A public or private announcement stating the name of the tender, a brief description of the tender, and the time, date, and location of the opening. The announcement shall either be published in the newspapers of P.E.I. or take the form of a letter of invitation.

**Bid Bond:**

A bond issued by a surety company on behalf of a Bidder to guarantee to the Department that the Bidder will procure a Performance Bond and will carry out the work if the agreement is executed by the Minister.

**Bidder:**

A person, partnership or corporation, acting directly or through a duly authorized representative, submitting a Tender for the work contemplated.

**Borrow:**

An excavated material used in the construction of a subgrade; the original source of which is located outside the right-of-way.

**GENERAL PROVISIONS AND CONTRACT SPECIFICATIONS  
FOR HIGHWAY CONSTRUCTION**

DEPARTMENT OF TRANSPORTATION AND PUBLIC WORKS

---

**TERMINOLOGY AND DEFINITIONS**

**101**

---

**Bridge:**

Any structure having a span of 3 meters or more which carries pedestrian or vehicular traffic.

**CGSB:**

Canadian General Standards Board

**CSA:**

Canadian Standards Association

**CSP:**

Corrugated Steel Pipe

**Certificate of Final Completion:**

A written statement prepared by the Engineer stating the date on which the work has been completed.

**Certificate of Final Quantities:**

A written statement of final quantities prepared by the Engineer and agreed to by the Contractor in writing.

**Certificate of Substantial Completion:**

A written statement prepared by the Engineer stating the date on which the work has been substantially completed.

**Construction Period:**

That time referred to in the contract during which the work can be carried out.

**Contract:**

The agreement between the Contractor and the Department covering the performance of the work and furnishing of construction materials. The Contract shall include the Advertisement, this Document, the Plans, the Agreement, Addenda, the Special Provisions, the Release from Liability and any Supplemental Agreements.

**Contract Limits:**

The geographic locations of the beginning and end of a project.

**Contract Time:**

The number of working days, as stipulated in the contract document, to complete the work.

**Contractor:**

The party of the first part to the Contract acting directly or indirectly through agents or employees, who is primarily liable for the acceptable performance of the Contract and also for the payment of all legal debts pertaining to the work.

**Culvert:**

Any structure not classified as a bridge which provides an opening under a roadway.

**Department:**

The Department of Transportation and Public Works of the Province of Prince Edward Island.

**GENERAL PROVISIONS AND CONTRACT SPECIFICATIONS  
FOR HIGHWAY CONSTRUCTION**

DEPARTMENT OF TRANSPORTATION AND PUBLIC WORKS

---

**TERMINOLOGY AND DEFINITIONS**

**101**

---

**Deputy Minister:**

The Deputy Minister of Transportation and Public Works of the Province of Prince Edward Island.

**Engineer:**

The person assigned by the Department to be in charge of the work, who is a Member of the Association of Professional Engineers of the Province of Prince Edward Island, acting directly or indirectly through a designated assistant or representative.

**Granular Base:**

A layer of granular material of specified type and thickness between the sub-base and the base of the pavement surface.

**Highway:**

The right-of-way which is reserved for use in construction of the roadway and its appertaining structures.

**Labour and Materials Bond:**

A bond issued by a surety company on behalf of the Contractor to guarantee to the Department that all claimants will be paid for labour and materials used on the work described in the terms of the Contract.

**Local Material:**

Material that has its source on Prince Edward Island.

**Minister:**

The Minister of Transportation and Public Works of the Province of Prince Edward Island.

**Overburden:**

A layer of partially organic material located immediately below topsoil which is unacceptable for use in construction and also unacceptable as topsoil.

**PCP:**

Pre-cast Concrete Pipe

**Pavement:**

A layer or layers of asphaltic or Portland cement concrete placed over an existing pavement, base, sub-base or subgrade.

**Performance Bond:**

A bond issued by a surety company on behalf of the Contractor to guarantee to the Department proper performance of the terms of the Contract.

**Plans/Drawings:**

Any plans, profiles, typical cross-sections, supplemental drawings or exact reproductions thereof, which are approved or stamped by the Engineer and show the location, character, dimensions and/or detail of the work to be done and which are to be considered part of the Contract.

**GENERAL PROVISIONS AND CONTRACT SPECIFICATIONS  
FOR HIGHWAY CONSTRUCTION**

DEPARTMENT OF TRANSPORTATION AND PUBLIC WORKS

---

**TERMINOLOGY AND DEFINITIONS**

**101**

---

**Principals:**

The officers and individuals holding more than a 10% interest in a corporation; the partners in a partnership or the owners of an unincorporated firm.

**Province:**

The Province of Prince Edward Island.

**RAP:**

Reclaimed Asphalt Pavement

**Roadbed:**

That portion of the roadway extending from shoulder line to shoulder line; in other words, the subgrade and shoulders taken as a unit.

**Roadway:**

That portion of the highway included between the outside lines of gutters or ditches including all appertaining structures and all slopes, ditches, channels, and waterways necessary for proper drainage and protection.

**SADT:**

Summer Average Daily Traffic

**Security Deposit:**

A deposit in the form of a certified cheque or bid bond as security as described in the Tender Form and Agreement for due fulfilment of the Contract.

**Schedule:**

A guideline whereby the contractor shows specific contract tasks being done on a time line.

**Slope:**

Rise to run expressed as a percent or run to rise expressed as a ratio.

**Snowtrap:**

A field adjacent to the right-of-way with a terrain that causes snow to gather upon the roadway.

**Specifications:**

All written or printed descriptions or instructions pertaining to the method and manner of performing the work or to the quantities and qualities of the materials to be furnished and work to be carried out under the Contract; this includes the Tender, this Document, Supplemental Specifications, Special Provisions and Addenda, together with all written agreements made or to be made pertaining to the method or manner of performing the work or to the quantities or qualities of materials to be furnished and works to be carried out under the Contract.

**Special Provisions:**

Special directions containing requirements peculiar to the work not adequately provided for by the Standard or Supplemental Specifications.

**GENERAL PROVISIONS AND CONTRACT SPECIFICATIONS  
FOR HIGHWAY CONSTRUCTION**

DEPARTMENT OF TRANSPORTATION AND PUBLIC WORKS

---

**TERMINOLOGY AND DEFINITIONS**

**101**

---

**Stop Work Order:**

An order given in writing by the Engineer which directs the Contractor to stop work. The order will state the reason, the conditions and the deadline for compliance with the order.

**Sub-base:**

A layer of material or specified type and thickness between the Subgrade and the Base.

**Subgrade:**

The earth or rock surface, whether in cut or in fill, that is prepared for the sub-base and base.

**Substantial Completion:**

The identity of a contract when the engineer has determined that all work associated with major items has been completed.

**Supplemental Specifications:**

Specifications which are supplemental to this Document.

**Surplus Material:**

Any and all unused material the Department has placed a value on and may be stockpiled for future use or transported to another site.

**Technician:**

An assistant to the Engineer who is assigned to make inspection of work performed or being performed or of materials furnished or being furnished or to do such other work as assigned by the Engineer.

**Tender:**

An offer by the Bidder for work on which the Department requires formal bids to be prepared and submitted.

**Tender Form:**

The approval form for work on which the Department requires formal bids to be prepared and submitted.

**Thickness:**

The compacted depth of a lift or layer of material after placement within the roadbed.

**Ticket:**

A voucher, issued by a designated employee of the Department at the point of origin of a load to a truck driver and delivered to a designated employee of the Department at the work site, describing the quantity of material upon which payment of the load is to be based, showing the project number; road name; contractor; source number; scale number; truck owner/ truck driver; truck and trailer plate numbers with number of axles on each; open or closed haul; haul length; date; time loaded and unloaded; signatures of Department weigher and checker (who cannot be the same person;) and volume in cubic metres if measured by volume, or gross weight, tare weight, and net weight of material in kilograms or pounds if measured by weight. The ticket shall indicate that it is for either Pit to Stockpile, Stockpile to Road, Void, or, Non-pay Item.

**GENERAL PROVISIONS AND CONTRACT SPECIFICATIONS  
FOR HIGHWAY CONSTRUCTION**

DEPARTMENT OF TRANSPORTATION AND PUBLIC WORKS

---

**TERMINOLOGY AND DEFINITIONS**

**101**

---

**Topsoil:**

A fertile, friable soil of loamy character that contains a normal amount of organic matter.

**Total Completion:**

The identity of a contract when all work which was described in the contract has been completed.

**Waste Material:**

A material of any form which is deemed of no use to the Department and is to be disposed of by the Contractor.

**Weigh Scale:**

A device used for the measurement of weight.

**Work:**

All of the work specified in the contract as contemplated.

**Work Day:**

Any calendar day from the time of commencement of the work until the completion of the work, other than Saturday, Sunday or Statutory holidays.

**GENERAL PROVISIONS AND CONTRACT SPECIFICATIONS  
FOR HIGHWAY CONSTRUCTION**

DEPARTMENT OF TRANSPORTATION AND PUBLIC WORKS

---

**INSTRUCTIONS TO BIDDERS**

**102**

---

102.01 Conformity of Work with Plans and Specifications

The Contractor shall perform all work and shall furnish all materials, unless specified elsewhere in the Contract, and complete the whole of the work in strict conformance with the plans and specifications.

102.02 Contents of Tender

The Department shall furnish the Bidder with a Tender Form and Agreement which will show an estimate of the various quantities of work to be performed, materials to be furnished and the time before which the work must be completed.

All papers bound, attached or supplied with the Tender Form and Agreement are a necessary part thereof and must not be removed from the Tender Package.

Special Provisions which are issued with the Tender Form and Agreement shall supersede all other components of the Tender but Addenda may be issued at any time prior to the time and date specified in the Advertisement for Tender Closing which may have the effect of modifying a Special Provision or any other Tender component.

Addenda issued within 24 hours of the closing date, which affect a change in scope to the contract, shall require an extension to the closing date of the tender. The Engineer shall determine the effect of a change in scope and the appropriate extension to the closing date required due to the effect.

102.03 Bidder Investigations

The Bidder shall fully investigate the site and become acquainted with the location and character of the terrain upon which the work is being undertaken. The Bidder shall also become familiar with the plans, profiles, specifications, both general and special provisions, soil borings and reports, and all other information concerning the work which may be supplied by the Department to those bidding the Contract.

No claims for extras will be entertained by the Engineer, unless the Bidder can show that the extra cost arose from unforeseen circumstances not covered by the information provided to Bidders by the Department, or not obvious to a prudent Bidder before entering into the Contract.

102.04 Preparation of Tender

The Bidder must submit the Tender on the forms furnished by the Department. The blank spaces in the Tender Form and Agreement must be filled in correctly for each and every item for which a quantity is given. The Bidder must write in ink the prices, both in words and numerals, for which the Bidder proposes to do each item of the work contemplated. The Bidder must extend the total for each item of the work and carry out a summation to the total value of the work to be done under the Tender. If the Tender Form and Agreement is made out by an individual, the individual's name and Post Office address must be shown; if it is made out by a firm or partnership, the name and Post Office address of each member of the firm or partnership must be shown; and if it is made out by a corporation, the person signing the Tender must show the name of the Province under the laws of which the corporation was incorporated and the names, titles, and business addresses of the President, Secretary and Treasurer.

**GENERAL PROVISIONS AND CONTRACT SPECIFICATIONS  
FOR HIGHWAY CONSTRUCTION**

DEPARTMENT OF TRANSPORTATION AND PUBLIC WORKS

---

**INSTRUCTIONS TO BIDDERS**

**102**

---

102.05 Delivery of Tender

Each Tender Form and Agreement must be submitted in a sealed envelope and marked:

"Tender for . . . . ."

The Tender must be received on or before the time and date of the Tender Closing specified in the advertisement.

If forwarded by registered mail, the sealed and marked envelope should be enclosed in another and sent to the Minister, Department of Transportation and Public Works, PO Box 2000, Charlottetown, Prince Edward Island, C1A 7N8; if forwarded other than by registered mail, it should be delivered to the Minister of the Prince Edward Island Transportation and Public Works, 11 Kent Street, Charlottetown, and a receipt should be obtained from the receiving person.

102.06 Rejection of Tender

Tenders will be rejected if they show any omissions, form alterations, additions not called for, conditional or alternate bids, or irregularities of any kind, or if they contain a clause in which the Bidder reserves the right to accept or reject a Contract awarded. The right to reject any or all Tenders is reserved by the Minister; and lowest or any Tender will not necessarily be accepted.

102.07 Bid and Performance Security

**Bid Security:**

The Tender shall be accompanied by either a certified cheque, a bid format irrevocable standby letter of credit on a Government approved form, or a bid bond equal to the amount specified in the Tender Form and Agreement. The bid bond shall be from a surety company authorized to do business in Canada guaranteeing to supply a performance bond and a labour and materials bond equal to the amount specified in the Tender Form and Agreement. The Bidder will forfeit the bid security to the Minister if the Bidder fails to enter into a Contract when called upon to do so.

**Performance Security:**

Performance Security shall be in the form of either a certified cheque, a performance format irrevocable standby letter of credit on a Government approved form, or a performance bond and a labour and materials payment bond equal the amount specified in the Tender Form and Agreement. The security in the form of a certified cheque shall be retained by the Department until a certificate of substantial completion is issued by the Engineer. The security in the form of an irrevocable standby letter of credit shall be retained by the Department until November 30<sup>th</sup> in the year of the Contract or until a certificate of substantial completion is issued by the Engineer. The security in the form of a bond shall be retained until the warranty period of one (1) year has elapsed. For any multi-year contract, a performance format irrevocable standby letter of credit must include an automatic renewal clause ensuring extension to the completion of the work. The Minister may limit the performance security to bonds to assure the completion of the work.



**GENERAL PROVISIONS AND CONTRACT SPECIFICATIONS  
FOR HIGHWAY CONSTRUCTION**

DEPARTMENT OF TRANSPORTATION AND PUBLIC WORKS

---

**INSTRUCTIONS TO BIDDERS**

**102**

---

When a Contract is to be completed over several construction seasons, the security in the form of a certified cheque or an irrevocable standby letter of credit shall be released in proportion to the amount of work completed in any one (1) year of the Contract. Bonds shall be retained until the warranty period has elapsed for the entire Contract.

All certified cheques, irrevocable standby letters of credit, and bonds are to be made payable to the Provincial Treasurer, Province of Prince Edward Island.

The Contractor will forfeit the performance security to the Minister if the Contractor fails to carry out the Contract when called upon to do so.

The Government approved templates for the Bid Format and Performance Format irrevocable standby letters of credit can be found in Appendix 1. Bidders who choose to use the letter of credit as security must provide them as shown on these approved templates. Any deviation from this standard template may be cause for rejection of the Tender. The letters shall be on the Bidder's preferred Financial Institutions letter head and shall be signed and sealed by personnel having proper authority.

102.08 Withdrawal of Tender

A bidder will be permitted to withdraw the Tender, unopened after it has been deposited, if a request is received by the Minister in writing prior to the latest time for receiving tenders.

102.09 Disqualification of Tender

Each Bidder shall submit only one (1) Tender.

102.10 Competency of Bidder

Bidders must be capable of performing the various items of work bid upon. Bidders shall, upon the request of the Department, provide a statement covering experience on similar work and a statement of their financial resources.

102.11 Material Guaranty

Upon the request of the Department, Bidders shall furnish a complete statement of the origin, composition and manufacture of all materials to be used in the construction of the work together with any manufacturers' instructions. Upon the request of the Department, Bidders shall furnish samples of any or all materials to be used in the work; these samples may be subject to testing as required by the Department to determine their quality and fitness for the work.

102.12 Open Truck Haul

For all truck haul for which Department tickets are issued, the Contractor shall permit any person, partnership or corporation to supply trucks for haulage of material to be used in the Contract, without giving preference to the Contractor's own trucks. The Contractor shall pay for trucks employed to haul materials to a work site at rates not less than the current government rates which may be re-established from time to time by the Department.

For those materials which are weighed for payment, only those trucks which can be fully supported by the scales as required by Measurements Canada, shall be permitted to haul.

**GENERAL PROVISIONS AND CONTRACT SPECIFICATIONS  
FOR HIGHWAY CONSTRUCTION**

DEPARTMENT OF TRANSPORTATION AND PUBLIC WORKS

---

**INSTRUCTIONS TO BIDDERS**

**102**

---

These trucks must also conform to the Vehicle Configurations and Restrictions as provided in Section 907 of these specifications.

For those materials which are paid by volume, the trucks must conform to the Vehicle Configurations and Restrictions as provided in Section 907 of these specifications.

The truck haul shall be considered to be that distance from the point of loading to the centre of the work being carried out in the Contract Agreement.

Truck haul shall be determined in advance of any material being delivered to the work site. The Department representative and the Contractor shall be in agreement with truck haul measurement, prior to commencing the work.

The Contractor shall limit the truck haul to those roads that can accommodate two-way traffic flow. In the case of the material source being located on a road that can not meet this requirement, the Contractor may be required to provide pull-off areas as directed by the Engineer.

The Contractor may stockpile materials one time only prior to their incorporation into the work. Stockpile sites shall be determined and approved in advance of the stockpiling of the materials. If the Contractor chooses to stockpile materials, then the longest haul shall be the open haul whether it is from the production site to the stockpile or from the stockpile to the work site. The Contractor shall install weigh scales in accordance with Section 107.03 at both the production site and the stockpile site. In the case of materials imported by barge, the barge unloading site shall be considered as the production site.

In the case of materials imported by truck, the Contractor must stockpile materials one time only prior to their incorporation into the work. The haul from the stockpile to the work site shall be the open haul and no scales shall be required at the production site.

102.13 Scheduling of the Work

The Contractor shall submit a schedule prior to being awarded the Contract. The Department shall notify the successful bidder. After receiving the notification, the Contractor shall have seven (7) working days to deliver an acceptable schedule. The schedule shall be limited to the number of working days as stipulated in the Tender Form and Agreement and shall be within the construction period as defined in Section 101.02 Definitions. The Department reserves the right to ask the Contractor to revise the schedule prior to the time of commencement of the work. In no case, shall the scheduled completion date surpass the time of completion as stated in the Tender Form and Agreement.

102.14 Errors or Omissions

The bidder shall notify the Department of any errors or omissions found in the Tender document prior to the opening date of the Tender.

102.15 References

All reference to acts, regulations, testing procedures, and methods shall be understood to be the latest update to such acts, regulations, testing procedures, and methods, unless stated differently in the Tender Form and Agreement.

**GENERAL PROVISIONS AND CONTRACT SPECIFICATIONS  
FOR HIGHWAY CONSTRUCTION**

DEPARTMENT OF TRANSPORTATION AND PUBLIC WORKS

---

**SCOPE OF WORK**

**103**

103.01 Quantities

The quantities set forth in Schedule C of the Tender Form and Agreement are based on estimated quantities. If when carrying out the work and/or supplying materials under the Contract, the quantities are foreseen to exceed the Contract amount, then the Contractor shall notify the Engineer. Contract quantity over-runs must be authorized in writing prior to the work being performed.

Either party may request a price adjustment when quantities on major items, as stated within the Tender Form and Agreement, vary by more than 25% from the contract quantity. Adjustments to unit prices, in the case of an over-run, shall be applied only to that quantity that is over and above 125% of the original quantity.

103.02 Changes and Alterations

The Engineer may, in writing, at any time, alter the quantity of work to be done or materials to be supplied. The Contractor shall continue with the work and either party may request unit price adjustments in accordance with Provision 103.01.

In the case where the changes and alterations within the Contract affect methods of construction and procedures, then either party may request in writing negotiations to take place to determine the price adjustments to the Contract. The work shall not continue until these negotiations are finalized; unless, in the Engineer's opinion, a stop work order would affect the safety of the travelling public or the completion of the Contract.

103.03 Extra Work

Work which can not be covered by any of the various items for which there is a bid price in the Contract shall be deemed as extra work. No additional work outside that which is included in the Contract shall be done by the Contractor except upon the written order of the Engineer.

Work that is deemed to be extra shall be paid in the order outlined below:

Firstly, the extra work will be paid for at rates agreed to by the Engineer and the Contractor prior to the extra work actually beginning.

Secondly, if the Engineer directs the Contractor to begin the extra work prior to rates of pay being agreed to by the Engineer and the Contractor, and a rate of pay for the item is contained within the regularly published PEI DOT&PW Standard Prices - Unbid Jobs, then the rates published in the Standard Prices - Unbid Jobs shall be used as the basis for payment. Note, if the work is carried out by a Sub-Contractor then the Contractor may add 5% to these rates.

Finally, if the Engineer directs the Contractor to begin the extra work prior to rates of pay being agreed to by the Engineer and the Contractor, and a rate of pay for the item is not contained within the regularly published PEI DOT&PW Standard Prices - Unbid Jobs then the amount to be paid for the extra work shall be calculated as follows:

The Contractor shall keep accurate records, as agreed upon, of quantities or costs and present an account of the cost of the change in the work, together with vouchers where

**GENERAL PROVISIONS AND CONTRACT SPECIFICATIONS  
FOR HIGHWAY CONSTRUCTION**

DEPARTMENT OF TRANSPORTATION AND PUBLIC WORKS

---

**SCOPE OF WORK**

**103**

applicable. The Contractor shall present the valuation in detail giving actual material trade price (not list price) and actual labour costs (including unemployment insurance and workers compensation premiums, vacation pay, etc.) and the actual cost of equipment rental, if not covered in the Province of Prince Edward Island Machinery Rental Rates. To these prices the Contractor may add the following percentage amounts to determine the total cost to the Owner.

1. For work involving the General Contractor only, the General Contractor adds 10% to his costs.
2. For work involving a sub-contractor only, the sub-contractor adds 10% to his costs, submits this price to the General Contractor who adds 5%.
3. For work involving the General Contractor and a Sub-Contractor, the Sub-Contractor adds 10% to his costs, submits his price to the General Contractor who adds 5%; to this amount the General Contractor adds the cost of his own work plus 10% of the cost of his own work only. The General Contractor does not add a further 5% to the cost of his own work.

Note: If the extra work includes machinery rental costs which are covered within the above noted Machinery Rental Rates publication then these costs shall be added to the subtotal of all other costs (ie no markup will be allowed by the Contractor actually doing the work, however the General Contractor may add 5% to a sub-contractors machinery rental rates) as calculated in any of the above methods numbered 1 through 3. Machinery costs which are not covered in the Machinery Rental Rates Publication will then be included in the calculations of the above methods numbered 1 through 3.

The cost of any extra work shall not include the costs of service vehicles or the wages of supervisory personnel except under special circumstances authorized by the Engineer.

The Engineer may request the Contractor to provide vouchers for all labour and materials used for extra work. All provisions of the Contract shall apply to extra work and no extra work shall cancel or impair the Contract.

**103.04 Final Cleanup**

Before the work will be accepted in accordance with Provision 103.05, the Contractor shall assure that the area within the limits of the Contract are cleaned of all rubbish, excess material, equipment, and temporary structures except for long term environmental structures. In addition, all ground grades shall match the surrounding terrain. Final cleanup costs shall be considered incidental to the performance of the work.

**GENERAL PROVISIONS AND CONTRACT SPECIFICATIONS  
FOR HIGHWAY CONSTRUCTION**

DEPARTMENT OF TRANSPORTATION AND PUBLIC WORKS

---

**SCOPE OF WORK**

**103**

103.05 Acceptance of the Work

The Engineer shall issue a Certificate of Substantial Completion and shall list any deficiencies to the Contract that need to be corrected by the Contractor.

The Engineer may accept any portion of the work when it is distinct and separate from the whole of the work.

The acceptance of any work does not alleviate the Contractor's responsibility for the quality of the work and materials supplied.

The Engineer shall accept the work when all of the work has been completed and inspected and there are no deficiencies, and issue a Certificate of Final Completion.

103.06 Subletting or Assigning of Contract

The Contractor shall name any Sub-Contractors to the Contract under Schedule E of the Tender Form and Agreement.

This clause does not apply to the supply of materials but upon the award of Contract, the Contractor shall be required to name the suppliers in writing prior to commencing work.

The Department reserves the right to reject any Sub-Contractor due to non-performance or inability to do the work.

In no case, shall any assignment or subletting of the Contract relieve the Contractor from responsibility for due performance and completion of the work.

**GENERAL PROVISIONS AND CONTRACT SPECIFICATIONS  
FOR HIGHWAY CONSTRUCTION**

DEPARTMENT OF TRANSPORTATION AND PUBLIC WORKS

---

**CONTROL OF WORK**

**104**

104.01 Authority

The Engineer is the Department's representative and has authority to assure that the Contractor completes all work in accordance with the plans and specifications. The Engineer shall determine the quantities of the work that are to be paid for under the Contract, and shall respond to all questions relating to the Contract.

The Engineer shall render decisions on all claims by the Contractor. The Contractor shall, at the Contractor's own expense, furnish all reasonable aid and assistance to the Engineer to enable proper inspection of the work.

Notwithstanding any Departmental inspections, the failure of the Engineer to condemn defective work or material shall not constitute a waiver of a specification or the acceptance of the defective work or material. The Contractor shall remain liable for any defective work or material and shall be responsible to correct any deficiencies.

104.02 Claims

All claims shall be submitted in writing to the Engineer prior to the acceptance of the work by the Department. The Contractor shall be required to submit in writing any additional information that may be requested for the purpose of assessing the claims. Failure to submit the additional information requested, in writing, will be sufficient cause for not accepting the claim.

104.03 Modification of Methods and Procedures

If at any time, the Engineer finds that the Contractor's methods, equipment and procedures are found to be unsafe or non-productive to the progress and quality of the work, then the Engineer may request in writing that the Contractor modify methods, equipment and procedures so that the safety, progress and quality of the work are maintained. Failure of the Contractor to comply with the Engineer's request may result in a stop work order being issued.

104.04 Plans and Working Drawings

Detailed plans of the existing conditions with a comprehensive description of the construction contemplated shall be available from the Department.

Working drawings showing shop details, erection diagrams, falsework, formwork, and any other such details that may be required for the work shall be submitted by the Contractor for approval prior to work commencing.

The approval of any working drawings shall not alleviate the Contractor from the responsibility for the soundness of such working drawings or for the work they represent.

The Contractor shall not deviate from the Contract plans or approved working drawings without approval in writing from the Engineer.

**GENERAL PROVISIONS AND CONTRACT SPECIFICATIONS  
FOR HIGHWAY CONSTRUCTION**

DEPARTMENT OF TRANSPORTATION AND PUBLIC WORKS

---

**CONTROL OF WORK**

**104**

104.05 Conflicts and Omissions

The onus is on the Contractor to report any conflicts or omissions within the Contract plans and specifications as soon as they become apparent. The Engineer shall determine which is to be followed and how the work is to be carried out. The Contractor shall not be entitled to additional compensation for work not specifically mentioned in the plans and specifications which is obviously necessary to complete the contracted work.

104.06 Lines and Grades

The Engineer will only set such stakes that are necessary to properly define the location, alignment, elevation and grade of the work. The Contractor shall give a reasonable notice of the time and place where the lines and grades will be needed.

All stakes, marks and reference points shall be carefully preserved by the Contractor.

The Contractor may be held responsible for the cost of replacing stakes, marks or reference points that, in the opinion of the Engineer, were disturbed unnecessarily when carrying out the work.

Whenever necessary, work shall be suspended for such reasonable time as may be necessary for the layout and inspection of any portion of the work. The Contractor shall not be allowed any extra compensation for this necessary suspension of the work.

104.07 Right of Entry

At any time during the work, the Department, its servants or agents, may enter the Contract limits for the purpose of constructing or installing such collateral works that are necessary for the completion of the work. The Contractor shall accommodate any collateral work by scheduling their work so as not to interfere.

In the case, where the Contractor has knowledge of the collateral work at the time of bidding or when the collateral work does not affect the Contractor's methods and procedures, no claim shall be allowed by the Contractor.

104.08 Contractor's Responsibility

The Contractor shall continually give attention to the work while it is in progress. The Contractor shall identify and place a competent and reliable representative with authority to act for the Contractor in charge of the work.

The Contractor shall at all times supply a sufficient number of personnel and equipment to assure that the work is diligently completed in accordance with the specifications and the time specified.

**GENERAL PROVISIONS AND CONTRACT SPECIFICATIONS  
FOR HIGHWAY CONSTRUCTION**

DEPARTMENT OF TRANSPORTATION AND PUBLIC WORKS

---

**CONTROL OF WORK**

**104**

---

104.09 Notice to Contractor

Any notice, order or direction given in writing by the Engineer to the Contractor or representative, shall be deemed 'given' whether delivered by hand, mail or by facsimile. Failure of the Contractor to respond to such notice, order or direction may result in a stop work order.

104.10 Damage by Vehicles and Other Equipment

If at any time damage is being done or is likely to be done to areas outside the limits of the Contract or to work already completed within the Contract, the Contractor, at the Contractor's own expense, shall make changes in the type of equipment or its use and shall alter loadings so as to remove the cause of such damage.

The Engineer may restrict the use of some local roads as haul routes in order to prevent damage to the road structures.

Any damage caused by the Contractor's vehicles or equipment while carrying out the work shall be repaired at the Contractor's own expense, unless such damage, in the opinion of the Engineer was unavoidable. Nevertheless, the Contractor shall take every reasonable step to avoid such damage.

104.11 Excess Loading of Motor Vehicles

The Contractor shall not cause or permit vehicles to be loaded beyond the legal limits as specified in the Roads Act and Regulations whether such vehicle is owned by the Contractor or otherwise.

Vehicles hauling materials to the work site which are weighed by Department personnel will not be issued a ticket if such weight is in excess of the specified legal limits.

104.12 Defective Work and Materials

No material shall be used in the work until it has been approved by the Engineer. All rejected material shall be removed and replaced with approved material at the Contractor's own expense.

If the Contractor fails to remove the defective work or material within 24 hours, the Engineer may issue a stop work order. The failure of the Engineer to disapprove of any defective work or materials does not alleviate the Contractor from responsibility for the work.

The work performed by the Contractor shall have a warranty period of 1 year from the date of substantial completion. If any failure due to poor workmanship or defective material occurs within the warranty period, the Contractor, at the Contractor's own expense, shall repair the deficiency.



**GENERAL PROVISIONS AND CONTRACT SPECIFICATIONS  
FOR HIGHWAY CONSTRUCTION**

DEPARTMENT OF TRANSPORTATION AND PUBLIC WORKS

---

**CONTROL OF WORK**

**104**

104.13 Materials Supplied by the Department

When the Department is supplying material under the Contract, the Contractor shall give the Department sufficient notice for the delivery of the material. When the Department is supplying liquid asphalt cement, the Contractor shall pick up the asphalt cement from the source designated in the Contract. If any damage is done to material by the Contractor after delivery, it shall be repaired or replaced at the Contractor's own expense.

104.13.01 Materials Supplied by the Contractor

When the Contractor supplies the material under the contract, the material shall meet all specifications and manufacturing standards for the type of material supplied. The unit bid price for the supply of material shall include all manufacturing costs, freight charges, royalties, duties and applicable provincial taxes.

The Federal Goods and Services Tax shall be calculated for all goods and services to be supplied by the Contractor and entered on Schedule "C" of the Tender Form and Agreement.

104.14 Utilization of Surplus Material and Disposal of Waste Material

All material which is not re-used on a project will be considered surplus unless the Engineer deems it to be waste. The Department will retain ownership and responsibility of all surplus material even if it is to be used outside the contract limits. If the Contractor is requested by the Engineer to move material off site or to stockpile and reload the material, the Contractor shall be compensated for the haul off site and/or the additional work of reloading the material. Once waste material is removed from the project site by the Contractor, the Contractor retains ownership and responsibility of the materials including responsibility for proper disposal or reuse of the materials in compliance with the Environmental Protection Plan of Appendix A2, any applicable Conditions-of-Approval for the Work, and all associated environmental acts and regulations such as the provincial *Environmental Protection Act* and the federal *Fisheries Act*.

The unit bid price shall be full compensation for the proper disposal or reuse of the material.

104.15 Pit Requirements

Prior to hauling of any material from any pit, the Contractor will make sure that the pit has a valid permit. No material shall be hauled from any pit to the work site without this permit in place.

The contractor is also required to maintain the entrance to a pit to allow safe passage of Departmental staff vehicles and trucks hauling material. Any damage caused by the failure to do so will be repaired at the Contractor's expense.

**GENERAL PROVISIONS AND CONTRACT SPECIFICATIONS  
FOR HIGHWAY CONSTRUCTION**

DEPARTMENT OF TRANSPORTATION AND PUBLIC WORKS

---

**CONTROL OF WORK**

**104**

---

104.16 Use of Tarpaulins

The Contractor shall assure that all trucks hauling material to and from the work site are equipped with tarpaulins which fully cover the truck box. The Engineer may direct that any or all loads entering or leaving the work site shall be covered from the point of loading to the point of unloading. Failure of the trucker to carry out the direction of the Engineer may restrict the trucker from hauling to the work site.

104.17 Environmental Protection

The Contractor shall carry out the work on the contract according to the Plans and Specifications and in such a manner so as to be in compliance with various Acts and Regulations of the Province of Prince Edward Island and/or the Government of Canada which concern the protection of the environment, and any approvals or permits issued to the owner or Contractor in accordance therewith. The Contractor shall carry out any extra work, as directed by the Engineer, to protect the environment in accordance with provision 103.03.

All Work shall be carried out in accordance with the following documents:

1. Specifications Manual Division 800 - Environment
2. Environmental Requirements, Appendix A2.
3. PEI Transportation Public Works Environmental Protection Plan

If the Contractor fails to protect the environment in accordance with the above, then a suspension of the work may be ordered as per Section 3 of Appendix A2- Environmental Requirements.

The Engineer may employ others to do whatever work is necessary for the protection of the environment and shall deduct the cost from any monies owed to the Contractor. Failure of the Engineer to act shall not relieve the Contractor of any contractual responsibility.

All pits or plants from which material is taken or produced for use in the work shall comply with the regulations of the Environmental Protection Act and Regulations now in place.

**GENERAL PROVISIONS AND CONTRACT SPECIFICATIONS  
FOR HIGHWAY CONSTRUCTION**

DEPARTMENT OF TRANSPORTATION AND PUBLIC WORKS

---

**LEGAL RELATIONS AND RESPONSIBILITIES**

**105**

105.01 Contractor Liable for Risks

Contractor shall assume all risks and contingencies in connection with the work and shall bear all loss or damage. If any such loss or damage shall occur before final completion, delivery and acceptance of the work, the Contractor shall immediately, at the Contractor's own expense, repair, restore and re-execute the damaged work within the specified time for completion. The Contractor shall repair, at the Contractor's own expense, all deficits and failures from any causes whatsoever whether such deficits or failures are due to the negligence of the Contractor or due to bad workmanship; and the Contractor shall indemnify and save harmless the Minister from any and all claims, losses or damages in respect thereof.

105.02 Contractor Liable for Damages

The Contractor shall use due care that no person or property is injured and that no rights are infringed in the prosecution of the work. The Contractor shall be solely responsible for all claimable damages. The Contractor shall, at the Contractor's own expense, shall make such temporary provisions as may be necessary to ensure the avoidance of any such damage, injury or infringement; to prevent the interruption of, or damage or menace to, the traffic on any public or private road; and to secure to all persons and corporations the uninterrupted enjoyment of all their rights during the performance of the work. The Contractor shall indemnify and save harmless the Minister from and against all claims and demands, losses, costs, damages, actions, suits or other proceedings.

105.03 Mail Boxes

The Contractor, at the Contractor's own expense, shall carefully remove and satisfactorily replace any mail boxes in order to carry out the Contract.

Any mail boxes damaged by the Contractor shall be repaired or replaced at the Contractor's own expense.

105.04 Insurance Requirements

The Contractor shall, without limiting its obligations for liabilities herein and at the Contractor's own expense, provide and maintain the following insurances in forms and amounts acceptable to the Minister.

Comprehensive General Liability in an amount not less than \$3,000,000.00 inclusive per occurrence against bodily injury and property damage. The Government of Prince Edward Island is to be added as an insured under this policy. Such insurance shall include but is not to be limited to the following:

- Products and Completed Operations Liability
- Owner's and Contractor's Protective Liability
- Blanket Written Contractual Liability
- Contingent Employer's Liability
- Personal Injury Liability
- Non-owned Automobile Liability
- Cross Liability
- Employees as Additional Insured
- Broad Form Property Damage

**GENERAL PROVISIONS AND CONTRACT SPECIFICATIONS  
FOR HIGHWAY CONSTRUCTION**

DEPARTMENT OF TRANSPORTATION AND PUBLIC WORKS

---

**LEGAL RELATIONS AND RESPONSIBILITIES**

**105**

Operation of Attached Machinery

Shoring, blasting, excavating, under-pinning, demolition, removal, pile driving and caisson work, work below ground surface, tunnelling and grading as application.

Elevator and Hoist Liability.

Automobile Liability in an amount not less than \$1,000,000.00 on all vehicles owned, leased, operated or licensed in the name of the Contractor.

All the foregoing insurance shall be primary and shall not require the sharing of any loss by any insurer of the Province and shall preclude subrogation by the Insurer against the Government of Prince Edward Island.

105.04.01 Proof of Insurance

A certified copy of the required insurance shall be submitted prior to commencing work and shall be subject to the Engineer's approval for adequacy of protection. Approval by the Engineer of any policy filed by the Contractor shall in no way relieve the Contractor of its obligations to provide the insurance referred to in the Contract, nor shall it imply that the policies are in accord with the terms of the agreement.

All required insurance shall be endorsed to provide the Government with 60 days advance notice of cancellation or material change.

The Contractor shall ensure that the Products and Completed Operations coverage, as applicable, shall be in force for the duration of the warranty period.

The Contractor hereby waives all rights of recourse against the Province with regard to damage to the Contractor's property.

The Contractor shall require and ensure that each Sub-contractor submits a certified copy of the required insurance in accordance with provision 105.04 Insurance Requirements.

105.05 Detours

No detour shall be established without the authorization of the Engineer.

The Engineer may indicate as a Special Provision to the contract that a detour will be put in place to divert traffic around the work zone. When such a provision is included in the Contract, all required traffic control devices will be erected, maintained and removed by the Department at the Department's expense. Other work required for the construction of such a detour shall be included in the bid items of the Contract.

Notwithstanding the preceding paragraph, the Engineer may order that a detour be implemented to divert traffic around the work zone if, in the opinion of the Engineer, the work zone is unsafe for the travelling public. When such a detour is implemented, all required traffic control devices will be erected, maintained and removed by the Department. If the detour is due to the Contractor not carrying out the work in accordance with Provision 105.07 the costs will be billed to the Contractor.

The Engineer may direct that any detour be removed and subsequently re-established from time to time. The Contractor shall be responsible for removing barricades from the travelled portion of the roadway, removing from view all signs pertaining to the detour, replacing

**GENERAL PROVISIONS AND CONTRACT SPECIFICATIONS  
FOR HIGHWAY CONSTRUCTION**

DEPARTMENT OF TRANSPORTATION AND PUBLIC WORKS

---

**LEGAL RELATIONS AND RESPONSIBILITIES**

**105**

barricades and replacing the signs pertaining to the detour. Such temporary removal and replacement of any detour shall not be measured for payment but shall be considered as incidental to the work.

105.06 Provision of a Road Through the Work

Unless otherwise provided, the Contractor shall, at the Contractor's own expense, make suitable provisions to accommodate all traffic, pedestrian or vehicular over any part of the highway upon which work is being performed under the Contract. The Contractor shall, with the least amount of inconvenience, provide for the safety of the travelling public during non-working hours, weekends and statutory holidays.

The work shall be completed progressively in order to assure a minimum disruption to the travelling public. The grading operation shall not proceed more than 1.5 km ahead of the placing of materials and in no case, shall more than 3 km of roadway remain unpaved within the Contract. Any work not affecting the original travelled way may proceed as directed by the Engineer.

105.07 Accommodating Traffic

Where pursuant to Provision 105.05, a detour is to be implemented to divert traffic around the work site, the Contractor shall provide signallers to direct traffic through the detour as required to comply with the provisions of the Traffic Control Procedures for Road Work of Appendix 3.

Where pursuant to Provision 105.06, a road is to be maintained through the work site, the Contractor shall provide, install, maintain and remove all traffic control devices, at the Contractor's own expense, as specified in the Traffic Control Procedures for Road Work of Appendix 3. All traffic control devices used in conjunction with the work shall conform to the standards of the Department with respect to size, shape, colour, symbol, message and reflectivity. The Contractor shall also provide signallers to direct traffic through the work site in accordance with the Traffic Control Procedures for Road Work of Appendix 3.

Without limiting the responsibility of the Contractor to properly notify the public of and protect it from traffic hazards, the Engineer may require the Contractor to provide additional notification or protection for the public.

If at any time the Contractor fails to provide safe passage and control of traffic on any existing road or detour for which the Contractor is responsible, and if the Contractor fails to immediately correct an unsatisfactory condition upon being directed, the Engineer may issue a stop work order and may immediately correct the unsatisfactory condition and take such other action as is deemed necessary to provide for the safe passage and control of traffic. The Engineer may deduct from any monies due to the Contractor on account of any cost. Failure to act on the part of the Engineer under this paragraph shall not relieve the Contractor from any contractual responsibilities.

**GENERAL PROVISIONS AND CONTRACT SPECIFICATIONS  
FOR HIGHWAY CONSTRUCTION**

DEPARTMENT OF TRANSPORTATION AND PUBLIC WORKS

---

**LEGAL RELATIONS AND RESPONSIBILITIES**

**105**

105.08 Access to Adjoining Property

Adequate vehicular and pedestrian access to all properties adjacent to the work shall be provided at the Contractor's own expense.

When interruptions are necessary due to the nature of the work, the Contractor shall notify the landowners 24 hours in advance of the disruption. The Contractor shall schedule the work to minimize the effect of such disruptions.

105.09 Protection of Utilities

The Contractor shall be responsible for determining the location of all utilities located within the work area prior to commencing the work. During the course of the Contract, it is the Contractor's responsibility to consult with municipal authorities or utility companies for further information in regard to the exact location of these utilities; to exercise the necessary care in construction operations; and to take such precautions as are necessary to safeguard the utility from damage. The Contractor shall, at the Contractor's own expense, dig excavation pits for the location of any underground utility.

The preceding paragraph shall in no way relieve the Contractor of any obligations under various provisions of the Contract dealing with the Contractor's responsibilities for damage claims.

Damage to any utility, that the Engineer deems to be unavoidable due to the prosecution of work, shall be handled as Extra Work in accordance with Provision 103.03. No claims will be allowed for additional work required in locating any utility or for damage caused by the Contractor that, in the opinion of the Engineer, was avoidable.

105.10 Use of Explosives

The Contractor shall conform to all regulations of the Occupational Health and Safety Act pertaining to the use and handling of explosives. Blasting shall be controlled electrically and the total electrical requirements of the circuits shall be within the stated capacity of the electrical equipment. Charges are to be a size and number compatible with the requirements of the project. In addition to standard signals at the time of blasting, the Contractor shall warn all affected residents in advance that blasting will take place. Storage and transportation of explosives shall be in accordance with the provisions of the Explosives Act and any other requirements requested by the representative of the Explosive Division of the Federal Department of Energy, Mines and Resources.

**GENERAL PROVISIONS AND CONTRACT SPECIFICATIONS  
FOR HIGHWAY CONSTRUCTION**

DEPARTMENT OF TRANSPORTATION AND PUBLIC WORKS

---

**LEGAL RELATIONS AND RESPONSIBILITIES**

**105**

105.11 Protection Against Royalties and Patented Inventions

The Contractor shall indemnify and save harmless the Department from all and every claim for damages, royalties or fees for the infringement of any patented invention or copyright occasioned in connection with work done or material furnished under the Contract.

105.12 Protection of Survey Monuments

The Contractor shall be responsible for the cost of replacement of any geodetic bench mark, survey monument or property marker which is disturbed or destroyed in the course of the work unless such disturbance or destruction is previously authorized in writing by the Engineer.

**GENERAL PROVISIONS AND CONTRACT SPECIFICATIONS  
FOR HIGHWAY CONSTRUCTION**

DEPARTMENT OF TRANSPORTATION AND PUBLIC WORKS

---

**PROSECUTION AND PROGRESS**

**106**

---

106.01 Time and Order of Completion

The Engineer may direct the Contractor, in writing, as to the time, precedence or order in which any work is to be done under the Contract.

106.02 Time of Commencement

The Contractor shall commence work in accordance to the Schedule of Work submitted under Section 102.13, unless directed otherwise by the Engineer, and shall proceed continuously, diligently and with all reasonable dispatch consistent with the proper execution of the work until final completion. The rate of progress shall be such to ensure its final completion within the specified time.

After the schedule has been approved, any changes to the date of commencement will require a minimum of one week's notice to the Engineer and approval from the Engineer to allow for the proper utilization and scheduling of Department workers.

The Contractor must advise the Engineer 48 hours in advance of the need for required employees.

106.03 Time of Completion

The whole of the work to be done under the Contract shall be completed in accordance to the Schedule of Work submitted under Section 102.13. In no case shall the Time of Completion exceed the completion of work date as specified in the Tender Document.

106.04 Extension of Time

An extension of time may be granted in writing by the Engineer in the event of the work being delayed due to a change of scope in the work, a significant unit quantity increase, loss of production due to above average weather conditions, delays in material supplied by others and any other causes beyond the Contractor's control. Such extensions shall be for such time as the Engineer may prescribe, and the Engineer shall fix the terms on which the said extension may be granted. An application by the Contractor for an extension of time as herein provided shall be made to the Engineer, in writing, prior to the end of the specified contract time. Where applicable, all bonds or other surety furnished to the Department by the Contractor shall be amended where necessary at the expense of the Contractor to provide coverage beyond the date of any extension of time granted, and the Contractor shall furnish the Department with evidence of such amendment of the bonds or other surety.

Any extension of time that may be granted to the Contractor shall be so granted and accepted without prejudice to any rights of the Department whatsoever under the Contract. All such rights shall continue to be in full force and in effect after the specified construction period.



**GENERAL PROVISIONS AND CONTRACT SPECIFICATIONS  
FOR HIGHWAY CONSTRUCTION**

DEPARTMENT OF TRANSPORTATION AND PUBLIC WORKS

---

**PROSECUTION AND PROGRESS**

**106**

---

106.05 Liquidated Damages

The Contractor shall pay liquidated damages for each working day beyond the number of working days as specified in the Contract or beyond any extension of time that may be granted in accordance with Provision 106.04.

The liquidated damages for work being carried out on Routes 1, 1A and 2 shall be assessed at \$1,000.00 per day for each day beyond the time of completion. For work carried out on other highways or within any tendered project outside of highways limits, liquidated damages shall be assessed at \$700.00 a day for each day beyond the time of completion.

106.06 Non-Fulfilment of the Contract

If the Contractor fails to complete or carry out the work under the terms of the Contract, the Engineer may notify the Contractor in writing to discontinue all work. The Engineer may employ such other means that may be necessary to complete the work and, in such case, the Contractor shall have no claims for further payment for loss or damage against the Department. If the cost for completing the work exceeds the sum which would have been paid under the Contract, then the Department shall deduct the additional cost from any monies due or surety that the Contractor has in place.

106.07 Suspension of Work

The Contractor shall, upon written notice from the Engineer, discontinue or delay any or all work and the work shall not be resumed until the Engineer directs so in writing.

106.08 Termination of Contract

The Minister may at any time, by notice in writing to the Contractor, terminate the work or any portion thereof and the Contractor shall thereupon be entitled to payment for all work performed by the Contractor as of the date of termination.

106.09 Labour Disputes

Except to the extent that relief is granted under Provision 106.04, the Contractor shall bear the risk and responsibility of any loss, damage or expense to the work or to the Contractor arising from strikes or labour disputes other than such loss, damage or expense caused by the failure of the Department to meet its contractual obligations.

106.10 Character and Employment of Workers

Whenever the Engineer informs the Contractor, in writing, that any person or persons involved in the work are, in the opinion of the Engineer, incompetent, unfaithful or disorderly, such person or persons shall be discharged from the work and shall not again be employed on the work without the consent, in writing, of the Engineer.

**GENERAL PROVISIONS AND CONTRACT SPECIFICATIONS  
FOR HIGHWAY CONSTRUCTION**

DEPARTMENT OF TRANSPORTATION AND PUBLIC WORKS

---

**PROSECUTION AND PROGRESS**

**106**

---

106.11 Permits and Licenses

Permits and licenses of a temporary nature normally required for the prosecution of the work shall be secured and paid for by the Contractor.

No extension of time for completion of the work will be allowed due to a delay in the Contractor obtaining any licenses or permits.

106.12 Limitation of Operations

Except for such work as may be required to maintain the travelled roadway in a safe and satisfactory condition for traffic, the Contractor shall not carry out operations under the Contract between a half ( $\frac{1}{2}$ ) hour before sunset and a half ( $\frac{1}{2}$ ) hour after sunrise on any working day, or at any time on Saturday, Sunday or statutory holidays.

The Engineer may require the Contractor to work on Saturdays, Sundays or Statutory holidays to assure the safety of the travelling public. In addition, the Engineer may require the Contractor to work on Saturdays in order to complete the work.

The Engineer may in writing require the Contractor to cease or limit operations under the Contract, on any working day or days, if the operations are of such nature, or if the work is so located, or if the traffic is of such volume that the Engineer deems it necessary or expedient to do so.

106.13 Occupational Health and Safety Act

The Contractor is required to carry out the work in accordance to the Occupational Health and Safety Act of Prince Edward Island. The Contractor will not be entitled to any extension of time or additional monies due to delays arising from a stop work order issued under the Occupational Health and Safety Act.

106.14 Workers' Compensation Insurance

Prior to commencing the work and prior to receiving payment on the Certificate of Substantial Completion, the Contractor shall provide evidence of compliance with the requirements of the Province with respect to Workers Compensation Insurance including payment due thereunder.

At any time during the term of the Contract, when requested by the Engineer, the Contractor shall provide such evidence of compliance.

**GENERAL PROVISIONS AND CONTRACT SPECIFICATIONS  
FOR HIGHWAY CONSTRUCTION**

DEPARTMENT OF TRANSPORTATION AND PUBLIC WORKS

---

**PAYMENT**

**107**

---

107.01 Payments to the Contractor

Progress payments equal to 85% of the value of work completed, as determined by the Engineer, will be made monthly to the Contractor as the work progresses. Such progress payments shall be based on a written progress estimate prepared by the Engineer. The 15% holdback is to meet the requirements of the *Mechanics' Lien Act*. When requested by the Engineer, the Contractor shall supply a statutory declaration that 80% of the monies the Contractor owes in carrying out the work to date has been paid.

The Engineer shall deduct any liquidated damages from all payments made to the Contractor.

The Engineer shall make a deduction for any defective or deficient work from all payments made to the Contractor, except the final payment. The Engineer shall deduct either double the Engineer's estimated costing for the defective or deficient work or an amount set at the Engineers discretion for the repair of any defective or deficient work.

Notwithstanding the foregoing, no payment shall be construed to be an acceptance of any defective work or material.

The Engineer may release the holdback no less than 60 days after the date of substantial completion, provided that the Contractor has submitted a statutory declaration stating that all monies the Contractor owes in carrying out the work have been paid. The Contractor shall also provide evidence of compliance with the requirements of Workers' Compensation insurance.

After the Engineer is satisfied that all work associated with the contract has been completed, a Certificate of Final Completion will be issued and a Certificate of Final Quantities will be presented to the contractor. Final payment, ensuring that all quantities in the contract will be paid at 100% of their value will be made once the Contractor accepts the Certificate of Final Quantities.

107.02 Measurement of Excavated Materials by Volume

Whenever the Contract requires the payment for excavation at a price per cubic metre, the volumes shall be measured in their original position and computed in cubic metres by the method of average end areas unless otherwise specified.

107.03 Measurement of Weighed Materials

Where the Contract includes tender items that require measurement for payment by weighing, the Contractor, shall provide, install and maintain as necessary, weigh scales meeting the requirements of the Government of Canada Weights and Measures Act and Regulations, and in accordance with the Weigh Scale Procedures of Appendix 4.

Where an individual line item for granular material exceeds 3000t, the contractor shall ensure that scales of a minimum of 18.3m (60ft) are used to weigh the material.

If the contractor has more than one certified scale at the source, the longer scale shall be the scale of record. In the event the shorter scale is equal or greater than 18.3m (60ft) either scale can be considered the scale of record.

**GENERAL PROVISIONS AND CONTRACT SPECIFICATIONS  
FOR HIGHWAY CONSTRUCTION**

DEPARTMENT OF TRANSPORTATION AND PUBLIC WORKS

---

**PAYMENT**

**107**

---

Weight measurements shall be made by the weigher supplied by the Department.

When a platform scale is being used on the Contract, the tares of the hauling vehicles will be determined before work commences and as required by the Engineer. Vehicles which are being weighed for the tare, shall contain the normal hauling complement of a driver and accessories such as spare tires and tools. Each truck and each coupled vehicle combination shall have a distinguishing number prominently displayed where it will be readily visible to the weigher. The distinguishing number shall be a minimum of 125mm high and located at the top front corner on both sides of the trailer box of all pup trailers, semi-trailers, belly dump trailers and flow-boy trailers. The distinguishing number for a trailer must be the same as the number plate issued by Highway Safety Division for that trailer.

All costs of providing, installing, maintaining and testing weighing equipment in accordance with this specification and the cost of any delay and inconvenience which may result shall be borne by the Contractor as part of the work to be carried out at the Contract price for the items which are measured for payment by weighing; however, the Contractor will not be charged for labour and equipment supplied by the Department to carry out tests and checks.

107.04 Measurement of Quantities Delivered by Volume

When materials are being paid by volume delivered, payment will be based on truck measurement.

107.05 Payment of Workers

The Contractor shall, in addition to any fringe benefits, pay the workers employed by the Contract at wage rates, not less than those established by the Minimum Wage Order, issued under authority of the Labour Act. The Contractor shall pay workers employed on the work at intervals of not less than twice a month.

The Contractor shall require each Sub-Contractor, or other person doing any part of the work, to covenant with the Department that workers employed on the work by such Sub-Contractors, will be paid at the wage rates and intervals in accordance with this Provision.

Where any person employed by the Contractor or any Sub-Contractor, or other person on work contemplated by this Contract, is paid less than the amount required to be paid under this Contract, the Department may deduct from any monies payable to the Contractor under this or any other Contract, and pay to such person a sum sufficient to bring that person's wages up to the amount required.

No claim for extra payment from the Contractor will be considered by the Department concerning any change in the Minimum Wage Order which may occur during prosecution of the Contract.

107.06 Haulage

The cost of open truck haul, in accordance with Provision 102.12 shall be included in the unit bid price for all bid items measured in tonnes or cubic metres. If the truck haul rate should change after the tender call, then the unit bid prices shall be adjusted to accommodate the change.

**GENERAL PROVISIONS AND CONTRACT SPECIFICATIONS  
FOR HIGHWAY CONSTRUCTION**

DEPARTMENT OF TRANSPORTATION AND PUBLIC WORKS

---

**PAYMENT**

**107**

---

107.07 Records of Contractor Open for Inspection

The Contractor's payrolls, time books, account books, invoices and statements shall be, at all times, open for inspection and extraction by the Engineer or any authorized representative of the Minister. The Contractor shall assist enable the Engineer or representative to ascertain as far as possible, the exact payment, sums or claims so due and remaining unpaid by the Contractor.

**GENERAL PROVISIONS AND CONTRACT SPECIFICATIONS  
FOR HIGHWAY CONSTRUCTION**

DEPARTMENT OF TRANSPORTATION AND PUBLIC WORKS

---

**EARTHWORK**

**200**

- 201 Clearing
  - 202 Grubbing
  - 203 Excavation
  - 204 Topsoil Removal and Reinstatement
  - 205 Borrow from Adjacent Land
  - 206 Borrow From Pit
  - 207 Granular Base
  - 208 Fine Grading
  - 209 Compaction
  - 210 Preparing Shoulders
  - 211 Shoulder Material
  - 212 Topsoil for Landscaping
  - 213 Random Rip Rap
  - 214 Tap Drain Installation
  - 215 Ditching
  - 216 Culvert End Cleanout
  - 217 Trench Excavation and Backfilling
  - 218 Geotechnical Fabric
  - 219 Geogrid Reinforcement
  - 220 Bedding Material
-

**GENERAL PROVISIONS AND CONTRACT SPECIFICATIONS  
FOR HIGHWAY CONSTRUCTION**

DEPARTMENT OF TRANSPORTATION AND PUBLIC WORKS

---

**CLEARING**

**201**

---

201.01 Description

Clearing shall consist of the removal and disposal of all trees, shrubs, fallen timber, logs and other surface litter within the right-of-way and other areas as directed and designated by the Engineer.

201.02 Construction Method

Areas to be cleared shall be marked or staked by the Engineer prior to any clearing operation.

All brush and trees, shall be cut off at a height no greater than 300 mm above ground.

Timber of any value shall be cleared of limbs and piled neatly outside the right-of-way unless otherwise directed by the Engineer. All timber shall be the property of the Department.

All brush and other debris resulting from the clearing shall be burned without damage to adjacent property, or otherwise disposed of at the Contractor's own expense, as the Engineer may direct. Burning shall be in accordance with the Provisions of the Forest Act and Regulations. The Contractor shall take precautions to prevent the fires from spreading and shall be liable for any damages caused in the performance of this work.

201.03 Method of Measurement

The quantity to be measured under this Section shall be the number of hectares actually cleared derived from measurements made by the Engineer.

201.04 Basis of Payment

Clearing will be paid for at the unit bid price per hectare and this price shall be full compensation for tools, machines, labour and incidentals necessary to perform the work.

**GENERAL PROVISIONS AND CONTRACT SPECIFICATIONS  
FOR HIGHWAY CONSTRUCTION**

DEPARTMENT OF TRANSPORTATION AND PUBLIC WORKS

---

**GRUBBING**

**202**

202.01 Description

Grubbing shall consist of the removal and disposal of all stumps and roots and other debris, hereinafter referred to as debris.

202.02 Construction Method

Environmental protection measures shall be installed if possible prior to beginning any excavation. Otherwise, materials for environmental protection measures shall be on-site prior to excavation work and shall be installed at the earliest appropriate opportunity. All work carried out under this Section shall be done in accordance with the Environmental Requirements of Appendix 2.

Grubbing shall be carried out for a distance of not more than 1 km ahead of grading operations. The work shall consist of grubbing within the right-of-way and other areas as designated by the Engineer. Areas to be grubbed shall be marked or staked by the Engineer prior to grubbing.

Grubbing will not be required under embankments of 2 m or more.

Debris shall become the property of the Contractor, and shall be disposed of at the Contractor's own expense. Application for and acquisition of, relevant permits, permission from landowners and compliance with applicable laws, regulations and codes shall be the responsibility of the Contractor. A copy of any documents related to the foregoing shall be forwarded to the Engineer.

202.03 Method of Measurement

The quantity to be measured under this Section shall be the number of hectares actually grubbed.

202.04 Basis of Payment

Grubbing shall be paid at the unit bid price per hectare derived from measurements made by the Engineer of the designated and actually grubbed areas. All tools, machines, labour and incidentals shall be fully compensated for in the unit bid price for grubbing.



**GENERAL PROVISIONS AND CONTRACT SPECIFICATIONS  
FOR HIGHWAY CONSTRUCTION**

DEPARTMENT OF TRANSPORTATION AND PUBLIC WORKS

---

**EXCAVATION**

**203**

203.01 Description

This work consists of excavating materials within the Contract limits. Included would be the hauling and placement of suitable material within the Contract limits, the hauling and stockpiling (on-site) of surplus material for future use, and the hauling and disposal of waste material. This work is to be undertaken in accordance with Section 104.14

203.02 Classification of Excavated Materials

All excavated materials shall be classified for purposes of payment as rock, muck, earth or pavement as described herein. All decisions concerning classification of excavated material will be made by the Engineer.

203.02.01 Rock Excavation

Material classified as rock shall include material excavated from solid masses or ledges of igneous, sedimentary or metamorphic rock in their original or stratified bed or position and all boulders and detached fragments which measure one (1) m<sup>3</sup> or more in volume.

203.02.02 Muck Excavation

Material classified as muck may include bog and underlying material, tree stumps, roots and/or organic matter. Muck shall be in a saturated, flowable state, high in silt or clay content, requiring a water tight truck box to haul the material preventing drainage unto the haul road.

203.02.03 Pavement Excavation

Material classified as pavement shall be asphaltic concrete, Portland cement concrete and Portland cement stabilized soil (i.e. soil cement), which may occur in a layer or in combinations of layers.

203.02.04 Common Earth Excavation

Material classified as common earth excavation shall include all other materials of whatsoever nature that may not be defined as rock, muck or pavement. This classification of material shall apply to all roadway and drainage construction work except culverts, storm sewers and other underground pipe or conduit.

203.02.05 Earth Excavation for Pipe

Material classified as earth excavation for pipe shall include all other materials of whatsoever nature that may not be defined as rock, muck or pavement which result from the installation or replacement of roadway culverts or drain tile.

203.03 Construction Method

Prior to carrying out any work, the Contractor shall locate all underground services and shall take all necessary precautions to mitigate damage.

**GENERAL PROVISIONS AND CONTRACT SPECIFICATIONS  
FOR HIGHWAY CONSTRUCTION**

DEPARTMENT OF TRANSPORTATION AND PUBLIC WORKS

---

**EXCAVATION**

**203**

Environmental protection measures shall be installed, if possible, prior to beginning any excavation. Otherwise, materials for environmental protection measures shall be on-site prior to excavation work and shall be installed at the earliest appropriate opportunity. All work carried out under this Section shall be done in accordance with Environmental Requirements of Appendix 2.

The Contractor shall not excavate materials until cross-section measurements necessary to satisfy Provision 203.04 have been taken.

The Contractor shall perform all excavation operations in such a manner that flooding of embankment materials and roadway foundation materials is avoided; either by providing effective surface drainage during all stages of the work or in the case of sub-excavation and stripping operations, where provision for surface drainage is not feasible, by placing backfill material as soon as practical after excavation.

All materials that are to be incorporated in the work may be subject to testing by the Engineer to determine suitability for use.

The Contractor shall consult with the Engineer for instruction regarding use of excavated materials which may be incorporated in the work, disposed of due to poor quality or stockpiled to be used for other work. The Engineer shall determine what material is waste, and the Contractor shall dispose of it in an environmentally acceptable manner.

When embankments less than 2 m in height are to be built, the Contractor shall first strip unsuitable materials from the foundation area.

Should the Contractor excavate to a depth greater than provided for in this Provision, the Contractor shall be required to backfill such excavations at the Contractor's own expense and no payment shall be made for the backfill material or work required.

All excavated material used in the construction of the roadway shall be spread in uniform layers not exceeding 200 mm in thickness over the full width of the embankment. Embankments shall be constructed such that the first lift, when sloped, forms the toe of the slopes and each subsequent lift shall be completed to the full width prior to placing the next lift. Rock and rock fragments shall be uniformly distributed and broken to a maximum size of 100 mm. Each layer shall be shaped to the design cross-section and shall be thoroughly compacted in accordance with Section 209 to 95% Standard Proctor Density.

Grading of excavated materials shall be performed within a tolerance of 25 mm.

Excavations which are potentially hazardous to the travelling public shall not proceed more than 300 m in advance of the backfilling operation; such excavations shall be backfilled with the specified material and compacted prior to closing down operations each day.

**203.04 Method of Measurement**

The quantity to be paid for under this Section shall be the number of cubic metres of excavated material as shown on the cross-section sheets between the original position of the ground lines as cross-sectioned and the lines of the completed and accepted excavation as computed by

**GENERAL PROVISIONS AND CONTRACT SPECIFICATIONS  
FOR HIGHWAY CONSTRUCTION**

DEPARTMENT OF TRANSPORTATION AND PUBLIC WORKS

---

**EXCAVATION**

**203**

the average end area method. Whenever material is to be excavated, the Contractor shall notify the Engineer so that proper measurements or cross-sections can be made. No allowance will be made for material excavated before such measurements or cross-sections have been made. No allowance for excavated material will be made beyond the slope lines as indicated on the Plans or as directed by the Engineer.

203.05 Basis of Payment

The measured volume of excavation shall be paid for at the unit bid price per cubic metre for excavation of rock, muck, pavement or earth material as the case may be, and this price shall be full compensation for all the work including hauling and disposal of waste materials, hauling and stockpiling of surplus material, hauling and placement of suitable material, including compaction, equipment, tools, labour, water for compaction and incidentals necessary to complete the work.

203.02.04 Common Earth Excavation shall be divided into two payment line items:

Common Earth Excavation: suitable/surplus - hauling and placement of suitable material and/or the hauling and stockpiling (on-site) of surplus material for future use, and  
Common Earth Excavation: waste - hauling and disposal of waste material.

Should the Contractor fail to demonstrate diligent care in locating and protecting underground services, all resulting repairs shall be the responsibility and the expense of the Contractor.

Topsoil removal and reinstatement shall be paid for under Section 204. Environmental protection measures shall be paid for in accordance with the Section for the type of environmental protection installed.

**GENERAL PROVISIONS AND CONTRACT SPECIFICATIONS  
FOR HIGHWAY CONSTRUCTION**

DEPARTMENT OF TRANSPORTATION AND PUBLIC WORKS

---

**TOPSOIL REMOVAL AND REINSTATEMENT**

**204**

204.01 Description

This work shall consist of the excavation, stockpiling and redistribution of topsoil and overburden as necessary.

204.02 Construction Method

Environmental protection measures shall be installed if possible prior to beginning any excavation. Otherwise, materials for environmental protection measures shall be on-site prior to excavation work and shall be installed at the earliest appropriate opportunity. All work carried out under this Section shall be done in accordance with the Environmental Requirements of Appendix 2.

The Contractor shall remove all topsoil and overburden to the depth specified by the Engineer and shall neatly and separately stockpile the material at a site approved by the Engineer.

After removal and stockpiling of topsoil and overburden, the Contractor shall ensure that no other material is added to the topsoil and overburden stockpiles.

When the material is to be replaced on adjacent land, the overburden and topsoil shall be spread in uniform layers. When the material is to be reinstated within the right-of-way, the Contractor shall place each layer to the depth determined by the Engineer.

Prior to reinstatement, the area shall be scarified, harrowed and cleared of all loose rocks and stones.

204.03 Method of Measurement

The quantity to be paid for under this Section shall be the number of cubic metres of topsoil and overburden actually removed and replaced. Typically, cross-section drawings will be prepared for computation by the average end area method. No allowance will be made for material removed prior to the measurement of the original cross-sections.

204.04 Basis of Payment

Topsoil removal and reinstatement shall be paid for at the unit bid price per cubic metre and this price shall be full compensation for all work, tools, equipment, labour and incidentals necessary to complete the work.

**GENERAL PROVISIONS AND CONTRACT SPECIFICATIONS  
FOR HIGHWAY CONSTRUCTION**

DEPARTMENT OF TRANSPORTATION AND PUBLIC WORKS

---

**BORROW FROM ADJACENT LAND**

**205**

205.01 Description

This work shall consist of the removal of borrow material from land adjacent to the work. Included would be the hauling and placement of suitable material for the construction of embankments within the contract limits, the hauling and stockpiling (on-site) of surplus material for future use, and the disposal of unsuitable or waste material.

205.02 Construction Method

Environmental protection measures shall be installed if possible prior to any excavation. Otherwise, materials for environmental protection measures shall be on-site prior to excavation work and shall be installed at the earliest appropriate opportunity. All work carried out under this Section shall be done in accordance with the Environmental Requirements of Appendix 2.

The Contractor shall enter into an agreement with the land owner authorizing the Contractor to excavate material from the land and, upon request, shall show proof of such an agreement.

The construction method shall be performed in accordance with Section 203 and as specified herein.

Topsoil and overburden shall be removed and reinstated in accordance with Section 204. The adjacent land shall be cross-sectioned prior to stripping of the topsoil and overburden and cross-sectioned again prior to the removal of any borrow material. The extent of the topsoil and overburden removal shall be limited by the right-of-way and a line perpendicular to the right-of-way of a minimum 10:1 slope projected from the design ditch grade to the surface unless otherwise specified by the Engineer.

Borrow material taken from adjacent land shall be approved by the Engineer prior to placement on the work and rejected material shall be considered as waste to be disposed of by the Contractor.

205.03 Method of Measurement

The quantity to be measured under this Section shall be the number of cubic metres of borrow material as shown on the cross-section sheets and as computed by the average end area method. No allowance will be made for material excavated before measurements or cross-sections have been made.

205.04 Basis of Payment

The measured volume of borrow from adjacent land shall be paid for at the unit bid price per cubic metre and this price shall be full compensation for all work, material, transportation, equipment, tools, labour, water for compaction and incidentals necessary to complete the work.

**GENERAL PROVISIONS AND CONTRACT SPECIFICATIONS  
FOR HIGHWAY CONSTRUCTION**

DEPARTMENT OF TRANSPORTATION AND PUBLIC WORKS

---

**BORROW FROM PIT**

**206**

206.01 Description

When sufficient quantities of material suitable for highway embankments are not obtainable from excavation within the right-of-way in accordance with Section 203 or from land adjacent to the work in accordance with Section 205, the Contractor shall provide borrow material from pits.

206.02 Material

Borrow material specified in the work shall be of the type indicated in Schedule C of the Tender according to the following:

All borrow that is to be incorporated in the work shall be subject to tests by the Engineer to determine its suitability. Such tests may involve chemical or physical analysis to determine the organic content, bearing capacity, density and stability. The Engineer reserves the right to reject any material based on the test results or on the basis of field performance.

206.02.01 Common Borrow

Common Borrow shall be non-plastic and free from lumps of clay or other deleterious material and shall have a maximum of 35% passing the 75  $\mu$ m Sieve. Regardless of the properties, use of common borrow shall be subject to the approval of the Engineer.

206.02.02 Select Borrow

Select Borrow shall be non-plastic, well graded, and composed of clean, uncoated particles free from lumps of clay or other deleterious material with a maximum particle size of 100 mm, and a maximum of 30% of the material passing the 4.75 mm Sieve shall pass the 75  $\mu$ m Sieve.

206.02.03 Premium Borrow

Premium Borrow shall be non-plastic, well graded, and composed of clean, uncoated particles free from lumps of clay and other deleterious material with a maximum particle size of 100 mm, and a maximum of 20% of the material passing the 4.75 mm Sieve shall pass the 75  $\mu$ m Sieve.

206.03 Construction Method

The Contractor, before entering any borrow pit site for operation purposes shall comply with Provision 104.15. All work carried out under this Section shall be done in accordance with the Environmental Requirements of Appendix 2.

The Contractor shall clear and grub borrow areas and shall remove and stockpile topsoil and overburden.

Where the borrow material is to be measured for payment by weight, the Contractor shall provide for weighing in accordance with Provision 107.03.

The Contractor shall ensure that the pit is excavated in such a manner as to avoid flooding of borrow material.

**GENERAL PROVISIONS AND CONTRACT SPECIFICATIONS  
FOR HIGHWAY CONSTRUCTION**

DEPARTMENT OF TRANSPORTATION AND PUBLIC WORKS

---

**BORROW FROM PIT**

**206**

All borrow used in the construction of the roadway shall be spread in uniform layers not exceeding 200 mm in thickness over the full width of the embankment. Embankments shall be constructed such that the first lift, when sloped, forms the toe of the slopes and each subsequent lift shall be completed to the full width prior to placing the next lift. Rock and rock fragments shall be uniformly distributed and broken to a maximum size of 100 mm. Each layer shall be shaped to the design cross-section and shall be thoroughly compacted in accordance with Section 209 to 95% of the Standard Proctor Density.

All completed embankments shall truly conform to the lines and grades given by the Engineer within a tolerance of 25 mm.

206.04 Method of Measurement

Measurement for payment under this Section shall be the number of cubic metres or tonnes of borrow. The units of measurement shall be as indicated in Schedule C of the Tender.

When borrow material is to be supplied by the cubic metre, the unit of measure for payment shall be by the volume of the truck box actually filled with borrow material.

Where borrow is to be measured for payment by weight, the quantity to be paid for under this Section shall be the number of tonnes of borrow material weighed in accordance with Provision 107.03.

206.05 Basis of Payment

Borrow from any pit, shall be paid for at the unit bid price per cubic metre or tonne and this price shall be full compensation for all work, royalty payments to land owners, crop damage, removal and stockpiling of topsoil and overburden, trimming of pit slopes, replacement of overburden and topsoil on the pit, all equipment, tools, labour and incidentals necessary to complete the work.

**GENERAL PROVISIONS AND CONTRACT SPECIFICATIONS  
FOR HIGHWAY CONSTRUCTION**

DEPARTMENT OF TRANSPORTATION AND PUBLIC WORKS

---

**GRANULAR BASE**

**207**

---

207.01 Description

This item shall consist of the supply and placement of aggregate to produce a granular base for the roadbed.

207.02 Material

The material to be supplied under this item shall be in accordance with Section 401 and shall be of the classification specified in the Tender.

207.03 Construction Method

The Contractor shall prepare the subgrade or sub-base to receive the granular base by scarifying, scrapping and compacting as necessary to conform to the lines and grades given by the Engineer, within a tolerance of 25 mm and to provide compaction to 95% Standard Proctor Density in accordance with Section 209.

The Contractor will be completely responsible for ensuring the aggregate supplied is consistent with respect to particle size distribution and all physical properties as specified in Section 401. The Engineer may reject material received and may refuse any production source if the material lacks consistency or is proven to perform poorly.

Aggregate supplied to the work shall not vary significantly in moisture content. Saturated aggregate will not be accepted for use in the work.

The Contractor shall provide for weighing of the gravel in accordance with Provision 107.03.

Placement of aggregate as granular base shall be within a tolerance of 25 mm to the lines and grades given by the Engineer. Notwithstanding the acceptable tolerance, work specified elsewhere may require more precise grading to ensure successful achievement of the work (i.e. pavements).

Unless specified elsewhere, all aggregate used in the construction of the granular base shall be spread in uniform layers not exceeding 200 mm in thickness over the full width of the roadway. Each layer shall be shaped to the design cross-section and shall be thoroughly compacted, in accordance with Section 209 to 100% Standard Proctor Density, prior to the placement of the next layer.

207.04 Method of Measurement

Measurement for payment under this Section shall be the number of cubic metres or tonnes of aggregate for granular base. The units of measurement shall be as indicated in Schedule C of the Tender.

When granular base material is to be supplied by the cubic metre, the unit of measure for payment shall be by the volume of the truck box actually filled with aggregate.

When granular base is specified by the tonne, the aggregate shall be weighed in accordance with Provision 107.03.



**GENERAL PROVISIONS AND CONTRACT SPECIFICATIONS  
FOR HIGHWAY CONSTRUCTION**

DEPARTMENT OF TRANSPORTATION AND PUBLIC WORKS

---

**GRANULAR BASE**

**207**

207.05 Basis of Payment

Granular base shall be paid for at the unit bid price per cubic metre or tonne and this price shall be full compensation for all work, aggregate, material, tools, equipment, labour and incidentals necessary to perform the work.

**GENERAL PROVISIONS AND CONTRACT SPECIFICATIONS  
FOR HIGHWAY CONSTRUCTION**

DEPARTMENT OF TRANSPORTATION AND PUBLIC WORKS

---

**FINE GRADING**

**208**

---

208.01 Description

Fine grading shall consist of shaping the roadway surface as shown on the contract Drawings or as directed by the Engineer, to a final cross-section and profile in preparation for paving.

208.02 Construction Method

The required widths and lengths of the roadway surface shall be scarified, unless otherwise directed by the Engineer, up to a depth of 150 mm to produce the specified grade and cross-section and shall be compacted in accordance with Section 209 to 100% Standard Proctor Density.

Where insufficient material is obtained in the scarifying or blading operation to bring the cross-section and grade to within the specified tolerance, the Contractor shall provide additional material as provided for elsewhere in the Contract and such material shall be placed to ensure homogeneity with the surrounding material.

The surface to be fine graded shall be to the width specified by the Engineer, but shall not be less than the width of the proposed pavement plus 500 mm on either side. The maximum acceptable deviation from grade at any location shall be 10 mm of that specified.

The shaping and compaction operations shall continue until the surface conforms to the specified requirements and shall be repeated as required to maintain the surface until it is covered by pavement.

208.03 Method of Measurement

The area of roadway surface actually fine graded as herein provided shall be measured for payment in square metres.

208.04 Basis of Payment

Fine grading shall be paid for at the unit bid price per square metre and this price shall be full compensation for all work, including scarifying and regrading, equipment, tools, labour, water for compaction and incidentals necessary to complete the work.

Payment for additional materials provided will be paid in accordance with the section for the type of material supplied.

**GENERAL PROVISIONS AND CONTRACT SPECIFICATIONS  
FOR HIGHWAY CONSTRUCTION**

DEPARTMENT OF TRANSPORTATION AND PUBLIC WORKS

---

**COMPACTION**

**209**

---

209.01 Description

This work shall consist of the compaction required on the subgrade, sub-base and base course materials.

209.02 Construction Method

The Contractor shall provide the necessary compaction equipment to achieve the required compaction.

The required compaction shall be indicated in the various specifications for supply and placement of material.

The test method to assure that the required density is achieved shall be ASTM D-698 for the supply and placement of all materials except for Granular A and B as defined in Section 401 which shall be AASHTO T-99 (Method A) and T-224.

The Contractor shall take appropriate measures to ensure that the moisture content of the subject material is appropriate to achieve the specified density. This may require reworking the material and air-drying or the application of water to the material.

209.04 Method of Measurement

There shall be no measurement for payment under this Section.

209.05 Basis of Payment

No payment shall apply to this Section.

Compaction shall be supplied and paid for according to the various specifications for sub-grade, sub-base and base materials.

**GENERAL PROVISIONS AND CONTRACT SPECIFICATIONS  
FOR HIGHWAY CONSTRUCTION**

DEPARTMENT OF TRANSPORTATION AND PUBLIC WORKS

---

**PREPARING SHOULDERS**

**210**

210.01 Description

This work shall consist of excavating unsuitable material from the unpaved shoulder to the bottom of the asphaltic concrete in preparation for placement of new shoulder material.

210.02 Construction Method

The Contractor shall excavate the existing unpaved shoulders to the lines and grades indicated by the Engineer. Surplus shoulder material shall be disposed of in accordance with Provision 104.14. The excavated surface shall be shaped to slope away from the pavement at a rate of 4% and shall be compacted in accordance to Section 209 to 95% of Standard Proctor Density.

Excavations shall not be left open overnight.

Waste material from the excavation shall be disposed of by the Contractor.

The allowable deviation from grade shall be 25 mm.

210.03 Method of Measurement

The quantity to be measured under this Section shall be the number of square metres of shoulders actually prepared.

210.04 Basis of Payment

---

Preparing shoulders shall be paid for at the unit bid price per square metre and this price shall be full compensation for excavation and disposal of material, grading, compaction, and tools, equipment, labour and incidentals necessary to complete the work.

**GENERAL PROVISIONS AND CONTRACT SPECIFICATIONS  
FOR HIGHWAY CONSTRUCTION**

DEPARTMENT OF TRANSPORTATION AND PUBLIC WORKS

---

**SHOULDER MATERIAL**

**211**

---

211.01 Description

This work shall consist of the supply and placement of aggregate, milled asphalt pavement, borrow or topsoil on the shoulders of the roadway.

211.02 Material

The material to be supplied under this Section shall be of the type specified in Schedule C of the Tender and shall be approved by the Engineer prior to placement.

Aggregate shall meet all specifications for the class specified in Section 401. Borrow material shall be in accordance with Sub-Provision 206.02.02 and Topsoil shall be in accordance with Section 212 with the additional requirement that 100% of both materials shall pass the 50 mm Sieve.

211.03 Construction Method

The Contractor shall prepare the shoulder, as provided for elsewhere in the Contract, and shall ensure that any debris has been removed.

Shoulder material shall be placed by a shouldering machine approved by the Engineer.

The Contractor shall produce a final graded surface having a uniform 4% cross-slope toward the ditch except on the outer edge of a super-elevated curve where the Contractor shall consult with the Engineer for direction.

Where shoulder material is to be placed after paving, compaction of aggregate and borrow shall be achieved using an appropriate rubber-tired roller in accordance with Section 209 to 95% of the Standard Proctor Density. The Engineer may approve the use of an alternative type of roller if safe operation of a rubber-tired roller can not be achieved. Topsoil shall be compacted to the satisfaction of the Engineer. Excess shoulder material shall be removed at the Contractor's own expense. All handwork required at driveways and intersecting roadways ,etc. must be completed immediately following the shouldering process or the liquidated damages shall come in to effect.

The Contractor shall sweep any excess material from the paved surface.

The Contractor shall be responsible for repairing to the satisfaction of the Engineer, at the Contractor's own expense, any damage caused to the paved surface by the shouldering operation.

**GENERAL PROVISIONS AND CONTRACT SPECIFICATIONS  
FOR HIGHWAY CONSTRUCTION**

DEPARTMENT OF TRANSPORTATION AND PUBLIC WORKS

---

**SHOULDER MATERIAL**

**211**

211.04 Scheduling and Liquidated Damages

Shoulder material placement shall commence:

- (i) for a one year project: no later than four days after each individual section was ready for shouldering. (Section : length of roadway paved in one day)
- (ii) for a multiple year project: no later than four days after each individual section was ready for shouldering each year.

All shoulder material shall be placed no later than four days after the completion of the final lift of asphalt in each year. Liquidated damages of \$300.00 per day shall be assessed for each day beyond 4 days after the asphalt paving is completed. This shall apply regardless of whether paved shoulders exist.

211.05 Method of Measurement

The quantity to be measured under this Section shall be the number of tonnes of shoulder material placed.

211.06 Basis of Payment

Shoulder material shall be paid for at the unit bid price per tonne for supply and placement of shoulder material and this price shall be full compensation for all work, royalty payments to land owner, equipment, tools, labour and incidentals necessary to complete the work.

**GENERAL PROVISIONS AND CONTRACT SPECIFICATIONS  
FOR HIGHWAY CONSTRUCTION**

DEPARTMENT OF TRANSPORTATION AND PUBLIC WORKS

---

**TOPSOIL**

**212**

---

212.01 Description

This work shall consist of the supply and placement of topsoil for in areas designated by the Engineer.

212.02 Material

Topsoil shall be a fertile, friable, loamy soil. Topsoil shall not contain excessive amounts of roots, stones, sods, clods or other foreign matter. The Engineer shall accept or reject topsoil based on the overall quality of the material.

212.03 Construction Method

Areas to be landscaped with topsoil shall be scarified or tilled to a depth of 50 mm and then uniformly graded such that after topsoil placement the areas shall blend in with the adjoining topography.

Topsoil shall be spread on the prepared areas to a uniform depth of 100 mm unless otherwise directed. Stones and all other deleterious materials shall be removed to the satisfaction of the Engineer. The final product shall be considered landscaped and ready for seeding.

The Contractor shall perform a cleanup of excess topsoil spilled outside of the areas designated for landscaping.

212.04 Method of Measurement

The quantity to be measured for payment under this Section shall be the number of tonnes, in accordance with Provision 107.03, or the number of cubic metres by truck box measure.

212.05 Basis of Payment

Topsoil shall be paid for at the unit bid price per tonne or cubic metre and this price shall be full compensation for the supply of topsoil, and all work associated with landscaping, scarifying, tilling, grading, land levelling, raking, tools, equipment, labour and incidentals necessary to complete the work.

**GENERAL PROVISIONS AND CONTRACT SPECIFICATIONS  
FOR HIGHWAY CONSTRUCTION**

DEPARTMENT OF TRANSPORTATION AND PUBLIC WORKS

---

**RANDOM RIP RAP**

**213**

---

213.01 Description

This item consists of the supply and placement of Class 1 and Class 2 random rip rap in accordance with the plans or as directed by the Engineer.

213.02 Material

Materials shall be supplied by the Contractor after being approved by the Engineer. The Engineer shall be notified of rip rap sources in writing at least 14 days prior to the Contractor obtaining material. The rock shall be free of splits, seams, laminations, weak cleavages or defects likely to impair its soundness during handling and placing or result in undesirable weathering and disintegration from the action of air, water and ice. Any Rip Rap with features such as seams, joints, lenses and bands of similar or different lithological material that tend to form planes of weakness along which the stone material breaks or separates shall be rejected. Random rip rap material supplied under this item shall be a well-graded mixture and shall meet the gradation sizes as specified in Table 213-1. The least dimension of any rock shall not be less than one half of the greatest dimension. In addition, random rip rap shall satisfy the following physical requirements:

Class 1 - Class 1 random rip rap shall consist of clean hard, durable quarried stone having a density of not less than 2.6 tonne/m<sup>3</sup> and a maximum petrographic number of 150. The rock material, if subjected to the Los Angeles Abrasion Test (ASTM C131), shall have a loss not greater than 35%. When tested for soundness, five cycles of magnesium sulphate (ASTM C88), the rock material shall have a loss not greater than 15%. Sandstone rock will not be acceptable for use as Class 1 random rip rap.

Class 2 - Class 2 random rip rap shall consist of clean, hard, durable field or quarry stone free of overburden and organic soil and approved for use by the Engineer. Rock with visible planes of weakness and/or subject to distinct deterioration by water or weather will not be accepted.

The contractor shall always use Class 1 random rip rap unless otherwise specified.

213.03 Construction Method

The Contractor shall provide for the weighing of random laid rip rap material in accordance with Provision 107.03. Before placing random rip rap, grades and slopes of underlying material shall be shaped as shown on the Plans or as directed by the Engineer. Random rip rap shall be placed in areas shown on the plans or as directed by the Engineer. The random rip rap shall be placed by procedures and equipment approved by the Engineer until specified dimensions are obtained. No pushing of the stones by bulldozers or other equipment will be allowed.

The random rip rap shall be placed in such a manner that underlying slopes are not disturbed and material is not wasted. The rip rap shall be placed such that each rock is stable, secure and supported by rocks below and the placement shall be controlled to ensure that a uniform and continuous cover is achieved. When random rip rap is placed on top of a geotextile, the Contractor shall take due care to prevent damage to the geotextile material.



**GENERAL PROVISIONS AND CONTRACT SPECIFICATIONS  
FOR HIGHWAY CONSTRUCTION**

DEPARTMENT OF TRANSPORTATION AND PUBLIC WORKS

---

**RANDOM RIP RAP**

**213**

---

213.04 Quality Control/Quality Assurance

The acceptability of the rock for use shall be determined based on available service records and/or laboratory/field test results. Any additional prequalification testing shall be carried out at the discretion of the Engineer. Control of gradation of material as delivered to the site shall be by visual examination. Any difference in opinion between the Engineer and the Contractor shall be resolved by testing carried out by qualified personnel in accordance with ASTM D5519 Test Method A. The Contractor shall provide the equipment, a sorting site and any labour required to undertake such testing.

The cost associated with any required prequalification testing shall be borne by the Contractor. The cost of the provision of materials, labour and equipment to resolve disagreement between the Owner and the Contractor shall be borne by the Contractor if the test results show that the material does not conform to the specified gradation, otherwise the Owner shall bear the cost of the testing. The cost of any retesting to resolve the supply of the specified material gradation shall be borne by the Contractor.

213.05 Method of Measurement

Measurement for payment of random rip rap shall only include material supplied and placed in accordance with the provisions of this Section and acceptable to the Engineer.

The quantity to be measured under this Section shall be the acceptable number of tonnes of random rip rap weighed in accordance with Provision 107.03.

213.06 Basis of Payment

Random rip rap material shall be paid for at the unit bid price per tonne and this price shall be full compensation for hauling, shaping of underlying material, equipment, tools, labour and incidentals necessary to complete the work.

**GENERAL PROVISIONS AND CONTRACT SPECIFICATIONS  
FOR HIGHWAY CONSTRUCTION**

DEPARTMENT OF TRANSPORTATION AND PUBLIC WORKS

**RANDOM RIP RAP**

**213**

**Table 213-1 Random Rip Rap Gradation**

Size (mm)	Finer by Mass (%)						
	R-5	R-25	R-50	R-100	R-250	R-500	R-1000
1300	-	-	-	-	-	-	100
1100	-	-	-	-	-	-	70-90
1000	-	-	-	-	-	100	-
900	-	-	-	-	-	70-90	40-55
820	-	-	-	-	100	-	-
710	-	-	-	-	70-90	40-50	-
600	-	-	-	100	-	-	-
570	-	-	-	-	40-55	-	-
530	-	-	-	70-90	-	-	-
480	-	-	100	-	-	-	-
420	-	-	70-90	40-55	-	-	0-3
380	-	100	-	-	-	-	-
330	-	70-90	40-55	-	-	0-3	-
260	-	40-55	-	-	0-3	-	-
220	100	-	-	-	-	-	-
190	70-90	-	-	0-3	-	-	-
150	40-55	-	0-3	-	-	-	-
120	-	0-3	-	-	-	-	-
75	0-3	-	-	-	-	-	-
<b>Thickness<sup>(1)</sup> (mm)</b>	<b>300</b>	<b>500</b>	<b>600</b>	<b>800</b>	<b>1100</b>	<b>1400</b>	<b>1600</b>

- (1) Measured perpendicular to the prepared surface
- (2) The titles R-5, R-25, etc. refer to minimum average mass in Kg.

**GENERAL PROVISIONS AND CONTRACT SPECIFICATIONS  
FOR HIGHWAY CONSTRUCTION**

DEPARTMENT OF TRANSPORTATION AND PUBLIC WORKS

---

**TAP DRAIN INSTALLATION**

**214**

214.01 Description

This work shall consist of construction of diversion ditches outside of the roadway, hereafter referred to as tap drains.

214.02 Construction Method

Environmental protection measures shall be installed, if possible, prior to beginning any excavation. Otherwise, materials for environmental protection measures shall be on-site prior to excavation work and shall be installed at the earliest appropriate opportunity. All work carried out under this Section shall be done in accordance with the Environmental Requirements of Appendix 2.

The Engineer shall lay out the line and grade of the tap drain prior to excavation. The tap drain shall be constructed to have a minimum 1 m wide flat bottom and side slopes not steeper than 1:2 unless otherwise directed by the Engineer.

Clearing, grubbing and topsoil removal and reinstatement, as required, shall be performed in accordance with the respective Provisions 201.02, 202.02 and 204.02.

Straw or hay mulch shall be supplied and placed on all bare soil surfaces on a daily basis.

Excavated material deemed as surplus may be reused or stockpiled for future use. The Contractor shall transport this material within the job site to a location indicated by the Engineer.

Excavated material deemed as waste shall be disposed of in accordance with Provision 104.14.

214.03 Method of Measurement

The quantity to be measured for tap drain construction shall be the number of linear metres of tap drain constructed.

214.04 Basis of Payment

Payment under this Section shall be at the unit bid price per linear metre and this price shall be full compensation for all work, clearing, grubbing, excavation, stockpiling, and topsoil removal and reinstatement, equipment, labour and incidentals necessary to perform the work.

**GENERAL PROVISIONS AND CONTRACT SPECIFICATIONS  
FOR HIGHWAY CONSTRUCTION**

DEPARTMENT OF TRANSPORTATION AND PUBLIC WORKS

---

**DITCHING**

**215**

215.01 Description

This work shall consist of excavating and regrading the existing ditch within the roadway, and removing sediment build-up around inlets and outlets of roadway and driveway culverts located within the limits of the work.

215.02 Construction Method

Environmental protection measures shall be installed, if possible, prior to beginning any excavation. Otherwise, materials for environmental protection measures shall be on-site prior to excavation work and shall be installed at the earliest appropriate opportunity. All work carried out under this Section shall be done in accordance with the Environmental Requirements of Appendix 2.

The excavation shall proceed in the upstream direction.

The ditch shall be reshaped to have a 1 m wide flat bottom with side slopes not steeper than 2:1. In cases where the available right-of-way is insufficient in width to achieve the desired cross-section, the Engineer shall direct the Contractor on a case specific basis.

Immediately upon completion of the ditching or, as a minimum, at the end of the day, and if so directed by the Engineer disturbed slope areas within 10m of a culvert shall be stabilized as indicated in Section 312 - Culvert End Treatment.

Straw or hay mulch shall be supplied and placed on all bare soil surfaces as required by the Engineer.

Excavated material deemed as surplus may be reused or stockpiled for future use. The Contractor shall transport this material within the job site to a location indicated by the Engineer. Excavated material deemed as waste shall be disposed of in accordance with Provision 104.14.

215.03 Method of Measurement

Measurement for payment under this Section shall be the number of linear metres of ditch reshaped.

No measurement for payment will be made under this section for culvert end treatments but shall be made under Section 312.

215.04 Basis of Payment

Payment under this Section shall be at the unit bid price per linear metre and this price shall be full compensation for all work including excavation, tools, labour, equipment and incidentals necessary to perform the work.

Payment for culvert end treatments shall be in accordance with Section 312.

Payment for environmental protection measures shall be paid for in accordance with the section for the type of protection required.

**GENERAL PROVISIONS AND CONTRACT SPECIFICATIONS  
FOR HIGHWAY CONSTRUCTION**

DEPARTMENT OF TRANSPORTATION AND PUBLIC WORKS

---

**CULVERT END CLEANOUT**

**216**

216.01 Description

The work to be carried out under this Section involves excavation of earth build-up near the ends of drainage culverts. This item is essentially a maintenance measure designed to correct accumulated sediment build-up from local sources of soil erosion

216.02 Construction Method

The Contractor shall excavate excess material from within the ditch and culvert using appropriate hand and power tools. Handwork shall be required in many cases to avoid damage to the culverts.

The Contractor shall dig a sump at the downstream end of the culvert.

Sediment or rock deposits inside the culvert shall be removed.

Damage to culverts as a result of this work shall be repaired to the satisfaction of the Engineer at the expense of the Contractor.

Upon completion, the original ditch profile and cross-section shall be restored to allow unobstructed drainage and the transition to the existing ditch shall be smooth.

The Engineer may specify a location within the job for surplus material to be deposited for re-use; if not re-used, waste material shall be disposed of by the Contractor.

Excavation under this Section shall not exceed 10 m in length at any culvert end.

Immediately upon completion of the culvert end clean out extension or, as a minimum, at the end of the work day, disturbed slope areas within 10m of the culvert shall be stabilized as indicated in Section 312 - Culvert End Treatment.

216.03 Method of Measurement

The quantity to be measured for payment under this Section shall be the number of culvert ends improved.

No measurement for payment will be made under this section for culvert end treatments but shall be made under Section 312.

216.04 Basis of Payment

Payment under this Section shall be at the unit bid price per culvert end improved and this price shall be full compensation for all work, tools, labour, equipment and incidentals necessary to perform the work.

Payment for culvert end treatments shall be in accordance with Section 312.

Payment for Random Rip Rap shall be in accordance with Section 213.

**GENERAL PROVISIONS AND CONTRACT SPECIFICATIONS  
FOR HIGHWAY CONSTRUCTION**

DEPARTMENT OF TRANSPORTATION AND PUBLIC WORKS

---

**TRENCH EXCAVATION AND BACKFILLING**

**217**

---

217.01 Scope

This Section specifies the requirements to perform excavation of all types of material, to dispose of unsuitable and surplus material, to place bedding material, to place excavated material as backfill, and to furnish backfill material.

The work generally includes, but is not necessarily limited to the following items:

- Trench excavation and backfilling for pipelines, conduits and appurtenances.
- Structure excavation and backfilling for manholes, catch basins, chambers, signal pole bases and controller cabinet bases.
- Supply and placement of bedding material.
- Control of water in trench excavations by de-watering.
- Removal and disposal of surplus and/or unsuitable material.
- Sheet piling, shoring, trench boxes and bracing to support trench walls, sides of excavations, existing structures or utilities.

217.02 Existing Structures and Underground Services

Furnish temporary support, adequate protection and maintenance for all underground and surface structures, drains, forcemains, water systems, sewers, trees, utility poles and other obstructions under the direction of the Engineer.

Restore, upon completion of the work, structures which have been disturbed.

Wherever obstructions not shown on Drawings are encountered that interfere with the work, the Engineer shall have the authority to change the Drawings and order a deviation from the line and grade or arrange with the owner to remove, relocate and reconstruct the obstructing structure. The Contractor shall have no claim for any delays resulting from unforeseen obstructions encountered during the progress of the work.

The Contractor shall proceed with caution in excavation and preparation of trenches so that the exact location of all buried pipes and services and underground structures may be determined. The Contractor shall be responsible for any repair of pipes, services and structures, when broken or otherwise damaged.

During the work, the Contractor shall not unreasonably interfere with flow of sewage or water in any existing sewer or drain nor jeopardize public health in any way. Wherever a sanitary sewer is pumped or diverted, it shall be carried entirely in closed pipes. Temporary diversion of sanitary sewerage through an open channel shall not be permitted.

Whenever it is necessary to explore and excavate to determine the location of existing underground utilities, it shall be at the Contractor's own expense.

217.03 Support of Excavation

**GENERAL PROVISIONS AND CONTRACT SPECIFICATIONS  
FOR HIGHWAY CONSTRUCTION**

DEPARTMENT OF TRANSPORTATION AND PUBLIC WORKS

---

**TRENCH EXCAVATION AND BACKFILLING**

**217**

---

Suitably slope or properly shore sides of excavations according to site conditions and use support where necessary.

The choice of any method of support shall be the responsibility of the Contractor; however, drawings and calculations for the method of support, designed by a qualified professional Engineer in accordance with the Provincial Safety Requirements, are to be submitted to the Engineer for approval.

If it is desirable that any support, other than that which may be shown on the Drawings, be left in the excavations, then the Engineer will issue instructions accordingly.

Every precaution shall be taken against slips or falls; if a slip or fall occurs the Contractor shall execute remedial work, as the Engineer considers necessary, including filling with approved granular material.

217.04 Material

Select backfill material: approved material from site excavation. Such material shall be free from stumps, trees, roots, sod, muck or other deleterious material, and shall not contain rock, boulders or masonry larger than 150 mm in diameter. The material shall be free from frost and it shall not be placed on frozen ground or in water.

Bedding material shall be the class specified, in accordance with Sections 401 and 402.

217.05 Construction Method - General

Compute amounts and nature of excavation required and excavate all materials encountered on the work site.

Protect property or structures above or below ground.

Where excavation is to be performed through existing pavement, cut pavement in accordance with Section 710.

Found excavated surfaces on solid undisturbed ground. If the excavated surface, is unsuitable, the Engineer will determine what work is required to secure a proper foundation. If such work is due solely to the nature of the ground, then the Engineer will measure the work, but if such work is due to any act or default of the Contractor resulting in disturbance of natural ground conditions, then the Contractor shall execute the work at no additional cost to the Contract.

Any excavation to a depth greater than shown on the Drawings shall be at no additional cost to the Contract, unless ordered by the Engineer. Make good trench bottoms with approved granular material adequately compacted, as approved by the Engineer, or with concrete as may be necessary for the safety or stability of the work.

Pile excavated material so it will not endanger personnel or the work, reduce sight distances or obstruct roadways.

Leave utility controls unobstructed and accessible at all times.

Do not obstruct drainage ditches or natural watercourses.

**GENERAL PROVISIONS AND CONTRACT SPECIFICATIONS  
FOR HIGHWAY CONSTRUCTION**

DEPARTMENT OF TRANSPORTATION AND PUBLIC WORKS

---

**TRENCH EXCAVATION AND BACKFILLING**

**217**

---

Remove all waste material, with the Engineer's approval, from the site at no additional cost to the Contract.

The Engineer reserves the right to re-use surplus material for embanking, general grading or other improvements or uses on site.

Control grading so that the surface of the ground will be properly sloped to prevent water from running into excavated areas.

217.05.01      Draining, Pumping and Thawing

Keep all excavations and trenches free of water at all times. Control excavations to prevent surface water running into excavated areas and promptly remove any accumulated water.

Supply and maintain pumps, in number and capacity sufficient to keep all excavations dry and free from water at all times. Operate all equipment for as long as necessary.

Dispose of water removed from excavations in a manner that will prevent damage to public health, private property or the work. Pumping of water containing silt or other suspended material into streams or drainage courses is prohibited.

Ensure that all sub-drains, sump holes, wells or the like do not endanger the stability of the work. On completion of the work completely backfill and consolidate any excavations.

Excavate, remove or thaw out frozen ground as necessary.

217.05.02      Structure Excavation

Extend excavations a sufficient distance from foundations to allow the placement and removal of forms, installation of services and inspection.

217.05.03      Trench Excavation

Trenches for piping and related excavations shall be of sufficient width and depth at all points to allow pipes to be laid, joints to be formed and appurtenant structures to be built. When needed, allow for sheeting and shoring, pumping, draining and removal and replacement of materials unsuitable for foundations.

Excavate trenches so pipe can be laid to the alignment and depth required. Excavate only so far in advance of pipe laying as permitted by the Engineer; in most cases this shall be only what can be backfilled in the same day. Brace and drain trench so workmen can work safely and efficiently.

Remove all organic material and soft deposits until medium dense to dense materials are encountered or to a depth as specified by the Engineer.

Do not stockpile excavated materials alongside trenches if the bearing soil will cause trench side failure or bottom uplift.

217.05.04      Bedding - General

Bear foundations of all structures including pipe surrounds on 150 mm granular bedding material unless otherwise shown on the Drawings. The bedding material shall be compacted



**GENERAL PROVISIONS AND CONTRACT SPECIFICATIONS  
FOR HIGHWAY CONSTRUCTION**

DEPARTMENT OF TRANSPORTATION AND PUBLIC WORKS

---

**TRENCH EXCAVATION AND BACKFILLING**

**217**

---

to 95% Standard Proctor Density except when under existing or proposed asphalt which shall be compacted to 100% Standard Proctor Density in accordance with Section 209. In confined areas of the excavation, bedding shall be compacted using suitable hand or plate tampers. Neatly finish all bearing surfaces to the required levels and grades.

217.05.05 Backfilling - General

After pipelines and structures have been built, backfill trenches and other excavated areas as specified with materials shown on the Drawings. Remove all timber and debris from excavations before backfilling. Do not cover or put out of view any work until it has been examined, approved and measured by the Engineer. If any work is covered without approval of the Engineer, it must be uncovered for examination.

Any stones greater than 100 mm shall not be placed within 300 mm of the structure or pipe.

217.05.06 Backfilling Structures

After installation of structures and after authority to proceed, backfill excavations using select backfill material.

Place backfill in horizontal layers not more than 200 mm deep.

Compact each layer to obtain a density of not less than 100% Standard Proctor Density in accordance with Section 209.

Bring backfill up evenly on all sides to a suitable elevation above grade to allow anticipated settlement.

217.05.07 Backfilling Trenches

Backfill trench from top of bedding to top of subgrade using materials shown on the Drawings.

Place backfill in 200 mm layers and compact in accordance with Section 209 to 95% Standard Proctor Density with the exception of under existing or proposed asphalt which shall be compacted in accordance with Section 209 to 100% Standard Proctor Density.

During backfilling, keep trenches free of water at all times and control water to prevent surface water from running into excavated areas. Remove any silty materials which become wetted and subsequently liquid or extremely plastic.

Leave surfaces of backfill initially high and make good any settlement of trench backfilling.

217.06 Method of Measurement

There shall be no measurement for payment under this Section.

217.07 Basis of Payment

No payment shall apply to this Section.

**GENERAL PROVISIONS AND CONTRACT SPECIFICATIONS  
FOR HIGHWAY CONSTRUCTION**

DEPARTMENT OF TRANSPORTATION AND PUBLIC WORKS

---

**GEOTECHNICAL FABRIC**

**218**

---

218.01 Description

This work involves supplying and placing of geotechnical fabric to be used as a separation layer between successive layers of distinct materials.

218.02 Material

The plastic yarn of the geotechnical fabric and the threads used in sewing operations shall consist of a long chain synthetic polymer composed of at least 85% by mass of propylene, ethylene, ester, amide or vinylidene-chloride, and shall consist of stabilizers or inhibitors added to the base plastic to make the filaments resistant to deterioration by ultraviolet and heat exposure.

Type N1, N2, N3 and N4 fabric shall be a previous sheet of non-woven plastic yarn.

Type W1 and W2 fabric shall be a sheet of woven plastic yarn.

The geotechnical fabric shall conform to the requirements as listed in Table 218-1

The material shall be handled and protected as per the manufacturer's instructions and recommendations, until incorporated into the work.

The Contractor shall submit in advance of the work a mill certificate for the geotechnical fabric to be supplied, as well as the manufacturer's recommended procedures for installation and instructions for handling of the selected geotextile.

218.03 Construction Method

The Contractor shall carry out the work as indicated in the contract documents and/or as directed by the Engineer.

Install geotechnical fabric on a surface that has no stumps, brush, limbs or other material that may tear or puncture the fabric.

The fabric shall be layered in accordance with the manufacturer's recommendations.

Fabric that is damaged shall be replaced immediately.

218.04 Method of Measurement

The quantity to be measured under this Section shall be the area in square metres of geotechnical filter fabric placed.

218.05 Basis of Payment

Payment for the work under this Section shall be the unit bid price per square metre for each type of geotechnical fabric supplied and installed. It shall be the full compensation for the material, the cost, the labour, tools, equipment and incidentals necessary to complete the work.

**GENERAL PROVISIONS AND CONTRACT SPECIFICATIONS  
FOR HIGHWAY CONSTRUCTION**

DEPARTMENT OF TRANSPORTATION AND PUBLIC WORKS

**GEOTECHNICAL FABRIC**

**218**

**Table 218-1 Requirements of Non-Woven and Woven Geotechnical Fabrics**

Type of Fabric

<b>Property (Note 1)</b>	<b>Unit</b>	<b>ASTM</b>	<b>N1</b>	<b>N2</b>	<b>N3</b>	<b>N4</b>	<b>W1</b>	<b>W2</b>
Mullen Burst Strength	kPa	D3786	1100	1600	2200	3800	1500	3500
Tearing Strength (Trapezoid Method)	N	D4533	160	250	310	500	200	500
Grab Tensile Strength (Both Directions)	N	D4632	400	600	790	1200	400	1200
Elongation At Break	%	D4632	50	50	50	50	25 max.	25 max.
Apparent Opening Size	µm	D4751	50 to 250	50 to 250	50 to 250	50 to 250	840 max.	Note 2
UV Degradation	% Ret.	D4355					70 min.	Note 2
Permittivity	Sec <sup>-1</sup>	D4491	1.75 to 3.50	1.25 to 2.75	1.00 to 2.50	0.50 to 2.50	0.01 min.	Note 2
Thickness	mm						2.5 min.	

Note 1 Values above the heavy line are Minimum Average Roll Values (MARV)

Note 2 Special Requirement defined in the Contract Documents

**GENERAL PROVISIONS AND CONTRACT SPECIFICATIONS  
FOR HIGHWAY CONSTRUCTION**

DEPARTMENT OF TRANSPORTATION AND PUBLIC WORKS

**GEOGRID REINFORCEMENT**

**219**

219.01 Description

This work includes the supply and placement of geogrid which will serve to strengthen the roadbed.

219.02 Material

Geogrid to be BX1100 (BR1) or BX1200 (BR2) as manufactured by Tensar or equivalent in terms of physical properties and strength.

The geogrid shall be a biaxially formed regular grid structure; resistant to ultra-violet degradation, to damage under normal construction practices, and to all forms of biological or chemical degradation normally encountered in the material being reinforced. It shall also have the characteristics outlined in Table 219-1.

**Table 219-1 Requirements for Geogrid Reinforcement**

<b>Property</b>	<b>Type 1 Minimum</b>	<b>Type 2 Minimum</b>	<b>Test</b>
Aperture Stability Modulus at 20cm-kg ((cm-kg)/deg)	3.2	6.5	Kinney - 01
Aperture Size along Roll Length (mm)	25	25	Calipered
Open Area (%)	70		Calipered
Rib Thickness at Ribs (mm)	0.76	1.27	Calipered
Polypropylene Material (%)	98	98	ASTM D-4101
Carbon Black Material (%)	0.5	0.5	ASTM D-4218
Flexural Rigidity along Roll Length (mg/cm)	250,000	750,000	ASTM D-1388
Tensile Modulus (kg/m)	20,835		
Strength at Junctions (kg/m)	1,116		GRI GG2
Minimum True Initial Modulus in Use (kN/m) - MD	226	360	ASTM D-6637
Minimum True Initial Modulus in Use (kN/m) - CMD	481	652	ASTM D-6637
Efficiency of Junctions (%)	90	90	GRI GG2

**GENERAL PROVISIONS AND CONTRACT SPECIFICATIONS  
FOR HIGHWAY CONSTRUCTION**

DEPARTMENT OF TRANSPORTATION AND PUBLIC WORKS

---

**GEOGRID REINFORCEMENT**

**219**

219.03 Construction Method

The Contractor shall supply material in standard rolls for general application where designated by the Engineer.

The geogrid shall be laid on the prepared surface as indicated on the contract Drawings or as directed by the Engineer.

Geogrid shall be laid in accordance with manufacturer's recommendations. Cut and overlap geogrid to accommodate curves, underground structures and other protrusions. Secure geogrid to prevent separation and to provide anchorage in accordance with manufacturer's recommendations.

219.04 Method of Measurement

The quantity to be measured under this Section shall be the number of square metres of geogrid actually used.

219.05 Basis of Payment

Geogrid shall be paid for at the unit bid price per square metre and this price shall be full compensation for the material, the work, labour, tools, equipment and other incidentals necessary to complete the work.

**GENERAL PROVISIONS AND CONTRACT SPECIFICATIONS  
FOR HIGHWAY CONSTRUCTION**

DEPARTMENT OF TRANSPORTATION AND PUBLIC WORKS

---

**BEDDING MATERIAL**

**220**

---

220.01 Description

This work involves the supply of granular bedding material for trenches, catch basins, storm sewers, sidewalks, conduits or similar work.

220.02 Material

Bedding material shall be the material specified in the Tender document and it shall be in accordance with Section 401 or 402.

220.03 Construction Method

Bedding material shall be placed and compacted to 95% Standard Proctor Density except when under existing or proposed asphalt which shall be compacted to 100% Standard Proctor Density in accordance with Section 209.

220.04 Method of Measurement

Measurement for payment of bedding material shall be the number of tonnes or cubic metres placed.

220.05 Basis of Payment

Payment for bedding material shall be at the unit bid price per tonne or per cubic metre placed.

**GENERAL PROVISIONS AND CONTRACT SPECIFICATIONS  
FOR HIGHWAY CONSTRUCTION**

DEPARTMENT OF TRANSPORTATION AND PUBLIC WORKS

---

**DRAINAGE**

**300**

---

- 301 Storm Sewer Pipe Installation
- 302 Catch Basin Installation
- 303 Catch Basin, Manhole and Valve Adjustment
- 304 Drain Tile Installation
- 305 Roadway Culvert Installation
- 306 Driveway Culvert Placement
- 307 Culvert Extension
- 308 Culvert Removal
- 309 Timber Box Culvert
- 310 Concrete Box Culvert
- 311 Multi-Plated Corrugated Steel Arch
- 312 Culvert End Treatment

**GENERAL PROVISIONS AND CONTRACT SPECIFICATIONS  
FOR HIGHWAY CONSTRUCTION**

DEPARTMENT OF TRANSPORTATION AND PUBLIC WORKS

---

**STORM SEWER INSTALLATION**

**301**

---

301.01 Description

The work of this Section shall consist of storm sewer installation of Pre-cast Concrete Pipe (PCP), Corrugated Steel Pipe (CSP), or Poly Vinyl Chloride Pipe (PVC) excavation of trenches, placement of bedding material, dewatering, and backfilling.

301.02 Material

301.02.01 Pre-cast Concrete Pipe (PCP)

Unless specified otherwise in the Tender document, all concrete storm sewer pipes, outfall pipes, catch basin leads and flexible gaskets are to be supplied by the Contractor.

Concrete storm sewer pipe, outfall pipe, and catch basin lead are to be to ASTM C-76, Class III reinforced concrete pipe designed for flexible rubber gasket joints to ASTM C-443 and to the diameter indicated on the Drawings.

301.02.02 Corrugated Steel Pipe (CSP)

Unless specified otherwise, all corrugated steel storm sewer pipes, outfall pipes, catch basin leads and couplings are to be supplied by the Department in accordance with Provision 104.13.

301.02.03 Double Walled Polyethylene (DWP) or Poly Vinyl Chloride Pipe (PVC)

Unless specified in the Tender Agreement, all Double Walled Polyethylene or PVC Pipe, pipe fittings and gaskets are to be supplied by the Contractor.

Double Walled Polyethylene Pipe, 300 mm to 900 mm diameter, has a smooth-walled interior and a corrugated exterior wall that is manufactured in standard lengths of approximately six (6) metres to class R 320 (320 kPa) and is joined together with split ring couplers, integral snap bell connection or integral gasketed bell and spigot connection and which meets the requirements of CSA B182.6, or CSA B182.8.

For diameters up to 450 mm, a PVC pipe (SDR35) with integral gasketed bell and spigot joints can be used which meets the requirements of CSA B182.1, and CSA B182.2.

301.03 Construction Method - General

The Contractor shall begin work at the downstream end of the section to be installed. Trench excavation, bedding and backfill shall be in accordance with Section 217. The excavated width of the bottom of the trench shall not be less than 300 mm nor more than 600 mm greater than the diameter of the pipe. At the location of any bends, the trench shall be shaped to accommodate bends.

All excavated trenches shall conform to the Prince Edward Island Occupational Health and Safety Act and Regulations with particular note to Part 12 and Part 50.

Bedding material shall be placed by hand, in layers not exceeding 150 mm, under the bottom one third( $\frac{1}{3}$ ) of the pipe for PCP and CSP pipes. DWP and PVC pipes shall be backfilled with bedding material to 300 mm above pipe or pipe diameter whichever is less.



**GENERAL PROVISIONS AND CONTRACT SPECIFICATIONS  
FOR HIGHWAY CONSTRUCTION**

DEPARTMENT OF TRANSPORTATION AND PUBLIC WORKS

---

**STORM SEWER INSTALLATION**

**301**

Pipes are to be installed with the use of laser or survey equipment specifically manufactured for pipe installation. Pipes which are not true in alignment or which show improper installation shall be taken out and relaid at the Contractor's own expense.

Exposed inlets and outlets of the storm sewer system shall be tapered 3:1 (horizontal:vertical) and fitted with a grate that restricts access to the system. Grate bar spacing shall not exceed 140 mm. Bars should be oriented vertically at inlets and horizontally at outlets.

301.03.01 Pre-cast Concrete Pipe (PCP)

For PCP installation, recesses shall be excavated for the bells. The bell ends shall be placed up-grade with the spigot end fully entered into the bell.

301.03.02 Corrugated Steel Pipe (CSP)

CSP shall be installed in such a manner so that the inside circumferential laps point downstream. Corrugated steel pipe couplings shall be placed so that the joint of the couplings are near horizontal. The bolted joint connection on the coupling should be overlapped from the top, and should be located on the lower half of the culvert (i.e. between '3 and 9 o'clock').

301.03.03 Double Walled Polyethylene (DWP) and Poly Vinyl Chloride Pipe (PVC)

For Polyethylene and PVC installation, recesses shall be excavated for bells. The bell ends shall be placed up-grade with the spigot end fully entered into the bell.

301.04 Method of Measurement

Measurement for PCP, CSP, DWP or PVC under this Section shall be the number of linear metres of pipe installed for each diameter of pipe used in the work.

Bedding material supplied under this Section shall be measured for payment in accordance with Section 220.

Additional material supplied for backfill shall be measured in accordance with the respective specification.

301.05 Basis of Payment - General

Payment under this Section shall be at the unit bid price for each diameter of pipe installed and this price shall be full compensation for excavation, disposal of waste or surplus material, shoring, bracing, placement of bedding, placement of pipe, tapering exposed inlets and outlets, dewatering, backfilling, compaction, equipment, tools, lasers or survey equipment, labour, water for compaction and incidentals necessary to perform the work.

Payment for supply of bedding material and additional backfill material shall be made in accordance with the respective specification.

301.05.01 Pre-cast Concrete Pipe (PCP)

**GENERAL PROVISIONS AND CONTRACT SPECIFICATIONS  
FOR HIGHWAY CONSTRUCTION**

DEPARTMENT OF TRANSPORTATION AND PUBLIC WORKS

---

**STORM SEWER INSTALLATION**

**301**

The unit bid price for PCP installation, as defined in Provision 301.05, shall also be full compensation for the supply of the concrete pipe, outfall pipe, grates, catch basin leads and gaskets unless specified otherwise in the Tender document.

301.05.02     Corrugated Steel Pipe- (CSP)

The unit bid price for CSP installation as defined in Provision 301.05 shall not include compensation for the corrugated steel pipe, outfall pipe, catch basin leads or couplings; as these will be supplied by the Department in accordance with Provision 104.13 unless specified otherwise in the Tender document.

301.05.03     Double Walled Polyethylene (DWP) and Poly Vinyl Chloride Pipe (PVC)

The unit bid price for polyethylene and PVC pipe installation, as defined in Provision 301.05, shall be full compensation for the supply of the PVC pipe, grates, gaskets and incidentals required to install this product.

**GENERAL PROVISIONS AND CONTRACT SPECIFICATIONS  
FOR HIGHWAY CONSTRUCTION**

DEPARTMENT OF TRANSPORTATION AND PUBLIC WORKS

---

**CATCH BASIN INSTALLATION**

**302**

302.01 Description

The work of this Section shall consist of the installation of precast concrete (PCP - Pre-cast Concrete Pipe) or corrugated steel (CSP - Corrugated Steel Pipe) catch basins, grade rings, adjusting rings, frames and covers including excavation, placement of bedding material, dewatering, backfilling and compaction.

302.02 Material

302.02.01 Pre-cast Concrete (PCP) Catch Basin

Unless specified otherwise in the Tender document, all pre-cast catch basins, grade rings, adjusting rings, frames, and covers are to be supplied by the Contractor.

Precast catch basin sections for municipal services are to be to ASTM C-478, circular, with a flat top section and opening offset. Catch basins shall be constructed with a precast or cast-in-place base.

Adjusting rings shall be precast or cast-in-place as indicated on the Drawings or as directed by the Engineer and shall be the same shape as the frames and covers. The outer size of the adjusting rings must be at least as large as the frames and covers but shall not extend beyond the edge of the catch basin.

Joints are to be made watertight using bituminous gaskets or neoprene O-rings.

Frames and covers are to be standard, tough, grey cast iron to ASTM A-48 and are to be the type and manufactured as indicated on the Drawings. Bearing surface of covers are to be cast or machined to give continuous contact over the entire surface.

302.02.02 Corrugated Steel (CSP) Catch Basin

Unless specified otherwise in the Tender document, all corrugated steel catch basins, rings and covers are to be supplied by the Department in accordance with Provision 104.13. Adjusting rings shall be steel ring inserts made to the specific height required and made to fit inside the existing frame and to accept cover. The design of the steel ring insert shall be approved by the Engineer prior to the manufacturing.

302.03 Construction Method - General

The Contractor shall excavate to the invert elevation and undercut the elevation by 150 mm. The minimum dimension of a catch basin excavation shall be no less than 1 m larger than the diameter of the catch basin.

The granular bedding material shall be placed and compacted such that an area is created 300 mm larger than the diameter of the catch basin.

Backfilling and excavation shall be done in accordance with Section 217 and as specified herein.

The Contractor shall seal all connections between the catch basin and the base, inlets or outlets of storm drains prior to backfilling. When grouting is required to seal these connections, it shall be completed on both the inside and outside of the catch basin.

**GENERAL PROVISIONS AND CONTRACT SPECIFICATIONS  
FOR HIGHWAY CONSTRUCTION**

DEPARTMENT OF TRANSPORTATION AND PUBLIC WORKS

---

**CATCH BASIN INSTALLATION**

**302**

302.03.01 Pre-cast Concrete (PCP) Catch Basin

Pre-cast bases shall be placed on the bedding material and levelled. If the base is to be cast in place, the Contractor shall ensure a proper surface is formed to accept the intermediate sections.

The Contractor shall place a ring of mortar on the pre-cast or cured in-place base to the circumference of the catch basin. The first pre-cast catch basin section shall be placed in the mortar so that it is level and so that the joint is completely sealed. The subsequent pre-cast intermediate or top sections will be placed and sealed using rubber o-rings or ram-nek and properly orientated to ensure the specified inlets and outlets. Precast adjusting rings shall be placed on top of the catch basin structure using ram-nek or other approved sealant and shall be oriented properly to match the longitudinal and cross slopes required. Cast-in-place adjusting rings shall be formed and poured in place in a manner to provide a watertight seal. Ram-nek or other approved sealant shall be used to join the adjusting ring and frame.

302.03.02 Corrugated Steel (CSP) Catch Basin

The Contractor shall place 3 level concrete bricks or blocks 100 mm in height around the circumference of the corrugated steel catch basin. The top of the corrugated steel catch basin when placed shall be at the specified grade and shall be orientated to ensure proper inlet and outlet connections. Cast-in-place concrete shall be placed inside and outside the corrugated steel catch basin to a minimum thickness of 250mm and shall be given sufficient time to cure prior to backfilling. If height adjustment is required due to improper manufacturing or improper placement of catch basin, the contractor shall supply and place adjusting rings as required.

302.04 Method of Measurement

Measurement under this Section shall be the number of pre-cast concrete (PCP) or corrugated steel (CSP) catch basins installed for each diameter specified.

302.05 Basis of Payment - General

Payment under this Section shall be at the unit bid price for the number of catch basins installed for each diameter and this price shall be full compensation for installation, excavation, dewatering, undercutting, shoring, bracing, placement of bedding material, construction of forms, construction of bases, placement of backfill, compaction and equipment, cement, concrete, tools, labour, water for compaction and incidentals necessary to perform the work.

Payment for supply of bedding material and additional backfill material will be made in accordance with the respective specification.

**GENERAL PROVISIONS AND CONTRACT SPECIFICATIONS  
FOR HIGHWAY CONSTRUCTION**

DEPARTMENT OF TRANSPORTATION AND PUBLIC WORKS

---

**CATCH BASIN INSTALLATION**

**302**

302.05.01     Pre-cast Concrete (PCP) Catch Basin

The unit bid price for pre-cast concrete catch basin installation as defined in Provision 302.05 shall also be full compensation for the supply of the pre-cast concrete catch basins, adjusting rings, frames and covers unless specified otherwise in the Tender document.

302.05.02     Corrugated Steel (CSP) Catch Basin

The unit bid price for corrugated steel catch basins as defined in Provision 302.05 shall not include compensation for the corrugated steel catch basins, frames or covers; as these materials will be supplied by the Department unless otherwise specified in the Tender document. The unit bid price shall include full compensation for the supply and installation of adjusting rings if they are required due to improper installation by the Contractor.

**GENERAL PROVISIONS AND CONTRACT SPECIFICATIONS  
FOR HIGHWAY CONSTRUCTION**

DEPARTMENT OF TRANSPORTATION AND PUBLIC WORKS

---

**CATCH BASIN, MANHOLE AND VALVE ADJUSTMENT**

**303**

303.01 Description

This work shall consist of raising or lowering existing corrugated steel or concrete catch basins and concrete manholes or valve boxes to meet the final pavement elevation.

303.02 Material

The Contractor shall supply the appropriate type of material to perform the required work.

Adjusting rings for precast concrete structures shall be precast or cast-in-place as indicated on the Drawings or as directed by the Engineer and shall be the same shape as the frames and covers. The outer size of the adjusting rings must be at least as large as the frames and covers but shall not extend beyond the edge of the catch basin.

Adjusting rings for corrugated steel catch basins shall be steel ring inserts made to the height required specifically to fit inside the seat of the existing frame and also to accept the cover. The design of the steel ring insert shall be approved by the Engineer prior to manufacturing.

303.03 Construction Method

The Contractor, when raising existing corrugated steel catch basins, shall determine the height required to meet the new grade and shall manufacture a steel ring insert to raise the catch basin cover to the desired grade.

The Contractor when lowering existing corrugated steel catch basins shall cut and remove any existing pavement around the catch basin, excavate around the catch basin to a depth sufficient to adjust the catch basin to the desired elevation. The Contractor shall cut the catch basin vertically to remove the ring and cover and shall reset the ring and cover into the corrugation at the new pavement elevation. The Contractor shall insure that the ring and cover are secure and will not pop out under traffic.

The Contractor, when raising existing concrete catch basins or manholes, shall use concrete grade rings or shall supply cast-in-place concrete to the appropriate depth to meet the new grade. When lowering concrete catch basins or manholes, the Contractor will remove grade rings to meet the new grade.

The Contractor shall use the available adjustment of the valve boxes, or supply extension pieces or modify existing, to raise or lower the valve box to the appropriate elevation.

The Contractor shall ensure methods and materials are acceptable to the appropriate utility owners.

**GENERAL PROVISIONS AND CONTRACT SPECIFICATIONS  
FOR HIGHWAY CONSTRUCTION**

DEPARTMENT OF TRANSPORTATION AND PUBLIC WORKS

---

**CATCH BASIN, MANHOLE AND VALVE ADJUSTMENT**

**303**

303.04 Method of Measurement

The quantity to be measured under this Section shall be the number of catch basins, manholes or valve boxes actually raised or lowered.

Pavement placed while performing this work shall be measured for payment in accordance with Section 709.

303.05 Basis of Payment

Payment under this Section shall be at unit bid price per catch basin or manhole actually lowered or raised and this price shall be full compensation for all adjustment rings, equipment, tools, labour, and incidentals necessary to complete the work.

Payment of pavement restoration shall be made in accordance with Section 709.

**GENERAL PROVISIONS AND CONTRACT SPECIFICATIONS  
FOR HIGHWAY CONSTRUCTION**

DEPARTMENT OF TRANSPORTATION AND PUBLIC WORKS

---

**DRAIN TILE INSTALLATION**

**304**

---

304.01 Description

This specification applies to the supply and installation of drain tile in the shoulder region of the highway.

304.02 Material

The drain tile is to be 100 mm diameter, Type 2, perforated corrugated plastic tubing in compliance with CGSB 41-GP-29 Ma.

304.03 Drain Tile Location

The drain tile is to be placed in the shoulder of the highway along a line parallel to the outside edge of the pavement, or as outlined in the plans or drawings or as directed by the Engineer.

304.04 Drain Tile Depth and Grading

The drain tile shall be placed 1 m below the normal grade of the edge of the asphalt surface, or as outlined in the plans or drawings or as directed by the Engineer.

The constructed grade should not deviate from the design grade by more than 15% of the drain tile diameter. It is intended that the drain tile be located at a consistent depth in the cross-section. Reverse grades are not allowed.

304.05 Laying Drain Tile - Open Trench Installation

The method of installation is to be with trencher, Ditch Witch or equivalent, equipment. A backhoe with a 300 mm wide bucket may be used; however, extra costs for drainage aggregate shall be incidental.

The equipment shall construct a smooth bottomed open trench 300mm in depth. The width of the opening shall conform closely to the outside diameter of the drain tile.

The drain tile shall be placed in the bottom of the trench and the remainder of the trench shall be filled with Class D drainage aggregate. The drain tile must be protected from deformation during placement of the Class D aggregate.

Following placement of the Class D aggregate the trench shall be covered with the Granular Base prior to the road being opened to traffic to provide additional protection to the drain tile.

Drain tile shall not be stretched more than 7% of its normal length. Directional changes in drain tile can be made without the use of fittings, provided the centre-line radius of the bend is not less than 5 times the tube diameter.

This is the preferred method of drain tile installation.

304.06 Laying Drain Tile - Plow Installation

The method of installation is to be with drainage plow equipment. This is not the preferred method of installation and shall be approved only if the Contractor can demonstrate to the Engineer that the installation is acceptable



**GENERAL PROVISIONS AND CONTRACT SPECIFICATIONS  
FOR HIGHWAY CONSTRUCTION**

DEPARTMENT OF TRANSPORTATION AND PUBLIC WORKS

---

**DRAIN TILE INSTALLATION**

**304**

---

The drainage plow equipment should construct a smooth bottomed opening in the soil and maintain the opening until the flexible drain tile has been properly installed.

The size of the opening should conform closely to the outside diameter of the drain tile.

Drain tile must be protected from deformation and from floating in wet trenches.

The inside of the drain tile shall be kept clean during construction. All soil and debris shall be removed before additional tubing is laid.

Drain tile shall not be stretched more than 7% of its normal length. Directional changes in drain tile can be made without the use of fittings, provided the centre-line radius of the bend is not less than 5 times the tube diameter.

**304.07 Connections**

Where lengths of drain tile are to be joined, the ends must be square and all ragged or burred edges removed. A plastic coupling shall be used to secure the ends of the drain tile in proper alignment and to prevent the joint from separating during installation.

**304.08 Backfilling**

At the end of each day, the exposed end of the drain tile is to be covered to prevent entry of debris or sediment. During this process, care shall be taken to ensure that the drain tile is not damaged from excessive traffic or equipment loads.

**304.09 Filter Envelopes**

The drain tile is to be installed with an envelope material surrounding the drain tile to restrain the entry of base soil particles.

**304.10 Outfall**

Drains will be located at regular 400 m outfall intervals and will discharge into the roadside ditch subject to a minimum freeboard distance of 300 mm as shown on the contract Drawings. Where the 300 mm freeboard between the end pipe invert and the ditch bottom is not achievable, the Engineer will determine the location of the drain; in some cases, the drain may have to be relocated or omitted for this reason.

The outfall end pipe is to be 100 mm in diameter of rigid non-perforated pipe complete with a hinged grate. The joint between the end pipe and the drain tile shall be securely sealed.

**304.11 Method of Measurement**

The quantities to be measured for payment under this Section shall be the number of linear metres of drain tile installed and the number of outfalls installed.

No measurement for payment will be made under this Section for drain tile or outfall installations required as a result of faulty placement.

**GENERAL PROVISIONS AND CONTRACT SPECIFICATIONS  
FOR HIGHWAY CONSTRUCTION**

DEPARTMENT OF TRANSPORTATION AND PUBLIC WORKS

---

**DRAIN TILE INSTALLATION**

**304**

304.12 Basis of Payment

Payment under this Section shall be at the unit bid price per linear metre of drain tile and per outfall and this price shall be full compensation for all work, materials, labour, equipment and incidentals necessary to carry out the work.

Payment for the supply of drainage aggregate shall be accordance with Section 220. Excess drainage aggregate required to fill trench created by backhoe and bucket shall not be measured for payment.

**GENERAL PROVISIONS AND CONTRACT SPECIFICATIONS  
FOR HIGHWAY CONSTRUCTION**

DEPARTMENT OF TRANSPORTATION AND PUBLIC WORKS

---

**ROADWAY CULVERT INSTALLATION**

**305**

---

305.01 Description

The work to be carried out under this Section shall include the removal of existing roadway culverts, all excavation, and the installation of new roadway culverts.

305.02 Material

Unless otherwise specified in the Tender, Corrugated Steel Pipe (CSP) culverts and couplings shall be supplied and delivered by the Department, subject to the requirement of 24 hours notice by the Contractor.

Concrete pipe specified in the Tender to be used as roadway culvert are to be ASTM C-76 Class III reinforced concrete pipe designed for flexible rubber gasket joints to ASTM C-443.

Roadway culvert which is specified to be concrete pipe is to be supplied by the contractor and included in the Unit bid price for this work. Gaskets, elbows and other products associated with concrete pipe are to be included in the unit bid price.

305.03 Construction Method

Unless approved by the Engineer, the Contractor shall make provisions for two-way traffic during the work. All work carried out under this Section shall be done in accordance with the Environmental Requirements of Appendix 2.

Excavation shall begin at the downstream end of the pipe, and shall be performed in accordance with Section 203 and shall comply with the Occupational Health and Safety Act and Regulations.

Culverts carrying streamflow shall be installed under any restriction of the Stream Alteration Permit issued by the PEI Department of Environmental Resources. The pipe shall be laid parallel to flow on a uniform slope of 200:1 unless otherwise specified, and shall have the inlet and outlet positioned 150 mm to 300 mm below the bottom of the streambed.

The Contractor shall excavate the roadbed to the specified line and grade to a width of 600 mm on both sides of the pipe. The excavated material shall be conserved for re-use as directed by the Engineer, and it shall be stockpiled in a manner and location which will not endanger the work or delay the travelling public.

Existing roadway culverts shall be removed in accordance with Section 308.

Bedding material shall be placed to a depth of a 150 mm below the pipe and in layers not exceeding 150 mm under the bottom  $\frac{1}{3}$  of the pipe. Bedding material shall be compacted to 100% Standard Proctor Density in accordance with Section 209. In confined areas of the excavation, bedding shall be compacted using suitable hand or plate tampers. In the case of concrete pipe, the bed shall be shaped to ensure uniform load bearing around the bell end.

When corrugated steel pipe is to be used, it shall be installed in such a manner, that the inside circumferential laps point downstream. The coupling shall be placed as to bring the joint of the coupling near horizontal. In the case of a concrete pipe the bell ends are to be placed upgrade and the spigot ends are to be fully entered into the bells. All joints are to be as tight as possible.

**GENERAL PROVISIONS AND CONTRACT SPECIFICATIONS  
FOR HIGHWAY CONSTRUCTION**

DEPARTMENT OF TRANSPORTATION AND PUBLIC WORKS

---

**ROADWAY CULVERT INSTALLATION**

**305**

---

Helical corrugated steel pipe shall be placed so the helix angle is constant for the total length of the installation and each pipe section in a series shall be installed so the lock seam forms a continuous helix.

Prior to backfilling, the work shall be inspected. Backfilling shall be by hand under the bottom half of the pipe. Machine backfilling is acceptable for the remaining work provided compaction is achieved on individual layers not exceeding 200 mm. Backfill material shall be that approved by the Engineer. Stones larger than 100 mm shall not be placed within 300 mm of the pipe.

Compaction shall be achieved in accordance with Section 209 to 100% Standard Proctor Density.

Immediately upon completion of culvert installation or, as a minimum, at the end of the work day, disturbed slope areas within 10 m of the culvert shall be stabilized as indicated in Section 312 - Culvert End Treatment.

Where directed by the Engineer, old roadbed culverts shall be removed and relayed, extended or renewed in the same manner as specified for new culverts.

All pipe placed under this Section which is not in true alignment or which shows any settlement after laying shall be taken out and relayed at the Contractor's own expense.

**305.04 Method of Measurement**

The quantity to be measured for payment under this Section shall be the number of linear metres for all installed culverts less than, or equal to, 900 mm in diameter.

The measurement for payment for all installed culverts greater than 900 mm in diameter shall be per linear metre for each size.

New material supplied for backfilling roadway culverts shall not be measured for payment under this Section but shall be included elsewhere in the Contract.

No measurement for payment will be made under this section for culvert end treatments but shall be made under Section 312.

**305.05 Basis of Payment**

Payment under this Section shall be at the unit bid price per linear metre for any diameter of CSP culvert less than, or equal to, 900 mm used for the laying or relaying of roadway culverts and this price shall be full compensation for unloading, laying, backfilling, compacting, equipment, labour and incidentals necessary to perform the work.

Payment under this Section shall be at the unit bid price per linear metre for each size of CSP culvert larger than 900 mm in diameter for the laying or relaying of roadway culverts and this price shall be full compensation for the unloading, laying, backfilling, compacting, equipment, labour and incidentals necessary to perform the work.

Payment under this Section shall be at the unit bid price per linear metre for each size of concrete culvert (or other materials when supplied by the Contractor) for the laying or relaying of roadway culverts and this price shall be full compensation for the supply, unloading, laying,

**GENERAL PROVISIONS AND CONTRACT SPECIFICATIONS  
FOR HIGHWAY CONSTRUCTION**

DEPARTMENT OF TRANSPORTATION AND PUBLIC WORKS

---

**ROADWAY CULVERT INSTALLATION**

**305**

---

backfilling, compacting, equipment, labour and incidentals necessary to perform the work.

Payment for the supply of backfill material required under this Section shall be in accordance with the respective specification.

Payment for the supply of bedding material shall be in accordance with Section 220.

Payment for excavation shall be in accordance with Section 203 but the volume to be measured for pipe excavation shall not exceed the volume calculated by the product of the depth equal to the distance from the underside of bedding to the underside of common roadway excavation by the width equal to the nominal pipe diameter plus 1.2 metres. All other excavation required or directed by the Engineer to facilitate a smooth transition shall be paid at the price of common roadway excavation price.

Payment for removal of culverts shall be in accordance with Section 308.

Payment for culvert end treatments shall be in accordance with Section 312.

**GENERAL PROVISIONS AND CONTRACT SPECIFICATIONS  
FOR HIGHWAY CONSTRUCTION**

DEPARTMENT OF TRANSPORTATION AND PUBLIC WORKS

---

**DRIVEWAY CULVERT PLACEMENT**

**306**

---

306.01 Description

The work to be carried out under this Section shall include the installation and backfilling of driveway culverts.

306.02 Material

Unless otherwise specified in the Tender, all pipe and couplings shall be supplied by the Department in accordance with Provision 104.13.

306.03 Construction Method

The Contractor shall excavate the area to the lines and grades specified.

On the direction of the Engineer, the Contractor shall undercut the location of a driveway culvert to a specified depth. When no undercutting is specified, the Contractor shall grade the ditch uniformly and shall compact the ditch bottom to a depth of 300 mm, in accordance with Section 209 to 95% of Standard Proctor Density.

Corrugated metal pipe shall be placed with the inside circumferential laps pointing downstream. Couplings shall be so placed as to bring the joint of the coupling near horizontal. In the case of concrete pipe, the bed shall be shaped to ensure uniform load bearing around the bell ends which shall be placed upgrade and the spigot ends are to be fully entered into the bells. All joints are to be as tight as possible.

Polyethylene pipe installation is to follow the same installation procedure as outlined for Corrugated Metal Pipe.

Backfill material shall be approved by the Engineer and shall be placed by hand under the bottom half of the culvert. The top half of the culvert may be backfilled by machine in layers not exceeding 200 mm.

The top of the driveway shall be constructed to a width of not more than 6.1 m unless otherwise directed by the Engineer. The backfill material at each end of the culvert shall be neatly graded and shaped to provide a uniform slope not steeper than 3:1 (horiz:vert).

Immediately upon completion of culvert installation or, as a minimum, at the end of the work day, disturbed slope areas within 10m of the culvert shall be stabilized as indicated in Section 312 - Culvert End Treatment.

Where directed by the Engineer, old driveway culverts shall be removed and relayed, extended or renewed in the same manner as specified for new culverts.

All pipe which is not in true alignment or which shows any settlement after laying, shall be taken out and replaced.

**GENERAL PROVISIONS AND CONTRACT SPECIFICATIONS  
FOR HIGHWAY CONSTRUCTION**

DEPARTMENT OF TRANSPORTATION AND PUBLIC WORKS

---

**DRIVEWAY CULVERT PLACEMENT**

**306**

306.04 Method of Measurement

The quantity to be measured under this Section shall be the number of linear metres of all installed culverts less than, or equal to, 900 mm in diameter.

No measurement for payment will be made under this section for culvert end treatments but shall be made under Section 312.

306.05 Basis of Payment

Placement of driveway culverts shall be paid for at the unit bid price per linear metre for all installed culverts less than, or equal to, 900 mm in diameter and this price shall be full compensation for all work, excavation, placing backfill, tools, equipment, labour and incidentals necessary to complete the work.

Payment for supply of pipe shall be included in unit bid price per size when materials are supplied by the Contractor.

Payment for the supply of bedding material shall be made in accordance with Section 220.

Payment for fill material shall be in accordance with the section for the type of material supplied.

Payment for culvert end treatments shall be in accordance with Section 312.

**GENERAL PROVISIONS AND CONTRACT SPECIFICATIONS  
FOR HIGHWAY CONSTRUCTION**

DEPARTMENT OF TRANSPORTATION AND PUBLIC WORKS

---

**CULVERT EXTENSION**

**307**

---

307.01 Description

The work to be carried out under this Section relates to the restoration of, or extension of, drainage culverts. This work is intended to be a maintenance measure where it is more economical to extend service life of an existing culvert than to replace it.

307.02 Material

All couplings and corrugated steel pipe or polyethylene pipe used to make the restoration shall be supplied by the Department in accordance with Provision 104.13.

All new concrete pipe to ASTM C-76 Class III reinforced concrete pipe designed for flexible rubber gasket joints to ASTM C-443 shall be supplied by the Contractor.

307.03 Construction Method

The Contractor shall excavate the existing fill material from around the end of the culvert and reserve it for re-use. Damage to the ends of the culvert, if present, shall be cut-off with a method approved by the Engineer. The result shall be a smooth, distortion-free, straight edge perpendicular to the line and grade of flow (i.e. gradient).

The Contractor shall excavate existing fill material from around the end of the concrete culvert to expose a full intact bell or spigot joint. The joint shall be completely cleaned prior to placing lubricant and gaskets and additional concrete pipe materials.

A length of corrugated steel pipe will be joined using a coupling band and the total exposed pipe shall be backfilled and shaped as necessary to restore the original drainage course. This may result in a culvert slightly longer or shorter than the original.

The culvert to be joined onto must be cleaned of soil and debris to ensure the culvert functions properly and to enable an effective coupling with the extension pipe.

The extension pipe shall be placed on a similar line and grade as the original pipe unless otherwise specified by the Engineer. The Contractor will ensure that this alignment is maintained throughout the work.

Couplings shall be placed so that the joint of the coupling is near horizontal. The joint should occur at mid-length of the coupling. The bolted joint connection on the coupling should be overlapped from the top, and should be located on the lower half of the culvert (i.e. between "3 and 9 o'clock").

Backfilling by hand is necessary below the mid-elevation of the culvert circumference, but may be done by machine for the upper regions.

All backfill material shall be approved by the Engineer and shall be compacted to 95% Standard Proctor Density except when under existing or proposed asphalt which shall be compacted to 100% Standard Proctor Density. Stones larger than 100 mm shall not be placed within 300 mm of the culvert.



**GENERAL PROVISIONS AND CONTRACT SPECIFICATIONS  
FOR HIGHWAY CONSTRUCTION**

DEPARTMENT OF TRANSPORTATION AND PUBLIC WORKS

---

**CULVERT EXTENSION**

**307**

---

Immediately upon completion of the culvert extension or, as a minimum, at the end of the work day, disturbed slope areas within 10m of the culvert shall be stabilized as indicated in Section 312 - Culvert End Treatment.

307.04 Method of Measurement

The quantity to be measured under this Section shall be the number of linear metres of culvert extension placed.

No measurement for payment will be made under this section for culvert end treatments but shall be made under Section 312.

307.05 Basis of Payment

Payment under this Section shall be at the unit bid price per linear metre and this price shall be full compensation for loading, material transportation, excavation, removal of damaged pipe sections, if any, coupling of culverts, supply or reinstatement of backfill material, compaction of backfill, shaping of backfill, and all equipment and labour necessary to complete the work.

Payment for supply of pipe shall be included in unit bid price per size when materials are supplied by the Contractor.

Extra backfill, if required, may be supplied at no additional cost from ditching or from surplus earth excavation generated within the work site. If the Engineer chooses to use a foundation material such as borrow it shall be paid for in accordance with the respective specification.

Payment for culvert end treatments shall be in accordance with Section 312.

**GENERAL PROVISIONS AND CONTRACT SPECIFICATIONS  
FOR HIGHWAY CONSTRUCTION**

DEPARTMENT OF TRANSPORTATION AND PUBLIC WORKS

---

**CULVERT REMOVAL**

**308**

308.01 Description

This work shall consist of the removal of roadway culverts and driveway culverts.

308.02 Construction Method

When the Engineer directs that roadway culverts or driveway culverts are to be removed from the roadway, the Contractor shall excavate the surrounding material and remove the culvert without damage.

The interior of the pipe shall be cleared of any accumulated sediment, rocks or debris.

Re-usable culverts shall be stockpiled for pickup by the Department. Culverts which in the opinion of the Engineer are not worthy of salvage shall be disposed of by the Contractor.

The Engineer shall establish the limits of material to be removed in order to recover any culvert and the Contractor shall not excavate beyond the limits established by the Engineer.

308.03 Method of Measurement

Measurement for payment under this Section shall be the number of linear metres of culvert salvaged or disposed of.

No measurement for payment will be made for excavation of materials required for the removal of driveway culverts.

Measurement for payment will be made for excavation of materials required for the removal of roadway culverts.

308.04 Basis of Payment

Removal of culverts shall be paid for at the unit bid price per linear metre and this price shall be full compensation for removal, cleaning and stockpiling of the reusable culverts, disposal of un-salvageable culverts, equipment, tools, labour and incidentals necessary to complete the work.

Payment for excavation of materials required for removal of roadway culverts shall be in accordance with Section 203.

Suitable excavated materials will be reinstated at no additional cost as per Section 207.

Additional backfill materials will be paid under the respective section.

**GENERAL PROVISIONS AND CONTRACT SPECIFICATIONS  
FOR HIGHWAY CONSTRUCTION**

DEPARTMENT OF TRANSPORTATION AND PUBLIC WORKS

---

**TIMBER BOX CULVERT**

**309**

---

309.01 Description

This work consists of the building of a timber box culvert as shown in Figure 309-1 with pressure treated wood as shown on the Plans or as designated by the Engineer.

309.02 Material

The material shall be eastern hemlock graded to NLGA Rule 1 structural grade lumber (up to 25% may be Rule 2 structural) treated in accordance to CAN/CSA-080.1 M and with minimum preservative retention as per CAN/CSA 080.14.

Where non-treated lumber is specified as part of the construction it shall be hemlock and shall be approved by the Engineer before being used in the structure.

Hardware including pins, bolts, washers, nails and all other items necessary to be incorporated into the work shall be as shown on Figure 309-1 or as specified by the Engineer.

Borrow, bedding material, rip rap and other materials required for backfilling and bedding for the structure shall meet the respective specifications for that item.

309.03 Construction Method

The Contractor shall place signs and other warning devices and keep such in place and in good repair until the work is completed. Such warning devices shall meet the requirement of the respective specifications for that item. All work carried out under this Section shall be done in accordance with the Environmental Requirements of Appendix 2.

All asphalt pavement in the work area shall be cut and removed by the Contractor before the excavation is started. Existing culverts shall be removed and disposed of as part of this work.

The excavation shall be to an elevation as established by the Engineer to provide a hard bottom suitable to support the box structure.

Excavation to a depth of 1 m below the bottom of the sills shall be included in the bid price for the construction of the box. Excavation beyond the 1 m depth below the bottom of the sills shall be paid for as foundation excavation and shall be included in the unit bid price for this Section. In calculating this excavation quantity use the depth of the excavation below the 1 m, times the length of the box plus 2 m, times the width of the box plus 1 m on each side of the box.

Both during the excavation if required and after the excavation, all exposed soil on the slopes of the excavation shall be covered with a suitable material to prevent the potential of soil erosion and deposition into the stream.

The Contractor shall dismantle the existing structure and pile the used material in such a manner to facilitate its removal from the site. This material will be picked up by the Department and returned to the bridge stock yard or disposed of as directed by the Engineer.

The excavated hole shall be kept free of water during the placement of bedding material, sills and abutments for the new structure. This cost shall be included in the bid price.

**GENERAL PROVISIONS AND CONTRACT SPECIFICATIONS  
FOR HIGHWAY CONSTRUCTION**

DEPARTMENT OF TRANSPORTATION AND PUBLIC WORKS

---

**TIMBER BOX CULVERT**

**309**

---

The Contractor shall supply all labour and material necessary for the proper execution of the work as well as all necessary false work that may be required for the safety of the workmen.

The bedding material shall be compacted to 95% Standard Proctor Density except when under existing or proposed asphalt which shall be compacted to 100% Standard Proctor Density in accordance with Section 209. The surface of the bedding material shall have a uniform compacted surface. In confined areas of the excavation the bedding shall be compacted using suitable vibratory hand or plate tamper.

The treated wood culvert shall be laid out and the timber shall be placed and fastened as shown on the construction Drawings and as directed by the Engineer.

The sills on which the box is constructed must be located accurately to line, grade and span in accordance with the construction Drawings.

Assembly is performed on site directly on the prepared sills. Holes for drift pins shall be 3 mm less than the diameter of the pin and drilled to a depth of 50 mm less than the length of the pin. The heads of all pins shall be driven sufficiently into the timber that the overlaying timber will have a proper bearing on the timber beneath. Holes for the bolts shall be bored to the proper size so that the bolt can be driven without damage to the lumber. All bolts shall have 2 washers - 1 under the head and 1 under the nut.

Backfill to the top of the structure with select borrow in accordance with Sub-Provision 206.02.02. It shall be placed in layers of not more than 200 mm and compacted to a minimum of 100% of Standard Proctor Density. It shall be placed on both sides of the structure to approximately the same elevation simultaneously. From the top of the structure to the subgrade elevation the original excavated material shall be placed in layers and compacted to 100% Standard Proctor Density. If the excavated material is deemed to be unsuitable for backfill material (i.e. moisture content too high) then additional material as approved by the Engineer will be used in its place. The unsuitable material will be disposed of as per the Engineer's approval.

Random rip rap, R-25, in accordance with Section 213, shall be supplied and placed by the Contractor as directed by the Engineer. This shall include all work necessary to prepare the area to be ripped.

Unless approval is granted by the Engineer to establish a detour which would have to be signed according to Department specifications, two-way traffic must be maintained at all times.

**309.04 Method of Measurement**

Measurement for payment under this Section shall be by the FBM (Foot Board Measure) for all wood work.

Measurement for payment for excavation shall be in accordance with Section 203 and Provision 309.03.

Measurement for borrow, bedding material and rip rap shall be made in accordance with the respective specification.

**GENERAL PROVISIONS AND CONTRACT SPECIFICATIONS  
FOR HIGHWAY CONSTRUCTION**

DEPARTMENT OF TRANSPORTATION AND PUBLIC WORKS

---

**TIMBER BOX CULVERT**

**309**

---

309.05 Basis of Payment

Payment under this Section shall be at the unit bid price measured in FBM and this price shall be full compensation for all tools, equipment, labour, materials and other incidentals necessary to perform the work.

Payment for excavation except for the 1 m below the bottom of the sills under this Section shall be made in accordance with Section 203. Payment for the 1 m of excavation below the bottom of the sills shall be based on cubic metres as measured in accordance with Provision 309.03.

Payment for bedding material shall be made in accordance with Section 220.

Payment for borrow under this Section shall be made in accordance with Section 206.

GENERAL PROVISIONS AND CONTRACT SPECIFICATIONS  
 FOR HIGHWAY CONSTRUCTION  
 DEPARTMENT OF TRANSPORTATION AND PUBLIC WORKS

TIMBER BOX CULVERT

309

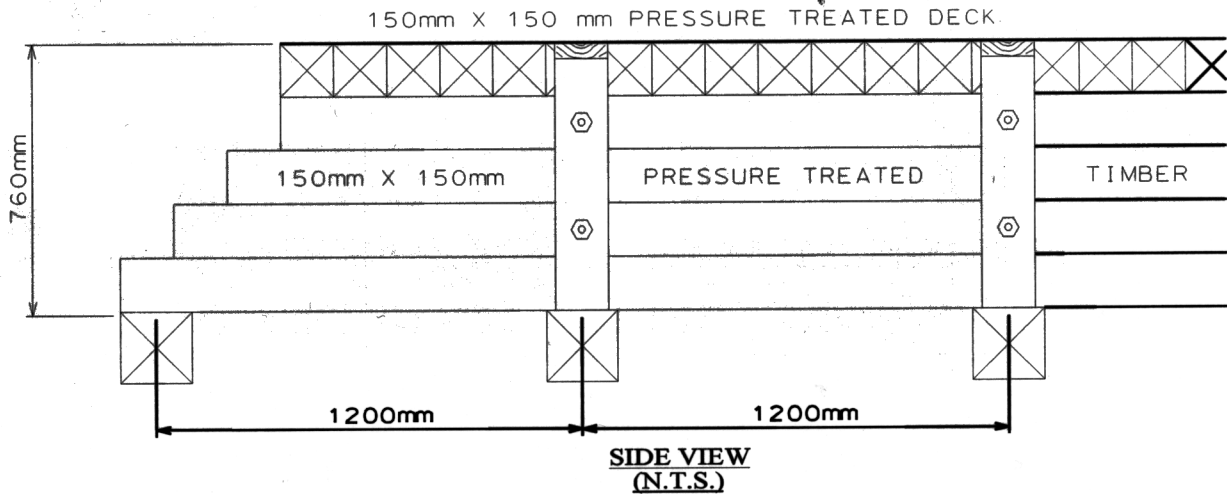
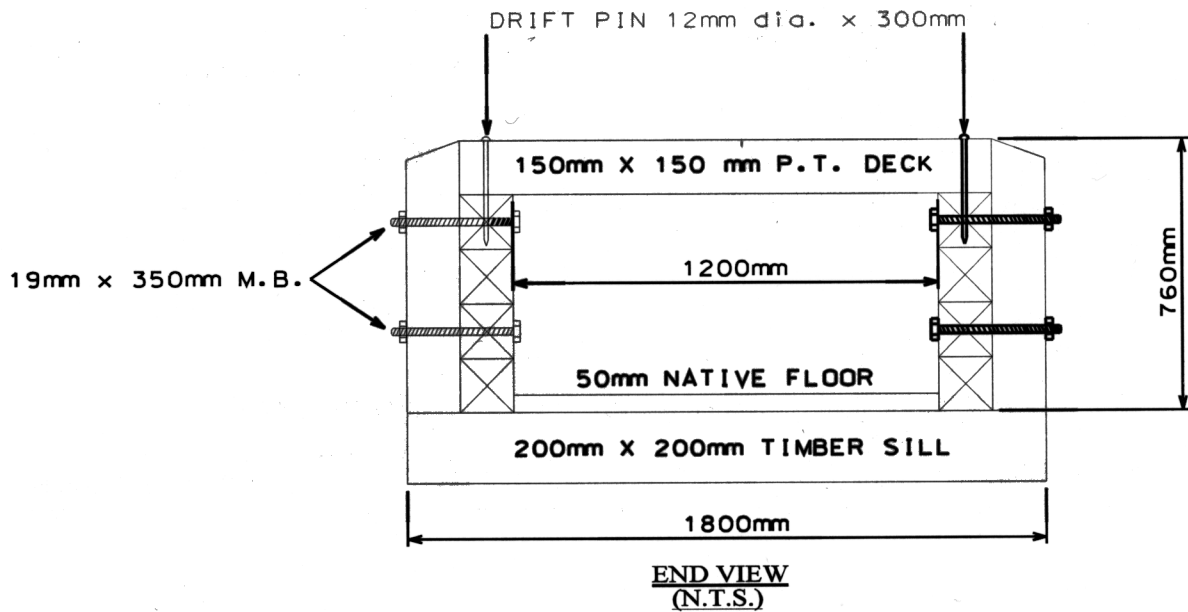

- NOTES: 1. Sills submerged in water to be native hemlock.  
 2. Sills on dry boxes to be pressure treated timber.  
 3. Slopes on culvert end to match foreslope.  
 4. Slope on driveway culvert ends to be a minimum 3H:1V

**FIGURE 309-01 PRESSURE TREATED TIMBER BOX CULVERT**

REVISED 2006

**GENERAL PROVISIONS AND CONTRACT SPECIFICATIONS  
FOR HIGHWAY CONSTRUCTION**

DEPARTMENT OF TRANSPORTATION AND PUBLIC WORKS

---

**CONCRETE BOX CULVERT**

**310**

---

310.01 Description

Work under this Section will require the removal of an existing structure and replacement with a concrete box culvert manufactured in accordance with ASTM C-789.

310.02 Material

Bedding material shall be as specified in accordance with Sections 401 and 402.

Backfill material shall be select borrow in accordance with Sub-Provision 206.02.02.

Concrete box culvert is a product manufactured in accordance with ASTM C-789 to the size and dimensions as shown on the Plan.

310.03 Construction Method

The Contractor shall organize the work such that the removal and replacement of any length of section is completed in the same day. The Contractor shall be required to set up adequate traffic control measures to the satisfaction of the Engineer prior to construction. The existing guiderail shall be dismantled and reinstalled by the Contractor. All work carried out under this Section shall be done in accordance with the Environmental Requirements of Appendix 2.

The asphalt shall be cut in a clean and vertical fashion. The asphalt shall be deemed as waste. Excavated material shall be piled such that it does not produce a traffic hazard. Surplus excavated material shall be deemed as waste material. The Contractor shall dewater the excavation in order to install the new box culvert and place the bedding material.

The bedding material shall be compacted to 95% Standard Proctor Density except when under existing or proposed asphalt which shall be compacted to 100% Standard Proctor Density in accordance with Section 209 prior to the placement of the concrete box culvert. The surface of the bedding material shall have a uniform compacted surface. In confined areas of the excavation the bedding shall be compacted using suitable vibratory hand or plate tampers.

The box culvert shall be placed to the lines and grades shown on the Plan and shall have all joints oriented downstream.

Backfilling of the structure using select borrow shall be done in symmetrical lifts with each lift no greater than 200 mm. Each lift placed shall be uniformly compacted to 100% Standard Proctor Density prior to the placement of any successive lift.

310.04 Method of Measurement

Measurement for payment under this Section shall be the number of concrete box culverts installed.

Excavation shall be measured by the average end area method in accordance with Section 203.

Bedding material shall be measured by the tonne placed in accordance with Section 220.

310.05 Basis of Payment

**GENERAL PROVISIONS AND CONTRACT SPECIFICATIONS  
FOR HIGHWAY CONSTRUCTION**

DEPARTMENT OF TRANSPORTATION AND PUBLIC WORKS

---

**CONCRETE BOX CULVERT**

**310**

Payment under this Section shall be at the unit bid price per concrete box culvert and this price shall be full compensation for supply and placement of the box culvert, bedding preparation, removal of existing culvert, dewatering, placing and compacting select borrow and incidentals necessary to complete the work.

Bedding material shall be paid for in accordance with Section 220.

Excavation shall be paid for in accordance with Section 203.



**GENERAL PROVISIONS AND CONTRACT SPECIFICATIONS  
FOR HIGHWAY CONSTRUCTION**

DEPARTMENT OF TRANSPORTATION AND PUBLIC WORKS

---

**MULTI-PLATED CORRUGATED STEEL ARCH**

**311**

---

311.01 Description

This work consists of the construction of a multi-plated corrugated steel arch.

311.02 Material

The plates shall be corrugated steel to CSA CAN 3-G A01-M15. All bolts and nuts shall be special heated steel to ASTM F-568 and ASTM A-563. The galvanizing on these bolts and nuts must meet CSA G-164 Class 5. Hardware including pins, bolts, washers, spikes and other necessary items for construction shall be as shown on Figure 311-1.

The arch rails shall be pressure treated eastern hemlock wood graded to NLGG Rule 1. At least 25% must be structural grade lumber treated in accordance with CAN/CSA 080.1 M and with a minimum preservative retention in accordance with 080.14 M.

Where non-treated lumber is specified it shall be approved by the Engineer.

Select borrow, bedding material, rip rap and other materials required for backfilling and bedding shall meet the respective specification.

311.03 Construction Method

The Contractor shall place and keep in good repair signs and other warning devices. Such warning devices shall meet the requirement of the respective specification. All work carried out under this Section shall be done in accordance with the Environmental Requirements of Appendix 2.

All asphalt pavement shall be cut and removed by the Contractor before excavation commences. Existing culverts shall be removed and disposed of as part of this work.

The excavation shall be to hard bottom suitable to support the arch to an elevation as established by the Engineer.

Excavation to a depth of 1 m below the bottom of the sills shall be included in the unit bid price for this Section. Excavation beyond 1 m below the sills shall be paid for as foundation excavation. In calculating this excavation use the depth of the excavation below the 1 m, times the length of the arch plus 2 m, times the width of the arch plus 1 m on each side of the arch.

Both during and after the excavation all exposed soil on the slopes of the excavation shall be covered with a suitable material to prevent soil erosion and deposition into the stream.

The Contractor shall dismantle the existing structure and pile the used material to facilitate its removal from the site. This material will be picked up by the Department and returned to the bridge stock yard or disposed of as directed by the Engineer.

The excavated hole shall be kept free of water during the placement of bedding material, sills and rails. This cost shall be included in the unit bid price.

The Contractor shall supply all labour and material necessary for the proper execution of the work; as well as, all necessary falsework that may be required for the safety of the workmen.

**GENERAL PROVISIONS AND CONTRACT SPECIFICATIONS  
FOR HIGHWAY CONSTRUCTION**

DEPARTMENT OF TRANSPORTATION AND PUBLIC WORKS

---

**MULTI-PLATED CORRUGATED STEEL ARCH**

**311**

---

Bedding material shall be compacted to 100% Standard Proctor Density in accordance with Section 209. The surface of the bedding material shall have a uniform compacted surface. In confined areas of the excavation the bedding shall be compacted using suitable vibratory hand or plate tampers.

The arch rails on which the bottom plates rest must be located accurately to line, grade and span in accordance with the construction Drawings.

Plate by plate assembly shall be performed directly on the arch rails. Holes for drift pins shall be 3 mm less than the diameter of the pin and drilled to a depth of 50 mm less than the length of the pin. The pin heads shall be driven so that the overlaying timber will have proper bearing on the timber beneath. The bolts should be torqued to a minimum of 250 N-m and a maximum of 500 N-m. The curved surface of the nut shall be placed against the plate.

Backfill to the top of the arch structure with select borrow in accordance with Sub-Provision 206.02.02. From the top of the structure, to the existing subgrade elevation, the original excavated material shall be placed. If the excavated material is deemed to be an unsuitable backfill material (i.e. moisture content too high) then additional material as approved by the Engineer will be used. The unsuitable material will be disposed of as per the Engineer's approval.

Backfill material shall be placed in layers no more than 200 mm and compacted to 100% of Standard Proctor Density in accordance with Section 209. Backfill material shall be placed on both sides of the structure simultaneously to approximately the same elevation.

R-25 random rip rap in accordance with Section 213, shall be supplied and placed by the Contractor as directed by the Engineer. This work shall include preparation of the area to be rip rapped.

Two-way traffic must be maintained at all times, unless the Engineer approves a detour.

**311.04 Method of Measurement**

Measurement for payment under this Section shall be by the FBM (Foot Board Measure) for all wood work and by the linear meter for the multi-plated steel arch.

Measurement for borrow shall be in accordance with Section 206.

Measurement for bedding material shall be in accordance with Section 220.

**311.05 Basis of Payment**

Payment under this Section shall be at the unit bid price per FBM for wood work and per linear metre for steel work and this price shall be full compensation for all work, tools, equipment, labour and incidentals necessary to perform the work.

Payment for excavation except for the 1 m below the bottom of the sills shall be made in accordance with Section 203. Payment for the 1 m of excavation below the bottom of the sills shall be based on cubic meters as measured in accordance with Provision 311.03.

Payment for borrow under this Section shall be made in accordance with Section 206.

Payment for bedding material shall be made in accordance with Section 220.

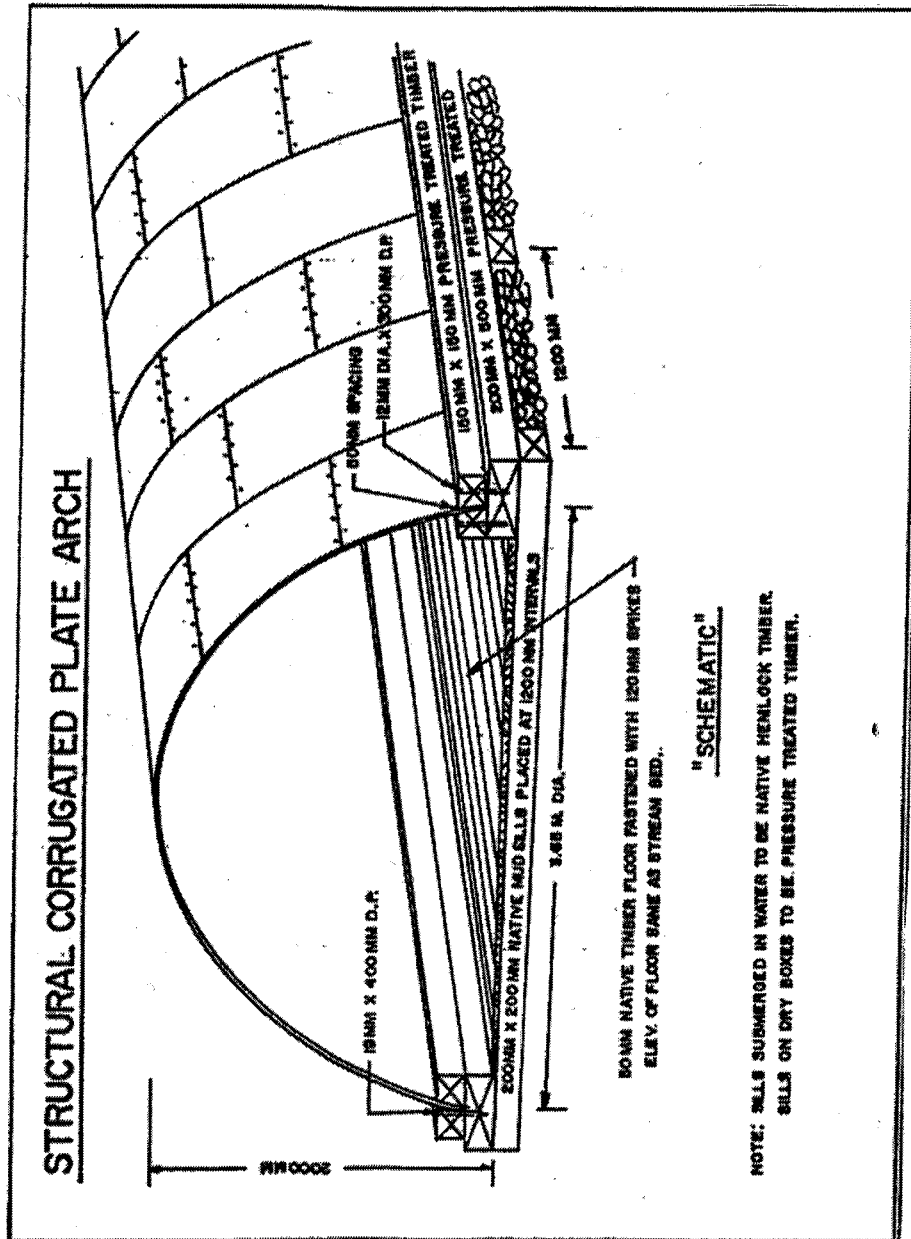

Figure 311-1 Multi-Plated Corrugated Steel Arch

**GENERAL PROVISIONS AND CONTRACT SPECIFICATIONS  
FOR HIGHWAY CONSTRUCTION**

DEPARTMENT OF TRANSPORTATION AND PUBLIC WORKS

---

**CULVERT END TREATMENT**

**312**

312.01 Description

The work to be carried out under this Section shall include the stabilization and protection of ditch slopes adjacent drainage culverts as a result of work carried out in Sections 215 - Ditching, 216 - Culvert End Cleanout, 305 - Roadway Culvert Installation, 306 - Driveway Culvert Placement, and 307 - Culvert Extension and shall include the necessary excavation and installation of geotechnical fabric, mulching and random rip rap as required to complete the work of this section.

312.02 Material

R-5 Rip Rap as specified in Section 213 Random Rip Rap.

Type N2 geotechnical fabric as specified in Section 218 - Geotechnical Fabric.

Mulching as specified in Section 805 - Mulching.

Erosion control mats as specified in Section 807 - Erosion Control Mats.

312.03 Construction Method - Roadway Culverts/High Erosion Potential Driveway Culverts

Immediately upon completion of roadway culvert installation or, as a minimum, at the end of the work day, disturbed slope areas within 10 m of the culvert shall be stabilized with mulch from top of foreslope to top of backslope.

At the inlet, the contractor shall place random R5 riprap to a 300mm depth over geotechnical fabric from the toe of the foreslope of the ditch to a minimum of 1 metre above the top of the culvert as indicated in Figure 312-01, Culvert End Treatment (Inlet). The riprap apron shall extend 2 meters on either side of the centreline of the culvert. The elevation of the ditch at the inlet shall not be lower than the culvert inlet. Mulch stabilization is acceptable at the culvert on a temporary basis not to exceed two days unless otherwise directed by the Engineer.

At the outlet, the contractor shall place random R5 riprap to a 300mm depth over geotechnical fabric from a minimum of 1 meter beyond the end of the culvert (into the ditch) to a minimum of 1 meter above the top of the culvert as indicated in Figure 312-02, Culvert End Treatment (Outlet). The riprap apron shall extend 2 meters on either side of the centreline of the culvert. For culverts not carrying streamflow, the elevation of the ditch at the outlet shall not be higher than the culvert outlet. Mulch stabilization is acceptable at the culvert on a temporary basis not to exceed two days otherwise directed by the Engineer.

At the inlet and outlet of the culvert to a minimum distance of 10 m on either side of the culvert, the remaining disturbed fill slope areas (not riprapped) shall be mulched from top of foreslope to top of backslope. This includes the slope area above the riprap to the top of the slope.

All mulch shall be removed from slopes prior to final grading. After slopes have been graded to the satisfaction of the Engineer, and the disturbed areas have been hydro seeded, then all areas shall be re-mulched or erosion control mats shall be placed as directed by Engineer.

**GENERAL PROVISIONS AND CONTRACT SPECIFICATIONS  
FOR HIGHWAY CONSTRUCTION**

DEPARTMENT OF TRANSPORTATION AND PUBLIC WORKS

---

**CULVERT END TREATMENT**

**312**

**312.04 Construction Method - Driveway Culverts - Low Erosion Potential**

Immediately upon completion of driveway culvert installation or, as a minimum, at the end of the work day, disturbed slope areas within 10m of the culvert shall be stabilized from top of foreslope to top of backslope.

At locations with low erosion potential (i.e. locations with small ditch flow volumes, low velocities, etc.), erosion control mat (i.e. jute mat, erosion control blanket) shall be installed from a minimum of 1 m beyond the end of the culvert (into the ditch) to a minimum of 1 m above the top of the culvert. At inlets to culverts the elevation of the ditch shall not be lower than the culvert inlet. At culvert outlets the elevation of the ditch shall not be higher than the culvert outlet. The erosion control mat shall extend 2 m on either side of the centerline of the culvert along the foreslope of the driveway or to a combined distance of 2m along the foreslope of the driveway and the foreslope and/or backslope of the roadway ditch. Remaining disturbed fill slope areas at the driveway shall be mulched. All mulch shall be removed from slopes prior to final grading. After slopes have been graded to the satisfaction of the Engineer, and the disturbed areas have been hydro seeded, then all areas shall be re-mulched or erosion control mats shall be placed as directed by Engineer.

**312.05 Construction Method - Ditching, Culvert End Cleanouts and Culvert Extension**

\_\_\_\_\_ The method of culvert end treatment stabilization and protection to be followed when carry out work relating to Sections 215 - Ditching, 216 - Culvert End Cleanout, and Section 307 - Culvert Extension shall be determined by the type of culvert being cleaned or extended. For example, if a roadway culvert is being extended then the Contractor shall follow the method described in provision 312.03 but if ditching is being carried out near a driveway culvert and the Engineer indicates that there is low erosion potential then the method to be followed shall be the method described in Provision 312.04.

**312.06 Method of Measurement**

Measurement for payment made under this section shall be the number of Roadway and High Erosion Potential Driveway culvert ends treated regardless of culvert diameter.

No measurement for payment will be made for excavation required to prepare the area for placement of the geotechnical fabric and rip rap as it will be considered incidental to the work of this Section.

No measurement for payment will be made for rip rap required under this section as it will be considered incidental to the work of this section.

No measurement for payment will be made for geotechnical fabric under this section as it will be considered incidental to the work of this section.

No measurement for payment will be made for Low Erosion Potential Driveway Culvert ends treated.

Measurement for payment for mulching and/or re-mulching shall be measured under Section 805 - Mulching.

**GENERAL PROVISIONS AND CONTRACT SPECIFICATIONS  
FOR HIGHWAY CONSTRUCTION**

DEPARTMENT OF TRANSPORTATION AND PUBLIC WORKS

---

**CULVERT END TREATMENT**

**312**

Measurement for payment for erosion control mats shall be measured under Section 807 - Erosion Control Mats.

312.07 Basis of Payment

Payment under this section shall be at the unit bid price for the number of Roadway and High Erosion Potential Driveway culvert ends treated regardless of culvert diameter and this price shall be full compensation for all excavation, rip-rap, geotechnical fabric, equipment, tools, labour, materials and incidentals necessary to complete the work of this section.

Payment for supply and placement of mulching and/or re-mulching required under this section shall be in accordance with Section 805 - Mulching.

Payment for supply and placement of erosion control mats required under this section shall be in accordance with Section 807 - Erosion Control Mats.

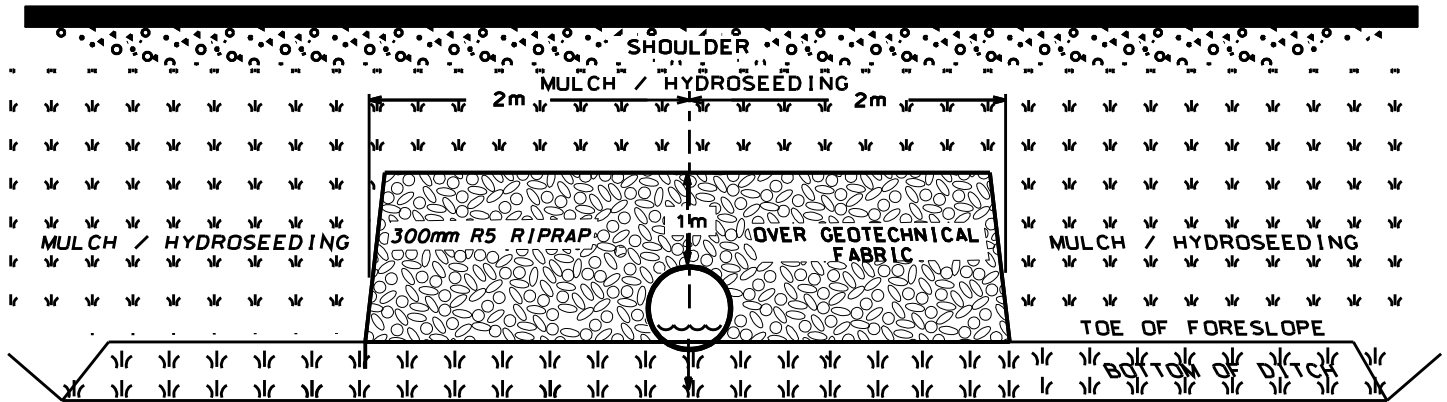

Note: An additional 7m to the left and right of the riprap, as well as above it to the shoulder, shall be mulched. Once fill slope areas are brought to final grade, and the areas are hydroseeded, the areas shall then be remulched.

END VIEW (N.T.S.)

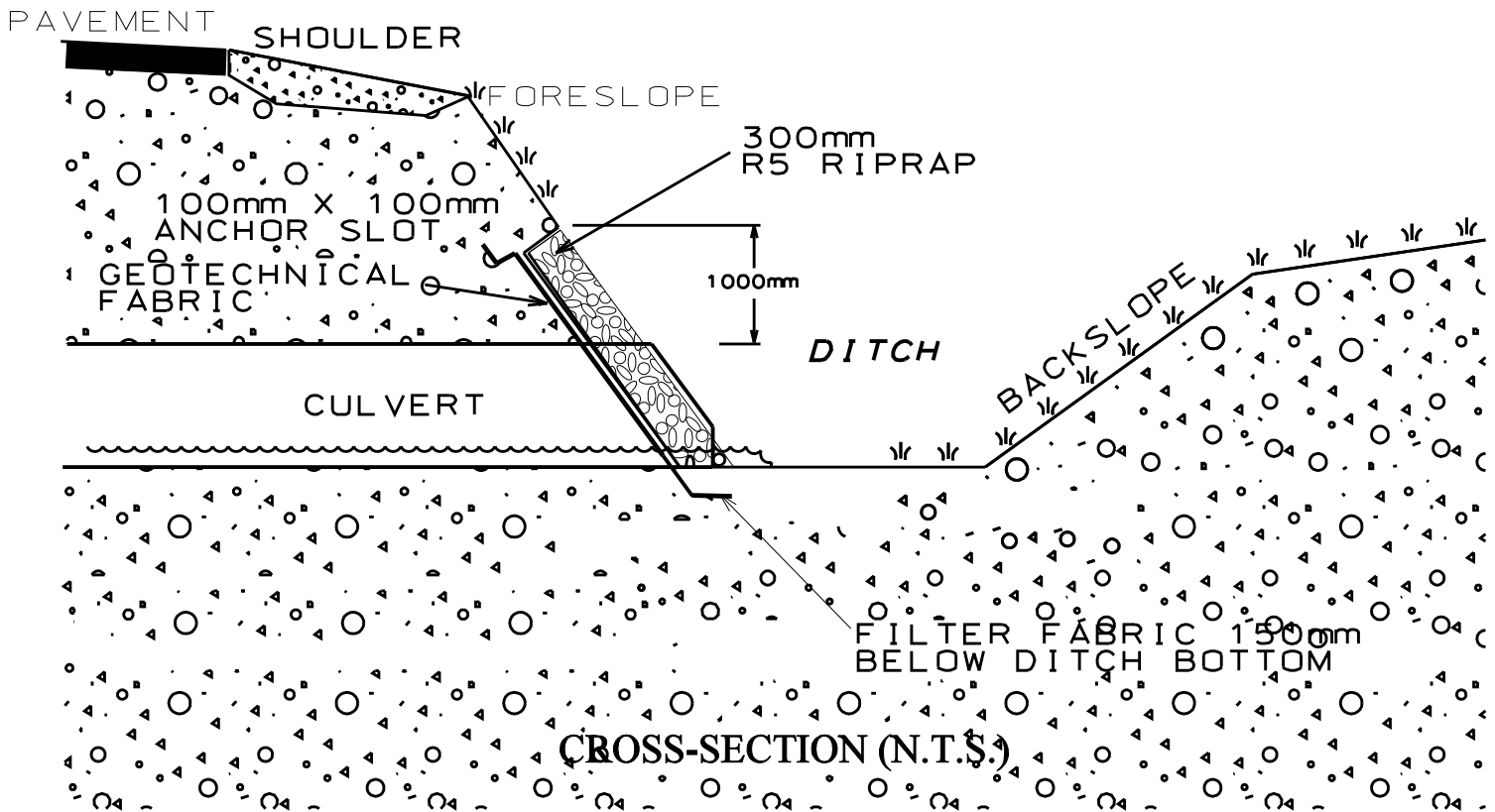

CROSS-SECTION (N.T.S.)

**FIGURE 312-01 CULVERT END TREATMENT (INLET)**  
REVISED 2002

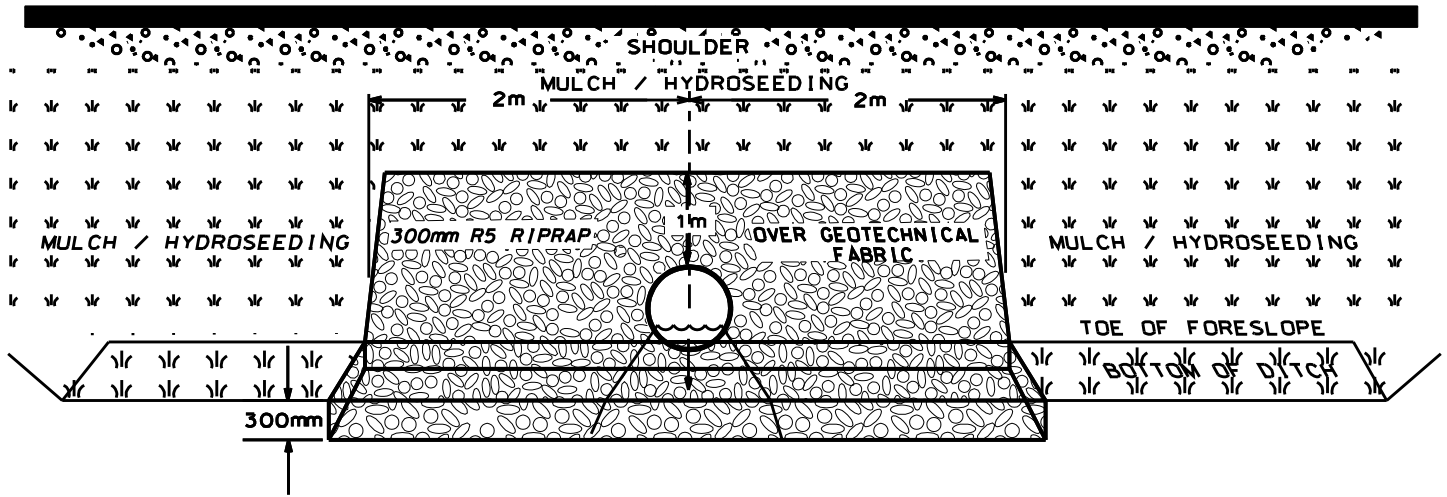

Note: An additional 7m to the left and right of the riprap, as well as above it to the shoulder, shall be mulched. Once fill slope areas are brought to final grade, and the areas are hydroseeded, the areas shall then be remulched.

END VIEW (N.T.S.)

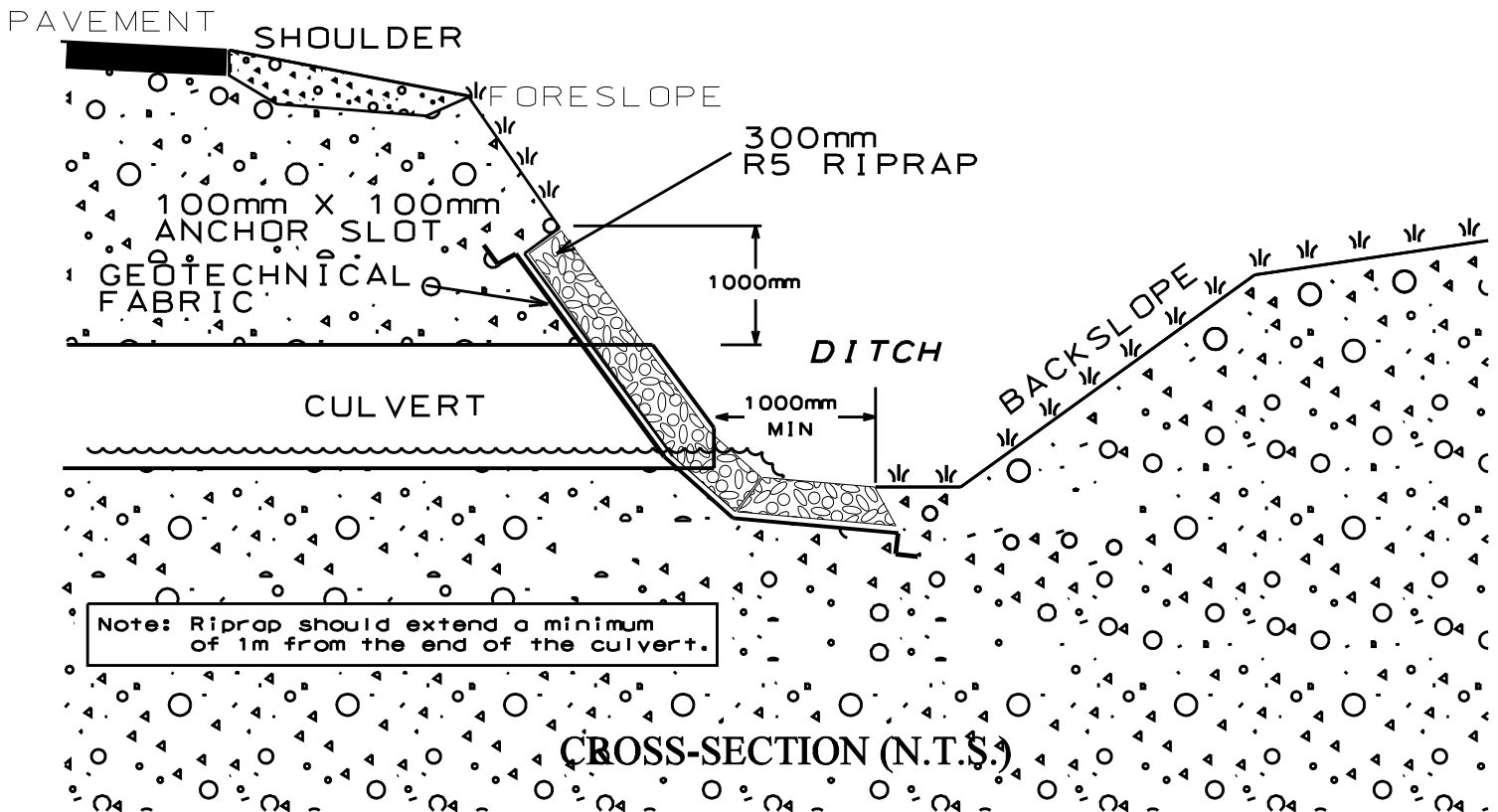

CROSS-SECTION (N.T.S.)

FIGURE 312-02 CULVERT END TREATMENT (OUTLET)

REVISED 2002



**GENERAL PROVISIONS AND CONTRACT SPECIFICATIONS  
FOR HIGHWAY CONSTRUCTION**

DEPARTMENT OF TRANSPORTATION AND PUBLIC WORKS

---

**GRANULAR MATERIAL**

**400**

401 Aggregate

402 Bedding Sand

---

**GENERAL PROVISIONS AND CONTRACT SPECIFICATIONS  
FOR HIGHWAY CONSTRUCTION**

DEPARTMENT OF TRANSPORTATION AND PUBLIC WORKS

---

**AGGREGATE**

**401**

---

401.01 Scope

This Section outlines the source, processing, sampling, testing and quality requirements for aggregates to be incorporated in Department work or stockpiled for Department use.

401.02 Quality of Material

Aggregate shall satisfy all requirements of the specification for the type of material furnished, and unless otherwise specified, shall be one or a blend of the following:

Crushed rock composed of hard, sound, durable, uncoated, cubical fragments of consistent quality produced from non-sedimentary bedrock or non-sedimentary boulders.

Boulders shall be defined in accordance with ASTM D-653 as rock fragments, usually rounded, with an average dimension of 305 mm or greater.

Crushed or uncrushed of naturally formed, hard, sound, durable, uncoated particles of consistent quality, produced from gravel formations.

Aggregate specified in the Tender shall conform to Tables 401-1 and 401-2, and shall be approved by the Engineer. Aggregate shall be free from flat elongated or other objectionable particles and shall be well graded from coarse to fine. The gradings shall not show marked fluctuations from opposite extremes of the limiting sizes and the plotted curve shall flow in a manner free from acute changes in direction.

Blending of acceptable aggregate will be permitted in order to satisfy the gradation requirements for the class of material specified. The blending shall be performed in an approved manner which consistently produces a well graded product. Blending to improve quality will not be permitted except to increase the percentage of crushed particles or decrease the percentage of flat and elongated particles.

Class A material shall be processed by crushing quarried rock. The fine aggregate passing the 4.75 mm Sieve shall consist of resulting particles from the crushing of the coarse aggregate.

Class B material shall be processed by crushing and screening. The fine aggregate passing the 4.75 mm sieve shall consist of particles from the crushing of the coarse aggregate and/or natural sand.

Crushing of Class C material shall not be required.

Class D materials shall be processed by crushing quarried rock.

Class E materials shall be processed by crushing and/or screening.

Aggregates may be rejected based on past field performance regardless of compliance with gradation or physical requirements.

**GENERAL PROVISIONS AND CONTRACT SPECIFICATIONS  
FOR HIGHWAY CONSTRUCTION**

DEPARTMENT OF TRANSPORTATION AND PUBLIC WORKS

**AGGREGATE**

**401**

**Table 401-1 Gradation Requirement for Aggregate**

Sieve Size	Passing by Mass (%)				
	Granular Class A	Granular Class B	Granular Class C	Drainage Class D	Drainage Class E
50.0 mm	-	-	-	100	100
45.0 mm	-	-	100	-	-
38.0 mm	-	-	-	60-100	60-100
31.5 mm	100	100	87-100	50-100	50-100
25.0 mm	95-100	95-100	80-96	35-70	35-70
19.0 mm	-	-	-	20-50	20-50
12.5 mm	50-83	50-83	45-83	10-35	10-35
9.5 mm	-	-	-	5-25	5-25
4.75 mm	30-60	30-60	25-65	0-10	0-10
1.18 mm	15-40	15-43	-	-	-
600 µm	10-32	10-35	-	-	-
300 µm	5-22	5-26	5-22	-	-
75 µm	3-9	3-7	3-10	-	-

Note: The granular Class A and B material shall have a minimum of 13% retained between the 4.75 mm and 600 µm Sieves.  
As tested in compliance with ASTM C-136 and ASTM C-117.

**401.03 Sampling and Testing**

The Engineer shall be notified by the Contractor sufficiently in advance of his intent to deliver aggregate to the Contract indicating his source of supply.

Aggregate shall be randomly sampled as delivered to the Contract and tested to meet the requirements of Table 401-1 and Table 401-2.

Acceptance shall conform to the properties and specified gradation requirements for the class of material specified, as defined in Table 401-1 and Table 401-2, incorporated into the work, and up to the completion of the Contract.

- 1) If the material incorporated into the work does not conform with the specified properties and/or gradation as defined in Table 401-1 and Table 401-2, the Contractor shall cease hauling from the source of supply and shall immediately rectify the problem to the satisfaction of the Engineer.
- 2) Any material found to be non-conforming to the specified material shall be removed from the work.

**GENERAL PROVISIONS AND CONTRACT SPECIFICATIONS  
FOR HIGHWAY CONSTRUCTION**

DEPARTMENT OF TRANSPORTATION AND PUBLIC WORKS

**AGGREGATE**

**401**

If the Contractor's methods results in segregation of the materials as defined by ASTM C-125 and tested in accordance with ASTM C-136 the Contractor shall cease work immediately and correct deficiency.

If segregation of material occurs the Contractor shall scarify and make good the work in place or shall remove the segregated material from the work.

The acceptance of material shall not preclude its future rejection if it is subsequently found to lack consistency or if its field performance is unsatisfactory.

**Table 401-2 Physical Requirements for Aggregate**

Test	Class A	Class B	Class C	Class D	Class E	ASTM
Los Angeles Abrasion, Max. % Loss	35	50	60	50	60	C-131
Magnesium Sulfate Soundness, Max. % Loss	15	-	-	15	-	C-88
Crushed, Min. %	75 <sup>(1)</sup>	50 <sup>(2)</sup>	-	75 <sup>(1)</sup>	-	-
Flat and Elongated, Max. % <sup>(3)</sup>	20	20	-	20	-	-
Plasticity Index	-	-	-	-	-	D-4318
Petrographic Number, Max. <sup>(4)</sup>	150	-	-	150	-	-

- (1) The percent of crushed material will be determined on the fraction of particles by mass retained on the 4.75 mm Sieve having 2 or more mechanically fractured faces.
- (2) The percent of crushed material will be determined on the fraction of particles by mass retained on the 4.75 mm Sieve having 1 mechanically fractured face.
- (3) Flat and elongated particles are those whose greatest mean dimension in the longitudinal axis compared to the least mean dimension in the plane perpendicular to the longitudinal axis exceeds a ratio of 4:1.
- (4) Petrographic number to be determined using current Department test procedures.

**GENERAL PROVISIONS AND CONTRACT SPECIFICATIONS  
FOR HIGHWAY CONSTRUCTION**

DEPARTMENT OF TRANSPORTATION AND PUBLIC WORKS

---

**AGGREGATE**

**401**

---

401.04 Excavation, Processing, Handling and Stockpiling

The Contractor, before commencing excavation of aggregate from any pit, shall comply with Provision 104.15.

The Contractor shall clear and grub pit areas and shall remove and stockpile topsoil and overburden pursuant to Provision 204.02 to prevent infiltration of deleterious matter.

The Contractor shall ensure that the pit is excavated and the aggregate stockpile is constructed in such a manner as to prevent flooding of the materials.

Where necessary, to satisfy the requirements of the type of materials specified, aggregates shall be screened, crushed, washed and otherwise processed with equipment which is of adequate capacity and capable of consistently yielding an acceptable product.

Aggregates shall be washed only in properly designed and constructed washing plants. Truck, mixer or similar washing methods will not be permitted. The water to be used for washing aggregate shall be clean and free from injurious amounts of oil, alkali, acid, organic matter or other deleterious substances. Washed materials or materials excavated from underwater shall be stored for at least 24 hours or longer as determined by the Engineer to allow all free water to drain and to attain a uniform water content.

Aggregates shall be handled, transported and stockpiled in such a manner and with such equipment that segregation and/or contamination is avoided.

Storage areas shall be level, well drained, free of all foreign materials, and of adequate bearing capacity to support the stockpiles. The storage area shall be situated on solid ground with a suitable haul road. Storage areas and haul roads, must withstand heavy equipment and trucks. The Contractor will provide and ensure access for the Department or its agents at any time.

Stockpiles shall be either far enough apart or separated by substantial dividers to prevent intermingling. Stockpiles shall be built up in layers not exceeding 1 m in depth. Each layer shall be completed over the entire area of the stockpile before beginning the next layer. Special attention should be given, that each layer interlocks with the underneath layer. Coning of the piles or spilling of material over the edges will not be permitted. The use of bulldozers is not permitted to construct stockpiles, other than to level spot dumped truck loads or to maintain haul roads.

It is the express responsibility of the Contractor to ensure that stockpiles contain material of acceptable quality and of uniform distribution. Aggregates which are contaminated with foreign matter, segregated or mixed with other aggregates shall not be used and shall be removed from the stockpiles immediately.

The Contractor will provide for weighing of the aggregate in conformity with Provision 107.03.

**GENERAL PROVISIONS AND CONTRACT SPECIFICATIONS  
FOR HIGHWAY CONSTRUCTION**

DEPARTMENT OF TRANSPORTATION AND PUBLIC WORKS

---

**BEDDING SAND**

**402**

402.01 Scope

This Section outlines the gradation requirements for bedding sand to be incorporated in Department work or stockpiled for Department use.

402.02 Quality of Material

Bedding sand shall meet the gradation requirements outlined in Table 402-1. Samples will be taken on a regular basis during the work to ensure that the requirements of Table 402-1 are met.

A minimum of 20% crushed import sand or crushed local stone of equivalent quality must be used to manufacture the bedding sand to meet the specifications of Table 402-1.

**Table 402-1    Gradation Requirement for Bedding Sand**

<b>Sieve Size</b>	<b>Passing (%)</b>
9.5 mm	100
4.75 mm	87-98
2.36 mm	55-95
1.18 mm	30-90
600 µm	10-70
300 µm	0-35
150 µm	0-15
75 µm	0-8

Note:        There shall be a maximum of 35% difference between the percents passing consecutive sieves.

**GENERAL PROVISIONS AND CONTRACT SPECIFICATIONS  
FOR HIGHWAY CONSTRUCTION**

DEPARTMENT OF TRANSPORTATION AND PUBLIC WORKS

---

**BITUMEN**

**500**

501 Asphalt Cement

502 Asphalt Prime

503 Asphalt Emulsions

---

**GENERAL PROVISIONS AND CONTRACT SPECIFICATIONS  
FOR HIGHWAY CONSTRUCTION**

DEPARTMENT OF TRANSPORTATION AND PUBLIC WORKS

**ASPHALT CEMENT**

**501**

501.01 Scope

This Section is the material specification for asphalt cement.

501.02 Quality of Material

Asphalt cement used in carrying out the work shall conform in all respects to the requirements of Table 501-1.

**Table 501-1 Requirements for Performance Graded Asphalt Cement**

Performance Grade	PG 52							PG 58					PG 64					
	-10	-16	-22	-28	-34	-40	-46	-16	-22	-28	-34	-40	-10	-16	-22	-28	-34	-40
Average 7-Day Maximum Pavement Design Temperature °C	<52							<58					<64					
Minimum Pavement Design Temperature °C	> -10	> -16	> -22	> -28	> -34	> -40	> -46	> -16	> -22	> -28	> -34	> -40	> -10	> -16	> -22	> -28	> -34	> -40
<b>Original Asphalt Cement</b>																		
Flash Point Temp, ASTM D92: Minimum (°C)	230							230					230					
Viscosity, AASHTO TP48: Maximum 3 Pas (3000 cP) Test Temp (°C)	135							135					135					
Dynamic Shear, TP5: G'/sinδ, Minimum, 1.00 kPa Test Temp @ 10 rads/s (°C)	52							58					64					
<b>Rolling Thin Film Oven (T240)</b>																		
Mass Loss, Maximum (%)	1.00							1.00					1.00					
Dynamic Shear, TP5: G'/sinδ, Minimum, 2.20 kPa Test Temp @ 10 rads/s (°C)	52							58					64					
<b>Pressure Aging Vessel Residue (PP1)</b>																		
PAV Aging Temperature (°C)	90							100					100					
Dynamic Shear, TP5: G'/sinδ, Maximum, 5000 kPa Test Temp @ 10 rad/sec (°C)	25	22	19	16	13	10	7	25	22	19	16	13	31	28	25	22	19	16
Creep Stiffness, TP1: S, Maximum, 300 MPa — value, Minimum 0.300 Test Temp, @ 60 sec (°C)	0	-6	-12	-18	-24	-30	-36	-6	-12	-18	-24	-30	0	-6	-12	-18	-24	-30



**GENERAL PROVISIONS AND CONTRACT SPECIFICATIONS  
FOR HIGHWAY CONSTRUCTION**

DEPARTMENT OF TRANSPORTATION AND PUBLIC WORKS

---

**ASPHALT CEMENT**

**501**

---

501.03 Method of Measurement

The quantity to be measured for payment under this section shall be the number of tonnes of asphalt cement utilized by the Contractor in producing hot mix asphaltic concrete as determined by calibrated asphalt cement pump metered settings logged by the Department as metered into the mix and calculated for the tonnage of hot mix asphaltic concrete produced.

501.04 Basis of Payment

The supply and transportation of performance grade asphalt cement will be paid for at the Contractor's unit bid price per tonne of asphalt cement. This price shall be full compensation for any and all expenses that may be incurred for the supply, transport and delivery of the performance grade asphalt cement to the Contractor's plant, including the cost of any anti-stripping additive required to meet design mix requirements as well as any storage, heating and handling requirements.

**The unit bid price per tonne of asphalt cement shall be adjusted based on changes to price index of PG Grade 58-28 at the time of closing of tender and the time when the asphalt cement is incorporated into the work. The price index to be used for comparison shall be the price as noted in the "Performance Graded Asphalt Cement Price Index" regularly published by the Ontario Ministry of Transportation.**

The Ontario Price Index can be found at:

[www.raqsb.mto.gov.on.ca/login/raqs.nsf/English/Graphic/viewContractBulletin?OpenForm](http://www.raqsb.mto.gov.on.ca/login/raqs.nsf/English/Graphic/viewContractBulletin?OpenForm)

The payment adjustment will be in dollars per tonne of asphalt binder. A payment adjustment will be established for each month of paving in which the price index for the month differs by more than 5% from the price index for the month in which tenders for the Contract were opened. When the price index differential is less than 5% there will be no adjustment established for that month.

The payment adjustment for the month will be calculated as follows, where:

PA = Payment Adjustment for asphalt binder in dollars  
T = PG asphalt binder price index for the month of Tender Opening  
P = PG asphalt binder price index for month of paving  
Q = Quantity of asphalt binder in tonnes

When  $P > 1.05T$ , the Contractor receives an additional payment from the Owner as follows:

$$PA = (P - 1.05T) \times Q$$

When  $P < 0.95T$ , the Owner deducts from payments due to the Contractor as follows:

$$PA = (0.95T - P) \times Q$$

**GENERAL PROVISIONS AND CONTRACT SPECIFICATIONS  
FOR HIGHWAY CONSTRUCTION**

DEPARTMENT OF TRANSPORTATION AND PUBLIC WORKS

---

**ASPHALT CEMENT**

**501**

---

**Examples:**

1. A Contractors unit bid price for asphalt cement was \$325 for a tender that closed in February. The February price index was \$283.75 and the work was undertaken in May when the price index was \$293.25.

$$0.95(283.75) = \$269.56$$

$$1.05(283.75) = \$297.94$$

Since the price index at time of paving (\$293.25) falls within the 95% to 105% range of the price index at time of tender opening there would be no adjustment to the unit price of the asphalt cement.

2. A Contractors unit bid price for asphalt cement was \$325 for a tender that closed in February. The February price index was \$283.75 and the work was undertaken in June when the price index was \$260.00 and 250t of cement was used.

$$0.95(283.75) = \$269.56$$

$$1.05(283.75) = \$297.94$$

Since the price index at time of paving (\$260.00) falls outside the 95% to 105% range of the price index at time of tender opening an adjustment to the amount paid the Contractor would be required.

The price would be adjusted using the  $P < 0.95T$  formula. Thus the Owner will deduct the following amount from payment to the Contractor:

$$PA = (0.95 \times 283.75 - 260) \times 250 = \$2390.00$$

3. A Contractors unit bid price for asphalt cement was \$325 for a tender that closed in February. The February price index was \$283.75 and the work was undertaken in August when the price index was \$310 and 250t of cement was used.

$$0.95(283.75) = \$269.56$$

$$1.05(283.75) = \$297.94$$

Since the price index at time of paving (\$310.00) falls outside the 95% to 105% range of the price index at time of tender opening an adjustment to the amount paid the Contractor would be required.

The price would be adjusted using the  $P > 1.05T$  formula. Thus the Owner will add the following amount to the payment to the Contractor:

$$PA = (310 - 1.05 \times 283.75) \times 250 = \$3015.00$$

**GENERAL PROVISIONS AND CONTRACT SPECIFICATIONS  
FOR HIGHWAY CONSTRUCTION**

DEPARTMENT OF TRANSPORTATION AND PUBLIC WORKS

**ASPHALT PRIME**

**502**

502.01 Scope

This Section is the material specification for asphalt prime.

502.02 Quality of Material

Asphalt prime emulsion shall conform in all respects to Table 502-1.

Asphalt prime cutback shall conform in all respects to Table 502-2.

**Table 502-1 Requirements for Asphalt Prime Emulsion**

Test	Min.	Max.	ASTM
<b>Tests on Emulsion</b>			
Flash Point Tag Open Cup (°C)	45	-	D-1310
Saybolt Furol Viscosity at 50°C (mm <sup>2</sup> /s)	80	175	D-244
Residue by Distillation (%)	40	-	D-244 <sup>(1)</sup>
Oil Distillate by Volume (%)	-	25	D-244 <sup>(1)</sup>
Storage Stability, 24 hr (%)	-	1.5	D-244
<b>Tests on Residue</b>			
Penetration at 25°C, 100 g, 5 s (0.1 mm)	100	200	D-5
Ductility at 25°C, 5 cm/min (cm)	100	-	D-113 <sup>(2)</sup>
Solubility in Trichloroethylene by Mass (%)	97.5	-	D-2042

- (1) Follow ASTM D-244 except use high temperature distillation thermometer. Bring the final temperature to 360°C and terminate heating immediately.
- (2) If the Ductility at 25°C is less than 100, the material will be acceptable if its Ductility at 15°C is more than 100.

**GENERAL PROVISIONS AND CONTRACT SPECIFICATIONS  
FOR HIGHWAY CONSTRUCTION**

DEPARTMENT OF TRANSPORTATION AND PUBLIC WORKS

**ASPHALT PRIME**

**502**

**Table 502-2 Requirements for Asphalt Prime Cutback**

Test	Min.	Max.	ASTM
Kinematic Viscosity at 60°C (mm <sup>2</sup> /s)	20	35	D-2170
Distillation Tests % of Total to 360°C			
to 190°C (%)	20	80	D-402
to 225°C (%)	-	60	D-402
to 260°C (%)	70	-	D-402
to 315°C (%)	85	-	D-402
Distillation Residue to 360°C, Difference by Volume (%)	50	-	D-402
<b>Tests on Residue</b>			
Penetration at 25°C, 100 g, 5 s (0.1 mm)	80	200	D-5
Ductility at 25°C , 5 cm/min (cm)	100	-	D-113 <sup>(1)</sup>
Solubility in Trichloroethylene by Mass (%)	99.5	-	D-2042

(1) If the Ductility at 25°C is less than 100, the material will be acceptable if its Ductility at 15°C is more than 100.

**GENERAL PROVISIONS AND CONTRACT SPECIFICATIONS  
FOR HIGHWAY CONSTRUCTION**

DEPARTMENT OF TRANSPORTATION AND PUBLIC WORKS

**ASPHALT EMULSIONS**

**503**

503.01 Scope

This Section is the material specification for asphalt emulsions.

503.02 Quality of Material

Asphalt Emulsions used for tack coats shall conform in all respects to the requirements of Table 503-1.

**Table 503-1 Requirements for Tack Coat Material**

Type	SS-1		SS-I h		ASTM
	Min.	Max.	Min.	Max.	
<b>Tests on Emulsion</b>					
Saybolt Furol Viscosity at 25°C (mm <sup>2</sup> /s)	20	100	20	100	D-244
Residue by Distillation (%)	57	-	57	-	D-244
Settlement in 5 days (%)	-	5	-	0.5	D-244
Retention by Mass on an 850 µm Sieve (%)	-	0.1	-	0.1	D-244
Cement Mixing Test (%)	-	2	-	2	D-244
Storage Stability in 24 hr (%)	-	1	-	1	D-244
<b>Tests on Residue</b>					
Penetration at 25°C, 100 g, 5 s (0.1 mm)	100	200	40	90	D-5
Ductility at 25°C, 5 cm/min (cm)	40	-	40	-	D-113
Solubility in Trichloroethylene by Mass (%)	97.5	-	97.5	-	D-2042

**GENERAL PROVISIONS AND CONTRACT SPECIFICATIONS  
FOR HIGHWAY CONSTRUCTION**

DEPARTMENT OF TRANSPORTATION AND PUBLIC WORKS

---

**PAVEMENT**

**600**

---

601 Tack Coat Application

602 Prime Coat Application

603 Hot Mix Asphaltic Concrete

603.01/02 Description & Material

603.03 Mix Design & Job Mix Formula

603.04 Handling of Materials

603.05 Equipment

603.06 Plant Calibrations

603.07 Manufacture of the Mixture

603.08/09 Transportation of the Mixture/Communication

603.10 Seal Course Trial Area

603.11 Requirements for Completed Pavement Courses

603.12 Placing of Asphaltic Concrete

603.13 Construction of Joints

603.14 Compaction

603.15 Profilograph

603.16 Cleanup

603.17/18 Method of Measurement/Basis of Payment

604 Chip Seal

605 Double Emulsified Asphalt Slurry Seal

606 Asphaltic Concrete Curb

607 Asphalt Crack Filling

608 Cold Mix Bituminous Patching Material

---

**GENERAL PROVISIONS AND CONTRACT SPECIFICATIONS  
FOR HIGHWAY CONSTRUCTION**

DEPARTMENT OF TRANSPORTATION AND PUBLIC WORKS

---

**TACK COAT APPLICATION**

**601**

601.01 Description

This work shall consist of the supply and application of a bituminous emulsion as a tack coat on an existing asphaltic concrete surface or on a portland cement concrete surface.

601.02 Material

Tack coat material shall be asphaltic emulsion and shall be in accordance with Section 503.

601.03 Equipment

The distributor shall be so designed, equipped, maintained and operated that asphaltic material at even heat may be applied uniformly on variable widths at readily determined and controlled rates with uniform pressure.

The distributor shall be capable of applying asphaltic material within plus or minus 5% of the desired rate and in a continuous and uniform manner both longitudinally and across the width of the spray bar.

The distributor shall be equipped with a rear mounted spray bar parallel to the surface to be sprayed. The spray bar must be capable of being adjusted in width from 2.5 - 3.7 m.

The spray bar height shall be adjustable and shall be set at such a height that the spray fan from any nozzle overlays the spray fan from the adjacent nozzle by 50% so that a uniformly sprayed surface results.

All spray nozzles shall be in good condition, of the same manufacture, size and type. Nozzles shall have valves capable of instant full opening and positive cut-off. All spray nozzles shall be set in the bar so that the nozzle slots make the same horizontal angle (i.e. 15 - 30°) with the longitudinal axis of the bar.

The distributor shall be equipped with a suitable thermometer with a minimum range of 10 - 150° C, placed to accurately show the temperature of the distributor contents. Tack coat material must be circulated during the entire heating process in the distributor.

The distributor shall be equipped with a tachometer registering m/min that is visibly located to enable the truck driver to maintain constant application speeds at specified rates.

The distributor pump shall be equipped with a tachometer registering l/min passing through the nozzles and shall be readily visible to the operator.

The distributor shall be equipped with an accurate distance measuring device.

The distributor shall be equipped with a sampling valve.

**GENERAL PROVISIONS AND CONTRACT SPECIFICATIONS  
FOR HIGHWAY CONSTRUCTION**

DEPARTMENT OF TRANSPORTATION AND PUBLIC WORKS

---

**TACK COAT APPLICATION**

**601**

601.04 Construction Method

Paved surfaces which are to be covered with hot mix asphaltic concrete shall be tack coated. Surfaces of asphaltic concrete courses which are to be covered by subsequent courses of asphaltic concrete shall also be tack coated.

No tack coat shall be applied in wet weather or when the air temperature is less than 5° C unless otherwise directed by the Engineer.

The surface to be treated shall be cleaned with a power broom, air line, or other approved equipment that will leave a clean, dry surface free from dust, dirt or other objectionable material.

The emulsion shall be heated and maintained at a temperature between 40 - 65° C and shall be applied to the surface at a rate of 0.35 - 0.5 l/m<sup>2</sup> as specified by the Engineer. The emulsion shall be mixed with water to form a 50-50 mixture.

The material shall be applied evenly and shall form a thin unbroken film on the surface.

The application of tack coat shall not extend beyond the limit of asphaltic concrete to be spread and compacted in a day.

At the end of the day tack coat may be applied to accommodate paving operations on the following day.

After applying the tack coat, the Contractor shall, by means of barricades, signallers, traffic convoys or other means, prevent the passage of traffic upon the tack coat until it has dried to a proper condition of tackiness as determined by the Engineer. The Engineer may direct that the Contractor reapply tack coat material to any surface where the original tack coat placed by the Contractor has been worn off by the traffic.

No asphaltic concrete shall be placed upon the tack coat until it has dried to a proper condition of tackiness, as determined by the Engineer. The Contractor is advised that the period required for such drying will depend upon weather conditions; it will not be less than 30 minutes and could be as long as 3 hours.

601.05 Method of Measurement

Measurement for payment under this Section shall be the number of square metres of pavement to which tack coat is applied.

No measurement shall be made for the reapplication of a tack coat which has been worn off by traffic.



**GENERAL PROVISIONS AND CONTRACT SPECIFICATIONS  
FOR HIGHWAY CONSTRUCTION**

DEPARTMENT OF TRANSPORTATION AND PUBLIC WORKS

---

**TACK COAT APPLICATION**

**601**

601.06 Basis of Payment

Payment under this Section shall be at the unit bid price per square metre and this price shall be full compensation for material, heating, handling, transportation, tools, labour, equipment and incidentals necessary to carry out the work.

No payment shall be made under this Section for the reapplication of a tack coat, which may be directed by the Engineer, in the event of traffic wearing off the original application.

**GENERAL PROVISIONS AND CONTRACT SPECIFICATIONS  
FOR HIGHWAY CONSTRUCTION**

DEPARTMENT OF TRANSPORTATION AND PUBLIC WORKS

---

**PRIME COAT APPLICATION**

**602**

602.01 Description

This work shall consist of the supply and application of bituminous prime and sand cover on a previously prepared surface.

602.02 Material

Prime coat material shall consist of an asphaltic emulsion or an asphaltic cutback in accordance with Section 502. Sand cover shall conform to the gradation specified in Table 602-1.

**Table 602-1 Gradation Requirement for Sand**

Sieve Size	Passing (%)
9.5 mm	100
4.75 mm	87-98
2.36 mm	55-95
1.18 mm	30-90
600 µm	10-70
300 µm	0-35
150 µm	0-15
75µm	0-6

602.03 Equipment

The distributor shall be so designed, equipped, maintained and operated that asphaltic material at even heat may be applied uniformly on variable widths at readily determined and controlled rates with uniform pressure.

The distributor shall be capable of applying asphaltic material within plus or minus 5% of the desired rate and in a continuous and uniform manner both longitudinally and across the width of the spray bar.

The distributor shall be equipped with a rear mounted spray bar parallel to the surface to be sprayed. The spray bar must be capable of being adjusted in width from 2.5 - 3.7 m.

The spray bar height shall be adjustable and shall be set at such a height that the spray fan from any nozzle overlays the spray fan from the adjacent nozzle by 50% so that a uniformly sprayed surface will result.

All spray nozzles shall be in good condition, of the same manufacture, size and type. Nozzles shall have valves capable of instant full opening and positive cut-off. All spray nozzles shall

**GENERAL PROVISIONS AND CONTRACT SPECIFICATIONS  
FOR HIGHWAY CONSTRUCTION**

DEPARTMENT OF TRANSPORTATION AND PUBLIC WORKS

---

**PRIME COAT APPLICATION**

**602**

be set in the bar so that the nozzle slots make the same horizontal angle (i.e. 15- 30° ) with the longitudinal axis of the bar.

The distributor shall be equipped with a suitable thermometer with a range of 10 - 150°C, placed to accurately show the temperature of the distributor contents. Prime coat material must be circulated during the entire heating process in the distributor.

The distributor shall be equipped with a tachometer registering m/min that is visibly located to enable the truck driver to maintain constant application speeds at specified rates.

The distributor pump shall be equipped with a tachometer registering ℓ/min passing through the nozzles and shall be readily visible to the operator.

The distributor shall be equipped with an accurate distance measuring device.

The distributor shall be equipped with a sampling valve.

Cover sand shall be spread using an approved spreader.

602.04 Construction Method

Unless otherwise directed by the Engineer any roadway surface which is to be covered with hot mix asphaltic concrete shall be prime coated. The Engineer shall be notified at least 4 hours prior to the start of bituminous priming.

Prime shall not be applied in wet weather or when the air temperature is less than 10°C unless otherwise directed by the Engineer.

The prime shall be heated prior to its application to temperatures between 40 - 55° C for an emulsion and between 27 - 45° C for a cutback.

The prime shall be applied to the surface at the rate of 0.9 - 1.8 ℓ/m<sup>2</sup> as specified by the Engineer. The prime shall be applied evenly and shall form a thin unbroken film at the surface. Following the application of prime, a minimum curing time of 20 minutes shall be provided before a sand cover is applied for the purpose of preventing tracking by vehicles. This sand cover should be applied evenly at a rate not exceeding 12 kg/m<sup>2</sup>. The Engineer can waive the use of sand if conditions permit the Contractor to control traffic so that it can be kept off the primed road until the prime has set up.

After applying the prime coat, the Contractor shall, by means of barricades, flagmen, traffic cones or other means, prevent the passage of traffic upon the prime coat until it has dried to a proper condition of tackiness as determined by the Engineer. The Engineer may direct that the Contractor reapply prime coat material to any surface where the original prime coat placed by the Contractor has been worn off by traffic.

Asphaltic concrete shall not be laid on the primed surfaces within 6 hours of an emulsified prime application and 48 hours after a cutback prime application.

**GENERAL PROVISIONS AND CONTRACT SPECIFICATIONS  
FOR HIGHWAY CONSTRUCTION**

DEPARTMENT OF TRANSPORTATION AND PUBLIC WORKS

---

**PRIME COAT APPLICATION**

**602**

---

602.05 Method of Measurement

Measurement for payment under this Section shall be the number of square metres of roadway to which prime coat is applied.

No measurement shall be made for the reapplications of a prime coat which has been worn off by traffic.

602.06 Basis of Payment

Payment under this Section shall be at the unit bid price per square metre and this price shall be full compensation for material, heating, handling, transportation, application material, tools, labour, equipment and incidentals necessary to carry out the work.

No payment shall be made under this Section for the reapplication of a prime coat, which may be directed by the Engineer, in the event of traffic wearing off the original prime coat.

**GENERAL PROVISIONS AND CONTRACT SPECIFICATIONS  
FOR HIGHWAY CONSTRUCTION**

DEPARTMENT OF TRANSPORTATION AND PUBLIC WORKS

---

**HOT MIX ASPHALTIC CONCRETE - Description & Material**

**603.01/02**

603.01 Description

This Section defines the requirements for the materials, equipment and methods to be followed for production, transportation of hot mixed, hot laid asphaltic concrete for pavement construction and other purposes.

603.02 Material

All materials to be incorporated into the work will be subject to test by the Engineer to determine suitability. Such tests may consist of chemical or physical analysis to determine wearability, soundness, density, stability or any other property pertinent to the satisfactory completion of the work. Acceptance by the Engineer based on the suitability tests shall not relieve the Contractor of the responsibility of maintaining a uniform acceptable product throughout the contract period.

603.02.01 Asphalt Cement

The Contractor shall supply as a bid item performance graded asphalt cement to be incorporated into the Department's work; the asphalt cement shall be PG 58-28 unless otherwise specified and shall conform in all respects to the performance grade requirements of Table 501-1.

When anti-stripping additives are required, the asphalt cement shall meet the specified requirements of Table 501-1, after the addition of the required additives.

The Contractor shall supply the applicable mixing and compaction temperatures for the performance graded asphalt cement specified in addition to the supplier documentation indicating current test results meeting the requirements of Table 501-1 after the addition of required anti-stripping additives if necessary.

The Department will conduct quality assurance testing by testing random samples taken from the Contractor's asphalt cement storage tanks located at the hot mix plant for the purpose of ensuring that the material used in the work conforms to the requirements of Table 501-1.

603.02.02 Mineral Filler

Mineral Filler shall meet the requirements of ASTM D-242.

603.02.03 Asphaltic Concrete Stripping

The Contractor is hereby advised that if their aggregate for asphaltic concrete is moisture susceptible they shall have the option of either using a liquid anti-stripping additive from the Department's list of acceptable products, using hydrated lime, or changing their source of aggregate.

The Department may determine that an anti-stripping additive is required if one of the following conditions occurs:

- The long term tensile strength ratio (TSR) of the asphaltic concrete as per ASTM D-4867 (average of Conditioned & Freeze/Thaw TSR values) is less than 0.80.
- Material that has been conditioned per ASTM D-4867 meets the 0.80 minimum

**GENERAL PROVISIONS AND CONTRACT SPECIFICATIONS  
FOR HIGHWAY CONSTRUCTION**

DEPARTMENT OF TRANSPORTATION AND PUBLIC WORKS

---

**HOT MIX ASPHALTIC CONCRETE - Description & Material**

**603.01/02**

requirement but a visual examination indicates there is evidence of stripping.

- If based on past performance the aggregate source is known to be prone to stripping.

603.02.04 Anti-Stripping Agents

Any anti-stripping agent intended for use shall be incorporated in the mix design in the proportion to be used during production and in accordance with the Manufacturer's Specifications.

The anti-stripping agents shall consist of one of the following:

- Hydrated Lime (Ca(OH)<sub>2</sub>) meeting the requirements of ASTM C-141
- Liquid Anti-Stripping Additives (from the approved list)

<b>Manufacturer</b>	<b>Product</b>
Akzo Nobel Chemicals Akzo Nobel Chemicals	Redicote 95-S Redicote 82-S
Morton International Morton International	Pave Bond "T" Lite Pave Bond Lite
Travis Chemicals Travis Chemicals	Travcor 4501 Travcor 4505
Win Chemicals Ltd.	WinSurf 129-A
ARR-MAZ Products	AD-here LOF 6500

Inclusion on this list does not attest to efficacy of use with any specific aggregate or approval for use on any specific project. Testing for each product shall be required for this purpose. This list is subject to revision.

603.02.04.01 Approval of Anti-Stripping Agents

Approval to use an anti-stripping agent will only be given if it is determined from this testing that the long-term TSR of the mix with an anti-stripping agent equals or exceeds 0.80 and the visual examination indicates there is no evidence of stripping. The Contractor shall also demonstrate the capability of properly adding hydrated lime to the mix at the hot-mix plant if hydrated lime is proposed for use as an anti-stripping agent. In all cases a minimum of 10 working days are required to perform the stripping test after the aggregates have been received by the Materials Lab. An additional 10 working days will be required for re-testing of aggregate with an anti-stripping agent.

**GENERAL PROVISIONS AND CONTRACT SPECIFICATIONS  
FOR HIGHWAY CONSTRUCTION**

DEPARTMENT OF TRANSPORTATION AND PUBLIC WORKS

---

**HOT MIX ASPHALTIC CONCRETE - Description & Material**

**603.01/02**

603.02.04.02 Addition of Liquid Anti-Stripping Additive

The liquid anti-stripping additive shall be added at a rate as determined by the mix design to the asphalt cement at the Supplier's depot, concurrently, with loading of the asphalt cement into the Carriers tanker.

603.02.04.03 Information Sessions

At a pre-construction meeting the Contractor and the Department will review the requirements for use of the liquid anti-stripping additive, including proper procedures, worker information, use of protective clothing and equipment, site supervision and contingency.

The Contractor shall advise workers of the proper procedures to be followed when working with asphalt cement or asphaltic concrete containing anti-stripping additives.

603.02.05 Aggregates

Coarse aggregate to be supplied for the manufacture of asphaltic concrete shall consist of crushed gravel or crushed stone, composed of clean, sound, hard and durable particles free from a coating of silt, and/or clay and shall not contain other deleterious materials. Coarse aggregate shall conform to the physical requirements for coarse aggregate shown in Table 603-1 and 603-2.

Irrespective of compliance with the physical requirements of Table 603-1 and 603-2, a coarse aggregate may be rejected on the basis of past field performance.

Fine aggregate to be supplied for the manufacture of asphaltic concrete shall consist of manufactured material processed by crushing quarried rock or natural sand and gravel, the particles of which shall be clean, hard, durable and free from coatings of silt, clay or other deleterious material. Fine aggregate shall conform to the physical and gradation requirements shown in Table 603-3 and the fraction between any 2 of the following consecutive sieves (4.75 mm, 2.36 mm, 1.18 mm, 600 µm, 300 µm, 150 µm) shall be a minimum of 7 %. A minimum of 25% fine aggregate, processed by crushing quarried rock, shall be incorporated into all asphaltic mixes.

**GENERAL PROVISIONS AND CONTRACT SPECIFICATIONS  
FOR HIGHWAY CONSTRUCTION**

DEPARTMENT OF TRANSPORTATION AND PUBLIC WORKS

**HOT MIX ASPHALTIC CONCRETE - Description & Material**

**603.01/02**

**Table 603-1 Gradation Requirement for Coarse Aggregate - ASTM C-136**

<b>Material Size</b>	<b>9.5 mm</b>	<b>12.5 mm</b>	<b>19.0 mm</b>
<b>Sieve Size</b>	<b>Passing (%)</b>	<b>Passing (%)</b>	<b>Passing (%)</b>
25.0 mm	-	-	100
19.0 mm	-	100	90-100
12.5 mm	100	90-100	50-75
9.5 mm	80-100	45-75	20-55
6.3 mm	15-50	-	-
4.75 mm	0-15	0-15	0-15

**Table 603-2 Physical Requirements for Coarse Aggregate**

<b>Test</b>	<b>A Base</b>	<b>A<sub>L</sub> Base</b>	<b>B Seal</b>	<b>C Seal</b>	<b>C<sub>L</sub> Seal</b>	<b>ASTM</b>
Los Angeles Abrasion, Max. % Loss	35	35	35	35	35	C-131
Magnesium Sulfate Soundness, Max. % Loss	15	15	15	15	15	C-88
Absorption, Max. %	1.7	1.7	1.7	1.7	1.7	C-127
Crushed, Min. %	75	60	75	75	60	(1)
Flat and Elongated, Max. %	20	20	20	20	20	(2)
Petrographic Number, Max.	200	200	140	140	160	(3)
4.75 mm Sieve, Max. % Passing	15	15	15	15	15	C-136
75 µm Sieve with PI < 6, Max. % Passing	3	3	3	3	3	C-117

- (1) Crushed percentage is the fraction of particles by mass retained on the 4.75 mm Sieve having two or more freshly fractured faces for Classes A, B and C, and one fractured face for A<sub>L</sub> and C<sub>L</sub>.
- (2) Flat and elongated particles to be determined using current Department test procedures.
- (3) Petrographic number to be determined using current Department test procedures.



**GENERAL PROVISIONS AND CONTRACT SPECIFICATIONS  
FOR HIGHWAY CONSTRUCTION**

DEPARTMENT OF TRANSPORTATION AND PUBLIC WORKS

**HOT MIX ASPHALTIC CONCRETE - Description & Material**

**603.01/02**

**Table 603-3 Physical and Gradation Requirements for Fine Aggregate**

Test	A Base	A <sub>L</sub> Base	B Seal	C Seal	C <sub>L</sub> Seal	D Sand Seal	ASTM
Magnesium Sulfate Soundness, Max. % Loss	15	15	15	15	15	15	C-88
4.75 mm Sieve, Min. % Passing	85	85	85	85	85	85	C-136
75 µm Sieve, Max. % Passing	9	9	9	9	9	9	C-117

603.02.06 Blending Sand

Blending sand supplied for the manufacture of asphaltic concrete shall consist of clean, tough, durable particles, free of silt, clay or other deleterious material.

The gradation of the blending sand shall be such that when incorporated into the asphaltic concrete mix, the resultant mix shall meet the requirements of Tables 603-4, 603-5 and 603-6.

The blending sand shall have 100 percent passing the 9.5 mm Sieve and a maximum of 50% passing the 300 µm Sieve.

The physical requirements of the blending sand shall be as specified in Table 603-3 with the exception of the limitation on the maximum % passing the 75 µm Sieve.

The maximum mass of blending sand to be used in the total mix shall not exceed 12% for all mixes except "D" mix.

**GENERAL PROVISIONS AND CONTRACT SPECIFICATIONS  
FOR HIGHWAY CONSTRUCTION**

DEPARTMENT OF TRANSPORTATION AND PUBLIC WORKS

---

**HOT MIX ASPHALTIC CONCRETE - Mix Design and Job Mix Formula**

**603.03**

---

603.03 Mix Design and Job Mix Formula

603.03.01 Responsibility for Design Mix

Authority Mix Design

The Engineer shall be notified when stockpiles of coarse aggregate, fine aggregate, blending sand and performance grade asphalt cement representative of the material to be used in the work are available for sampling at the plant site.

The Engineer will arrange for samples of each material to be taken and submitted to the Department's laboratory for mix design purposes after stockpile requirements as specified in Subsection 603.04.01 have been met. The Contractor will be notified of the composition of the mix design no later than three (3) weeks after the day on which all of the representative samples were received by the Department's laboratory. The Contractor shall not commence mix production before such notification.

A new asphalt mix design shall be required if any change occurs in the nature or source of the aggregate and/or the supplier of the performance graded asphalt cement.

Contractor Mix Design

Preparation and submission of the asphalt mix design for the Department's approval is optional to the Contractor. In conformance with this specification, the Contractor shall use professional engineering services and a qualified testing laboratory to assess the performance grade asphalt cement and aggregate materials proposed for use and to carry out the design of the asphalt mix.

603.03.01.01 Requirement for Asphalt Mix Design

The asphalt mix design shall follow the Marshall method of mix design based on 75 Blows and be in accordance with the latest edition of the Asphalt Institute Publication, Mix Design Methods for Asphalt Concrete Manual Series No. 2 (MS-2).

The asphalt cement grade shall be PG 58-28, unless otherwise specified. The optimum percent of asphalt cement shall be that percent which yields design air voids of  $4 \pm 1/2\%$ .

The percent passing the 4.75 mm sieve size  $\pm 2\%$  for the blended aggregate gradations for given mix types shall be as follows:

<u>Mix Type</u>	<u>Percent Passing 4.75 mm sieve size</u>
A, A <sub>L</sub>	50%
B	65%
C, C <sub>L</sub>	60%

**GENERAL PROVISIONS AND CONTRACT SPECIFICATIONS  
FOR HIGHWAY CONSTRUCTION**

DEPARTMENT OF TRANSPORTATION AND PUBLIC WORKS

---

**HOT MIX ASPHALTIC CONCRETE - Mix Design and Job Mix Formula**

**603.03**

---

The mix design data and the proposed job mix formula submitted by the Contractor for the Department's review and approval shall include for each blend the following:

- 1) The name of the testing firm responsible for the mix design.
- 2) The specific location(s) of the source(s) of mineral aggregate.
- 3) The source and type of mineral admixture and the percentage to be used.
- 4) The percentage of aggregate passing each of the specified sieves for each aggregate to be incorporated into the mixture.
- 5) The proportion of each material (in percent of aggregate), including hydrated lime, if required, as an anti-stripping agent.
- 6) The composite gradation based on (4) and (5) above.
- 7) The composite gradation plotted on a 0.45 power graph paper.
- 8) The results of all aggregate testing, determinations, etc., as defined in Tables 603.1, 603.2 and 603.3 of Section 603, of the General Provisions and Contract Specifications for Highway Construction manual, including bulk specific gravity and apparent specific gravity. In addition, aggregates shall be tested to determine if they are prone to stripping (tensile strength ratio <0.8) as well as no visual evidence of stripping. If an anti-stripping additive is required, hydrated lime or an effective liquid anti-stripping agent shall be used.
- 9) The mix design with a minimum of four (4) different asphalt contents (minimum 0.5 % between each point) with at least one point above and one point below the optimum asphalt percentage that reports the following:
  - (i) The percentage (in units of one tenth of 1%) of asphalt cement to beaded, based on the total weight of the mixture.
  - (ii) The Marshall test results for the individual and average bulk specific gravity, stability and flow of at least three specimens at each asphalt content.
  - (iii) The maximum theoretical specific gravity at each asphalt content.
  - (iv) The percent of air voids in the mixture for each asphalt content.
  - (v) The percent voids in mineral aggregate (VMA) at each asphalt content.
  - (vi) The percent voids filled with asphalt (VFA) at each asphalt content.
  - (vii) The design asphalt content as a percent of total mix.
- 10) All Marshall mix design characteristics, including graphs used in arriving at the final mix design, the bulk relative density of the combined aggregates and the asphalt absorption of the combined aggregates.
- 11) The source and current test results of the performance graded asphalt cement to be incorporated into the Department's work meeting the requirements of Table 501-1 for performance graded asphalt cement including applicable mixing and compaction temperatures.

The Contractor shall submit the following with the asphalt mix design for verification purposes:

- (a) One - 20 kg sample of each representative virgin aggregate.
- (b) Thirty-two 1.2 kg samples of representative virgin aggregate blended to the design mix gradation of the asphalt mix aggregate.
- (c) Four Litres of the type of performance grade asphalt cement to be used.

**GENERAL PROVISIONS AND CONTRACT SPECIFICATIONS  
FOR HIGHWAY CONSTRUCTION**

DEPARTMENT OF TRANSPORTATION AND PUBLIC WORKS

---

**HOT MIX ASPHALTIC CONCRETE - Mix Design and Job Mix Formula**

**603.03**

---

603.03.01.02 Design Mix Approval

Design mix approval will be based on the design mix tests and the corresponding requirements detailed in Tables 603.4 and 603.5 of Section 603, of the General Provisions and Contract Specifications for Highway Construction.

The Department's laboratory shall require five (5) working days from the time of receipt of the asphalt mix design and samples to evaluate the asphalt mix design.

As part of the asphalt mix design evaluation, the Department's laboratory shall determine the following properties:

- (i) Combined aggregate gradation;
- (ii) Bulk specific gravity for the asphalt mix aggregate;
- (iii) Marshall density;
- (iv) Theoretical maximum specific gravity of the asphalt mix at the design asphalt content and at each asphalt content considered by the Contractor above and below the design asphalt content.
- (v) The difference between the property values submitted by the Contractor and the property values as determined by the Department's laboratory shall not exceed the amounts shown as follows:

<u>Property</u>	<u>Maximum Permissible Variation</u>
Bulk Specific Gravity of Aggregate	± 0.015
Marshall Density	± 12 kg/m <sup>3</sup>
Theoretical Maximum Specific Gravity	± 0.010

The asphalt mix design shall be rejected if the maximum permissible variations are exceeded.

A new asphalt mix design shall be required if any change occurs in the nature or source of the aggregate and/or the supplier of the performance graded asphalt cement.

The Engineer shall not accept any asphalt mix produced prior to the Contractor receiving written approval of the asphalt mix design.

The approved asphalt mix design specifying the aggregate blend proportions and the design asphalt cement content shall be considered as the job mix formula.

Once the job mix formula has been designated by the Engineer, the Contractor shall be required to produce an asphaltic concrete mixture conforming to the mix control tolerance as specified in Table 603-6.

The mix design and job mix formula shall remain in effect until changed in writing. Should the aggregate source change, or when unsatisfactory results or other conditions make it necessary, a new mix design will be required.

**GENERAL PROVISIONS AND CONTRACT SPECIFICATIONS  
FOR HIGHWAY CONSTRUCTION**

DEPARTMENT OF TRANSPORTATION AND PUBLIC WORKS

**HOT MIX ASPHALTIC CONCRETE - Mix Design and Job Mix Formula**

**603.03**

**Table 603-4 Blended Aggregate Gradation and Asphalt Content for Asphaltic Concrete Mixes**

Sieve Size	Passing (%)					
	A Base	A <sub>L</sub> Base	B Seal	C Seal	C <sub>L</sub> Seal	D Sand Seal
25.0 mm	100	100	-	-	-	-
19.0 mm	90-100	90-100	-	100	100	-
12.5 mm	71-86	71-86	100	90-100	90-100	-
9.5 mm	60-78	60-78	90-100	76-91	76-91	100
4.75 mm	39-61	39-61	55-75	49-72	49-72	85-100
2.36 mm	23-49	23-49	32-60	28-58	28-58	65-85
1.18 mm	16-34	16-34	19-45	19-40	19-40	45-70
600 µm	11-24	11-24	13-35	13-27	13-27	30-55
300 µm	7-16	7-16	8-22	9-18	9-18	15-35
150 µm	5-10	5-10	5-12	6-11	6-11	7-20
75 µm	3.3-6	3.3-6	4.5-6.5	3.7-6	3.7-6	5.5-8
<b>Asphalt Cement</b> % by Mass of Total Mixture	4.7-6.0	4.7-6.0	5.5-7.0	5.3-6.5	5.3-6.5	6.5-8.5

**Table 603-5 Physical Requirements for Dense Graded Asphaltic Concrete**

Test	A Base	A <sub>L</sub> Base	B Seal	C Seal	C <sub>L</sub> Seal	D Sand Seal
Stability at 60°C (N)	5800	4500	5800	5800	4500	3400
Flow (0.25 mm)	8-16	8-16	8-16	8-16	8-16	8-16
Air Voids (%)	3-5	3-5	3-5	3-5	3-5	3-6
Min. VMA (%)	13	13	15	14	14	16
VFA (%)	65-75	65-75	65-75	65-75	65-75	70-85

**Table 603-6 Mix Control Tolerance Variation from Job Mix Formula**

**GENERAL PROVISIONS AND CONTRACT SPECIFICATIONS  
FOR HIGHWAY CONSTRUCTION**

DEPARTMENT OF TRANSPORTATION AND PUBLIC WORKS

---

**HOT MIX ASPHALTIC CONCRETE - Mix Design and Job Mix Formula**

**603.03**

---

Sieve Size	Allowable Variation of % Passing ( $\pm$ %)
25.0 mm	5
19.0 mm	5
16.0 mm	5
12.5 mm	5
9.5 mm	5
4.75 mm	5
2.36 mm	4
1.18 mm	4
600 $\mu$ m	3
300 $\mu$ m	3
150 $\mu$ m	2
75 $\mu$ m	1
Asphalt Cement	0.3

**603.03.02**     Physical Requirements of the Mixture

The mixture shall be uniform and shall consist of a mixture of coarse and/or fine aggregate together with any required blend sand, mineral filler or lime, and mixed with asphalt cement.

The mineral constituents shall be combined in such proportions as to produce a mixture conforming to the gradation requirements of Table 603-4. The grading shall not show marked fluctuations from opposite extremes of the limiting sizes.

Mixtures shall meet the physical requirements of the properties specified in Table 603-5. Current Department test procedures will be used to determine these properties.

**603.03.03**     Mix Control Tolerances

Once the job mix formula has been designated by the Engineer, the Contractor shall be required to produce an asphaltic concrete mixture conforming to the mix control tolerance as specified in Table 603-6.

**GENERAL PROVISIONS AND CONTRACT SPECIFICATIONS  
FOR HIGHWAY CONSTRUCTION**

DEPARTMENT OF TRANSPORTATION AND PUBLIC WORKS

---

**HOT MIX ASPHALTIC CONCRETE - Handling of Materials**

**603.04**

603.04 Handling of Materials

603.04.01 Stockpile Requirements

Stockpiling sites shall be level, well drained, free of all foreign materials and of adequate bearing capacity to support the mass of the stockpiled materials. Stockpiles shall be either far enough apart or separated by substantial dividers to prevent intermingling.

For all aggregates except where stockpiled on Portland cement concrete, asphaltic concrete or on otherwise acceptably stabilized areas, the bottom 150 mm of the stockpile is not to be incorporated into the Department's work.

Stockpiles shall be built up in layers not exceeding 1 m in depth. Each layer shall be completed over the entire area of the stockpile before beginning the next layer. Coning of the piles or spilling of material over the edges of the pile will not be permitted. Traffic over the stockpile surface shall be limited to that required for adequate levelling or removal.

The minimum size of each coarse and fine aggregate stockpile shall be 1000 tonnes. The minimum size of the stockpile(s) of blending materials shall be 150 tonnes.

Before any production of asphaltic concrete mixture has commenced, aggregate stockpiles of the required size and gradation shall be provided at the asphalt plant site. Minimum stockpile requirements shall be maintained throughout the project. Aggregates brought to the site after production has commenced shall be stored in separate stockpiles.

A minimum of 2 working days between the arrival of asphalt aggregate and its incorporation into the asphaltic concrete mixture will be required to facilitate complete analysis of the aggregate prior to its use.

603.04.02 Handling, Feeding and Drying of Aggregate

Aggregate shall be loaded into the cold feed bins so as to prevent the mixing of separated sizes of aggregate. Mixing of materials on site or loading of more than one material into a single bin shall not be permitted.

Where the Contractor chooses to use a batch or continuous mix operation, the aggregate shall be dried and heated in the drier and separated by screening into hot storage bins. When the aggregate is delivered to the mixer, it shall be at a temperature consistent with proper mixing and laying and shall in no case exceed 165°C. Surfaces of dried aggregate shall be free of carbon or unburnt fuel oil.

The aggregate shall be sufficiently dried as evidenced by the lack of noticeable steaming, bubbling, or foaming of the asphalt mixture and the absence of visible free water on the tailgate of the truck box.

If insufficient drying is evident, the Contractor shall take steps as deemed necessary to provide properly dried aggregates.

**GENERAL PROVISIONS AND CONTRACT SPECIFICATIONS  
FOR HIGHWAY CONSTRUCTION**

DEPARTMENT OF TRANSPORTATION AND PUBLIC WORKS

---

**HOT MIX ASPHALTIC CONCRETE - Equipment**

**603.05**

---

603.05      Equipment

603.05.01      Requirement of all Mixing Plants

603.05.01.01      Air Quality Permit Requirements

The Contractor must comply with all applicable sections of the Department's Environmental Protection Plan (EPP) which forms part of these Specifications.

The Contractor must supply all asphaltic concrete from an asphalt plant that has a valid *Air Quality Permit* issued by the PEI Department of Fisheries, Aquaculture, and Environment (FAE).

The Contractor must supply the Engineer with a copy of a valid *Air Quality Permit* for each asphalt plant which will be used to supply asphaltic concrete to the Contractor or project before production begins.

If the Department receives a copy of a written notice from FAE to the Owner of an asphalt plant that the asphalt plant does not possess a valid *Air Quality Permit* or that the *Air Quality Permit* for that plant has been revoked, then the Department will not accept asphaltic concrete from that plant.

603.05.01.02      Inspection Requirements

All equipment shall be on the site and available for inspection, testing and approval before operations commence.

Plants used for the manufacture of asphaltic concrete under this Section shall conform to the requirements of ASTM D-995.

The Engineer, or authorized representative, shall have access at all times to any or all parts of the plant and equipment pertaining to the work. In order to ensure that the manufacture of the mixture is in strict accordance with the specifications, the Department may use whatever recording devices are deemed necessary for permanent records including audio and video records.

Stairways to the mixer platform and to the asphalt cement storage tank manholes, and ladders to other plant units shall provide accessibility to all plant operations. Ample and unobstructed space shall be provided on the mixing platform. A platform shall be provided in the vicinity of the plant to permit inspection and sampling of the mixture before it is delivered to the work site.

603.05.01.03      Equipment for Preparation of Asphalt Cement

Asphalt Cement storage tanks shall be capable of heating the material under effective and positive control at all times and maintaining a range between 130 - 165° C. When the amount of asphalt cement added to the mixture is measured volumetrically, the actual working temperature shall not vary by more than plus or minus 5° C .

A circulating system of adequate size shall be provided for the asphalt cement to ensure proper and continuous circulation between the working tank and the mixer during the entire operating period. A sampling valve shall be between the working tank and the mixer. All pipe lines and fittings shall be insulated to prevent heat loss.



**GENERAL PROVISIONS AND CONTRACT SPECIFICATIONS  
FOR HIGHWAY CONSTRUCTION**

DEPARTMENT OF TRANSPORTATION AND PUBLIC WORKS

---

**HOT MIX ASPHALTIC CONCRETE - Equipment**

**603.05**

---

There shall be a separate tank and circulation line for each grade of asphalt cement being used in the work.

603.05.01.04 Cold Feed System

Bin dimensions and geometry shall be such as to provide a free flow of material at all times. An individual cold feed bin shall be provided for each size, type or aggregate gradation. Each bin shall be equipped with individual gate controls to provide accurate and positive proportioning. Partitions of sufficient height to eliminate intermingling of the aggregate shall be provided between adjoining bins. If the cold feed bins are being fed with a front-end loader, the width of each bin must be at least 500 mm wider than the width of the loader bucket.

A variable speed control shall be permitted only if it is properly designed to give total and proportional control of the cold feed system.

603.05.01.05 Drier

This clause is not applicable to drum mixers.

A rotary drier, of sufficient capacity to heat and dry the aggregate to the required temperature, shall be provided.

603.05.01.06 Screens

This clause is not applicable to drum mixers.

Plant screens capable of screening all aggregates to the sizes required for proportioning each type of asphalt mixture, and capable of handling capacities in excess of the hourly mixer capacity, shall be provided.

All screens shall have square openings, unless otherwise specified by the Engineer. Screens shall be kept clean and in good repair.

603.05.01.07 Hot Aggregate Storage Bins

This clause is not applicable to drum mixers.

The plant shall contain a minimum of two (2) hot aggregate storage bins arranged to ensure separate and adequate storage of appropriate aggregate fractions. Each bin shall be of a size and at a location to prevent material from backing up into other bins. An oversize chute shall be provided to prevent oversize aggregate from becoming incorporated in the mix. Gates on hot storage bins shall be so constructed as to prevent leakage when they are closed.

Each bin shall be provided with a safe and suitable device for obtaining test samples.

603.05.01.08 Asphalt Cement Control Unit

Satisfactory means shall be provided to incorporate the required quantity of asphalt cement into the mixture. All measuring devices shall be sensitive to a one percent (1%) variation above or below the actual mass required. Suitable insulation shall be provided for maintaining the temperature of the asphalt cement in pipelines, meters, weigh buckets, spray bars, containers or flow lines.

**GENERAL PROVISIONS AND CONTRACT SPECIFICATIONS  
FOR HIGHWAY CONSTRUCTION**

DEPARTMENT OF TRANSPORTATION AND PUBLIC WORKS

---

**HOT MIX ASPHALTIC CONCRETE - Equipment**

**603.05**

---

The remainder of this clause is not applicable to drum mixers.

The asphalt cement shall be delivered to the pugmill in a thin uniform sheet or in multiple streams over the full length or width of the mixer.

603.05.01.09 Thermometric Equipment

Suitable thermometric equipment shall be provided to register the temperature of the asphalt as delivered to the mixer. The indicator dial, graduated from 100 - 200°C in 2°C increments, shall be mounted where it is clearly visible to the operator at all times.

Each asphalt cement storage tank shall be equipped with a similarly graduated thermometer installed in the asphalt cement feed line near the mixer's discharge pipe.

Plants shall have approved recording thermometers, pyrometers, or approved recording thermometric instruments at the discharge chute of the drier to register and automatically record the temperature of the heated aggregate. In drum mixers, where the temperature of the hot bituminous mixture is registered and recorded with a printed recorder that can be monitored by the plant operator, the printed record shall be available to the Department.

603.05.01.10 Dust Collectors

This clause is not applicable to drum mixers.

All plants shall be equipped with a primary dry dust collecting system and a wet or dry secondary dust collecting system.

Provisions shall be made to waste all of the collected materials or to uniformly return all or any portion of the dry material to the mixture, as required, to meet mix design.

603.05.01.11 Filler Attachments

Should filler be required in the mixture, the plant shall be equipped with all filler feeding equipment necessary to uniformly incorporate the prescribed proportion of filler into the mixture.

603.05.01.12 Hydrated Lime

Should hydrated lime be required in the mixture, the plant shall be equipped with all feeding equipment necessary to uniformly incorporate the prescribed proportion of lime. The feeding equipment shall be mounted so as to permit thorough dry mixing with the aggregate prior to contact with the asphalt cement.

603.05.01.13 Hot Mix Surge Bins

If the Contractor elects to use a hot mix surge bin, it shall be designed, constructed and operated so that there shall be no segregation of, or damage to, the mix due to the surge bin or its appurtenances. The hot mix surge bin shall be operated in such a manner during draw down to prevent free discharge of hot mix from the conveyor belt to the truck. The maximum allowable time which an asphalt mixture can be stored in a hot mix surge bin shall be 4 hours.

603.05.01.14 Hot Mix Storage Silos

If the Contractor elects to use a hot mix storage silo, it shall be designed, constructed and operated so that there shall be no segregation of, or damage to, the mix. The storage silo shall be equipped with an appropriate holding and batching system at the top of the silo, coordinated with plant production, to prevent complete discharge so that mix is not permitted

**GENERAL PROVISIONS AND CONTRACT SPECIFICATIONS  
FOR HIGHWAY CONSTRUCTION**

DEPARTMENT OF TRANSPORTATION AND PUBLIC WORKS

---

**HOT MIX ASPHALTIC CONCRETE - Equipment**

**603.05**

---

to fall directly into the silo.

Storage silos, equipped with a heating system, shall be capable of maintaining the temperature without localized overheating.

Storage silos shall be equipped with mix level indicators, and when the plant is in continuous operation, the minimum level of mix in the silo must be maintained above the one-third ( $\frac{1}{3}$ ) capacity level.

Storage in the silo up to 20 hours shall be permitted provided:

- (I) that the penetration of the asphalt cement recovered from the stored asphalt concrete is equal to or greater than the penetration after the thin film oven test of the original asphalt cement before mixing, and
- (ii) which, when discharged from the storage silo, was free flowing and without lumps, and
- (iii) which, when delivered to the paver, was at or above 135°C

603.05.01.15 Mix Production Control

At all times during mix production, a Plant Operator, competent and familiar with the operation of the plant, shall be at the control console. The Contractor shall designate a qualified person solely for this operation during the production of asphaltic concrete. The Department reserves the right to reject any mix produced during the Plant Operator's absence.

603.05.01.16 Asphalt Plant Inspector's Quarters

At any asphalt plant the Contractor shall provide, at the Contractor's own expense, working quarters for the Asphalt Plant Inspector having the following dimensions and equipment.

- a) Outside dimension: Min. (3 x 2.4 x 2.4 m).
- b) Equipment:
  - 1 door and padlock
  - 1 window that opens, Min. (700 x 600 mm)
  - 1 chair
  - 1 sturdy and well supported bench along the 3 m wall (700 mm wide x 900 mm high)
  - Electricity: 1 overhead light and at least 1 wall plug
- c) The working quarters shall be located so that the Inspector is able to observe the operation from the building.
- d) This building is to be for the sole use of the Asphalt Inspector. The Contractor is not to store equipment or supplies in it.

603.05.02 Special Requirements for Batch Mixing Plants

603.05.02.01 Material Level Indicators

A material level indicator shall be installed in each hot aggregate bin at the  $\frac{2}{3}$  full level and shall be connected to remote high-low indicator lights mounted at the operator's station.

**GENERAL PROVISIONS AND CONTRACT SPECIFICATIONS  
FOR HIGHWAY CONSTRUCTION**

DEPARTMENT OF TRANSPORTATION AND PUBLIC WORKS

---

**HOT MIX ASPHALTIC CONCRETE - Equipment**

**603.05**

---

603.05.02.02 Weigh Hopper

The equipment shall include a means to accurately weigh each bin size of aggregate in a weigh hopper suspended on scales and this weigh hopper shall be of ample size to hold a full batch without running over. The hopper shall be supported on fulcrums and knife edges and constructed so that the fulcrums and knife edges are not easily thrown out of alignment or adjustment. The hopper shall be dimensioned and constructed to prevent segregation of the dry aggregate prior to mixing. Gates on the hopper shall be constructed to prevent leakage when closed.

603.05.02.03 Plant Scales

Scales for weighing aggregates and asphalt cement shall be the dial type and of a standard make and design. Scales for weighing aggregates shall be accurate and sensitive to 0.5% of the maximum load required, and shall provide a positive means of balancing the tare mass of the hopper and asphalt bucket. At the beginning of each construction season, after each plant set-up and prior to batching any materials, and whenever it is deemed necessary by the Engineer, the Contractor shall verify the accuracy of the scales.

603.05.02.04 Mixer Unit

The plant shall include an approved twin shaft pugmill type batch mixer that can produce a uniform mixture within the tolerances required. The clearance of the blades from the inner surfaces of the pugmill liners shall not exceed 20 mm. The mixer shall be constructed to prevent leakage of the contents. The mixer shall be fitted with separate dry and wet mixing cycle timers and locking devices so that asphalt cement cannot be discharged and the pugmill gate cannot be opened until the desired mixing times have elapsed.

Mixing time shall be determined as the minimum time required to fully coat all aggregate particles with a uniform coating of bitumen.

603.05.03 Special Requirements for Drum Mixers

603.05.03.01 Aggregate Feed System

A positive interlocked automatic shut-off shall be provided so that the plant shuts down automatically after a 15 second disruption in the flow of aggregate from any cold feed bin.

The Contractor shall be responsible for obtaining aggregate moisture contents and adjusting the system accordingly to ensure the correct proportion of asphalt cement and aggregate are maintained.

A vibrating screen of adequate size and capacity shall be provided for oversize material and other debris from the combined cold feed.

The conveyor belt, with the load cell, shall be equipped with a positive means to prevent build-up of material.

603.05.03.02 Asphalt Cement Control Unit

A flow switch shall be installed in the delivery system which will automatically stop the plant if an interruption occurs in the asphalt cement flow.

The asphalt cement metering system shall have provision to compensate for fluctuations in specific gravity and temperature. The Contractor shall be responsible for calculating and adjusting specific gravity values for temperature fluctuations of 5°C or a temperature

**GENERAL PROVISIONS AND CONTRACT SPECIFICATIONS  
FOR HIGHWAY CONSTRUCTION**

DEPARTMENT OF TRANSPORTATION AND PUBLIC WORKS

---

**HOT MIX ASPHALTIC CONCRETE - Equipment**

**603.05**

---

compensating system shall be installed in the asphalt cement line from the storage tank.

A positive means of controlling the delay time between initial aggregate flow and initial asphalt cement delivered shall be employed.

603.05.03.03 Calibration

The asphalt feed system shall be equipped with a calibration system to allow asphalt cement to be bypassed into a container and weighed. The asphalt cement metering system shall be calibrated to an accuracy of plus or minus 1% through the actual working range of the system, at the start of the paving season, whenever the weighing conveyor is moved and whenever deemed necessary by the Engineer.

The aggregate belt scale on the cold feed conveyor shall be calibrated within an accuracy of plus or minus 0.5% through the actual working range of the system at the start of the Contract, whenever the weighing conveyor is moved, and whenever deemed necessary by the Engineer.

603.05.04 Placement Equipment

Pavers shall be self-propelled and capable of laying a consistent, satisfactory mat which is true to the specified geometrics, cross-section and alignment as directed by the Engineer.

The term "screed" shall mean the unit of the paver which strikes off and imparts an initial compaction to the mix.

Pavers shall be equipped with hoppers and distributing screws to place the mixture evenly in front of the screed.

Pavers shall be equipped with screeds and shall be capable of spreading the mixtures, without segregation in thickness from 12 - 200 mm, and in widths to at least 4 m in increments of 250 mm. The screed shall be adjustable to level and crown and shall be heated in an approved manner.

Pavers shall be equipped with automatic longitudinal and transverse grade and slope controls which are capable of being operated from either side of the paver.

The longitudinal grade control shall be adjustable for small mat thickness increments without stopping the paver and shall be equipped to operate from either a 12 m ski or floating beam, a 3 m ski, or a joint matching shoe as required. Where the ski is a flexible unit, it shall be equipped with a spring-tensioned wire extending between brackets fitted on and slightly above each end of the ski. The sensing grid shall ride on the wire and not on the ski.

The term "screed extension" shall mean the section of screed plate, mould board, tamperbar/vibrator and spreading screw which are used to extend the basic screed to the desired paving width.

The term "hydraulic strike-off" shall mean an extension to the mould board and strike-off which can be extended beyond the screed while the paver is operating, to place any strike-off mixtures in narrow transitions or tapers.

Vibrating hydraulic extendable screeds and vibrating bolt-on screed extensions shall be used in placing mat widths greater than three (3) m. Only hydraulic extendable screeds shall be used for paving varying width such as transitions or tapers. Hot overlays using fixed screed extensions shall only be permitted with the approval of the Engineer. All extensions shall provide the same degree of heat and vibration as the main screed. Hydraulic strike-off

**GENERAL PROVISIONS AND CONTRACT SPECIFICATIONS  
FOR HIGHWAY CONSTRUCTION**

DEPARTMENT OF TRANSPORTATION AND PUBLIC WORKS

---

**HOT MIX ASPHALTIC CONCRETE - Equipment**

**603.05**

extensions will not be allowed in the laying of regular or specified mat widths or when placing surface mixture. A three (3) m straight edge shall be provided on each paver. This straight edge shall be of metal or wood.

603.05.05     Compaction Equipment

All rollers shall be of types specifically designed for asphalt compaction.

Rollers shall be in good condition and capable of reversing without backlash. Steel wheeled rollers shall be equipped with a means of supplying a controlled flow of water to the wheels to prevent adhesion of the asphalt mix.

Pneumatic-tired rollers shall be self-propelled with a mechanical means of adjusting the tire inflation pressure. Wheels shall be mounted with smooth tread rubber tires. Approved skirts or windbreaks shall be provided on rollers to protect tires from the cooling air.

All rollers with rubber tires shall be equipped with a means to prevent the asphalt mix from adhering to the rubber tires.

Vibratory rollers shall be equipped with a device that accurately indicates the speed of the roller and the vibrating frequency. All vibratory rollers shall be equipped with an accurate speedometer that indicates speed in increments of one (1) km/hr through the normal operating range. All vibratory rollers shall be equipped with a gauge showing the frequency of vibration per minute when operating in vibratory mode. The frequency of vibration shall not be less than 2200 vibrations per minute. All vibratory rollers shall be capable of automatically stopping the vibrations prior to stopping.

Compaction equipment shall consist of at least one of each of the following:

- a)     Vibratory roller
- b)     Pneumatic tire roller
- c)     Steel-drum tandem finish roller.

603.05.06     Material Transfer Vehicle

Provided a Material Transfer Vehicle (MTV) has been permitted by the Engineer, the Contractor shall be paid a cost per tonne premium, as specified in the Special Provisions for the Contract, for all non-segregated, uniformly textured, smooth asphaltic concrete applied using an approved Material Transfer Vehicle (MTV). The MTV is defined as a self propelled transfer unit capable of both transferring hot asphaltic concrete from an unloading truck to the paving insert hopper and re-mixing the asphaltic concrete before it is transferred. The MTV is not to come in direct contact with the paver.

Areas subject to repairs, as a result of segregation and non-uniform texture or areas subject to negative profilograph price adjustments, will not be eligible for the cost per tonne premium. Repairs, if required, shall be at the Contractor's expense and shall extend the full width and full depth of the mat in which the repair work is performed.

Material Transfer Vehicles (MTVs) which are not approved by the Department will not be eligible for the cost per tonne premium.

**GENERAL PROVISIONS AND CONTRACT SPECIFICATIONS  
FOR HIGHWAY CONSTRUCTION**

DEPARTMENT OF TRANSPORTATION AND PUBLIC WORKS

---

**HOT MIX ASPHALTIC CONCRETE - Plant Calibrations**

**603.06**

---

603.06 Plant Calibrations

The asphalt plant must be calibrated to meet accuracy requirements in accordance with the Department's plant calibration procedures at the commencement of each paving season for permanent plants and at each set-up for portable plants.

The Engineer shall be notified a minimum of 24 hours in advance by the Contractor when the plant is ready for verification of the calibrated system.

Calibration verification of the asphalt plant will occur during the daylight hours only.

The Department, at the discretion of the Engineer, shall randomly check the asphalt plant to ensure the mixture can be produced within the required plant calibration tolerances and if the plant does not meet the required tolerance a re-calibration of the plant may be required.

**GENERAL PROVISIONS AND CONTRACT SPECIFICATIONS  
FOR HIGHWAY CONSTRUCTION**

DEPARTMENT OF TRANSPORTATION AND PUBLIC WORKS

---

**HOT MIX ASPHALTIC CONCRETE - Manufacture of the Mixture**

**603.07**

603.07 Manufacture of the Mixture

603.07.01 Batch and Continuous Mix

For batch and continuous mixing, the mix proportions of the hot aggregate including any blending sand from each individual hot bin, filler and lime when required, and the asphalt cement, shall be measured separately and accurately. In batch mixing, the asphalt cement shall be added after the hot aggregate, and filler and lime when required, had been charged into the mixer and thoroughly dry mixed for at least 15 seconds. Mixing shall be continued for a period of not less than 25 seconds or longer if necessary, to produce a uniform homogenous mixture in which all particles of the mineral aggregate are thoroughly and uniformly coated. In continuous mixing, the mixing period shall be as determined by the formula given in Sub-Provision 603.05.03.04 but not less than 40 seconds and longer if necessary, to produce a uniform homogenous mixture.

The temperature of the mixture as it is discharged from the mixer shall be controlled within plus or minus 5° C of the temperature designated by the Engineer to be consistent with proper mixing and laying and in no case in excess of 160° C.

603.07.02 Drier Drum Mixer

The plant shall not be operated outside the production range established during plant weight cell calibration.

The heating, coating, and mixing of the asphalt mix shall be accomplished in an approved parallel flow drier-mixer. The aggregate shall enter the drum at the burner end and travel parallel to the flame and exhaust gas stream. Heating shall be controlled to prevent fracture of the aggregate or excessive oxidation of the asphalt. The system shall be equipped with automatic burner controls and shall provide for continuous printing of a temperature recording of the bituminous mixture at discharge to be monitored by the plant operator. The printed record of mix temperatures shall also be available to the Department for inspection.

The mixing period and temperature shall produce a uniform mixture in which all the particles are thoroughly coated, and the moisture content of the material as it leaves is 1 % or less. Facilities for sampling and observing the mix at this point shall be provided.

The temperature of the mix immediately after mixing shall not exceed 165° C. The method used to transfer the mixture from the drum mixer to the haulage units shall be designed, constructed and operated so that no segregation of, or damage to, the mix occurs.



**GENERAL PROVISIONS AND CONTRACT SPECIFICATIONS  
FOR HIGHWAY CONSTRUCTION**

DEPARTMENT OF TRANSPORTATION AND PUBLIC WORKS

---

**HOT MIX ASPHALTIC CONCRETE - Transportation of the Mixture/Communication** **603.08/09**

---

603.08 Transportation of the Mixture

The mixture shall be transported from the asphalt plant to the work site in vehicles with smooth metal boxes in good and leak-proof condition and previously cleaned of all foreign materials. Each vehicle shall be equipped with a tarpaulin of canvas or other suitable material. Such tarpaulins shall be on the truck at all times and shall be of sufficient size to overhang the fully loaded truck box and to be tied down on three sides. Tarpaulins shall prevent air flow from contacting the mixture as well as preventing water from entering the truck box. Tarpaulins shall be rolled off the hot mix before the load is dumped into the spreader.

Truck boxes shall be lightly coated with a uniform application of a release agent just before each loading. If liquid agent is used, the truck boxes must be drained after each application and before each loading. All release agents shall comply with occupational health and safety requirements and must not be detrimental to the mix.

Delivery of hot mix to the work site shall be scheduled such that spreading and compacting of the hot mix complies with the time restraints imposed by Provision 106.12. In no case shall temperature be increased at the plant to offset long distance hauling unless authorized by the Engineer in writing.

603.09 Communication Between Road and Plant

Direct communications between the paving operation and the plant shall be the responsibility of the Contractor. Inability to control the delivery of the mixture shall not be cause for the acceptance of work which does not meet the requirements of the Contract, nor shall it relieve the Contractor's responsibility for rejected loads.

**GENERAL PROVISIONS AND CONTRACT SPECIFICATIONS  
FOR HIGHWAY CONSTRUCTION**

DEPARTMENT OF TRANSPORTATION AND PUBLIC WORKS

---

**HOT MIX ASPHALTIC CONCRETE - Seal Course Trial Area**

**603.10**

603.10 Seal Course Trial Area

On projects which require asphaltic concrete type C or type C<sub>L</sub>, the Contractor shall be required to produce seal course mix for sampling and testing before placement commences. At the discretion of the Engineer, the Contractor shall place a minimum of 60 tonnes of seal course mix on a trial area.

The placement of seal course shall be typical of the entire Contract and shall allow the evaluation of the equipment performance under normal operation. Locations such as interchange ramps or intersections are not suitable. The trial area shall be a section which requires a covering seal course mix. Where the base course is 70 mm or greater in thickness the asphalt shall be laid in 2 lifts in the trial area so that the upper lift of 35 mm thickness may be constructed using seal course mix.

The placement of seal course shall not be permitted until the Contractor has demonstrated in the trial area that the materials, equipment, personnel and methods of operation are capable of producing a satisfactory pavement meeting design and specification requirements.

The construction of the trial area may involve moving road equipment back and forth or changing methods of operation or changing plant facilities and operation until the Engineer is assured that the trial area is satisfactory. If deficiencies in the mixture, equipment, operations or end results are indicated, during the construction of the trial area, work on the trial area shall be suspended until the deficiencies are corrected.

No additional payment shall be made to the Contractor for carrying out the operational work necessary for construction of the trial area, as all associated costs are to be included in the Contract unit bid price for seal course.

**GENERAL PROVISIONS AND CONTRACT SPECIFICATIONS  
FOR HIGHWAY CONSTRUCTION**

DEPARTMENT OF TRANSPORTATION AND PUBLIC WORKS

---

**HOT MIX ASPHALTIC CONCRETE - Requirements for Completed Pavement Courses 603.11**

---

603.11 Requirements for Completed Pavement Courses

After final compaction, the surface of each course, and across longitudinal joints other than at a crown, shall be free from deviations exceeding 4 mm as measured with a 3 m straight edge.

Each course after final compaction shall be smooth and true to the required cross-slope and grade. The Contractor shall be responsible for the determination of mix course thicknesses, unless otherwise specified by the Engineer.

The minimum thickness for A and A<sub>L</sub> mixes shall not be less than 50 mm.

The minimum thickness for C and C<sub>L</sub> mixes shall not be less than 35 mm.

The thickness of combined courses shall be within 5 mm of the specified design thickness.

Each course shall be within 0.5% of the specified cross-slope.

Levelling courses shall not be subject to the 5 mm thickness tolerance.

The finished surface of any pavement course shall have a uniform texture and be free of visible signs of poor workmanship.

If the Engineer determines that any load of asphalt concrete is visually unacceptable for reasons of being segregated or the aggregate being improperly coated, it will be rejected for use in the work.

Any obvious defects, as determined by the Engineer, will be cause for rejection of the pavement. Such defects shall include, but not necessarily be limited to, the following:

- (i) Segregated areas;
- (ii) Areas of excess or insufficient asphalt cement;
- (iii) Roller marks;
- (iv) Cracking or tearing;
- (v) Improper matching of longitudinal and transverse joints;
- (vi) Tire marks;
- (vii) Sampling locations not properly reinstated;
- (viii) Improperly constructed patches;
- (ix) Improper cross slope and;
- (x) Fuel spills on the mat.

The Department reserves the right to reject pavement not meeting the requirements of this specification and reserves the right to require that the Contractor replace the pavement at no cost to the Department.

**GENERAL PROVISIONS AND CONTRACT SPECIFICATIONS  
FOR HIGHWAY CONSTRUCTION**

DEPARTMENT OF TRANSPORTATION AND PUBLIC WORKS

---

**HOT MIX ASPHALTIC CONCRETE - Placing of Asphaltic Concrete**

**603.12**

---

603.12 Placing of Asphaltic Concrete

Prior to placing any course of asphalt on a granular grade the Contractor shall ensure that fine grading has been achieved and that the necessary planning with respect to mat widths or transitions has been conducted.

The mixture shall be laid only upon a base which is firm and free from standing water. Not less than 300 m of prepared grade shall be maintained ahead of the paver. This requirement shall be waived at the end of the lane, or at the end of the paving operation for that day. Prior to the delivery of the mix, the prepared base shall be cleaned of all loose or foreign material by the use of a power broom or other suitable means.

Hot mix asphaltic concrete mix shall not be placed unless the air temperature at the surface of the road is 5° C or greater. Under no circumstances will hot mix be placed over a frozen base course or subgrade.

A course shall not be placed upon a previously laid course until at least 12 hours following the final compaction of the previously laid course.

The temperature of the mixture immediately after spreading and prior to initial rolling shall be not less than 125° C.

Immediately after each course is laid and before roller compaction commences, the surface shall be checked and any deficiencies in surface geometrics or texture shall be corrected. Irregularities in alignment and grade along the outside edges shall be corrected before rolling.

The Contractor shall provide competent workmen who are capable of correcting all pavement irregularities.

The mixture shall be dumped in the centre of the spreader hopper and care shall be exercised to avoid over-loading and spillage of the mixture.

The automatic screed controls and all compaction aids on the paver shall be in operation during placing of the mixture unless otherwise directed.

To ensure continuous operation, pavers shall operate at uniform speeds to match the output of the plant provided that a consistent and satisfactory mat is being laid. However, in no case shall the speed of the paver exceed 10 m/min.

The longitudinal alignment of the paver shall be controlled by a string line set from the alignment stakes. The string-line shall be set on the outer edges of the pavement so that the paver is directed at all times by the alignment stakes and not by the edge of the preceding courses.

**GENERAL PROVISIONS AND CONTRACT SPECIFICATIONS  
FOR HIGHWAY CONSTRUCTION**

DEPARTMENT OF TRANSPORTATION AND PUBLIC WORKS

---

**HOT MIX ASPHALTIC CONCRETE - Placing of Asphaltic Concrete**

**603.12**

---

The longitudinal grade of single pavers, or the lead paver shall be controlled by an approved 12 m ski or a 12 m floating beam. Where such a ski is a flexible unit, it shall be equipped with a spring tensioned wire extending between brackets fitted on and slightly above each end of the ski. The sensing grid shall ride on the wire and not on the ski.

When placing a second or subsequent mat using a single paver, joints shall be matched using an approved ski not less than 3 m in length or an approved joint matching shoe, which would ride on the previously placed compacted mat.

Automatic longitudinal grade controls shall be required to be used in combination with transverse slope controls or as otherwise approved by the Engineer.

In narrow base widening, deep or irregular sections, intersections, turnouts or driveways, where it is impractical to spread and finish the base, levelling or seal mixtures by machine methods the Contractor shall spread the mixture by hand. During hand spreading, loads shall not be dumped any faster than they can be properly handled. When it is necessary to hand spread the mixture in areas adjacent to machine laid areas, such hand spreading shall be carried out concurrent with machine laying in order to obtain a good joint.

A mixture which does not comply with the requirements or a mixture which cannot be incorporated in the work shall be rejected. The Department shall charge the Contractor the cost of those materials which are supplied by the Department and that are contained in the rejected work or mixture.

When the Contractor chooses to supply asphaltic concrete to the contract from more than one asphalt plant, the asphaltic concrete mix supplied shall be required to be comprised of aggregates from the same aggregate sources unless otherwise approved by the Engineer.

**GENERAL PROVISIONS AND CONTRACT SPECIFICATIONS  
FOR HIGHWAY CONSTRUCTION**

DEPARTMENT OF TRANSPORTATION AND PUBLIC WORKS

---

**HOT MIX ASPHALTIC CONCRETE - Construction of Joints**

**603.13**

603.13 Construction of Joints

All joints shall be so constructed to ensure a thorough and continuous bond and to provide a smooth riding surface.

All dirt, foreign material and loose material shall be removed from all faces against which joints are to be made.

All faces at which joints are to be made shall be painted with a thin uniform coating of joint painting material, with the exception of joints between adjacent lanes of Mix D. Joints not meeting requirements shall be repaired to the satisfaction of the Engineer.

603.13.01 Requirements for Longitudinal Joints

Joints shall be properly "set up" with the back of a rake or lute at proper height and grade prior to rolling to form a correct, clean and neat joint.

The width of subsequent courses shall be adjusted to an off set of 150-300 mm to ensure that longitudinal joints do not coincide vertically.

When matching a compacted joint, the thickness of the uncompacted mat shall be set to allow for compaction, and the paver shall overlap the adjoining mat by at least 50 mm. After compaction the measured deviation across longitudinal joints other than at the crown shall not exceed 4 mm as measured with a 3 meter straight edge.

603.13.02 Requirements for Transverse Joints with New Asphaltic Concrete

Transverse joints between asphaltic concrete laid under this Contract (i.e. new asphaltic concrete) shall be constructed by cutting a straight vertical face to the full thickness of the proposed lift. Adjacent mats shall be staggered a minimum of 6 m to a maximum of 40 m. The excess material shall be removed to the full thickness of the proposed lift to maintain the required lift thickness.

The paver shall not move more than 20 m from any transverse joint until that joint has been compacted and measured with a straight edge by the Contractor.

Measurements of Transverse Joints shall be taken at right angles to the joint. Joint measurements shall be recorded at the centre and quarter points of the mat width. The 3 m straight edge shall be positioned to record the greatest measured deviation in any of the following positions:

- Extending back 3 m from the joint on the previously placed mat
- Projecting forward 3 m from the joint on the mat being placed.
- Centering the straight edge on the joint.

After compaction, the measured deviation across the transverse joints for A and A<sub>L</sub> mixes shall not exceed 6 mm as measured with a 3 m straight edge. Transverse joints exceeding this measured deviation shall be repaired immediately.

After compaction, the measured deviation across the transverse joints for C, C<sub>L</sub> and D mixes shall not exceed 4 mm as measured with a 3 m straight edge.

**GENERAL PROVISIONS AND CONTRACT SPECIFICATIONS  
FOR HIGHWAY CONSTRUCTION**

DEPARTMENT OF TRANSPORTATION AND PUBLIC WORKS

---

**HOT MIX ASPHALTIC CONCRETE - Construction of Joints**

**603.13**

Transverse joints not meeting the measured deviation requirement shall be repaired to the satisfaction of the Engineer at the Contractor's own expense; the Contractor may be required to meet the measured deviation requirement by cold planing and replacing.

Any joints considered for cold planing and replacing shall be planed the full travel or passing lane width and a minimum of 20 m in length. The depth of cold planing shall be the thickness originally specified for the mix being planed. The entire cold planing and replacing operation shall be done at the Contractor's own expense.

Replacement asphaltic concrete shall be with an approved asphaltic concrete mixture and shall be of the type originally specified.

Materials removed by cold planing shall become the property of the Contractor. The materials shall be hauled and stockpiled in accordance with environmental regulations. All costs associated with the hauling and stockpiling of this material shall be at the Contractor's own expense.

The repaired section shall be in accordance with Section 603.

603.13.03

Requirements for Transverse Construction Joints with Existing Asphaltic Concrete

Joints between asphaltic concrete laid under this Contract and existing asphaltic concrete shall be constructed as follows.

When matching into an existing asphaltic concrete pavement the transverse joint for the first lift shall be prepared by cutting the existing pavement to a straight vertical face and removing such area and depth of the existing pavement as may be necessary to ensure the full depth of asphaltic concrete thickness to be placed.

Successive lifts shall be offset from the previous joint by a minimum of 5 m and shall be prepared by cutting the existing pavement to a straight vertical face and removing such area and depth of the existing pavement as may be necessary to ensure the successive lift thickness.

Adjacent mats on the final lift of asphalt base and on the asphalt seal shall be offset a minimum of 3 m.

**GENERAL PROVISIONS AND CONTRACT SPECIFICATIONS  
FOR HIGHWAY CONSTRUCTION**

DEPARTMENT OF TRANSPORTATION AND PUBLIC WORKS

---

**HOT MIX ASPHALTIC CONCRETE - Compaction**

**603.14**

603.14 General Requirements For Compaction

Compaction equipment requirements shall be as per section 603.05.06, Compaction Equipment Requirements.

In all cases, the production and placement of mixture shall be controlled so that all rolling shall be completed a ½ hour before sunset.

603.14.01 Definitions

Lot: A discrete quantity of material or work to which an acceptance procedure is applied.

Mean (X): The arithmetic average of a group of test measurements.

Random Sample: A sample selected in such a way that every element of the population has an equally likely opportunity to be included in the sample.

Sample: A subset of the lot, measurements on which are used to assess the quality of the lot.

Standard Deviation: The square root of the value found by adding the squares of the individual deviations of each test result from the mean of the test results, and dividing by one less than the number of tests.

603.14.02 Sampling

Pavement sampling will be conducted using the Stratified Random Sampling Procedure. The sampling frequency will be based on lots. A lot will normally be one day's production of each hot mix type. A lot will be terminated when the operation changes from one pavement course to another or moves to a different contract. Each lot will be divided into four approximately equal sublots.

The Engineer, using random numbers, will determine the sample location for each subplot.

Random pavement core samples obtained from each subplot will not be taken within 300 mm of a longitudinal or transverse joint or pavement edge.

Random pavement core samples shall be obtained not later than the next working day after the compaction of the lot.

Each core shall have a minimum nominal diameter of at least 150 mm and a maximum nominal diameter of 200 mm and shall consist of the full layer being sampled.

The Contractor, with approval of the Engineer, may elect to arrange for independent core sampling, in conformance with this specification. Care shall be taken to ensure that cores are not damaged during coring operations or in transit. Core samples shall be delivered within two hours of sampling to the DOT Laboratory for analysis. Holes resulting from the removal of pavement samples shall be repaired to the satisfaction of the Engineer in conformance to the specification.



**GENERAL PROVISIONS AND CONTRACT SPECIFICATIONS  
FOR HIGHWAY CONSTRUCTION**

DEPARTMENT OF TRANSPORTATION AND PUBLIC WORKS

---

**HOT MIX ASPHALTIC CONCRETE - Compaction**

**603.14**

Core samples shall be placed in a suitable container which will protect the sample integrity during transport and until testing. Each sample shall be labelled with the contractor, contract number, highway number, date sampled, mix type, lot number, subplot number, lift number, design lift thickness, station location and offset of the highway.

603.14.03 Determination of Percent Compaction

The percent compaction will be determined by the Department on the random samples using the following procedure:

$$\% \text{ Compaction} = \frac{\text{BRD}}{\text{MMRD}} \times 100$$

Where MMRD = The mean maximum theoretical relative density of the subplot random cores determined by ASTM D2041.

BRD = The bulk relative density of a random core obtained from the lot, determined by ASTM D2726-90 for specimens that contain moisture.

The mean percent compaction for the lot will be determined by calculating the mean of the four subplot random core percent compaction results.

603.14.04.01 Acceptance Procedure

Acceptance for the lot will be based on the lot average compaction.

The lot mean and individual percent compaction value will be reported to one decimal place.

The price adjustment for a given lot based on the lot average method will be determined by reference to the appropriate price adjustment in Table 603.8 provided:

1. Each subplot core shall meet or exceed 90.0% of the mean maximum theoretical relative density for the lot.
2. Each subplot core shall not exceed 97.0% of the mean maximum theoretical relative density for the lot.
3. Rejectable lots/sublots shall be repaired/re-decisioned as per 603.14.04.03.
4. Covered rejectable sublots shall be subject to \$5.00/tonne price adjustment. In addition the rejection limit of 90.0% shall be used for the rejected subplot to calculate the mean lot average for price adjustment for the lot.

**GENERAL PROVISIONS AND CONTRACT SPECIFICATIONS  
FOR HIGHWAY CONSTRUCTION**

DEPARTMENT OF TRANSPORTATION AND PUBLIC WORKS

**HOT MIX ASPHALTIC CONCRETE - Compaction**

**603.14**

**Table 603-8 Price Adjustment Per Tonne Based on Lot Average**

Percent of Maximum Theoretical Relative Density

Lot Average	Price Adjustment Per Tonne
>97.0	Reject
97.0-95.5	0
95.4	\$0.25
95.3	\$0.50
95.2	\$0.75
95.1	\$1.00
95.0-93.5	\$1.25
93.4	\$1.00
93.3	\$0.75
93.2	\$0.50
93.1	\$0.25
93.0-91.6	0
91.5	(\$0.25)
91.4	(\$0.50)
91.3	(\$0.75)
91.2	(\$1.00)
91.1	(\$1.25)
91.0	(\$1.50)
90.9	(\$1.75)
90.8	(\$2.00)
90.7	(\$2.25)
90.6	(\$2.50)
90.5	(\$2.75)
90.4	(\$3.00)
90.3	(\$3.25)
90.2	(\$3.50)
90.1	(\$3.75)
90.0	(\$4.00)
<90.0	Reject

**GENERAL PROVISIONS AND CONTRACT SPECIFICATIONS  
FOR HIGHWAY CONSTRUCTION**

DEPARTMENT OF TRANSPORTATION AND PUBLIC WORKS

---

**HOT MIX ASPHALTIC CONCRETE - Compaction**

**603.14**

603.14.04.02 Retesting

Each sample will be checked for validity in accordance with ASTM E 178-80, Standard Practice for Dealing with Outlying Observations using a "T" test at a 5 percent significance level (two-sided).

- 1) If the outlier test procedure shows that the test result is valid then the test result will be used in the calculations.
- 2) If the outlier test procedure shows that the test result is not valid, the test result will be discarded unless there is an obvious error in the calculations or in transposing of the numbers. If there is no obvious error, a replacement sample shall be obtained for retesting within 300 mm of the original randomly determined core location.
- 3) The test results from the replacement sample will be binding on both the Contractor and the Engineer and will be used in the determination of the mean lot average.

Provided the subplot has not been covered with asphaltic concrete:

- 1) Any subplot subject to rejection will automatically be re-sampled within 300 mm of the original randomly determined core location.
- 2) If this verification sample confirms that the subplot sample is subject to rejection, subsequent samples will be obtained at 20 metre increments. These subsequent samples will be obtained in both directions, within the subplot, in order to establish the extent of the area subject to rejection.
- 3) If the verification sample does not confirm that the subplot sample is subject to rejection, then the verification sample will be substituted for the original subplot sample.

Any subplot which has been covered with asphaltic concrete shall not be retested to:

- 1) Check for validity in accordance with ASTM E 178-80, Standard Practice for Dealing with Outlying Observations using a "T" test at a 5 percent significance level (two-sided).
- 2) Verify rejection or to determine the extent of the rejection area.

The subplot shall be subject to a price adjustment of \$5.00/tonne. In addition the rejection limit of 90.0% shall be used for the rejected subplot to calculate the mean lot average for price adjustment for the lot.

**GENERAL PROVISIONS AND CONTRACT SPECIFICATIONS  
FOR HIGHWAY CONSTRUCTION**

DEPARTMENT OF TRANSPORTATION AND PUBLIC WORKS

---

**HOT MIX ASPHALTIC CONCRETE - Compaction**

**603.14**

603.14.04.03 Repairing And Re-Decisioning

When the Engineer requires a rejectable lot/sublot to be repaired or the Contractor elects to carry out repairs in lieu of accepting a payment adjustment, the Engineer will indicate what areas in the lot are to be repaired.

These areas shall be repaired by removal and replacement or as approved by the Engineers prior to re-decisioning. The minimum width of repair shall be the width of the lane and/or shoulder being repaired. The minimum length shall be sufficient for a paver to be used for carrying out the repair.

When repairs are made to all or parts of a lot the lot shall be re-decisioned. Replacement core samples shall be obtained for all sublots which were subject to rejection. The test results from the replacement samples will be binding on both the Contractor and the Engineer and will be used in the determination of the mean lot average.

**GENERAL PROVISIONS AND CONTRACT SPECIFICATIONS  
FOR HIGHWAY CONSTRUCTION**

DEPARTMENT OF TRANSPORTATION AND PUBLIC WORKS

---

**HOT MIX ASPHALTIC CONCRETE - Profilograph**

**603.15**

---

603.15      Profilograph

603.15.01    Description

The smoothness of the final lift of a newly placed asphaltic concrete will be profiled by the Department using a California Profilograph in accordance with ASTM E-1274, Standard Test Method for Measuring Pavement Roughness. Using a profilograph, profiles will be made approximately at the outer traffic wheel paths of all travel/passing lanes.

The profilograph index for each lane is the cumulative profile reading of the outer wheel path in millimetres per 100 m section, in excess of the 5 mm blanking band.

603.15.02    Full Profile Requirement

The final lift of pavement shall conform to the Profile Index Requirements indicated in Table 603.09, as well the Bump/Dip Profile requirement in Table 603.10.

Pavement sections with a profile Index outside of these indicated as full payment in Table 603.09 shall be subjected to price adjustment as described in 603.09 or repaired in accordance with 603.15.04. Otherwise the maximum price adjustment shall apply as determined by the Engineer.

Individual bump/dips of 8.5mm - 13.4mm as detected by the profilograph shall be subject to price adjustment as described in table 603.10 or the contractor may opt to repair the bumps/dips in accordance with 603.15.04.

Individual bumps/dips that exceed 13.4mm as detected by the profilograph will be cause for rejection of the pavement course and shall be repaired in accordance with 603.15.04, otherwise the maximum price adjustment shall apply as determined by the Engineer.

603.15.03    Bump/Dip Profile Requirements

Individual bump/dips of 8.5mm-13.4mm as detected by the profilograph shall be subject to price adjustment as described in Table 603.10 or the contractor may opt to repair these bumps/dips in accordance with 603.15.04.

Individual bumps/dips that exceed 13.4mm as detected by the profilograph shall be cause for rejection of the pavement course and shall be repaired in accordance with 603.15.04, otherwise the maximum price adjustment shall apply as determined by the Engineer.

603.15.04    Roughness Remedial Measures

Repairs to the work shall be carried out in accordance with section 603 of the General Provisions and Contract Specifications, and within 15 days from the time the contractor receives notification by the Engineer but in no case later than October 15<sup>th</sup>.

If this 15 day period extends past October 15<sup>th</sup>, and repairs that have not been made by October 15<sup>th</sup>, the Contractor shall complete the repairs between June 1 and June 15<sup>th</sup> of the following year.

The Contractor may request smoothness retesting to verify initial Profilograph results at a retesting rate of \$100.00 per hour.

**GENERAL PROVISIONS AND CONTRACT SPECIFICATIONS  
FOR HIGHWAY CONSTRUCTION**

DEPARTMENT OF TRANSPORTATION AND PUBLIC WORKS

---

**HOT MIX ASPHALTIC CONCRETE - Profilograph**

**603.15**

---

The fixed rate shall include all time and equipment required to complete the retesting. Time required for retesting shall include all travel time, including return, from the DOT office in Mt. Stewart or the site of origin for the crew whichever is the least amount, all standby time and all profiling work required to test the work.

The Contractor may opt to repair sections with price adjustments as shown in Table 603.09 and bumps/dips of 8.5mm-13.4mm as shown in Table 603.10.

When the Contractor carries out improvements, including repairs to individual bumps/dips as shown in Table 603.10 or section Subject to Price Adjustment as shown in Table 603.09, the smoothness shall be retested. The Contractor shall be charged for the smoothness retesting at the previously described fixed rate of \$100.00 per hour.

Repair measures by removal and replacement, outerlaying, or rolling shall be approved by the Engineer before the work is undertaken and shall comply with the following:

a) Removal and Replacement

Any section or part thereof considered for removal and replacement shall be cold milled, the travel/passing lane width and for a minimum of 20 metres in length. The depth of cold milling shall be that thickness originally specified for the mix being milled. The entire cold milling and replacing shall be done at the Contractors expense.

Replacement of asphaltic concrete shall be with an approved asphaltic concrete mixture and shall be of the type originally specified. All joints shall be tack coated.

Material removed by cold planing shall become the property of the Contractor. The material shall be hauled and stockpiled in accordance with Environmental Regulations. All costs associated with the hauling and stockpiling of this material shall be incidental to the work.

The repaired section shall be in accordance with Section 603.

b) Overlaying

The overlay shall extend for the full width of the pavement surface. The overlay shall meet all of the requirements of Section 603 and shall be the same asphaltic concrete mix designated as that being overlaid.

Keys shall be constructed on both ends of the overlaid section in accordance with sub-provision 603.13.03.

Repairs by an overlay not meeting this specification shall be rejected and a second overlay will not be permitted. Removal depth shall be sufficient to remove the full thickness of the overlay lift and the original unsatisfactory surface.

c) Rolling

Cross rolling shall be permitted. Should excessive damage occur to the asphaltic concrete due to the rolling the Contractor shall remove and replace the damaged area per section 603.15.04.

**GENERAL PROVISIONS AND CONTRACT SPECIFICATIONS  
FOR HIGHWAY CONSTRUCTION**

DEPARTMENT OF TRANSPORTATION AND PUBLIC WORKS

**HOT MIX ASPHALTIC CONCRETE - Profilograph**

**603.15**

**Table 603-09 Price Adjustment Schedule**

Profile Index Per 100 m Section Profiled Price Adjustment		
Tangent Section and Curves of Radius 600 m or More	Curves of Radius Under 600 m including Transition	Pay Factor per 100 m
0	0	\$150.00
> 0-1	>0-2	\$125.00
> 1-2	> 2-4	\$100.00
> 2-4	> 4-7	\$ 75.00
> 4-6	> 7-10	\$ 50.00
> 6-8	> 10-13	\$ 25.00
> 8-14	> 13-22	\$ 0
> 14-16	> 22-25	(\$ 125.00)
> 16-18	> 25-28	(\$ 250.00)
> 18-20	> 28-31	(\$500.00)
> 20	> 31	(\$2000.00)/Repairs Req'd

**Table 603-10 - Bump/Dip Price Adjustment Schedule**

Bump/Dip Profile Requirements	Price Adjustment
< 8.5 mm	\$ 0.00
8.5 mm - 9.4 mm	(\$ 200.00)
9.5 mm - 10.4 mm	(\$ 500.00)
10.5 mm - 11.4 mm	(\$ 900.00)
11.5 mm - 12.4 mm	(\$1400.00)
12.5 mm - 13.4 mm	(\$2000.000)
>13.4 mm	Repairs Required

**GENERAL PROVISIONS AND CONTRACT SPECIFICATIONS  
FOR HIGHWAY CONSTRUCTION**

DEPARTMENT OF TRANSPORTATION AND PUBLIC WORKS

---

**HOT MIX ASPHALTIC CONCRETE - Cleanup**

**603.16**

603.16 Cleanup

In addition to complying with the terms of Provision 103.04, the Contractor shall thoroughly remove from all bridges, culverts, catch basins, curbs, gutters and other structures asphalt or other work materials.



**GENERAL PROVISIONS AND CONTRACT SPECIFICATIONS  
FOR HIGHWAY CONSTRUCTION**

DEPARTMENT OF TRANSPORTATION AND PUBLIC WORKS

---

**HOT MIX ASPHALTIC CONCRETE - Method of Measurement/Basis of Payment      603.17/18**

---

603.17 Method of Measurement

The quantity to be measured under this Section shall be the number of tonnes of each class of asphaltic concrete acceptably placed.

Cold planing of transverse construction joints shall be measured in accordance with Section 705.

Tack and prime coat applications shall be measured in accordance with Section 601 and 602 respectively.

No measurement shall be made for the remedial work outlined in Sub-Provisions 603.13.02 and 603.15.02.

603.18 Basis of Payment

Payment under this Section shall be at the unit bid price per tonne for each type of hot mix asphaltic concrete and this price shall be full compensation for materials, other than those supplied by the Department; handling, hauling, storing, stockpiling, cutting of existing pavement, painting of joints, mixing, hauling, placing and compacting hot mix asphaltic concrete, tools, labour, equipment, materials and incidentals necessary to complete the work.

Payment for cold planing of transverse construction joints shall be in accordance with Section 705.

No extra payment shall be made for paving intersections, aprons, driveway entrances, extra widths, deep or irregular sections other than the number of tonnes of asphaltic concrete of each class acceptably placed.

Tack and prime coat applications shall be paid in accordance with Section 601 and 602 respectively.

No payment shall be made for the remedial work outlined in Sub-Provisions 603.13.02 and 603.15.02.

**GENERAL PROVISIONS AND CONTRACT SPECIFICATIONS  
FOR HIGHWAY CONSTRUCTION**

DEPARTMENT OF TRANSPORTATION AND PUBLIC WORKS

---

**CHIP SEAL**

**604**

604.01

Description

This Section covers the requirements for the design, surface preparation, application of Bituminous Binder and the supply and application of aggregate for either single or double chip seal surface treatments.

604.01.01

Single Surface Treatment

A single chip seal surface treatment shall consist of a single application of binder followed by a single application of Class E aggregate.

604.01.02

Double Surface Treatment

A double chip seal surface treatment shall consist of a single application of binder followed by a single application of Class E aggregate, and a second application of binder followed by a single application of Class E aggregate.

604.02

Material

604.02.01

Chip Seal Aggregate

The chip seal aggregate must be crushed quarried rock and shall be of high quality and free of soft disintegrated stone, clay or other deleterious materials. The screening and crushing of natural gravel deposits to produce chip seal aggregate shall not be permitted.

The crushed aggregate shall be screened and washed over a 6.35 mm screen. Aggregate shall be washed only in properly designed and constructed washing plants. Truck or mixer washing of aggregates and washing methods of like intent will not be permitted.

Water used for washing aggregates shall be clean and free from injurious amounts of oil, acid, alkali, organic matter or other deleterious substances. Where it is specified that the chip seal aggregate is to be stockpiled, it shall be washed first.

The aggregates shall meet the requirements of Tables 604-1 and 604-2.

Aggregate in stockpiles shall be free of all chlorides.

604.02.02

Asphalt Emulsion

Asphalt emulsion shall be RS-2K or HP-200 and shall meet the requirements of Table 604-3 when delivered to the job site.

**GENERAL PROVISIONS AND CONTRACT SPECIFICATIONS  
FOR HIGHWAY CONSTRUCTION**

DEPARTMENT OF TRANSPORTATION AND PUBLIC WORKS

**Table 604-1 Gradation Requirement for Aggregate**

<b>Sieve Size</b>	<b>Passing (%)</b>	<b>ASTM</b>
12.5 mm	100	C-136
9.5 mm	80-100	C-136
6.7 mm	0 - 43	C-136
4.75 mm	0 - 10	C-136
75 µm	0 - 1.5	C-117

Note: A minimum of 50% of the material in the total gradation must pass the 9.5 mm Sieve and be retained on the 6.7 mm Sieve.

**Table 604-2 Physical Requirements for Aggregate**

<b>Test</b>	<b>Class E</b>	<b>ASTM</b>
Los Angeles Abrasion, Max. % Loss	25	C-131
Magnesium Sulfate Soundness, Max. % Loss	12	C-88
Crushed, Min. % <sup>(1)</sup>	100	-
Flat and Elongated, Max. % <sup>(2)</sup>	20	-
Flakiness Index, Max. (%)	35	-
Petrographic Number, Max. <sup>(3)</sup>	135	-

- (1) The percent of crushed material will be determined on the fraction of particles by mass retained on the 4.75 mm Sieve having two or more mechanically fractured faces.
- (2) Flat and elongated particles are those whose greatest mean dimension in the longitudinal axis compared to the least mean dimension in the plane perpendicular to the longitudinal axis exceeds a ratio of 4:1.
- (3) Petrographic number to be determined using current Department test procedures.

**GENERAL PROVISIONS AND CONTRACT SPECIFICATIONS  
FOR HIGHWAY CONSTRUCTION**

DEPARTMENT OF TRANSPORTATION AND PUBLIC WORKS

**CHIP SEAL**

**604**

**Table 604-3 Requirements for Emulsified Asphalt**

Type	RS-2K		HP-200		ASTM
	Min.	Max.	Min.	Max.	
<b>Tests on Emulsion</b>					
Saybolt Furol Viscosity at 50°C (mm <sup>2</sup> /s)	150	400	50	350	D-244
Residue by Distillation (%)	65	-	65	-	D-244
Settlement in 5 days (%)	-	5	-	3	D-244
Oil Portion of Distillate by Mass (%)	-	3	-	-	D-244
Retention by Mass on an 850 µm Sieve (%)	-	0.1	-	0.1	D-244
Coating <sup>(1)</sup>	-	-	-	-	-
Particle Charge	Positive		Negative		
<b>Tests on Residue</b>					
Penetration at 25°C, 100 g, 5 s (0.1 mm)	100	250	100	200	D-5
Ductility at 25°C, 5 cm/min (cm)	60	-	46	-	D-113
Solubility in Trichloroethylene by Mass (%)	97.5	-	97.5	-	D-2042

(1) Follow ASTM D-244 procedure for wet aggregate except that the limestone aggregate and dust is replaced by the test aggregate. The stone should not be less than 75% coated, both before and after washing.

**604.03 Equipment**

The Contractor shall supply all tools, machinery and equipment required in the execution of all phases of the work. Such equipment shall at all times be maintained in first class working condition and shall at all time be operated by skilled and experienced operators.

**604.03.01 Pressure Distributor**

The pressure distributor used for applying asphalt emulsion shall consist of a fully insulated tank permanently and rigidly mounted on a truck or trailer; that is capable of accurately maintaining any speed required for spraying and capable of applying the binder with plus or minus 5% of the desired application rate.

The distributor shall be provided with the following minimum equipment:

**GENERAL PROVISIONS AND CONTRACT SPECIFICATIONS  
FOR HIGHWAY CONSTRUCTION**

DEPARTMENT OF TRANSPORTATION AND PUBLIC WORKS

---

**CHIP SEAL**

**604**

---

- Hand spray attachments to uniformly apply emulsion to any areas missed by the distributor.
- An efficient and positive means of uniformly heating emulsion and maintaining the contents at a constant selected temperature without local overheating, and a satisfactory method of circulating the contents during the entire heating process.
- An approved thermometer with a minimum range of 10° - 150° C graduated in intervals of not more than 10° C with subdivisions at every 1° C, placed to accurately show the temperature of the distributor contents.
- An approved tachometer, driven from a fifth wheel, mounted so that it is readily visible to the driver. The tachometer must clearly and accurately register distances travelled when spraying emulsion and must allow the driver to maintain the constant speed required to ensure the specified rate of application.
- A bitumen pump tachometer with plus or minus 5% accuracy which registers pump speed.
- A pressure gauge with plus or minus 15 kPa accuracy indicating the pressure in the spray bar.
- A rear mounted adjustable spray bar set parallel to the surface to be sprayed to provide required spraying widths from 2.5 to 3.5 m. The distributor shall be equipped with a spray bar heating device. The distributor shall circulate a uniform viscosity and pressure of the emulsion at each nozzle, both before and during spraying operations. The circulating system shall also have a strainer to prevent clogging of the bar and nozzles. The spray bar height shall be adjustable and shall be set at such a height that the spray fan from any nozzle overlaps the spray fan from the adjacent nozzle by 50% to ensure a uniformly sprayed surface. Spray bar height adjustment shall be made by the height set when the distributor is ½ full.
- Spray bar nozzles shall be designed and set to ensure uniform fan shaped sprays. The nozzles shall not produce such a fine mist that the emulsion will blow away resulting in a non-uniform emulsion coating. All spray nozzles shall be of the same manufacture, size, type and in good condition and shall be provided with valves capable of instant full opening and positive cut-off. All spray nozzles shall be set in the bar so that the nozzle slots make the same horizontal 30° angle with the longitudinal axis of the bar. Before work commences and periodically as required during spraying operations, the nozzles on the spray bar shall be removed and immersed in a solvent for a period of time sufficient to remove all congealed asphalt.
- A strainer shall be provided in the filling line to prevent entry of foreign material into the tank.
- A sampling cock fitted on the spray bar or circulating line is required to allow samples of the emulsion to be obtained directly from the distributor.

**GENERAL PROVISIONS AND CONTRACT SPECIFICATIONS  
FOR HIGHWAY CONSTRUCTION**

DEPARTMENT OF TRANSPORTATION AND PUBLIC WORKS

---

**CHIP SEAL**

**604**

604.03.02     Mechanical Aggregate Spreader

The self-propelled aggregate spreader shall be capable of continuously and uniformly spreading closely regulated quantities of aggregate within plus or minus 10% of the application rate selected.

The spreader shall be equipped with a rear-mounted aggregate hopper. The spreader shall be equipped with a front hopper and an approved means of transferring the aggregate to this hopper from the rear. The front hopper shall be equipped with an oversize reject screen and metering gauges. The gates shall adjust the spreading width and shall be adjustable to obtain a uniform flow of aggregate across the spreading width. These gates shall also be designed to provide simultaneous movement or closure from the operator's position. The flow of aggregate from the metering gates shall be further controlled by a spread roller, the rotation of which shall automatically commence when the metering gates are opened.

604.03.03     Rollers

Steel-tired rollers shall have tandem wheels and weigh at least 7 tonnes and shall exert a pressure on the compression roll of at least 3.5 kg/mm per roll width. Pneumatic-tired rollers shall be self-propelled and have a minimum ballasted weight of 8 tonnes. A minimum of 2 pneumatic-tired rollers shall be used on each section of work.

604.03.03     Mechanical Broom

Shall be of an approved type suitable for pavement use.

604.04         Construction

604.04.01     Qualifications of Contractor

To be eligible as a bidder, the Contractor must have had previous experience of the application of chip seal of a similar nature in similar climatic conditions.

The Contractor's foreman on this project shall have a minimum of 3 years experience.

604.04.02     Design

The Contractor shall assess the roadway surface condition and design the required application rates for binder and aggregate for either single or double chip seal treatments. A copy of which shall be forwarded to the Engineer.

604.04.03     Guarantee

The Contractor will be required to guarantee the work and associated items for a period of 1 year after completion against all defects, due either to defective workmanship and/or material. Any repairs required will be carried out expeditiously at the Contractor's own expense.

**GENERAL PROVISIONS AND CONTRACT SPECIFICATIONS  
FOR HIGHWAY CONSTRUCTION**

DEPARTMENT OF TRANSPORTATION AND PUBLIC WORKS

---

**CHIP SEAL**

**604**

---

604.04.04     Inspection

The Engineer will have the right to inspect all or any of the materials at source, manufacture or storage. The Contractor will arrange for the Engineer to have the right of access to the supplier's premises for purposes of inspection.

604.04.05     Surface Preparation

Before chip seal operations commence the contractor shall completely clean the pavement of all dirt and other debris. Cleaning shall be by the use of a power broom. Should there be any depressions not completely cleaned with the power broom, then the Contractor shall clean such spots with a hand broom.

604.04.06     Pavement Restoration and Crack Filling

Pavement restoration and crack filling shall be carried out to repair pavement pot-holes and cracks prior to the carrying out of the chip seal surface treatment operations.

The pavement restoration shall be in accordance with Section 709. Crack filling shall be in accordance with Section 607.

604.04.06.01   Trail Areas

When required by the Engineer, trial areas shall be used to establish the correct rates of application of binder and aggregate. A trial area shall be at least 100 m long and 1 lane wide. The rates of application of the binder and aggregate shall be determined by carefully measuring the contents of the distribution before and after spraying the trial area and by carefully measuring the quantity of aggregate applied.

604.04.07     Application of Emulsion

All required patching and crack filling shall be carried out to the satisfaction of the Engineer, at least 24 hours prior to chip seal emulsion application.

The emulsion shall be applied at a temperature in the range 60 - 80° C.

The emulsion shall be applied at the design rate as designed for either single or double chip seal treatments. For any given area the emulsion shall be applied at the rate designed by the Contractor.

During the application of the emulsion, the distributor shall be operated by a minimum of 2 men, one of whom shall be stationed on the rear platform, to control the application. The forward speed of the distributor shall not exceed 1.6 m/s.

**GENERAL PROVISIONS AND CONTRACT SPECIFICATIONS  
FOR HIGHWAY CONSTRUCTION**

DEPARTMENT OF TRANSPORTATION AND PUBLIC WORKS

---

**CHIP SEAL**

**604**

604.04.08      Application of Aggregate

The crushing and stockpiling of chip seal aggregates must be 100% complete prior to application to the road surface.

The aggregate shall be uniformly distributed at the application rate designed by the Contractor for both single and double chip seal treatments.

The aggregate application operation shall be coordinated with the emulsion application so that no more than 30 m separates the emulsion application and the aggregate spreading.

Application of aggregate operations for the day shall be completed at least 2 hours before sunset.

604.04.09      Rolling

Immediately after the application of the aggregate, pneumatic-tired rolling shall be carried out in such a manner that the entire treated area received at least 2 passes. Final rolling shall consist of 1 pass of a steel wheel roller.

The rollers shall be operated at such a speed that there is no aggregate pick up but in no case shall the speed of the rollers exceed 10 km/hr.

All rolling shall be completed with 30 m of the aggregate spreader. Initial rolling shall occur within 1 minute of the application of the aggregate.

The minimum number of rollers required is 2 pneumatic-tired rollers and 1 steel roller. If this combination of rollers is not sufficient to maintain the completed rate of progress additional rollers shall be provided.

604.04.10      Mechanical Brooming

The chip seal treated surfaced shall be swept with a power broom. All excess aggregate shall be removed and disposed of by the Contractor, at the Contractor's own expense. Sweeping shall not be carried out until the treatment has set to a sufficient degree so that the chip seal is not damaged.

On chip seal treated surfaces open to traffic, power brooming shall be carried out within 48 hours of the application of aggregate.

604.04.11      Temperature and Weather

Chip seal operations shall not be carried out when, in the opinion of the Engineer, road conditions, high humidity, imminence of rain, wetness or dampness are present.

Asphalt emulsion application operations shall not be carried out when the air temperature is less than 15° C.

Chip seal treatment shall not be carried out before June 1 or after September 1, unless otherwise directed by the Engineer.



**GENERAL PROVISIONS AND CONTRACT SPECIFICATIONS  
FOR HIGHWAY CONSTRUCTION**

DEPARTMENT OF TRANSPORTATION AND PUBLIC WORKS

---

**CHIP SEAL**

**604**

604.04.12     Protection of Work and Traffic Control

When possible, the traffic shall be kept off the treated surface until the chip seal is resistant to damage. When traffic must go over the surface before it is fully cured, the Contractor shall control traffic speed by means of directing the traffic in convoys. The Contractor shall provide a lead vehicle to ensure that convoys proceed at low speed. Traffic control is to be maintained until power brooming has been completed.

604.05     Method of Measurement

Measurement for payment under this Section shall be the number of square metres of acceptable chip seal applied.

Measurement for pavement restoration shall be in accordance with Section 709.

Measurement for crack filling shall be in accordance with Section 607.

604.06     Basis of Payment

Payment for chip seal shall be at the unit bid price per square metre and this price shall be full compensation for labour, materials, equipment, roadway surface preparation, supply and application of asphalt binder, supply and application of aggregate, rolling, power brooming, traffic control, royalties and incidentals necessary to perform the work.

No compensation other than the Contract price shall be made for variations in the rate of application or for the treatment of any areas, as required by the Engineer.

Payment for pavement restoration shall be in accordance with Section 709.

Payment for crack filling shall be in accordance with Section 607.

**GENERAL PROVISIONS AND CONTRACT SPECIFICATIONS  
FOR HIGHWAY CONSTRUCTION**

DEPARTMENT OF TRANSPORTATION AND PUBLIC WORKS

---

**DOUBLE EMULSIFIED ASPHALT SLURRY SEAL**

**605**

605.01 General

605.01.01 Scope

This Section covers the requirements for the design, testing, surface preparation, traffic control and quality control required for the proper application of a double emulsified asphalt slurry seal.

605.01.02 Description

The slurry seal shall consist of a mixture of an approved emulsified asphalt, mineral aggregate, water and specified additive. The slurry seal mix shall be proportioned, mixed and uniformly spread over a properly prepared surface. The completed slurry seal shall be a homogeneous mat, adhered firmly to the prepared surface and with a skid resistant surface texture.

605.01.03 Applicable Specifications

The following specifications and all test methods therein dealing with mineral aggregates, mineral filler and slurry seal form a part of this specification:

American Society for Testing Materials and International Slurry Seal Association.

All material, equipment and construction procedures shall conform, unless otherwise directed, to the "Recommended Slurry Seal Surface" published by the International Slurry Seal Association except as modified by the requirements of this project specification.

605.01.04 Qualifications of Contractor

The Contractor must have had previous experience on the application of slurry seal of a similar nature in similar climatic conditions. The Contractor must list at least 5 similar jobs which on investigation will prove to have been completed in a satisfactory manner.

The Contractor's foreman on this project shall have a minimum of 3 year's experience on similar projects.

605.01.05 Guarantee

The Contractor will be required to guarantee the work and all associated items for a period of 1 year after contract completion date against all defects, due either to defective workmanship and/or materials. Any repairs required will be carried out expeditiously at the Contractor's own expense.

**GENERAL PROVISIONS AND CONTRACT SPECIFICATIONS  
FOR HIGHWAY CONSTRUCTION**

DEPARTMENT OF TRANSPORTATION AND PUBLIC WORKS

---

**DOUBLE EMULSIFIED ASPHALT SLURRY SEAL**

**605**

605.01.06     Inspection

The Engineer will have the right to inspect all or any of the work materials at the source, manufacture or storage. The Contractor will arrange for the Engineer to have the right of access to the supplier's premises as may be necessary for the purpose of inspection.

605.01.07     Mix Design

The Contractor shall assess the contract roadway surface condition.

All materials shall be pretested by a qualified materials testing firm as to their suitability for use in slurry seal. A complete laboratory analysis and mix design, including the Wet Track Abrasion Test shall be submitted to the Engineer prior to commencement of the work.

605.02     Material

The emulsified asphalt shall conform to the requirements of ASTM D-2397 for CSS-1H emulsion type.

The mineral aggregate shall consist of manufactured crushed quarried rock such as granite, or other high quality aggregate. The aggregate shall be clean and free from vegetable matter and other deleterious substances.

When tested according to ASTM C-131, the aggregate shall show an abrasion loss of not more than 25%. When tested according to ASTM C-88, the aggregate shall show a loss of not more than 15% by use of magnesium sulphate.

Mineral filler in the form of normal Portland cement shall be considered part of the blended aggregate and shall be used in the proportion determined by the mix design.

When tested by ASTM C-136 and ASTM C-117, the aggregate and mineral filler shall meet the gradation of Table 605-1 as specified by the International Slurry Seal Association.

All water shall be potable and compatible with the slurry mix. Compatibility must be insured by the Contractor.

Additives may be used to accelerate or retard the break-set of the slurry seal or improve the finished surface. The use of additives in the slurry mix or in individual materials shall be made initially in quantities predetermined by the mix design with field adjustments, if required, after approval by the Engineer.

605.03     Equipment

All equipment, tools and machines used in the performance of this work shall be maintained in satisfactory working order at all times.

The slurry seal mixing equipment shall be a continuous flow mixing unit. The unit must have suitable means of accurately metering each individual material being fed into the mixer. All feeding mechanisms must be continuous feed and proportioning must remain constant at all times. The unit shall be equipped with approved devices so that the machine can be

**GENERAL PROVISIONS AND CONTRACT SPECIFICATIONS  
FOR HIGHWAY CONSTRUCTION**

DEPARTMENT OF TRANSPORTATION AND PUBLIC WORKS

---

**DOUBLE EMULSIFIED ASPHALT SLURRY SEAL**

**605**

accurately calibrated and the material quantities of materials used during any period can be estimated.

The spreader box shall be equipped to prevent loss of slurry seal from all sides and shall be equipped with a flexible rear strike-off. It shall be capable of producing a uniform surface its full width and shall be equipped with hydraulically-powered augers to keep the slurry in motion and to help keep the mixture uniformly spread across the spreader box width.

Suitable crack and surface cleaning equipment, barricading equipment, hand tools and any support equipment shall be provided as necessary to perform the work.

**Table 605-1 Gradation Requirement for Aggregate and Mineral Filler**

Sieve Size	Type II - Passing (%)
9.5 mm	100
4.75 mm	90-100
2.36 mm	65-90
1.18 mm	45-70
600 µm	30-50
300 µm	18-30
150 µm	10-21
75 µm	5-15

605.04 Construction

605.04.01 Traffic Control

The Contractor will be responsible for all traffic control.

Suitable methods, including directing the traffic in convoys shall be used by the Contractor to protect the slurry seal from traffic until the new surface will support the traffic without damage. Opening to traffic does not constitute acceptance of the work. The Engineer shall be notified of the methods to be used.

Any damage to the new surface during the curing period done by traffic or the Contractor's equipment will be repaired at the Contractor's own expense.

**GENERAL PROVISIONS AND CONTRACT SPECIFICATIONS  
FOR HIGHWAY CONSTRUCTION**

DEPARTMENT OF TRANSPORTATION AND PUBLIC WORKS

---

**DOUBLE EMULSIFIED ASPHALT SLURRY SEAL**

**605**

605.04.02     Weather Limitation

The slurry seal shall not be applied if either the pavement or air temperature is below 15<sup>o</sup> C and falling, but may be applied when both pavement and air temperatures are above 10<sup>o</sup> C and rising. No slurry seal shall be applied when there is danger that the finished product will freeze before 24 hours. The mixture shall not be applied when weather conditions prolong traffic opening to beyond a reasonable time.

605.04.03     Surface Preparation

Immediately prior to applying the slurry seal, the surface shall be cleared of all loose material, silt spots, vegetation, oil spots and other objectionable material. Any standard cleaning method will be acceptable. If water is used, cracks will be allowed to dry thoroughly before slurry sealing. The Engineer shall approve the surface preparation prior to sealing.

605.04.04     Application of the Slurry Surface

The surface shall be pre-wetted by fogging ahead of the slurry box when in the opinion of the Engineer, it is required by local conditions. Water used in pre-wetting the surface shall be applied such that the entire surface is damp with no apparent flowing water in front of the slurry box. The rate of application of the fog spray shall be adjusted during the day to suit temperatures, surface texture, humidity and pavement surface dryness.

The slurry mixture shall be of the desired consistency when deposited on the surface and no additional elements shall be added. A sufficient amount of slurry shall be carried in all parts of the spreader at all times so that complete coverage is obtained. No lumping, balling or unmixed aggregate shall be permitted. No segregation of the emulsion and aggregate fines from the coarse aggregate will be permitted. If the coarse aggregate settles to the bottom of the mix, the slurry will be removed from the pavement. No excessive breaking of the emulsion will be allowed in the spreader box. No streaks caused by oversized aggregate will be left in the finished pavement.

605.04.05     Joints

No excessive build-up or unsightly appearance shall be permitted on longitudinal or transverse joints.

605.04.06     Handwork

Areas which cannot be reached with the slurry seal machine shall be surfaced using hand squeegees to provide complete and uniform slurry seal coverage. The area to be hand worked shall be lightly dampened prior to mix placement and the slurry shall be worked immediately. Care shall be exercised to leave no unsightly appearance from hand work. The same finish as applied by the spreader box shall be required. Hand work shall be completed during the machine applying process.

**GENERAL PROVISIONS AND CONTRACT SPECIFICATIONS  
FOR HIGHWAY CONSTRUCTION**

DEPARTMENT OF TRANSPORTATION AND PUBLIC WORKS

---

**DOUBLE EMULSIFIED ASPHALT SLURRY SEAL**

**605**

605.05      Method of Measurement

Measurement for payment under this Section shall be the number of square metres of acceptable slurry seal.

605.06      Basis of Payment

Payment for slurry seal surface treatment shall be at the unit bid price per square metre of application and this price shall be full compensation for materials, preparation, mixing, application, labour, equipment, tools, test mix design, traffic control and incidentals to complete the work.

No compensation other than the Contract price shall be made for variations in the rate of application or for the re-treatment of any areas, as required by the Engineer.

**GENERAL PROVISIONS AND CONTRACT SPECIFICATIONS  
FOR HIGHWAY CONSTRUCTION**

DEPARTMENT OF TRANSPORTATION AND PUBLIC WORKS

---

**ASPHALTIC CONCRETE CURB**

**606**

606.01 Description

This work shall consist of the manufacture and placement of asphaltic concrete curb in accordance with the Plans or as directed by the Engineer.

606.02 Material

The hot mix, hot placed asphaltic concrete shall meet the requirements for asphalt curb and shall be approved by the Engineer prior to placing. The liquid asphalt cement shall be supplied by the Contractor.

606.03 Construction

The hot mix, hot placed asphalt curb shall be placed on a clean area that has previously been coated with an approved bituminous tack coat at a rate as directed by the Engineer. Asphaltic curb shall be placed using an approved asphalt curb spreader which will produce a standard 15 cm curb.

606.04 Method of Measurement

Measurement for payment under this Section shall be the number of linear metres of asphaltic curb acceptably constructed.

606.05 Basis of Payment

Asphaltic concrete curb shall be paid for at the unit bid price per linear metre and this price shall be full compensation for the supply and placement of the curb, all labour, equipment, materials, tools and incidentals necessary to complete the work.

**GENERAL PROVISIONS AND CONTRACT SPECIFICATIONS  
FOR HIGHWAY CONSTRUCTION**

DEPARTMENT OF TRANSPORTATION AND PUBLIC WORKS

---

**ASPHALT CRACK FILLING**

**607**

607.01 Description

This work shall consist of the routing and sealing of random and straight cracks in asphaltic concrete and Portland cement concrete pavement.

607.02 Material

Material used for sealing shall be specifically designed to form resilient adhesive and effective seals for cracks and joints. The material shall fully conform to the requirements of ASTM D-1190 or D-3405 and shall be subject to the Engineer's approval.

Current recommended materials are Hydrotech 6165 or 6160.

607.03 Equipment

Routing equipment shall have self-cleaning vertical routing bits which are capable of producing joints 40 mm in width and 15 mm deep.

The melting kettle shall be a double boiler with indirect heating; using a high flash point oil (Min. 315<sup>0</sup>C) as a heat transfer medium. The kettle shall have an effective mechanically operated agitator and shall be equipped with a positive thermostatic temperature control. The kettle shall be portable, mounted on rubber tires and equipped with a metal shield beneath the fire box to protect the pavement.

607.04 Construction Method

The bags shall be stripped from the compound and the material shall be cut into blocks of approximately 4.5 kg before being placed in the melting kettle. The kettle should be charged by adding a few sections of compound at a time.

The sealing compound shall be melted to the temperature specified by the manufacturer, but any material heated in excess of 230<sup>0</sup> C at any stage of the melting or pouring operation shall not be used in the work. The joint sealing compound shall be poured as soon as possible after the correct pouring temperature is reached. Only as much compound as can be poured in a day in accordance with Provision 106.12 shall be melted.

Cracks shall be routed to a depth of 10 mm and to the width of the crack or 40 mm whichever is less.

Following the routing operation and immediately prior to placing new joint sealing compound, all residual dust and debris created by the routing operation shall be thoroughly cleaned from the cut by a compressed air/hot lance. The Contractor is to sweep the debris to the gutter and dispose of it in accordance with Provision 104.14.

The joints shall be sealed in a neat manner so that upon completion of the work the surface of the sealing material shall be flush with, or not more than 3 mm below the adjacent pavement surface.

The pouring of joints shall only be undertaken when the joint surfaces are dry and the air temperature in the shade is 10<sup>0</sup> C.



**GENERAL PROVISIONS AND CONTRACT SPECIFICATIONS  
FOR HIGHWAY CONSTRUCTION**

DEPARTMENT OF TRANSPORTATION AND PUBLIC WORKS

---

**ASPHALT CRACK FILLING**

**607**

607.05      Method of Measurement

The quantity to be measured for payment under this Section shall be the number of linear metres of cracks filled to the satisfaction of the Engineer.

607.06      Basis of Payment

Payment under this Section shall be at the unit bid price per linear metre and this price shall be full compensation for routing of cracks or joints, supply of crack filling compound, disposal of routed material, placement of crack filling material, all tools, equipment, labour, materials, and incidentals required to perform the work.

**GENERAL PROVISIONS AND CONTRACT SPECIFICATIONS  
FOR HIGHWAY CONSTRUCTION**

DEPARTMENT OF TRANSPORTATION AND PUBLIC WORKS

**COLD MIX BITUMINOUS PATCHING MATERIAL**

**608**

608.01 Description

This Section consists of supplying aggregates and engineered bituminous material to be blended together in a conventional asphalt plant, or approved pugmill, to produce a cold mix bituminous patching material.

608.02 Material

608.02.01 Aggregates

Aggregate to be supplied for the manufacture of cold mix bituminous patching material shall consist of manufactured material derived from crushed stone or gravel, the particles of which shall be clean, hard, durable and free from coatings of silt, clay or other deleterious material.

Aggregate shall meet the physical and gradation requirements of Tables 608-1 and 608-2.

**Table 608-1 Physical Requirements for Aggregate**

Test	Value	ASTM
Magnesium Sulphate Soundness, Max. Loss (%)	12	C-88
Relative Density	2.55 - 2.75	C-128
Absorption, Max. (%)	2	C-128
Moisture, Max. (%)	3	C-566

**Table 608-2 Gradation Requirement for Aggregate**

Sieve Size	Passing (%)	ASTM
12.5 mm	100	C-136
9.5 mm	90-100	C-136
4.75 mm	40-70	C-136
2.36 mm	10-40	C-136
1.18 mm	0-15	C-136
0.300 mm	0-5	C-136
75 µm	0-2	C-117

**GENERAL PROVISIONS AND CONTRACT SPECIFICATIONS  
FOR HIGHWAY CONSTRUCTION**

DEPARTMENT OF TRANSPORTATION AND PUBLIC WORKS

**COLD MIX BITUMINOUS PATCHING MATERIAL**

**608**

608.02.02 Bituminous Materials For Cold Mix

The bituminous material shall be a modified cut-back asphalt containing anti-stripping agents and additives designed to meet the following requirements:

- Stripping resistance
- Flexible and cohesive properties at cold temperatures
- Adhesive quality in wet application
- Long stockpile life of the cold mix bituminous patching material.

The bituminous material shall be in accordance with the requirements of Table 608-3.

Engineered bituminous products not complying with the physical properties specified in Table 608-3 may be approved for use upon review of documentation indicating the material's physical test properties.

**Table 608-3 Requirements for Bituminous Material**

Test	Min.	Max.	ASTM
Kinematic Viscosity at 60° C (mm <sup>2</sup> /s)	250	500	D-2170
Distillation Tests % of Total to 360° C			
to 225°C (%)	0	10	D-402
to 260°C (%)	15	55	D-402
to 315°C (%)	60	87	D-402
Distillation Residue to 360°C, Difference by Volume (%)	67	-	D-402
Water Content (%)	-	0.2	D-95
<b>Tests on Residue</b>			
Penetration at 25°C, 100 g, 5 s (0.1 mm)	120	250	D-5
Ductility at 25°C , 5 cm/min (cm)	100	-	D-113
Solubility in Trichloroethylene by Mass (%)	99	-	D-2042

**GENERAL PROVISIONS AND CONTRACT SPECIFICATIONS  
FOR HIGHWAY CONSTRUCTION**

DEPARTMENT OF TRANSPORTATION AND PUBLIC WORKS

---

**COLD MIX BITUMINOUS PATCHING MATERIAL**

**608**

608.03 Cold Mix Production

Aggregates shall be pre-dried and allowed to cool to a temperature between 60 - 85°C prior to being utilized in the mix, unless otherwise approved by the Engineer.

The aggregate and bitumen shall be mixed to ensure a homogenous mixture with all particles of the mineral aggregate thoroughly coated with bitumen.

The temperature of the final mixture at discharge shall not exceed 70°C.

Cold Mix Production shall occur during daylight hours only.

608.04 Quality Control

Quality control shall be the responsibility of the Contractor. The manufactured cold mix bituminous patching material must meet the following specification requirements.

The extracted bitumen content from the cold mix shall be in accordance with Table 608-4.

**Table 608-4 Minimum Requirements for Extracted Bitumen Content**

Aggregate Absorption (%)		Extracted Bitumen (%)
Min.	Max.	Min.
0.0	1.0	4.5
1.1	1.5	5.0
1.6	2.0	5.5

Extracted bitumen content by ASTM D-2172

The retained coating of bitumen on aggregate must be in excess of 75% when tested in accordance with the following test for stripping resistance:

50 g of the cold mix will be placed in 400 ml of boiling distilled water in a 600 ml glass beaker. It will be stirred with a glass rod at one revolution per second for 3 min.

The percentage coating retained will then be visually evaluated. Retained coatings of less than 75 % shall constitute failure.

The estimated coated area shall be above 95%, as specified in ASTM D-1664.

The cold mix must remain flexible and cohesive to -10°C and must be capable of retaining adhesive qualities in place during wet application.

The cold mix must be capable of remaining pliable and usable in uncovered stockpiles for a minimum of 2 years.

**GENERAL PROVISIONS AND CONTRACT SPECIFICATIONS  
FOR HIGHWAY CONSTRUCTION**

DEPARTMENT OF TRANSPORTATION AND PUBLIC WORKS

---

**COLD MIX BITUMINOUS PATCHING MATERIAL**

**608**

---

608.05 Quality Assurance

At least 1 week prior to proposed production of the cold mix bituminous patching material the Contractor shall:

Notify the Department to:

- Allow scheduling of moisture testing of the aggregate.
- Schedule a Department representative to be at the site at the time of mixing.

Deliver to the Department:

- A sample of the proposed engineered bituminous material.
- Test documentation of the proposed engineered bituminous material indicating compliance with specification requirements.
- Aggregate test documentation indicating compliance with physical and gradation requirements.

The Contractors shall provide to the Department records of testing of the cold mixed bituminous patching material showing compliance.

The cold mixed bituminous patching material shall be randomly sampled by Department representatives at the time of mixing.

608.06 Method of Measurement

Measurement for payment under this Section shall be the number of tonnes of cold mix bituminous patching material acceptably produced.

608.07 Basis of Payment

Cold mix bituminous patching material shall be paid for at the unit bid price per tonne delivered to the stockpile(s) and this price shall be full compensation for all work, material, trucking to the stockpiles, tools, equipment, labour and incidentals necessary to perform the work.

Drying aggregates prior to mixing shall be considered incidental to the work.

**GENERAL PROVISIONS AND CONTRACT SPECIFICATIONS  
FOR HIGHWAY CONSTRUCTION**

DEPARTMENT OF TRANSPORTATION AND PUBLIC WORKS

---

**REHABILITATION**

**700**

- 701 Pulverize in Place
  - 702 Pulverize, Stockpile and Replace RAP
  - 703 Pulverize and Stockpile RAP
  - 704 Cold Plane, Stockpile and Replace RAP
  - 705 Cold Plane Construction Joint
  - 706 Cold Plane and Patch
  - 707 Asphalt Reinforcement Mesh Placement
  - 708 Polystyrene Foam Board Placement
  - 709 Pavement Restoration
  - 710 Cutting Asphalt
  - 711 Excavate and Patch
  - 712 Cold Plane, Stockpile and Replace RAP as Shoulder Material
  - 713 Longitudinal Cold Plane Construction Joint
  - 714 Curb Removal
  - 715 Cold Plane, Transport and Pave
-

**GENERAL PROVISIONS AND CONTRACT SPECIFICATIONS  
FOR HIGHWAY CONSTRUCTION**

DEPARTMENT OF TRANSPORTATION AND PUBLIC WORKS

---

**PULVERIZE IN PLACE**

**701**

701.01      Description

This work shall consist of pulverizing asphaltic concrete, portland cement, soil-cement or combinations thereof in place and utilization of the pulverized material as a base course.

701.02      Construction Method

The Contractor is responsible for determining the depth of pulverization required for the pavement structure.

The Contractor shall cut back shoulder material along the edge of the asphaltic concrete to be pulverized to the depth specified by the Engineer to prevent contamination of the pulverized material. The Contractor will pulverize the existing materials to its full depth using an approved method. After being pulverized, the material shall conform to the gradation specified in Table 701-1.

**Table 701-1      Gradation Requirement for Pulverized Material after Processing**

<b>Sieve Size</b>	<b>Passing (%)</b>
50 mm	100
25 mm	75-100
12.5 mm	55-83
4.75 mm	35-60
1.18 mm	15-45
600 µm	10-35
300 µm	5-25
75 µm	0-10

The pulverized material shall be uniformly graded to the specified lines and grades within a tolerance of 25 mm and thoroughly compacted in accordance with Section 209 to 95% Standard Proctor Density.

Limit shoulder and pulverizing operation to what can be graded daily to allow safe passage of traffic.

When 100 mm or less of new granular material is to be added, it must be thoroughly mixed with the pulverized roadbed. Grading and compaction shall be in accordance with this Section. Maintain the grade and compaction of entire roadbed until the project is complete. The pulverized material may be spread across an area smaller or larger than the original pavement.

**GENERAL PROVISIONS AND CONTRACT SPECIFICATIONS  
FOR HIGHWAY CONSTRUCTION**

DEPARTMENT OF TRANSPORTATION AND PUBLIC WORKS

---

**PULVERIZE IN PLACE**

**701**

701.03      Method of Measurement

Measurement for payment under this Section shall be the number of square metres of pavement pulverized in-place.

New granular material added to the roadbed will be measured for payment as specified in accordance with Section 207.

701.04      Basis of Payment

Payment under this Section shall be at the unit bid price per square metre and this price shall be full compensation for cutting back shoulders, pulverizing, grading, compacting, maintaining the graded base course, tools, labour, equipment, water for compaction and incidentals necessary to carry out the work.

New granular material added will be paid for in accordance with Section 207.



**GENERAL PROVISIONS AND CONTRACT SPECIFICATIONS  
FOR HIGHWAY CONSTRUCTION**

DEPARTMENT OF TRANSPORTATION AND PUBLIC WORKS

---

**PULVERIZE, STOCKPILE AND REPLACE RAP**

**702**

702.01 Description

This work includes pulverizing the existing asphaltic concrete, stockpiling pulverized material and placing the Reclaimed Asphalt Pavement (RAP) on the roadbed as a base material.

702.02 Construction Method

The Contractor shall cut back shoulder material along the edge of the asphaltic concrete to be pulverized to the depth specified by the Engineer to prevent contamination of the RAP.

The Contractor shall break the existing asphaltic concrete to its full depth using an approved method. The Contractor shall prevent soil-cement, sub-base material or other contaminants from mixing with the broken asphaltic concrete.

The Contractor shall limit shoulder and pulverizing operation to what can be graded daily to allow safe passage of traffic.

The Contractor shall provide a suitable stockpile site and submit a proposed site plan and stockpile procedures to the Engineer for review; strip and stockpile the topsoil and overburden. The Contractor shall provide security for the stockpile, which may involve a gate with lock and key, to prevent losses; and ensure the RAP stockpile site meets all safety and environmental regulations. At the completion of the contract, the contractor will reinstate the topsoil and overburden, and be responsible for seeding the area of the stockpile site.

The RAP shall meet the gradation specified in Table 702-1.

**Table 702-1 Gradation Requirement for RAP**

<b>Sieve Size</b>	<b>Passing (%)</b>
50 mm	100
25 mm	75-100
12.5 mm	55-83
4.75 mm	35-60
1.18 mm	15-45
600 µm	10-35
300 µm	5-25
75 µm	0-10

The pulverized material shall be uniformly placed and graded to the specified lines and grades within a tolerance of 25 mm and thoroughly compacted in accordance with Section 209 to 95% Standard Proctor Density.

**GENERAL PROVISIONS AND CONTRACT SPECIFICATIONS  
FOR HIGHWAY CONSTRUCTION**

DEPARTMENT OF TRANSPORTATION AND PUBLIC WORKS

---

**PULVERIZE, STOCKPILE AND REPLACE RAP**

**702**

702.03 Method of Measurement

Measurement for payment under this Section shall be the number of square metres of asphalt actually removed from the road.

702.04 Basis of Payment

Payment under this Section shall be at the unit bid price per square metre and this price shall be full compensation for cutting back shoulders, pulverizing asphaltic concrete, preparing, cleaning, and reinstating stockpile sites, providing the necessary environmental and safety protection, security, transporting RAP, crushing, placing, grading, compacting, maintaining the replaced material, tools, labour, equipment, water for compaction and incidentals necessary to carry out the work.

New granular material added to the roadbed shall be paid for in accordance with Section 207.

**GENERAL PROVISIONS AND CONTRACT SPECIFICATIONS  
FOR HIGHWAY CONSTRUCTION**

DEPARTMENT OF TRANSPORTATION AND PUBLIC WORKS

---

**PULVERIZE AND STOCKPILE RAP**

**703**

703.01 Description

This work includes pulverizing the existing asphalt concrete, transporting the Reclaimed Asphalt Pavement (RAP) and constructing a RAP stockpile.

703.02 Construction Method

The Contractor shall cut back shoulder material along the edge of the asphalt concrete to be pulverized to the depth specified by the Engineer in order to prevent contamination of the RAP.

The Contractor shall break the existing asphaltic concrete to its full depth using an approved method. The Contractor shall prevent soil-cement, sub-base material or other contaminants from mixing with the broken asphaltic concrete.

The size of the RAP shall not be greater than the maximum size that can be efficiently loaded into trucks.

The RAP shall be transported to a designated site and the RAP shall be crushed by an approved method so that all material will pass a 50 mm Sieve. The crushed RAP shall be placed in a stockpile in such a manner that it does not become contaminated with other material.

The Contractor shall provide security for the RAP stockpile, which may include a gate with lock and key, to prevent losses.

After the broken asphalt concrete has been removed, the roadbed shall be graded to provide safe passage for traffic. The shoulder and pulverizing operation shall be limited to what can be graded daily to allow safe passage of traffic during non-working hours in accordance with Section 105.06.

703.03 Method of Measurement

Measurement for payment under this Section shall be the number of square metres of road actually pulverized and stockpiled.

703.04 Basis of Payment

Payment under this Section shall be at the unit bid price per square metre and this price shall be full compensation for cutting back shoulders, breaking asphaltic concrete, RAP transportation to stockpile site, providing for the necessary environmental and safety protection, security, RAP crushing, construction of RAP stockpiles, all tools, material, equipment and incidentals necessary to carry out the work.

**GENERAL PROVISIONS AND CONTRACT SPECIFICATIONS  
FOR HIGHWAY CONSTRUCTION**

DEPARTMENT OF TRANSPORTATION AND PUBLIC WORKS

---

**COLD PLANE, STOCKPILE AND REPLACE RAP**

**704**

704.01 Description

This work includes the cold planing, removal and stockpiling of asphaltic concrete from the roadway, and placement of the Reclaimed Asphalt Pavement (RAP) on the roadbed.

704.02 Construction Method

The cold planer shall be a self-propelled commercially designed unit, equipped with automatic longitudinal and transverse grade and slope controls. Minimum planing width capability shall be 2 m. All RAP material shall pass a 50 mm Sieve.

The cold planer shall be further equipped with a loading conveyor to facilitate the removal and transportation of the RAP directly by truck. Depositing of the RAP directly on the roadway shall not be permitted.

The longitudinal and transverse grade and slope controls shall be equipped to operate from a ski or matching shoe and capable of maintaining a profile grade elevation or cross slope.

The contractor will reshape or remove any material required to establish proper drainage at the end of each days milling production.

With full depth removal, care shall be taken in the removal of the asphaltic concrete not to contaminate the RAP with the underlying base material. If the Contractor removes the specified thickness in more than one layer, then material from each layer must be stockpiled separately as directed by the Engineer. For partial depth removal, the loose material remaining after removal of the RAP shall be cleaned from the surface prior to opening to traffic.

The contractor shall provide a suitable stockpile site and submit a proposed site plan and stockpile procedures to the Engineer for review. The contractor shall strip and stockpile the topsoil and overburden in accordance with Section 204; and provide security for the stockpile, which may involve a gate with a lock and key, to prevent losses. At the completion of the contract, the contractor will reinstate the topsoil and overburden and be responsible for seeding the area located at the stockpile site.

Proper stockpiling procedures shall be followed in constructing RAP stockpiles. Stockpiles shall be built up in 1 m deep layers. RAP placed in stockpiles by trucks shall be uniformly stop-dumped to prevent segregation. The use of heavy equipment in constructing the stockpiles shall be such to prevent compaction of the RAP. The Contractor must ensure stockpile site meets all safety and environmental regulations.

Stockpiles shall be placed on a level well drained base capable of supporting the entire weight of the stockpile and in such a manner to ensure maximum recovery of the RAP without contamination.

The RAP shall be uniformly placed and graded to the specified lines and grades within a tolerance of 25 mm and thoroughly compacted in accordance with Section 209 to 95% Standard Proctor Density.

When 100 mm or less of new granular material is to be added, it must be thoroughly mixed with the RAP.

**GENERAL PROVISIONS AND CONTRACT SPECIFICATIONS  
FOR HIGHWAY CONSTRUCTION**

DEPARTMENT OF TRANSPORTATION AND PUBLIC WORKS

---

**COLD PLANE, STOCKPILE AND REPLACE RAP**

**704**

---

704.03 Method of Measurement

Measurement for payment under this Section shall be the number of square metres of asphaltic concrete cold planed.

704.04 Basis of Payment

Cold planing of asphaltic concrete, shall be paid for at the unit bid price per square metre and this price shall be full compensation for cold planing, preparing the site for stockpiling and reinstating, security, construction of Rap stockpile, providing environmental and safety protection necessary, transporting, placing, mixing, and compacting cold planed Rap, equipment, tools, labour and incidentals necessary to compete the work.

New granular material added to the road bed shall be paid for in accordance with Section 207.

**GENERAL PROVISIONS AND CONTRACT SPECIFICATIONS  
FOR HIGHWAY CONSTRUCTION**

DEPARTMENT OF TRANSPORTATION AND PUBLIC WORKS

---

**COLD PLANE CONSTRUCTION JOINT**

**705**

---

705.01 Description

Work under this Section includes cold planing existing asphalt concrete across the width of the road at the beginning and end of the Contract limits. The purpose of this work is to allow the proper grade transition with the existing pavements.

The depth to cold plane shall be determined by the new overlay thickness. Cold planed material will be removed and placed as directed.

705.02 Construction Method

The Contractor shall cold plane the existing asphaltic concrete surface to satisfy the paving requirements for transverse construction joints as detailed in Sub-Provision 603.13.03.

All areas which have been cold planed shall be swept and tacked.

Subject to Section 104.14, the Rap material resulting from this work shall be deemed surplus or waste by the Engineer.

705.03 Method of Measurement

The quantity to be measured under this Section shall be the number of square metres of pavement which have been cold planed and tacked.

705.04 Basis of Payment

Payment under this Section shall be at the unit bid price per square metre and this price shall be full compensation for all work, tools, equipment, disposal of waste material, labour, tack and incidentals necessary to complete the work.

**GENERAL PROVISIONS AND CONTRACT SPECIFICATIONS  
FOR HIGHWAY CONSTRUCTION**

DEPARTMENT OF TRANSPORTATION AND PUBLIC WORKS

---

**COLD PLANE AND PATCH**

**706**

---

706.01      Description

This work shall consist of cold planing designated areas to a depth determined by the Engineer, and patching with hot mix asphaltic concrete.

706.02      Construction Method

The Contractor shall cold plane areas to be patched to a depth determined by the Engineer.

The cold planed edges are to be vertical and the area shall be broomed clean prior to tack coat application.

The areas shall be patched with an approved asphaltic concrete mix determined by the Engineer. The asphaltic concrete production and placement shall be in accordance to Section 603.

Work shall be scheduled so that at the end of each day all patches are flush with the adjacent pavement and so that no planed areas are left open.

Subject to Section 104.14, the Rap material resulting from this work shall be deemed surplus or waste by the Engineer.

706.03      Method of Measurement

The quantity to be measured under this Section shall be the number of square metres of patch completed. If the Contractor is required to cold plane to a depth greater than 50 mm, as designated by the Engineer, then the additional depth beyond 50 mm shall also be measured for payment under this section.

706.04      Basis of Payment

Payment for this work shall be at the unit bid price per square metre and this price shall be adjusted for cold planing depths greater than 50 mm according to the following formula:

$$\frac{(50 \text{ mm} + \text{Additional Depth in mm}) \times \text{Unit Bid Price}}{50 \text{ mm}}$$

The unit price bid shall be full compensation for planing, preparation and cleaning, supply and placement of tack coat material, supply and placement of asphaltic concrete, compaction, and all equipment, tools, labour, and incidentals necessary to complete the work.

**GENERAL PROVISIONS AND CONTRACT SPECIFICATIONS  
FOR HIGHWAY CONSTRUCTION**

DEPARTMENT OF TRANSPORTATION AND PUBLIC WORKS

---

**ASPHALT REINFORCEMENT MESH PLACEMENT**

**707**

707.01 Description

This item relates to the strengthening of cracks or joints to be treated.

The Engineer shall designate the cracks or joints to be treated.

All relevant sections of Division 600 shall be in effect.

707.02 Material

The road reinforcement mesh must be self adhesive type made of glass fibre strand: GLASGRID 8502<sup>(R)</sup> or equivalent in terms of tensile strength, area weight, elongation, melt point and bond.

Asphaltic concrete for patching shall be Class C or Class B in accordance with Section 603.

Tack coat shall be in accordance with Section 601.

707.03 Coordination with Other Work

Successful completion of this work requires coordination with the asphaltic concrete levelling course placement. The timing and order of individual tasks may be affected.

707.04 Construction Method

A sectional view shall be shown on the Drawings that illustrates the location of the reinforcement in the pavement.

- (1) Transverse Cracks and Longitudinal Cracks
  - a) The crack shall be cold planed to a width of 500 mm and to a depth of 50 mm. All planed asphaltic concrete shall be reclaimed and spread on a designated road.
  - b) The planed area shall be thoroughly cleaned in preparation for patching.
  - c) Tack coat shall be applied to the planed area.
  - d) The planed area shall be repaved full depth and width with asphaltic concrete Class C or Class B. Patch smoothness is important to ensure a successful bond with the reinforcement mesh.
  - e) Immediately prior to placement of the levelling course, the Contractor shall supply and install the reinforcement mesh over the patches according to the manufacturer's instructions. Unless otherwise directed by the Engineer, the Contractor shall arrange to have a manufacturer's representative on site to provide technical support and assistance to the work crews on the first day of application.
  - f) Reinforcement mesh shall be bonded to the pavement by rolling in place with a pneumatic roller weighing no less than ten (10) tonnes.



**GENERAL PROVISIONS AND CONTRACT SPECIFICATIONS  
FOR HIGHWAY CONSTRUCTION**

DEPARTMENT OF TRANSPORTATION AND PUBLIC WORKS

---

**ASPHALT REINFORCEMENT MESH PLACEMENT**

**707**

- g) A second course of reinforcement mesh may be placed, as directed by the Engineer, between subsequent layers of asphaltic concrete at the crack location.
- (2) Longitudinal Joints
  - a) Tack Coat shall be applied to the longitudinal joint.
  - b) Immediately prior to placement of the levelling course, the Contractor shall supply and install the reinforcement mesh over the joint according to the manufacturer's instructions. Unless otherwise directed by the Engineer, the Contractor shall arrange to have a manufacturer's representative on site to provide technical support and assistance to the work crews on the first day of application.
  - c) Reinforcement mesh shall be bonded to the pavement by rolling in place with a pneumatic roller weighing no less than ten (10) tonnes.
  - d) A second course of reinforcement mesh may be placed, as directed by the Engineer, between subsequent layers of asphaltic concrete at the joint location.

707.05 Method of Measurement

The quantities to be measured for payment under this Section shall be the number of square metres of reinforcement mesh acceptably placed.

707.06 Basis of Payment

Reinforcement mesh shall be paid at the unit bid price per square metre and this price shall be full compensation for preparing the pavement surface, supplying, placing and rolling the mesh.

Cold planing and patching shall be paid for in accordance with Section 706.

**GENERAL PROVISIONS AND CONTRACT SPECIFICATIONS  
FOR HIGHWAY CONSTRUCTION**

DEPARTMENT OF TRANSPORTATION AND PUBLIC WORKS

---

**POLYSTYRENE FOAM BOARD PLACEMENT**

**708**

708.01 Description

This Section applies to the supply and placement of polystyrene foam boards (600 mm x 2.4 m) for the purpose of roadbed insulation.

The material shall be polystyrene foam board (600 mm x 2.4 m) having a compressive strength rating equal to or greater than 415 kPa and meeting or exceeding CGSB 51.20-M87, Type IV.

708.02 Construction Method

The foam boards shall be placed as shown in the contract drawings and plans. For the most part, the boards shall be placed directly on the existing paved surface except for a nominal 600 mm extension beyond the edge of the existing paved shoulder; and except for the transition zones at either end of the job, in which case the foam boards shall be placed on grade as shown in the detailed contract Drawings.

The foam boards shall be placed in areas designated in the Contract, lengthwise and parallel to the centreline of the roadway to obtain tight butt joints and staggered transverse joints. The boards should be secured during the backfilling process by placing small piles of the specified granular material on the boards immediately after installation.

Placement of granular base shall be in accordance with Section 207, except that when placed over the polystyrene foam boards; it shall be placed in 1 lift by end dumping and spreading.

Traffic shall not be permitted on the polystyrene foam board sections until the full depth of the granular base course has been placed and compacted in accordance with Section 207.

At the end of each working day, the polystyrene foam board placement shall have progressed to the same station on both sides of the centreline and a minimum 10 m temporary ramp of granular material shall be constructed to provide traffic a smooth transition between existing and granular base grades. When placement resumes, care shall be taken during the removal of the temporary ramps to ensure that the foam boards are not damaged and that a true edge is exposed and available to join on to.

708.03 Method of Measurement

Measurement for payment under this Section shall be the number of square metres of road surface covered with polystyrene foam boards based on board count for the various thicknesses used.

708.04 Basis of Payment

Payment under this Section shall be at the unit bid price per square metre and this price shall be full compensation for all of the work and for all labour, equipment, materials, polystyrene foam boards and incidentals necessary to complete the work.

**GENERAL PROVISIONS AND CONTRACT SPECIFICATIONS  
FOR HIGHWAY CONSTRUCTION**

DEPARTMENT OF TRANSPORTATION AND PUBLIC WORKS

---

**PAVEMENT RESTORATION**

**709**

709.01 Description

The work carried out under this Section shall include the restoration of pavement surfaces cut or damaged during the course of other work.

709.02 Construction Method

The Contractor shall excavate, level and clear the area to be restored to a depth of 150 mm if the adjacent pavement is asphaltic concrete combined with soil-cement stabilization or to the subgrade if the adjacent pavement consists of full depth asphaltic concrete or asphaltic concrete combined with a granular base course.

Each layer shall be compacted, in accordance with Section 209, to 95% Standard Proctor Density except the top 150 mm which shall be compacted to 100% Standard Proctor Density.

Where the adjacent pavement includes a granular base course, the Contractor shall place equivalent granular material by hand in the area to be restored in layers not exceeding 150 mm and shall compact each layer, in accordance with Section 209 to 95% Standard Proctor Density. The granular material shall be placed to the top of the granular base course in the adjacent pavement.

The Contractor shall clean and apply tack coat to the edges of adjacent pavement.

The Contractor shall place hot mix base course asphaltic concrete, Class "A", approved by the Engineer, by hand in uniform layers not exceeding 75 mm in thickness in accordance with Section 603. Sub-section 603.14 General Requirements for Compaction shall not apply to asphalt placed under this Section.

The Contractor shall place a layer of hot mix seal course asphaltic concrete, Class "C", on top of the base course asphalt in layers not exceeding 50 mm and shall compact it in accordance with Section 603. Sub-section 603.14 General Requirements for Compaction shall not apply to asphalt placed under this Section.

709.03 Method of Measurement

The quantity to be paid for under this Section shall be the number of square metres of pavement restored as authorized by the Engineer.

No measurement shall be made for granular base course material, tack coat or hot mix asphaltic concrete placed under this Section.

No measurement for payment shall be made under this Section for pavement restoration required as a result of the Contractor's negligence in performing any components of the work.

709.04 Basis of Payment

Pavement restoration shall be paid for at the unit bid price per square metre and this price shall be full compensation for excavation, supply and placement of granular base course material, supply and placement of tack coat material, supply and placement of hot mix asphaltic concrete, compaction, warranty of the work, equipment, tools, labour and incidentals necessary to complete the work.

**GENERAL PROVISIONS AND CONTRACT SPECIFICATIONS  
FOR HIGHWAY CONSTRUCTION**

DEPARTMENT OF TRANSPORTATION AND PUBLIC WORKS

---

**CUTTING ASPHALT**

**710**

710.01

Description

This work shall consist of cutting pavement in neat and straight lines or as directed by the Engineer.

710.02

Construction Method

The Contractor shall cut to the full depth of pavement, using a saw or jackhammer, the lines on the pavement surface as designated by the Engineer. The Contractor shall ensure that all such cuts are neat, straight, vertical and that pavement to be left in place is not damaged.

710.03

Method of Measurement

Measurement for payment under this Section shall only apply to pavement cut with the Engineer's approval.

The quantity to be measured under this Section shall be the number of linear metres of pavement cut to full depth. If the depth of cut is greater than 100 mm than the additional depth beyond 100 mm shall also be measured for payment under this Section.

710.04

Basis of Payment

Payment under this Section shall be at the unit bid price per linear metre of cut pavement and this price shall be adjusted for cuts greater than 100 mm according to the following formula:

$$\frac{100 \text{ mm} + \text{Additional Thickness} \times \text{Unit Bid Price}}{100 \text{ mm}}$$

The unit bid price shall be full compensation for equipment, tools, labour and incidentals necessary to complete the work.

**GENERAL PROVISIONS AND CONTRACT SPECIFICATIONS  
FOR HIGHWAY CONSTRUCTION**

DEPARTMENT OF TRANSPORTATION AND PUBLIC WORKS

---

**EXCAVATE AND PATCH**

**711**

---

711.01

Description

This work shall consist of the restoration of the pavement to the lines as directed by the Engineer.

711.02

Construction Method

The Contractor shall cut to the full depth of the pavement, excavate and level.

The Contractor shall clean and apply tack coat to the edges of the adjacent pavement.

The Contractor shall place an approved asphaltic concrete mix determined by the Engineer in the excavated area in accordance with Section 603.

Subject to Section 104.14, the Rap material resulting from this work shall be deemed surplus or waste by the Engineer.

711.03

Method of Payment

The quantity to be paid for under this Section shall be the number of square metres of pavement excavated and patched.

711.04

Basis of Payment

The number of square metres of pavement excavated and patched shall be paid for at the unit bid price per square metre and this price shall be full compensation for excavation, supply and placement of tack coat material, supply and placement of asphaltic concrete, compaction, and all equipment, tools, labour and incidentals necessary to complete the work.

**GENERAL PROVISIONS AND CONTRACT SPECIFICATIONS  
FOR HIGHWAY CONSTRUCTION**

DEPARTMENT OF TRANSPORTATION AND PUBLIC WORKS

---

**COLD PLANE, STOCKPILE AND REPLACE RAP AS SHOULDER MATERIAL**

**712**

712.01 Description

This work includes the cold planing, removal and stockpiling of asphaltic concrete from the roadway, and placement of the Reclaimed Asphalt Pavement (RAP) as shoulder material.

712.02 Construction Method

The cold planer shall be a self-propelled commercially designed unit, equipped with automatic longitudinal and transverse grade and slope controls. Minimum planing width capability shall be 2 m. All RAP material shall pass a 50 mm Sieve.

The cold planer shall be further equipped with a loading conveyor to facilitate the removal and transportation of the RAP directly by truck. Depositing of the RAP directly on the roadway shall not be permitted.

The contractor will reshape or remove any material required to establish proper drainage at the end of each days milling production.

The longitudinal and transverse grade and slope controls shall be equipped to operate from a ski or matching shoe and capable of maintaining a profile grade elevation or cross slope.

With full depth removal, care shall be taken in the removal of the asphaltic concrete not to contaminate the RAP with the underlying base material. If the Contractor removes the specified thickness in more than one layer, then material from each layer must be stockpiled separately as directed by the Engineer. For partial depth removal, the loose material remaining after removal of the RAP shall be cleaned from the surface prior to opening to traffic.

The contractor shall provide a suitable stockpile site and submit a proposed site plan and stockpile procedures to the Engineer for review. The contractor shall strip and stockpile the topsoil and overburden in accordance with Section 204; and provide security for the stockpile, which may involve a gate with a lock and key, to prevent losses. At the completion of the contract, the contractor will reinstate the topsoil and overburden and be responsible for seeding the area located at the stockpile site.

Proper stockpiling procedures shall be followed in constructing RAP stockpiles. Stockpiles shall be built up in 1 m deep layers. RAP placed in stockpiles by trucks shall be uniformly stop-dumped to prevent segregation. The use of heavy equipment in constructing the stockpiles shall be such to prevent compaction of the RAP. The Contractor must ensure the stockpile site meets all safety and environmental regulations.

The Stockpiles shall be placed on a level well drained base capable of supporting the entire weight of the stockpile and in such a manner to ensure maximum recovery of the RAP without contamination.

The Contractor should provide security for the stockpile, which may include a gate with lock and key, to prevent losses.

The Contractor shall prepare the shoulder, as provided for elsewhere in the contract, and shall ensure that any debris has been removed from the shoulder.

**GENERAL PROVISIONS AND CONTRACT SPECIFICATIONS  
FOR HIGHWAY CONSTRUCTION**

DEPARTMENT OF TRANSPORTATION AND PUBLIC WORKS

---

**COLD PLANE, STOCKPILE AND REPLACE RAP AS SHOULDER MATERIAL**

**712**

The RAP material shall be placed by a shouldering machine previously approved by the Engineer.

The Contractor shall produce a final graded surface having a uniform 4% cross-slope towards the ditch except on the outer edge of a super-elevated curve where the Contractor shall consult with the Engineer for direction.

Where shoulder material is to be placed after paving, compaction of aggregate shall be achieved by using an appropriate rubber-tired roller, in accordance with Section 209, to 95% of the Standard Proctor Density. The Engineer may approve the use of an alternative type of roller if safe operation of a rubber-tired roller cannot be achieved. Excess shoulder material shall be removed at the Contractor's own expense.

712.03 Method of Measurement

Measurement for payment under this Section shall be the number of square metres of asphaltic concrete cold planed.

712.04 Basis of Payment

Cold planing of asphaltic concrete, shall be paid for at the unit bid price per square metre and this price shall be full compensation for cold planing, preparing the site for stockpiling, reinstatement of stockpile site, security of stockpiled material, providing environmental and safety protection necessary, placing cold planed RAP, equipment, tools, labour and incidentals necessary to complete the work.

**GENERAL PROVISIONS AND CONTRACT SPECIFICATIONS  
FOR HIGHWAY CONSTRUCTION**

DEPARTMENT OF TRANSPORTATION AND PUBLIC WORKS

---

**LONGITUDINAL COLD PLANE CONSTRUCTION JOINT**

**713**

713.01 Description

Work under this Section includes cold planing along the longitudinal edge of the existing asphalt. The purpose of this work is to add additional width of asphalt to the existing structure, in multiple lifts of varying thickness, as directed by the Engineer.

The depth and width to cold plane will be determined by the Engineer. Cold planed material will be removed and placed as directed. The longitudinal cold planing will correspond with the placement of the individual lifts of asphalt. As directed by the Engineer, the cold planing may be required to be completed over a period of days due to safety concerns for the travelling public.

713.02 Construction Method

The Contractor will cold plane the existing asphaltic concrete surface to satisfy the paving requirements for longitudinal construction joints as detailed in Sub-Provision 603.13.01.

All areas which have been cold planed will be swept.

The RAP material resulting from this work may be used in other work as directed by the Engineer, or otherwise disposed of by the Contractor.

713.03 Method of Measurement

The quantity to be measured under this Section will be the number of square metres of pavement which has been cold planed.

713.04 Basis of Payment

Payment under this Section shall be at the unit bid price per square metre and this price shall be full compensation for all work, tools, equipment, labour and incidentals necessary to complete the work. No additional payments will be authorized for float charges if the cold planer is removed and returned to site.



**GENERAL PROVISIONS AND CONTRACT SPECIFICATIONS  
FOR HIGHWAY CONSTRUCTION**

DEPARTMENT OF TRANSPORTATION AND PUBLIC WORKS

---

**CURB REMOVAL**

**714**

---

714.01 Description

This work includes the removal & disposal of the existing concrete curb or asphaltic concrete curb and the adjacent material.

714.02 Construction Methods

The Contractor shall remove the existing curb along with the adjacent material to a maximum of 0.5 metres behind the existing curb. The work will include loading the curb, adjacent material and disposing of the material; sweeping and cleaning of the area as required.

714.03 Method of Measurement

Measurement of payment under this section shall be the number of linear meters of curb removed.

714.04 Basic of Payment

Payment under this section shall be at the unit bid price per linear meter and this price shall be full compensation for removing and disposing of the curb and adjacent material, sweeping, general clean up, tools, labour, equipment, and incidentals necessary to carry out the work.

**GENERAL PROVISIONS AND CONTRACT SPECIFICATIONS  
FOR HIGHWAY CONSTRUCTION**

DEPARTMENT OF TRANSPORTATION AND PUBLIC WORKS

---

**COLD PLANE, TRANSPORT AND PAVE**

**715**

---

715.01 Description

This work includes the cold planing, removal and transporting of asphaltic concrete from the roadway, and placement of the Reclaimed Asphalt Pavement (RAP) on a roadbed as a paving operation.

715.02 Construction Method

The cold planer shall be a self-propelled commercially designed unit, equipped with automatic longitudinal and transverse grade and slope controls. The longitudinal and transverse grade and slope controls shall be equipped to operate from a ski or matching shoe and capable of maintaining a profile grade elevation and cross slope. The cold planer shall have a minimum planing width capability of 2 m. All RAP material shall pass a 50 mm sieve.

The cold planer shall be further equipped with a loading conveyor to facilitate the removal and transportation of the RAP directly by truck. The contractor will deliver the RAP directly to an alternate site, directed by the Engineer, and place with an approved asphalt spreader and compaction equipment in accordance with Section 603.05.

With full depth removal, care shall be taken in the removal of the asphaltic concrete not to contaminate the RAP with the underlying base material. If the Contractor removes the specified thickness in more than one layer, then material from each layer must be placed as directed by the Engineer. For partial depth removal, the loose material remaining after removal of the RAP shall be cleaned from the surface prior to opening to traffic.

The length of haul from the cold planing operation to the placement operation will be specified by the Engineer. The Rap shall meet the gradation specified in Table 715-1.

Table 715-1 Gradation Requirement for RAP

Sieve Size	Passing (%)
50 mm	100
25 mm	75-100
12.5 mm	55-83
4.75 mm	35-60
1.18 mm	15-45
600 µm	10-35
300 µm	5-25
75 µm	0-10

**GENERAL PROVISIONS AND CONTRACT SPECIFICATIONS  
FOR HIGHWAY CONSTRUCTION**

DEPARTMENT OF TRANSPORTATION AND PUBLIC WORKS

---

**COLD PLANE, TRANSPORT AND PAVE**

**715**

---

715.03 Method of Measurement

Measurement for payment under this Section shall be the number of square metres of asphaltic concrete cold planed.

715.04 Basis of Payment

The cold planing of asphaltic concrete, shall be paid for at the unit bid price per square metre and this price shall be full compensation for cold planing, transporting, placing cold planed RAP, compacting, equipment, tools, labour, and incidentals necessary to complete the work.

**GENERAL PROVISIONS AND CONTRACT SPECIFICATIONS  
FOR HIGHWAY CONSTRUCTION**

DEPARTMENT OF TRANSPORTATION AND PUBLIC WORKS

---

**ENVIRONMENT**

**800**

- 801 Check Dams
  - 802 Water for Dust Control
  - 803 Hydro Seeding
  - 804 Seeding
  - 805 Mulching
  - 806 Silt Fence
  - 807 Erosion Control Mats
  - 808 Sediment Trap
  - 809 Sodding
  - 810 Maintenance and Decommissioning of Sediment Control Structures
  - 812 Compost
  - 813 Gabions
-

**GENERAL PROVISIONS AND CONTRACT SPECIFICATIONS  
FOR HIGHWAY CONSTRUCTION**

DEPARTMENT OF TRANSPORTATION AND PUBLIC WORKS

---

**CHECK DAMS**

**801**

---

801.01 Description

This work shall consist of the in-place construction of rip rap or straw bale check dams or flow checks. They shall be constructed across roadside drainage ditches and throughout cut sections to trap sediment and to prevent erosion of a small gully or ditch bottom and to trap sediment by reducing velocity and concentration.

801.02 Material and Construction Method - General

All materials are to be supplied by the Contractor. Geotechnical fabric shall be in accordance with the requirements of Section 218. Random rip rap shall be supplied in accordance with the requirements of Section 213. Check dams are to be installed during construction and after the ditches are brought to final grade.

Check dams are to be constructed along any new ditching of the highway at spacings determined in sensitive areas by dividing 61 metres by the ditch grade in percent. This spacing provides for the placement of the check dams so that the crest of the downstream structure is at the same elevation as the toe of the upstream structure. Spacing may be increased where site conditions warrant, for example, in long stretches where the ditches are very flat. In these instances, the maximum spacing shall not exceed 500 metres.

801.03 Maintenance

The Contractor shall maintain check dams in a functional condition until the grass on seeded slopes and ditch bottom is sufficiently established to be an effective deterrent to erosion. This includes inspections after each rainfall, immediate repairs to structures found not functioning properly and removal of sediment deposits.

The Contractor shall dispose of the sediment deposits at a location at least 30 m away from a watercourse, and in such a manner that the sediment will not be returned to the work area or watercourse.

The Contractor shall remove the sediment deposits prior to the level of sedimentation reaching a point within 100 mm of the crest of the notch.

The Engineer may require that some or all check dams be maintained after substantial completion of the work.

801.04 Decommissioning

\_\_\_\_\_ The Contractor shall remove the check dams after the site has been stabilized and level and seed the areas that are disturbed during the removal.

**GENERAL PROVISIONS AND CONTRACT SPECIFICATIONS  
FOR HIGHWAY CONSTRUCTION**

DEPARTMENT OF TRANSPORTATION AND PUBLIC WORKS

---

**CHECK DAMS**

**801**

---

801.05 Rip Rap Check Dam

Check dams in this section are to be installed as indicated on Figures 801-01 and 801-02.

Rip Rap check dams are to be used in ditches where the ditch slope is greater than 2 (%) two percent.

The Contractor shall comply with the following procedure:

Excavate a sediment pit just upstream of where the check dam is to be constructed.

Key the check dam 150 mm into the slopes and ditch surface to prevent undermining. Place geotechnical fabric on the prepared area starting at the toe of slope of the sediment pit and overlap edges by 100 mm. Roll out the fabric in the direction of flow and extend underneath the apron. Note that the aprons in these structures are not keyed into the soil.

Place riprap for the check dam and apron on the fabric being careful not to cause any damage.

Make the top of the check dam at least 300 mm wide. The crest of the spillway on the dam is to be located 300 mm below the elevation at the ends of the dam to ensure flow over the spillway and to avoid overtopping at the edges where erosion may occur. The height of the spillway shall be a minimum of 300 mm.

801.06 Straw Bale Check Dams

Straw bale check dams are more suitable for treating runoff from small drainage areas or where ditches have relatively flat gradients, equal to or less than 2 (%) two percent, and have low velocities. Straw bale check dams shall be comprised of a minimum of 5 bales, with additional bales installed as required.

Check dams in this section are to be installed as indicated on Figures 801-03 and 801-04. The Contractor shall comply with the following procedure:

Remove rocks, roots, logs and other debris and grade as required.

Prepare 100 mm deep trench along entire footprint of check dam. Embed straw bales in trench and place the bales tightly together. Drive two sturdy wooden stakes through each bale, deep enough to anchor them securely. Drive the stakes in each bale toward the previously laid bale to force the bales together.

Wedge loose straw between any cracks or openings, the subsequent movement of the loose straw tends to seal any undetected openings in the barrier.

On both sides of the check dam, the bales shall extend up the ditch side slope to ensure flow over the spillway and to avoid overtopping at the edges of the check dam where erosion may occur. The crest of the spillway on the dam is to be located a minimum of 300 mm below the elevation where the upper most bale and the ditch intersect.

A sediment collection pit shall be excavated upstream of the check dam.

**GENERAL PROVISIONS AND CONTRACT SPECIFICATIONS  
FOR HIGHWAY CONSTRUCTION**

DEPARTMENT OF TRANSPORTATION AND PUBLIC WORKS

---

**CHECK DAMS**

**801**

---

801.07 Method of Measurement

The quantity to be measured for payment shall be the number of check dams that are constructed and maintained as per this specification.

801.08 Basis of Payment

Payment for work under this item shall be a unit price for each type of check dam and shall be full compensation for all labour, equipment and material to install, maintain and decommission the checkdams including the disposal of all surplus materials and accumulated sediments, and site reinstatement to a condition acceptable to the Engineer.

Maintenance and decommissioning that is required after substantial completion of the site work shall be paid for under Section 810.

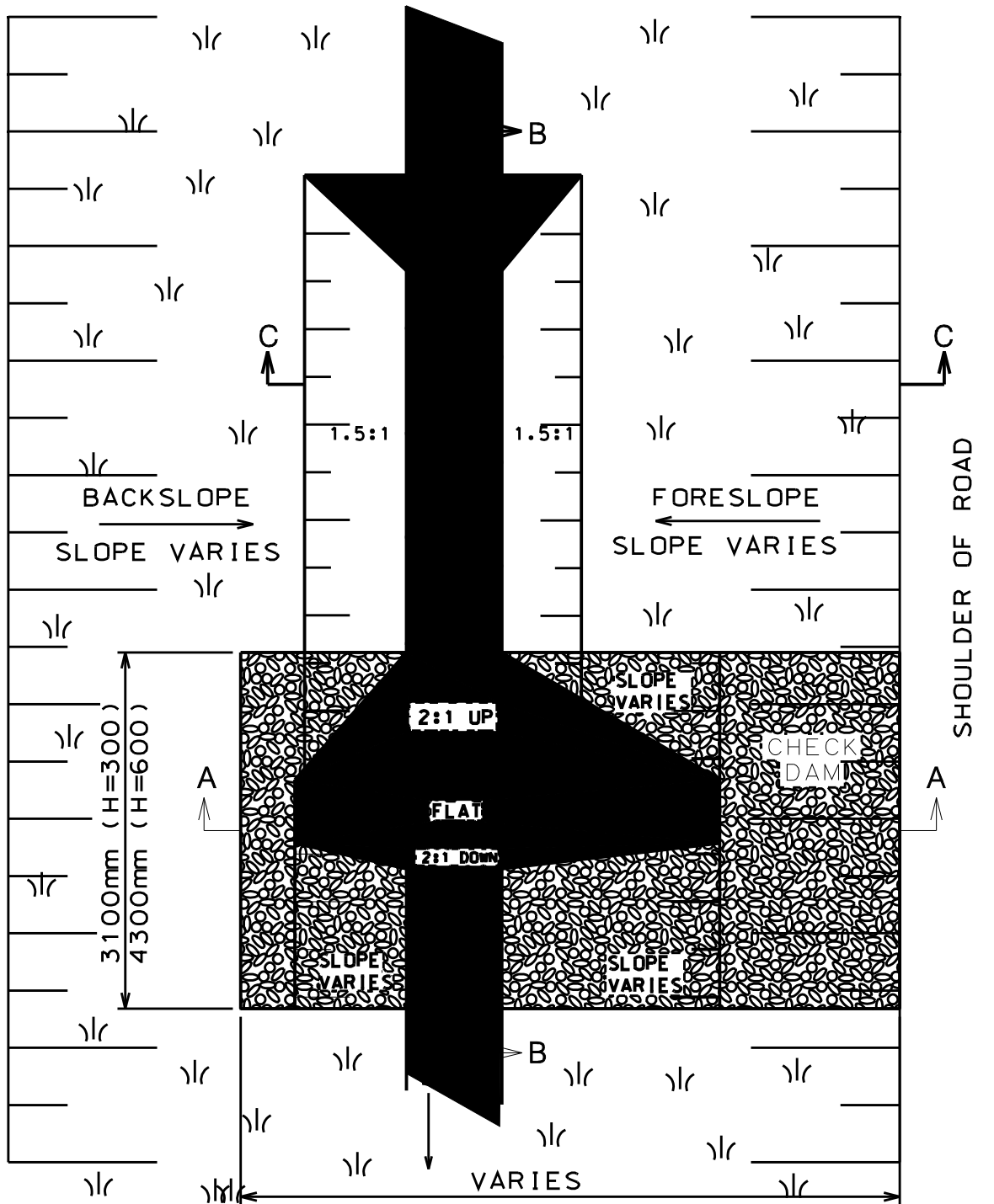

PLAN VIEW (N.T.S.)

Notes:

1. Depth, width and side slopes of sediment pit may vary with soil conditions (as directed by engineer)
2. All riprap shown is R-5
3. See Figure 801-02 for section details.

**FIGURE 801-01 RIP RAP CHECK DAM**  
 REVISED 2002



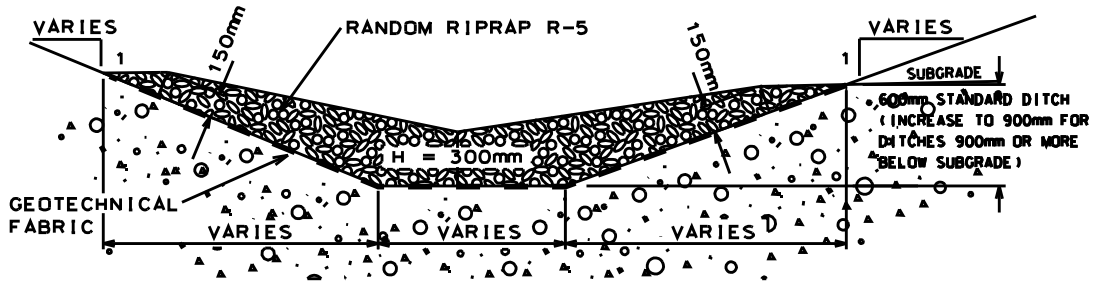

Note: H = 300mm for standard ditch of 600mm below subgrade  
 H = 600mm for ditches 900mm or more below subgrade

SECTION A-A (N.T.S.)

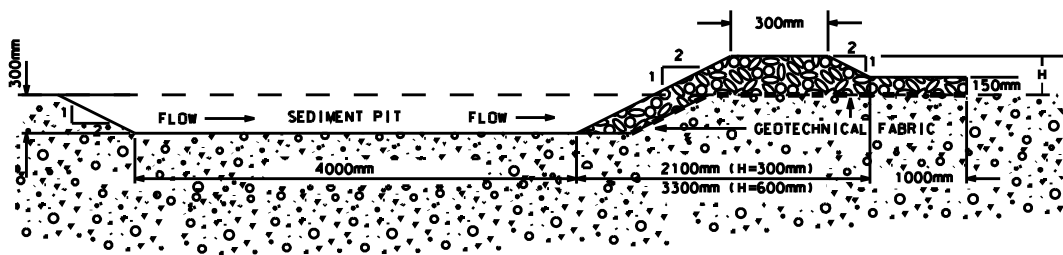

SECTION B-B (N.T.S.)

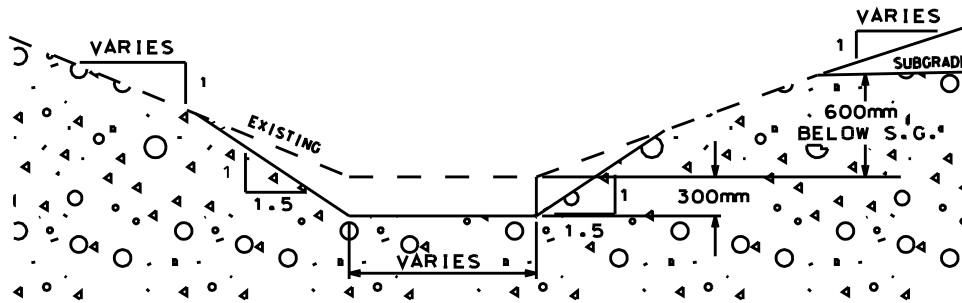

SECTION C-C (N.T.S.)

**FIGURE 801-02 SECTION DETAILS FOR RIP RAP CHECK DAM**  
 REVISED 2002

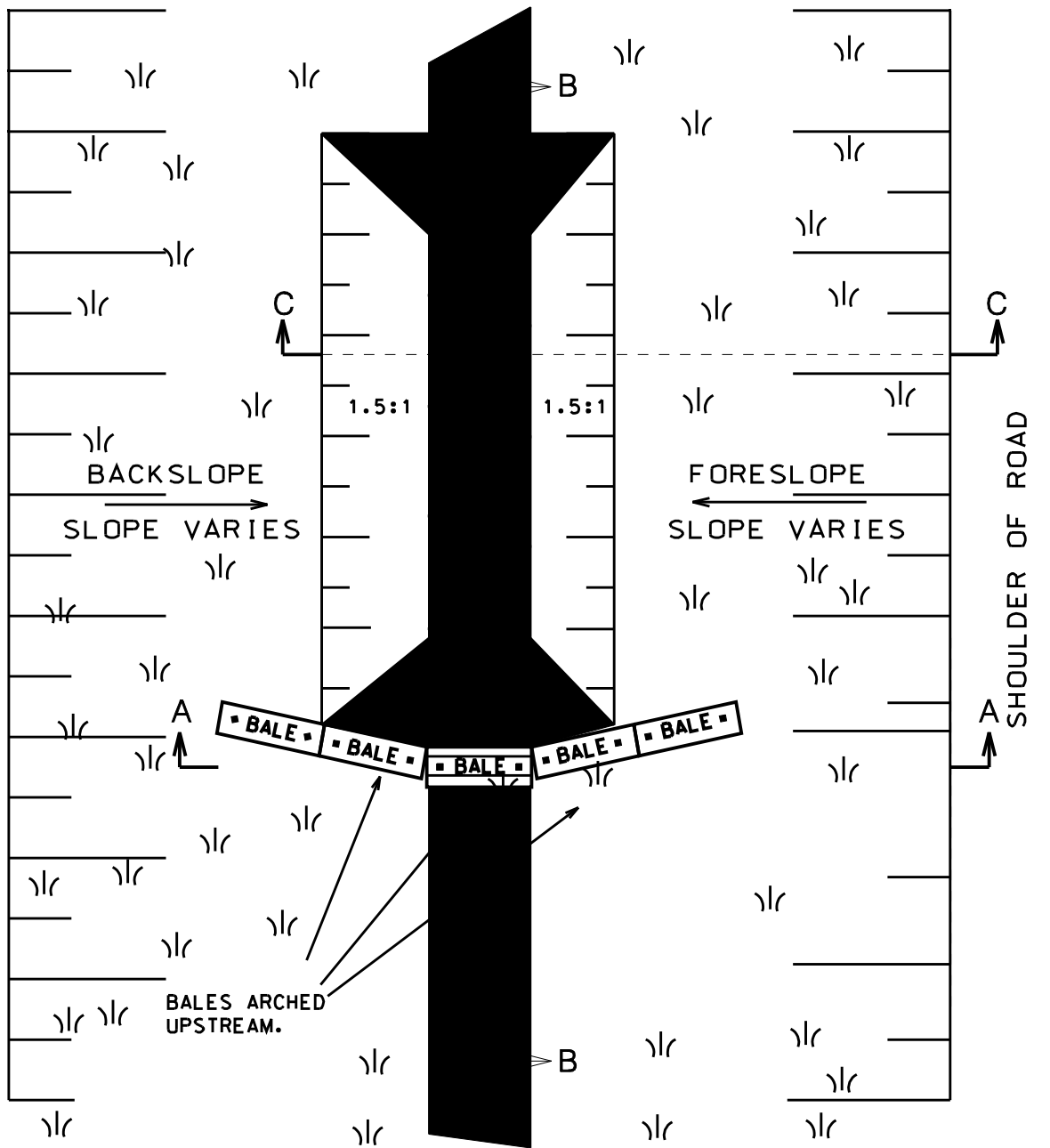

PLAN VIEW (N.T.S.)

Notes:

1. Number of bales required varies depending on backslope and foreslope and ditch width/depth.
2. Depth, width and sideslopes of sediment pit may vary with soil conditions as directed by engineer.
3. See Figure 801-4 for section details.

**FIGURE 801-03 STRAW BALE CHECK DAM**  
**REVISED 2002**

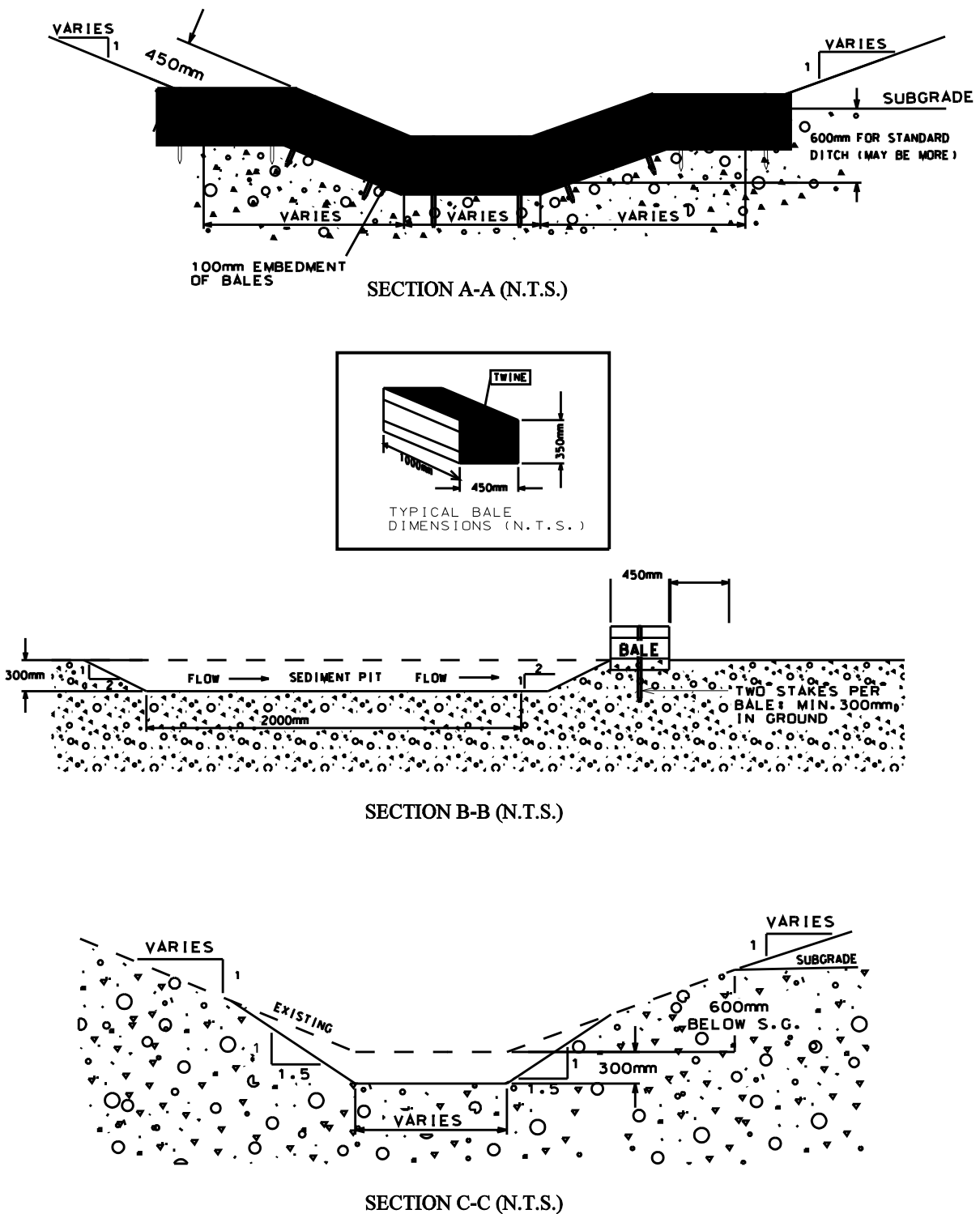

**FIGURE 801-04 SECTION DETAILS FOR STRAW BALE CHECK DAM  
 REVISED 2002**

**GENERAL PROVISIONS AND CONTRACT SPECIFICATIONS  
FOR HIGHWAY CONSTRUCTION**

DEPARTMENT OF TRANSPORTATION AND PUBLIC WORKS

---

**WATER FOR DUST CONTROL**

**802**

802.01 Description

This work shall consist of supplying and placing water to be used for dust control.

802.02 Construction Method

Locations where water is to be applied, the amount of water to be applied and the times at which it shall be applied shall be determined by the Engineer.

At least one mobile water application unit of at least 4.5 kℓ capacity for applying water shall be available on the work site at all times. Water shall be applied by means of a pressure type distributor equipped with a spray system of nozzles that will ensure a uniform application of water.

The intake hose to the tank shall be equipped with a device satisfactory to the Engineer to prevent fish from being pumped into the tank.

802.03 Method of Measurement

Measurement for payment under this Section shall be the volume of water applied as directed by the Engineer measured in kilolitres.

802.04 Basis of Payment

Payment under this Section shall be at the unit bid price per kilolitre of water applied and this price shall be full compensation for supply, transportation and placement of water for dust control, tools, labour, equipment, materials and incidentals necessary to perform the work.

**GENERAL PROVISIONS AND CONTRACT SPECIFICATIONS  
FOR HIGHWAY CONSTRUCTION**

DEPARTMENT OF TRANSPORTATION AND PUBLIC WORKS

---

**HYDRO SEEDING**

**803**

803.01 Description

This work shall consist of hydraulically seeding areas designated by the Engineer adjacent to the highway to produce a uniform cover of grasses. Once established, the grasses will protect against erosion and sedimentation, reduce runoff flow velocities and improve infiltration, and provide for sediment removal (buffer strip).

803.02 Material

The composition of seed shall be Canada No. 1 Mixture as defined by Table 803-1.

The following proportion of seeds should be added as a "nurse crop" to the Canada No. 1 Mixture of Table 803-1.

May 1 - July 31: Add 25% oats, minimum seed purity 98%, minimum germination 80%.

Aug. 1- Sept 30:           Add 25% winter rye, minimum seed purity 98%, minimum germination 85%.

A nurse crop is a quick growing annual added to permanent mixtures that germinates and grows rapidly holding the soil until the slower growing perennial seedlings become established.

**Table 803-1   Composition of Seed Mixture**

<b>Mixture Composition (Canada No. 1)</b>	<b>Proportion (%)</b>	<b>Germination (%)</b>	<b>Purity (%)</b>
Creeping Red Fescue	55	85	97
Red Top Canada	5	94	98
Timothy	10	92	96
Kentucky Blue Grass	10	85	98
White Dutch Clover	10	90	94
Perennial Rye Grass	10	95	98

The mixture for mulching and seeding shall, for each 1000 l of water, consist of 5 kg of seed mixture, 50 kg of 10-10-30 fertilizer, 220 kg of dolomitic lime and 60 kg of hydraulic mulch material.

The hydraulic mulch material shall be capable of dispersing rapidly in water to form a homogeneous slurry and of remaining in this state when agitated or mixed with other specified materials. When applied, the hydraulic mulch shall be capable of forming an absorptive mat, which will allow moisture to percolate into the underlying soil. It shall contain no growth or germination inhibitor. The mulch shall be dry, be free of weeds and all other foreign material and shall be supplied in packages indicating the weight.

**GENERAL PROVISIONS AND CONTRACT SPECIFICATIONS  
FOR HIGHWAY CONSTRUCTION**

DEPARTMENT OF TRANSPORTATION AND PUBLIC WORKS

---

**HYDRO SEEDING**

**803**

The hydraulic mulch shall be a mixture consisting of cellulose pulp and natural sun-dried fibres processed in 20 mm minimum and 25 mm maximum lengths.

**803.03 Construction Method**

After the areas to be treated have been brought to grade and the topsoil returned, they shall be harrowed to bring the top 50 mm to a loose friable condition. This area shall be left with a true uniform smooth surface. Any stones greater than 50 mm shall be removed and disposed of.

Hydro seeding shall not be permitted on hardened or crusted soil. Areas to be hydro seeded shall be dressed as above or otherwise left in a loosened condition free of ruts, ridges or deleterious materials such as sticks, roots or large rocks.

Hydro seeding shall be carried out as soon as possible after completing surface preparation.

Depending on conditions and the size of the project, the Engineer may required that hydro seeding be done in stages as the work progresses.

The hydraulic method of seeding and mulching shall be used. The work shall be done with an approved machine operated by a competent crew. The materials shall be mixed with water in the tank of the machine and kept agitated to ensure a uniform mix and suspension at all times during the operation. The equipment must be designed and operated to uniformly distribute seed, fertilizer and mulch on the designated areas at the rates specified.

The rate of application shall be 22.5 kℓ of mixture per hectare.

Seeded shoulders shall be rolled to the satisfaction of the Engineer.

Areas of poor growth which exceed five percent of the total area seeded shall be reseeded. The success of the seeding will be judged on its growth at the end of the growth season.

No work under this Section shall be carried out prior to May 1 or after September 30 without written approval from the Engineer.

Hydro seeding should not be performed under windy conditions or during periods of rainfall, in standing water, or under adverse conditions, as determined by the Engineer.

Within 30 m of a watercourse, the following schedule will apply:

- if hydro seeding prior to June 1 or after September 30, the hydro seed shall be completely covered with an erosion control material within 48 hours. This material shall be either: (a) Mulching "1" (as per Section 805) covered with jute mat (as per Section 807); or (b) erosion control blanket (as per Section 807).
- if, due to lateness of the season, hydro seeding is not possible, the exposed area shall be completely covered for "over-wintering" with an erosion control material being either: (a) Mulching "1" (as per Section 805) covered with jute mat (as per Section 807); or (b) erosion control blanket (as per Section 807). Then, early in the next growing season, the erosion control material shall be removed, the area shall be

**GENERAL PROVISIONS AND CONTRACT SPECIFICATIONS  
FOR HIGHWAY CONSTRUCTION**

DEPARTMENT OF TRANSPORTATION AND PUBLIC WORKS

---

**HYDRO SEEDING**

**803**

harrowed, smoothed and stones removed as described above, and then hydro seeded.

803.04 Maintenance

The Contractor shall inspect regularly and after rainfalls of 5 mm or more accumulation, and re-seed areas as required until the area has stabilized.

Additional fertilizer may be applied to facilitate thicker growth.

The Contractor shall not remove sediment control structures until the seeded area has been properly stabilized. Disturbed areas shall be levelled and seeded.

803.05 Method of Measurement

Measurement for payment under this Section shall be the area of land hydro seeded and measured in square metres.

Measurement for payment for any required erosion control material shall be as per the applicable sections (i.e. Section 805 Mulching and Section 807 Erosion Control Mats) for specified materials.

803.06 Basis of Payment

Payment under this Section shall be at the unit bid price per square metre and this price shall be full compensation for preparation of the area to be hydro seeded, supply of the hydro seed mixture, placement of the mixture, all tools, labour, equipment, materials and other incidentals necessary to perform the work.

Payment for any required erosion control material shall be as per the applicable sections (i.e. Section 805 Mulching and Section 807 Erosion Control Mats) for specified materials.

**GENERAL PROVISIONS AND CONTRACT SPECIFICATIONS  
FOR HIGHWAY CONSTRUCTION**

DEPARTMENT OF TRANSPORTATION AND PUBLIC WORKS

---

**SEEDING**

**804**

804.01 Description

This work shall consist of seeding areas as designated by the Engineer.

804.02 Material

Grass seed shall be certified No. 1 Grade, Government of Canada Seeds Regulation, with a minimum germination of 75% and a minimum purity of 97%. The grass seed mixture shall be as recommended by the Department of Agriculture. Fertilizer shall be completely synthetic, slow release fertilizer with maximum 35% water soluble nitrogen. Fertilizer to contain proportions of nitrogen, phosphoric acid and potash as recommended for the area by the Department of Agriculture.

804.03 Construction Method

The Contractor shall cultivate areas to be seeded to 100 mm depth and shall fine grade the area free from humps and hollows and free of deleterious and refuse material. Waste material shall be disposed of in accordance with Provision 104.14. Commercial fertilizer shall be spread and raked at a rate of 2.3 kg per 93 m<sup>2</sup> on areas to be seeded.

The Contractor shall seed the designated area during early spring or between August 15 and October 15. Sow during calm weather using suitable equipment to the approval of the Engineer. Spread seed evenly at a rate of 2.3 kg per 93 m<sup>2</sup>. Sow half of the required amount of seed in one direction and the remainder at right angles. Incorporate seed into soil to a minimum depth of 5 mm. Mix carefully with a light chain harrow or wire rakes and roll area immediately afterward with a water ballast type lawn or agricultural type roller.

Lawns planted during the spring season shall be maintained after planting and as long as is necessary to establish a close stand of grass, free of weeds and undesirable grasses. Lawns planted during the fall planting season shall be maintained in the same manner as for spring planting but they shall not be deemed acceptable until the following July 1st, provided a lawn of close stand of grass of varieties specified free of weeds and undesirable grasses is established.

The Contractor shall apply water immediately after rolling with a fine spray to a depth penetration of at least 50 mm. Water shall be potable and free of impurities that would inhibit germination.

804.04 Method of Measurement

The quantity to be measured under this Section shall be the number of square meters of seeding deemed acceptable by the Engineer.

804.05 Basis of Payment

Seeding shall be paid for at the unit bid price per square metre and this price shall be full compensation for materials, equipment tools, labour and incidentals necessary to complete the work.



**GENERAL PROVISIONS AND CONTRACT SPECIFICATIONS  
FOR HIGHWAY CONSTRUCTION**

DEPARTMENT OF TRANSPORTATION AND PUBLIC WORKS

---

**MULCHING**

**805**

---

805.01 Description

This item consists of the supply and application of hay or straw as a mulch on slopes and other exposed ground including selected sensitive ditch locations as directed by the Engineer. This is a temporary measure to control erosion, and thereby minimizing the transfer of sediment-laden runoff to watercourses, by protecting the soil surface from raindrop impact, reducing the velocity of overland flow, fostering the growth of vegetation by reducing moisture loss, and providing insulation against extreme heat and cold.

805.02 Material

Hay or straw mulch shall be supplied by the Contractor. It shall be reasonably free of noxious weeds and other undesirable materials. It shall not be so wet, decayed or compacted that it inhibits even and uniform spreading.

Hay mulch is the preferred material over straw mulch for areas that are to become vegetated. However, when mulching for overwintering protection, straw mulch should be used.

Binder (tackifier) may be supplied in liquid, powder or flake form.

805.03 Construction Method and Maintenance

Prior to mulching, complete the required grading and surface roughening.

Remove large rocks and other debris that may prohibit uniform coverage.

To avoid the mulch from being blown around, the length of hay or straw should be chopped to 200-300 mm. Mulching should be spread by the use of mechanical means such as a bale buster unless the job is small enough to be done by hand.

Hay or straw mulch (unprocessed mulch) shall be spread evenly and uniformly over the designated areas at a rate of 4500 kg per hectare (approximately 300 standard size bales or 7, 1.8 m round bales) plus or minus 10 %, depending on the type of ground and the slope steepness. Lumps and thick clumps of mulch shall be thinned.

The hay or straw mulch shall be applied promptly on the exposed ground surface as soon as practicable after the ground has been worked and shaped to the Engineer's satisfaction.

Mulch applied between June 1st and September 30th may or may not require binder at the Engineer's discretion. All mulching before June 1st and after September 30th shall require binder.

Mulching without binder shall be designated as Mulching "1".

Mulching with binder shall be mixed in a hydro seeding unit with water, etc. and shall be designated as Mulching "2" (also known as processed mulch). Binder shall be added at the manufacturer's recommended application rate, and Mulching "2" shall be sprayed uniformly over the designated areas at a rate of 2,200 kg per hectare plus or minus 15%, depending on the type of ground and the slope steepness.

**GENERAL PROVISIONS AND CONTRACT SPECIFICATIONS  
FOR HIGHWAY CONSTRUCTION**

DEPARTMENT OF TRANSPORTATION AND PUBLIC WORKS

---

**MULCHING**

**805**

---

Mulched areas should be inspected regularly and after rainfalls of 5 mm or more accumulation and repaired as required, until the area has stabilized.

The Contractor shall maintain the mulch by repairing all damaged mulch and by re-mulching bare spots resulting from the shifting of mulch by wind, water or other means. This shall include additional mulch as required.

805.04 Method of Measurement

Measurement for payment under this Section shall be the number of square metres of ground surface acceptably mulched.

805.05 Basis of Payment

805.05.01 Mulching "1"

805.05.02 Mulching "2"

Mulching shall be paid for at the unit bid price per square metre and this price shall be full compensation for all materials, tools, labour, equipment and incidentals necessary to perform and maintain the work.

Re-mulching of bare spots caused by the shifting of the mulch by wind, water or other cause beyond the control of the Contractor will also be measured for payment at the unit bid price at the discretion of the Engineer.

The supply, mixing and application of binder for Mulching "2" will not be measured for payment but will be considered as incidental to the work.

**GENERAL PROVISIONS AND CONTRACT SPECIFICATIONS  
FOR HIGHWAY CONSTRUCTION**

DEPARTMENT OF TRANSPORTATION AND PUBLIC WORKS

---

**SILT FENCES**

**806**

806.01 Description

Work under this Section will consist of the construction of silt control fences at locations as indicated on Plans or by the Engineer. Silt fencing is commonly used to surround a disturbed work site.

806.02 Type 1 Silt Fence

Type 1 silt fences are used on land as a temporary sediment control measure in situations where sheet or overland flows are expected.

The silt fence shall be installed just up-slope of the area to be protected in order to prevent silt from being conveyed to an adjacent property or watercourse/ wetland.

The silt fence may be setback from the toe of slopes provided that sufficient area is available. This provides for more sediment storage area and locates the fence where runoff velocities are lower.

806.02.01 Material

Geotextile filter fabric shall be 600 mm in width and conform to the minimum requirements of Table 806-1.

Wooden stakes shall be 50 mm square and a minimum length of 1.5 m.

Staples will be heavy duty wire staples of 25 mm minimum length.

**Table 806-1 Requirements for Geotextile Filter Fabric For Type 1 Silt Fence**

<b>Property</b>	<b>Min.</b>	<b>ASTM</b>
Grab Tensile Strength (N)	400	D-4632
Elongation at Break Point (%)	25 max.	D-4632
Permativity (cm/s)	0.230	D-4491
Apparent Opening Size (µm)	480	D-4751
UV Degradation (%)	70	D-4355

**GENERAL PROVISIONS AND CONTRACT SPECIFICATIONS  
FOR HIGHWAY CONSTRUCTION**

DEPARTMENT OF TRANSPORTATION AND PUBLIC WORKS

---

**SILT FENCES**

**806**

806.02.02      Construction Method

At designated locations, the Contractors will excavate a 100 mm x 100 mm trench on the up-slope side of the fence as shown in Figure 806-1. The silt fence may be set back from the toe of slopes, area permitting and provided setbacks are maintained. This provides more sediment storage area and lowers runoff velocities.

The Contractor shall drive the sturdy 50 mm square wooden stakes, spaced 2 m apart, at least 400 mm into the ground along the down-slope side of the trench. The filter fabric will be in a continuous roll cut to the length of the barrier to avoid joints. When joints are unavoidable, filter fabric will be spliced together on a support stake with a minimum 150 mm overlap.

The filter fabric will be attached to the stake on the upstream side extending the bottom 200 mm into the trench as shown on Figure 806-1 using 25 mm heavy duty wire staples.

The Contractor shall backfill and compact the excavated soil in the trench over the filter fabric.

Prefabricated silt fence systems, at the discretion of the Engineer, may be used if they meet the above material requirements. They will be installed as per the manufacturer's instructions should they differ from the above method.

806.02.03      Maintenance

The Contractor shall contain sediment runoff and maintain the silt fence in a functional condition as long as necessary as follows:

- inspect all silt fences after each rainfall and at least daily during periods of prolonged rainfall;
- all silt fences or parts thereof that are damaged will be repaired immediately to the satisfaction of the Engineer;
- trapped sediment will be removed when it has accumulated to a level half the height of the fence and will be disposed of at a location approved by the Engineer.

The Engineer may require that some or all silt fences be maintained after substantial completion of the work.

806.02.04      Decommissioning

If specified by the Engineer, the Contractor shall remove the silt fence at the completion of the job and dress and seed the area to the satisfaction of the Engineer.

At the discretion of the Engineer, the Contractor shall gather silt fencing and stakes that are no longer required and place these in neat piles for collection and reuse by the Engineer.

**GENERAL PROVISIONS AND CONTRACT SPECIFICATIONS  
FOR HIGHWAY CONSTRUCTION**

DEPARTMENT OF TRANSPORTATION AND PUBLIC WORKS

---

**SILT FENCES**

**806**

806.02.05     Method of Measurement

Measurement for payment for Type 1 Silt Fence under this Section will be the number of linear metres of silt fence installed.

806.02.06     Basis of Payment

Type 1 Silt Fences will be paid for at the unit bid price per linear metre. This price will be full compensation for supplying, placing, maintaining and decommissioning of all items required to carry out the work as specified herein and as instructed by the Engineer.

Maintenance and decommissioning that is required after substantial completion of the site work shall be paid for under Section 810.

806.03   Type 2 Silt Fence

Type 2 Silt Fences are used in or alongside aquatic environments. The Type 2 silt fence is similar to the Type 1 silt fences used on land. They are typically used along the toe of slopes of embankments that are constructed in a tidal zone of a river or an estuary. They will be configured in accordance with Figure 806-2.

806.03.01    Materials

The Geotextile filter fabric for the Type 2 Silt Fence and the Silt Boom will conform to the minimum requirements of Table 806.03.01.

**Table 806.03.01           Requirements for Geotextile Filter Fabric For Type 2 Silt Fences and Silt Booms**

<b>Property</b>	<b>Woven</b>	<b>Non-woven</b>	<b>Test Method</b>
Grab Tensile Strength (N)	1275	1000	Can 2-4.2-M77
Mullen Burst (kPa)	3600	2500	Can 2-4.2-M77
Tear Strength (N)	475	475	Can 2-4.2-M77
Elongation at Break (%)	18	70-100	Can 2-4.2-M77
Filtration Opening Size (um)	220	60	MOT, Ont.

**Note:** Because of the smaller Filtration Opening Size of the non-woven material, it is recommended that this material be used in dredging projects.

For the Type 2 Silt Fence, all posts will consist of a local species, non-treated timber. The posts will be planed smooth and be straight and true to line. Post lengths will vary and be 150 mm X 150 mm as a minimum. The geotextile material will be fastened to the posts by wooden laths.

**GENERAL PROVISIONS AND CONTRACT SPECIFICATIONS  
FOR HIGHWAY CONSTRUCTION**

DEPARTMENT OF TRANSPORTATION AND PUBLIC WORKS

---

**SILT FENCES**

**806**

806.03.02     Construction Method

The Contractor shall, for Type 2 Silt Fence, drive posts along the required alignment to a point where support for the fence is attained and cut posts off 500 mm above HHW.

The Contractor shall install geotextile fabric to the posts using the wooden laths; overlap fabric as required to ensure connections are tight and place rip rap along the bottom of the geotextile fabric as shown in Figure 806-02.

806.03.03     Maintenance

The Type 2 Silt Fence will be maintained in a like new condition. Repairs required because of damages will be made immediately or as instructed by the Engineer.

A sufficient amount of replacement geotextile filter fabric and posts will be maintained on site for emergency repairs.

806.03.04     Decommissioning

Following completion of all construction activities in the contract, the contractor will dismantle the Type 2 Silt Fence. This work will include the removal of all posts, bracing, rip rap, fabric and all other items incorporated into the work.

At the discretion of the Engineer, the Contractor shall gather silt fence materials including fabric, posts, riprap and bracing that are no longer required and place these in neat piles for collection and reuse by the Engineer.

806.03.05     Method of Measurement

Measurement for payment for Type 2 Silt Fence under this Section will be the number of linear metres of silt fence installed.

806.03.06     Basis of Payment

Measurement for payment for Type 2 Silt Fence under this section will be on a linear metres basis for the supply , placing, maintaining and decommissioning of all items required to carry out the work as specified herein and as instructed by the engineer.

There will be no separate payment for the supply and placing of posts, bracing, geotextile filter fabric, rip rap, connections or any other items.

**GENERAL PROVISIONS AND CONTRACT SPECIFICATIONS  
FOR HIGHWAY CONSTRUCTION**

DEPARTMENT OF TRANSPORTATION AND PUBLIC WORKS

---

**SILT FENCES**

**806**

806.04 Silt Boom

Silt booms are used in aquatic environments and are anchored at the bottom but have a floating boom at the top to keep the boom or containment structure above the water level. Silt Booms are particularly used in dredging projects. They minimize sediment transport from a disturbed area of work so as to provide a stagnant area. They will be in accordance with Figure 806-03.

806.04.01 Materials

The Geotextile filter fabric for the Silt Boom will conform to the minimum requirements of Table 806.03.01.

Flotation, whether PVC pipe or foam, will have sufficient buoyancy to provide continuous support and a minimum 50 mm freeboard. Typical flotation should be a minimum 100 mm diameter.

Silt curtain load lines attached along the flotation material will be 8 mm steel cable or 19 mm nylon or polypropylene rope.

Silt curtain ballast should be 8 or 10 mm steel chain.

806.04.02 Construction Method

The silt curtain of the boom will have a sleeve sewn along the entire top edge so as to contain the flotation and the load line within the sleeve. A sleeve is also sewn along the bottom edge so as to contain the ballast. The ballast will hold the fabric down and prevent sediment laden water from seeping out under the bottom of the curtain.

The silt boom should be placed a minimum of 5 metres beyond the work area. The silt curtain depth should be 450 mm deeper than the water depth.

Anchors (kedge anchors, concrete blocks, danforth anchors) will be used to provide positive positioning to ensure the silt curtain will not be dislocated.

806.04.03 Maintenance

The silt boom will be maintained in a like new condition. Repairs required because of damages will be made immediately or as instructed by the Engineer.

A sufficient amount of replacement geotextile filter fabric and floatation material will be maintained on site for emergency repairs.

**GENERAL PROVISIONS AND CONTRACT SPECIFICATIONS  
FOR HIGHWAY CONSTRUCTION**

DEPARTMENT OF TRANSPORTATION AND PUBLIC WORKS

---

**SILT FENCES**

**806**

806.04.04     Decommissioning

Following completion of all construction activities in the contract, the contractor will dismantle the entire Silt Boom. This work will include the removal of all flotation, silt curtains fabric, steel cable, steel chain anchors and all other items incorporated into the work.

806.04.05     Method of Payment

Measurement for payment under this section will be on a linear metre basis for the supply, placing, maintaining and decommissioning of all items required to carry out the work as specified herein and as instructed by the engineer.

806.04.06     Basis of Payment

Work done under this section will be paid for at the linear metre bid price. The bidder will include in the linear metre bid price all costs of labour, tools, equipment, materials, installation, maintenance, decommissioning and incidentals to complete the work to the satisfaction of the engineer.



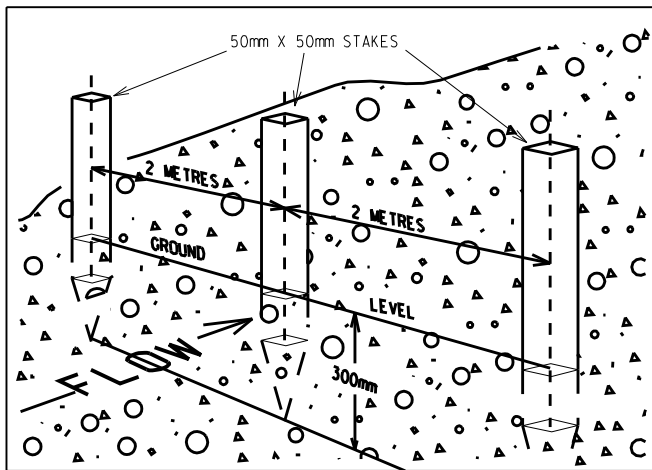

1. Set the stakes 2 metres c/c and a minimum of 300mm into the ground

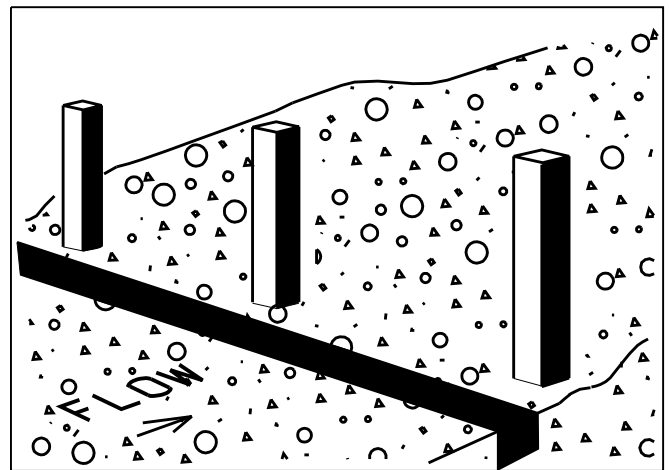

2. Excavate a 100mm x 100mm trench just upslope and along the line of the stakes.

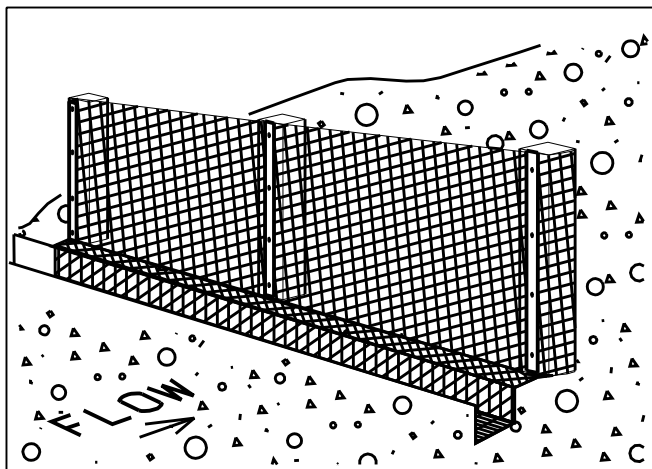

3. Staple filter material to the stakes and extend the bottom into the trench. Face material with a 40mm lathe nailed vertically to each the stake.

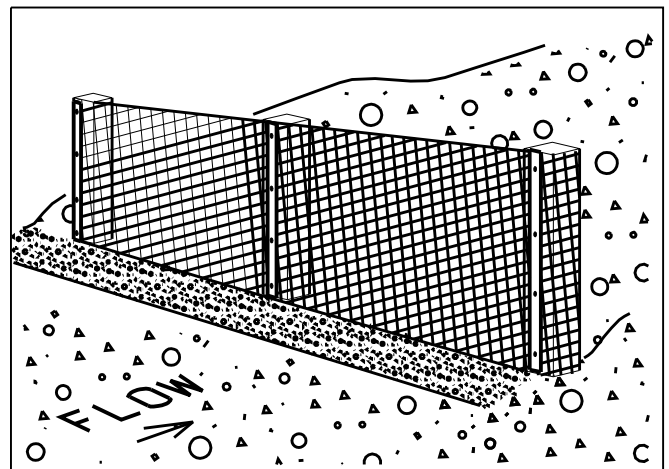

4. Backfill and compact the excavated soil.

### PERSPECTIVE VIEWS (N.T.S.)

Note: If prefabricated fence is used, use the manufacturers installation specifications.

**FIGURE 806-01 CONSTRUCTION OF A TYPE 1 SILT FENCE**

**REVISED 2001**

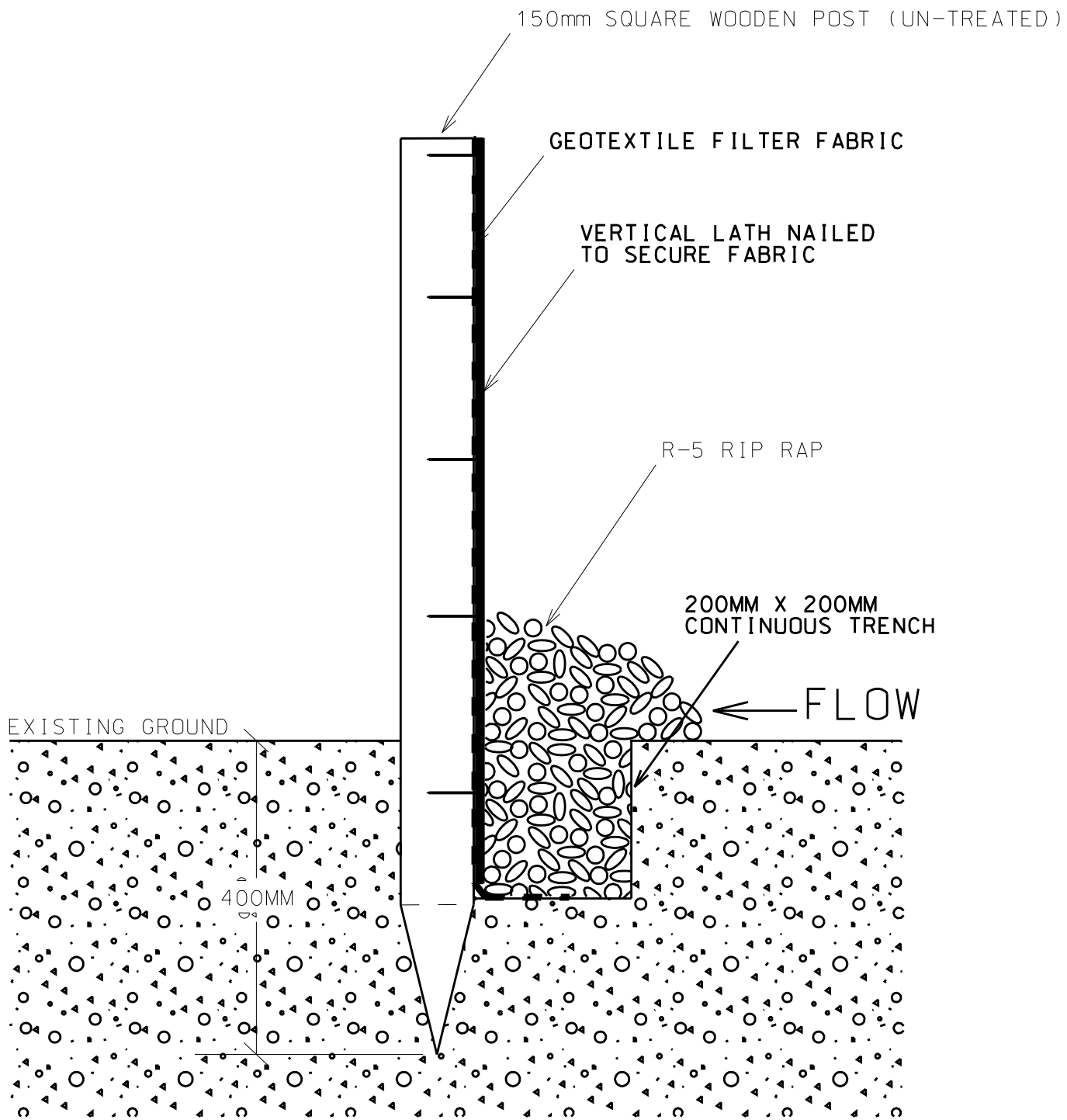

SECTION (N.T.S.)

FIGURE 806-02 TYPE 2 SILT FENCE

REVISED 2001

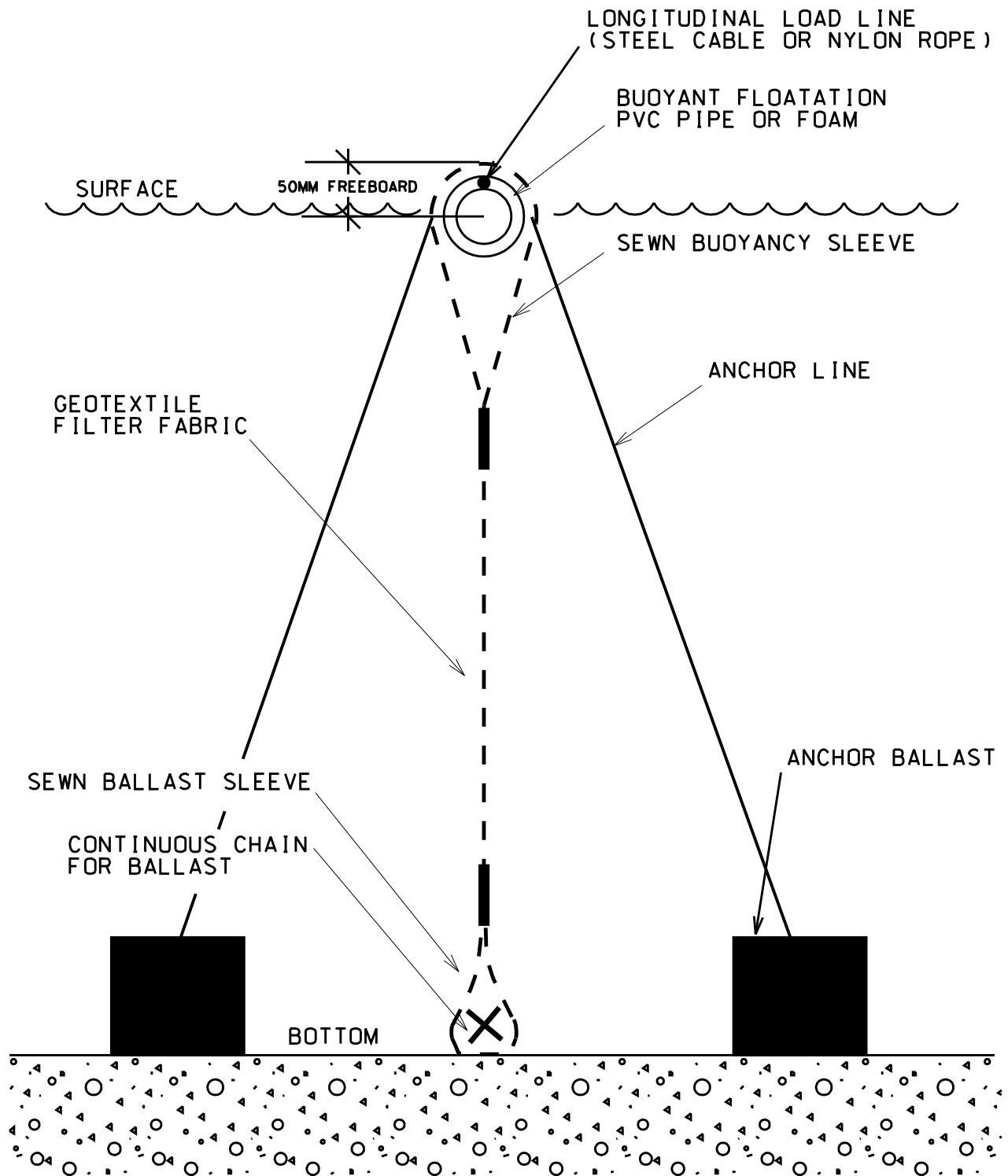

SECTION (N.T.S.)

FIGURE 806-03 SILT BOOM

REVISED 2001

**GENERAL PROVISIONS AND CONTRACT SPECIFICATIONS  
FOR HIGHWAY CONSTRUCTION**

DEPARTMENT OF TRANSPORTATION AND PUBLIC WORKS

---

**EROSION CONTROL MATS**

**807**

807.01 Description

The work in this Section consists of the installation of temporary erosion control mats, either jute mat or erosion control blankets, to protect newly seeded soils from erosion caused by overland flows or to provide cover for overwinter protection of late season grading work. Note that, throughout this Section, the term erosion control mat pertains to both (a) jute mat and (b) the various types of erosion control blankets.

These mats are for application on steep slopes and stream banks where erosion hazard is high, in newly constructed ditch areas located just upstream of watercourses that are seeded outside of the normal construction period (refer to Section 803 Hydro seeding), in areas where moving water is likely to wash out new vegetation (e.g., in grassed waterways, diversion ditches, and drainage ditches), and where mulch is applied and wind protection is important. As well, erosion control material is recommended for the back slope, fore slope and bottom of ditches where the ditch is located within 30 m of a watercourse and the ditch gradient is greater than 5%.

807.02 Material Types

The selection of erosion control mat type is dependant upon many factors including slope, water flow volume and velocity, the length of time that temporary protection is required, and area sensitivity.

For all erosion control mat types, staples for anchoring the mat shall be U-shaped No. 11 gauge wire or heavier. Their length shall be 150 mm to 300 mm, with the longer staples used on loose, sandy or unstable soils.

*Jute Mat*

#1 For low to moderate embankment slopes, and for low flow channels where protection is required for a short period before vegetation is established, Jute Mat is recommended.

#2 Jute Mat is useful as a cover material for mulched areas.

Jute Mat shall be a cloth of uniform plain weave of undyed and unbleached single jute yarn, 1.22 mm in width plus or minus 25 mm and weighing an average of 600 g/per linear metre with a tolerance of plus or minus 5%. The yarn shall be of a loosely twisted construction having an average twist of not less than 1.6 turns per 25 mm and shall not vary in thickness by more than ½ its normal diameter.

---

*Erosion Control Blanket - Straw Blanket*

For moderate to steep embankment slopes and low flow channels where protection is required for a short period before vegetation is established, a straw blanket is recommended. Depending on the erosion conditions, the straw blanket will be sewn together by either a single biodegradable net on top or by a straw filter matrix between two biodegradable nets.

**GENERAL PROVISIONS AND CONTRACT SPECIFICATIONS  
FOR HIGHWAY CONSTRUCTION**

DEPARTMENT OF TRANSPORTATION AND PUBLIC WORKS

---

**EROSION CONTROL MATS**

**807**

*Erosion Control Blanket - Straw-Coconut Fibre Blanket*

For severe embankment slopes and medium flow channels requiring long-term protection before vegetation is established, a straw-coconut fibre blanket is recommended. This blanket shall include ultraviolet stabilized netting and a high quality straw, either single or double matrix, supplemented with coconut fibre or an excelsior blanket of curled wood excelsior of 80% 150 mm or longer fibre, covered on top with a biodegradable plastic mesh.

*Erosion Control Blanket - Coconut Blanket*

For extreme embankment slopes and high velocity flow channels, and for applications requiring semi-permanent to permanent protection and vegetal reinforcement, a coconut blanket is recommended. This blanket shall include a 100% coconut filter matrix between two heavy duty, ultra violet stabilized nets or curled wood excelsior blanket of 80%, 150 mm or longer fibre and with each side covered with black, extra heavy duty extruded plastic mesh netting.

**807.03 Construction Method**

Figures 807-1 and 807-2 correspond to the text in this Section, and are applicable for both jute mat and erosion control blanket installations.

After the site has been shaped and graded to the approved design, the Contractor shall prepare a uniformly even seedbed relatively free from gullies, large roots, rocks greater than 40 mm in diameter, and other debris/obstructions that will prevent uniform contact of the protective covering with the soil surface.

***The most critical aspect of installing erosion control mats is obtaining firm, continuous contact between the material and the mulch and/or the soil. Without good contact, erosion may occur.***

The Contractor shall not stretch the mat material but allow it to lay loosely on the soil.

In ditches or channels, the erosion control mat is to be laid out in the direction of flow. On steep slopes, the mat is to be laid out with its length extending from the top to the bottom of the slope. The Contractor shall start laying the mat from the top of the ditch or slope and unroll down grade.

Anchor slots: At the up slope end of the site, the Contractor shall construct a 150 mm deep trench and staple the upper edge of the matting into the trench using staple spacing of 300 mm; then backfill and firmly compact the trench (i.e., anchor slot.)

Overlap: Where the erosion control mat lengths are laid side by side on the down slope, the sides will be overlapped by a minimum of 100 mm, and the overlapped materials will be stapled down the centre of the overlap every 450 mm, making sure the mat material is smooth and in firm contact with the soil.

Where mat lengths are installed with no overlap, staple spacing along their outside edges can be 600 mm.

Joining Lengths of Erosion Control Mat: Where two mat lengths must be joined end-to-end, the down slope mat shall be first stapled into an anchor slot trench which shall be backfilled and compacted as outlined above. Then, the up slope mat shall be laid overtop of the finished

**GENERAL PROVISIONS AND CONTRACT SPECIFICATIONS  
FOR HIGHWAY CONSTRUCTION**

DEPARTMENT OF TRANSPORTATION AND PUBLIC WORKS

---

**EROSION CONTROL MATS**

**807**

anchor slot, overlapping the slot and the exposed down slope mat by 300 mm. The overlap shall be then stapled at 300 mm spacing on centre.

Additional Erosion Check Slots: On slopes or ditches more than 30 m long, there should be an erosion check slot installed at 15 m intervals. Check slots are trenches 100 mm deep by 100 mm wide. During the mat lay out process, the mat shall be installed in the trench, stapled at 300 mm spacing along the down slope side of the trench, and then the mat will continue to be laid (on the down slope side of the ditch or slope). The trench shall be backfilled and the soil compacted firmly. It may be beneficial to determine the need for erosion check slots, and construct the trenches accordingly, before laying the erosion control mat.

All staples are to be flush with the ground and secured as per the manufacturer's specifications. Additional staples may be required to secure the erosion control mat in depressions.

The Contractor shall make sure that the erosion control mat is well anchored so that it does not slip or wash out.

Any water that may accumulate underneath the fabric must be prevented from moving downward with sufficient velocity to cause erosion.

If a berm or dyke is located at the top of the slope, the Contractor shall extend the erosion control mat over the berm and anchor it behind the berm.

At a point where the erosion control mat is discontinued or where the mat meets a structure, the Contractor shall fold 100 mm of the material underneath and staple at a minimum interval of every 300 mm across the width of the mat.

If the manufacturer's installation requirements are more stringent than those identified above, then the manufacturer's requirements are to be followed.

**807.04 Maintenance**

Inspect regularly and after rainfalls of 5 mm or more accumulation, and repair areas if/as required, until the area has stabilized.

Do not remove sediment control structures until the area has been properly stabilized.

**807.05 Method of Measurement**

The areas covered with the erosion control mat as outlined in Provision 807.03 shall be measured for payment in square metres and no compensation for mat overlap will be considered.

**807.06 Basis of Payment**

Payment under this Section shall be at the unit bid price per square metre for the erosion control mat as specified and this price shall be full compensation for all labour, equipment, material, mats or blankets, staples, maintenance, materials and incidentals necessary to perform the work.

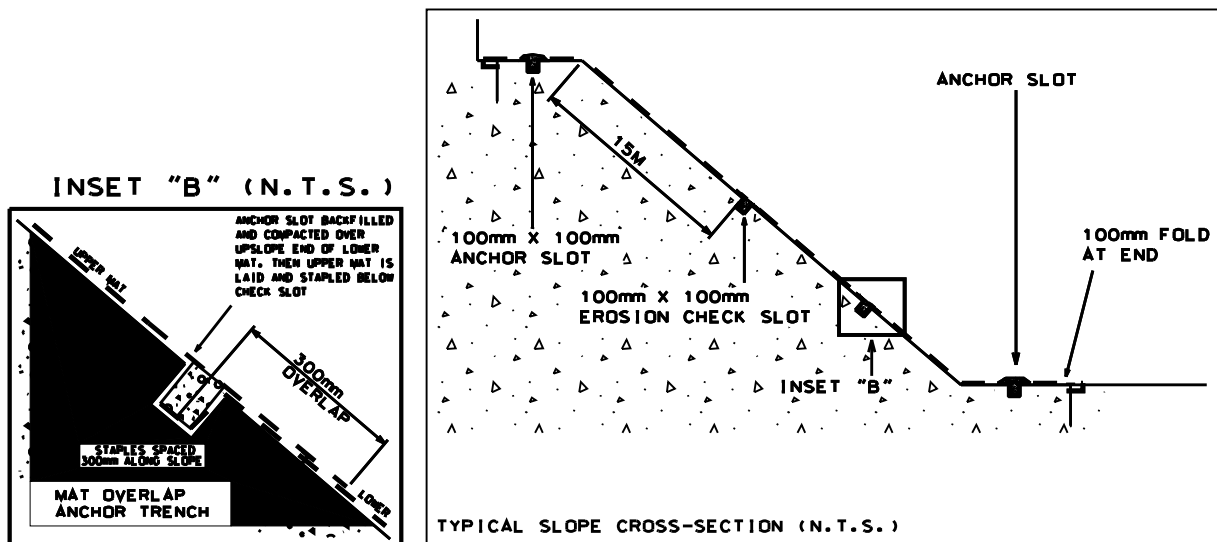
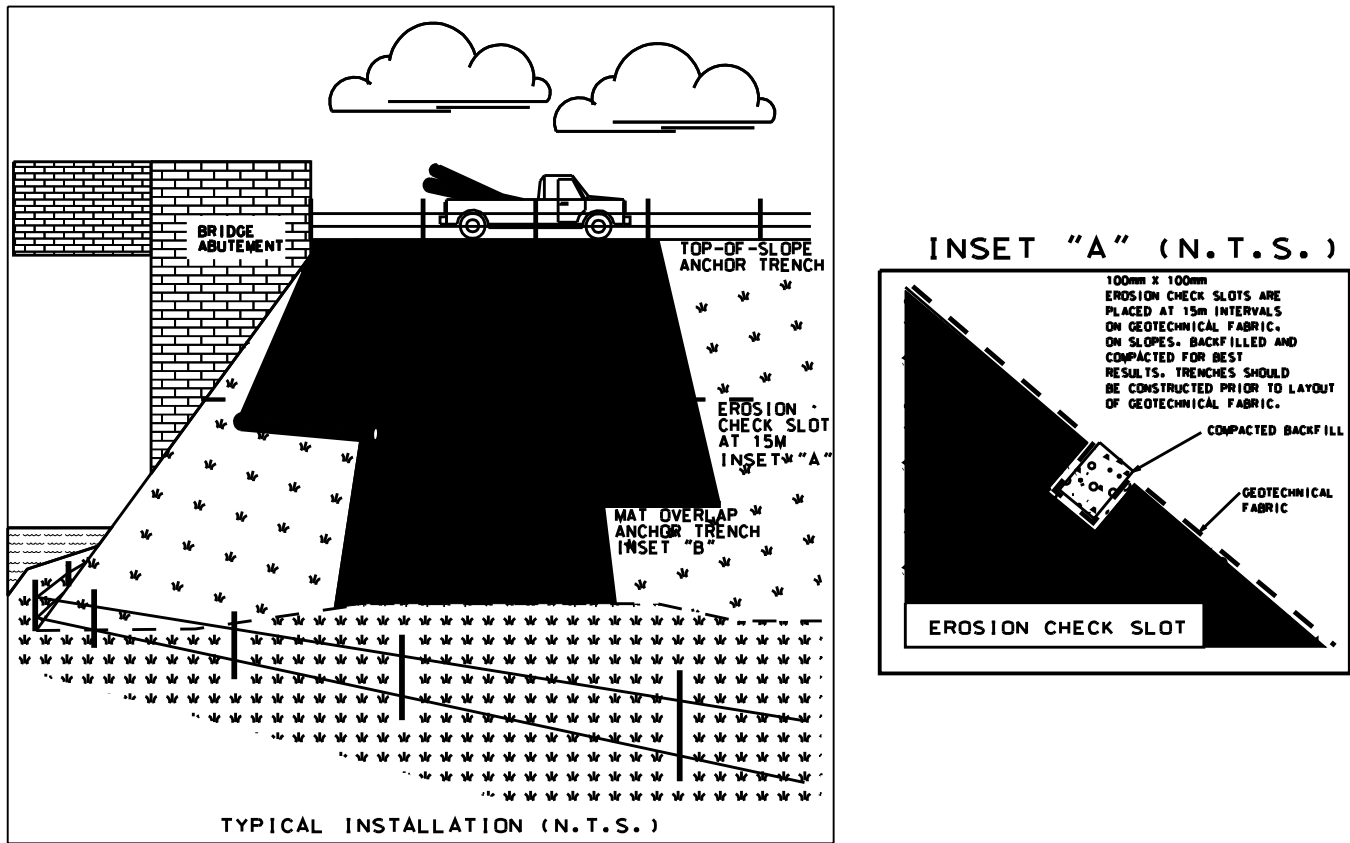

Note: Any water that may accumulate under the fabric must be prevented from moving downward with sufficient velocity to cause erosion

FIGURE 807-01 APPLICATION OF EROSION CONTROL MATS

REVISED 2001

GENERAL PROVISIONS AND CONTRACT SPECIFICATIONS  
FOR HIGHWAY CONSTRUCTION  
DEPARTMENT OF TRANSPORTATION AND PUBLIC WORKS

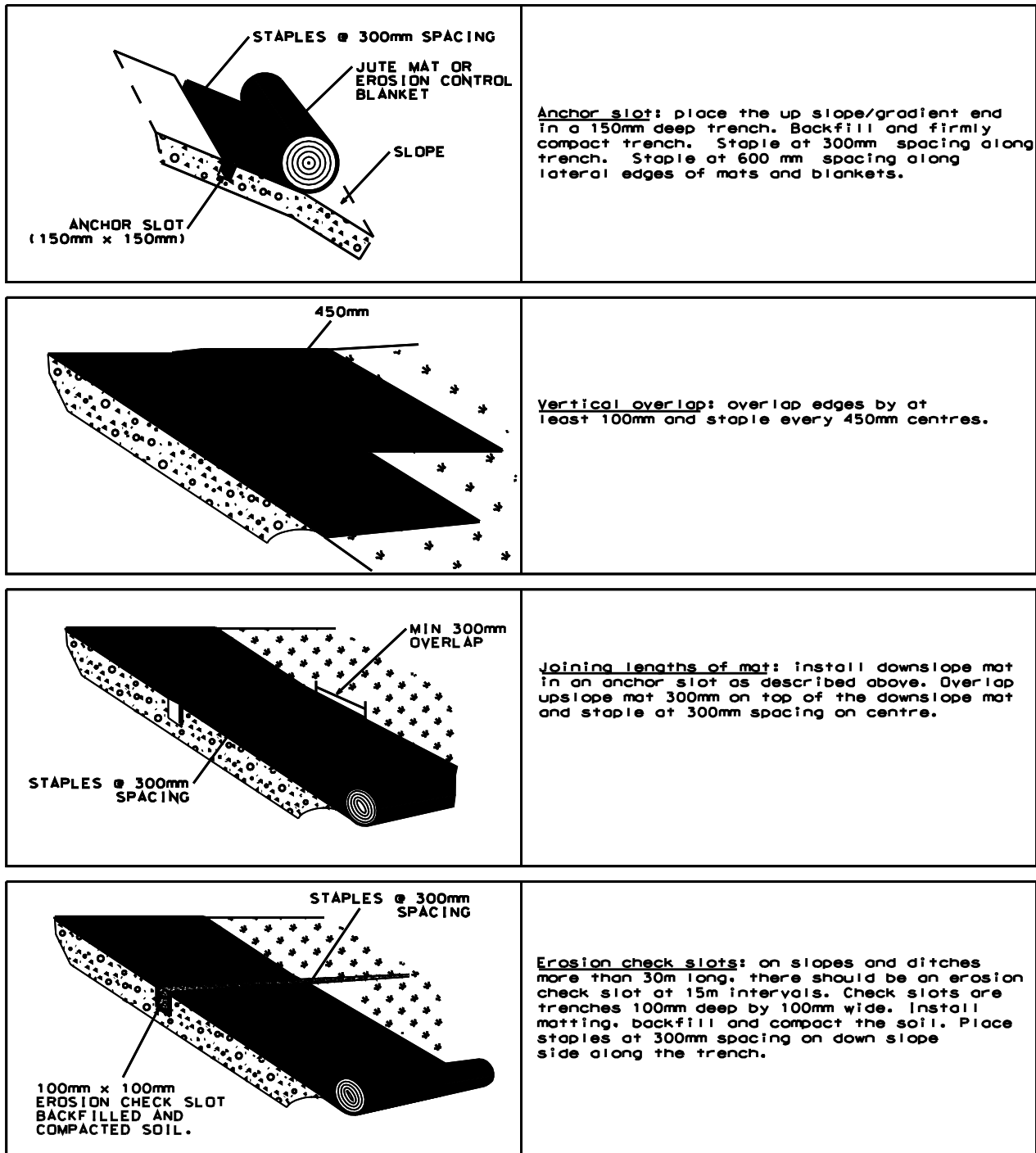

PERSPECTIVE VIEWS (N.T.S)

Note: Follow suppliers installation requirements if more stringent than those identified above.

**FIGURE 807-02 EROSION CONTROL MAT INSTALLATION DETAILS**

**REVISED 2001**



**GENERAL PROVISIONS AND CONTRACT SPECIFICATIONS  
FOR HIGHWAY CONSTRUCTION**

DEPARTMENT OF TRANSPORTATION AND PUBLIC WORKS

---

**SEDIMENT TRAPS**

**808**

808.01 Description

Work under this Section consists of the construction of a temporary sediment trap/pond, by building an earthen embankment with a stone outlet, to detain silt-laden run-off from small disturbed areas (generally less than 2 ha) long enough to allow the majority of sediment to settle. These sediment traps receive concentrated runoff flows and are commonly installed in newly constructed road ditches at the down gradient point of the ditch work or immediately adjacent to this point of the ditch, to function as a last location for sediment settling prior to release of the runoff water.

808.02 Material

The random rip rap for the stone outlet shall be Class R-5 in accordance with Section 213.

The geotechnical fabric shall have the minimum specifications as shown in Table 808-1.

**Table 808-1 Requirements for Geotechnical Fabric**

<b>Property</b>	<b>Min.</b>
Non-Woven Tensile Strength (N)	690
Tear Strength (N)	310
Equivalent Open Size - EOS ( $\mu\text{m}$ )	50-150
Elongation at Break (%)	70-100

808.03 Construction

Sediment traps should be an initial installation at a work site, constructed prior to grubbing the site. Sediment traps should not be located within 20 metres of an inlet or an outlet of a cross road drainage structure.

The sediment trap should be designed to ensure that the ponding within the structure achieves the purpose of providing adequate opportunity for suspended solids in the runoff water to settle.

The trap length should be at least twice the average width, and the trap depth should be approximately 1 m to provide adequate sediment retention capacity and to lessen the frequency of clean-out. The trap depth can be increased should a greater retention volume be desired.

The trap shall have earthen embankments that will form an impoundment area. The area under the embankments shall be cleared, grubbed and stripped of any vegetation or roots before clean, excavated fill is placed and compacted in 150 mm layers. The embankment side slopes should be no steeper than 1:1. The top and outside slopes of the earthen embankments shall be hydro seeded or seeded and covered with jute mat immediately after installation.

**GENERAL PROVISIONS AND CONTRACT SPECIFICATIONS  
FOR HIGHWAY CONSTRUCTION**

DEPARTMENT OF TRANSPORTATION AND PUBLIC WORKS

---

**SEDIMENT TRAPS**

**808**

Immediately beyond the downstream end of the stone outlet, an apron area shall be excavated to a depth of approximately 300 mm (below the bottom of impoundment elevation) to receive the overflow water and to minimize associated erosion.

Following preparation of the impoundment embankments and the apron area, the stone outlet area shall be prepared. The outlet shall be located at the downstream end of the trap, with its main spillway elevation approximately 300 mm below the top of the impoundment embankments to ensure that discharge occurs through the spillway. The spillway shall have a minimum width of 600 mm in accordance with Figure 808-1.

Once the subgrade for the base and side slopes of the outlet as well as the apron are brought to grade, the geotechnical fabric shall be placed on these prepared earthen surfaces. The edges of the fabric will overlap onto the earthen embankment areas at least 100 mm. At the upstream side of the outlet, the fabric shall be securely toed-in to the earthen base of the impoundment. At the downstream side of the outlet, the fabric shall extend into the apron area and be securely toed-in to its earthen base material.

The riprap for the spillway core will then be placed on the fabric, being careful not to damage the fabric. The top of the spillway shall be 300 mm lower than the adjacent embankments, and the spillway core will extend across the full width of the outlet.

The core riprap then needs to be wrapped with geotechnical fabric. At the upstream side of the outlet, the fabric shall again extend down to the impoundment base and be securely toed-in to the earthen base of the impoundment. This will avoid undermining at the upstream side of the outlet. The fabric will wrap overtop of the spillway riprap core, down the downstream side of the core, and will extend into the apron and be securely toed-in to its earthen base material. This fabric will extend at least as far into the apron as the previously installed fabric so that runoff flows overtop of the fabric and undermining of the apron is avoided.

Finally, place remaining riprap on the side slopes of the outlet and on the downstream side of the spillway (covering the fabric in these locations), and in the apron area (including overtop of the fabric in the apron).

**808.04 Maintenance**

The Contractor shall inspect regularly and after rainfalls of 5 mm or more accumulation and repair any damaged areas.

Sediment shall be removed and the trap restored to its original dimensions when the trap is  $\frac{2}{3}$  full of sediment in accordance with Section 810.

The Contractor shall dispose of sediment at a location approved by the Engineer.

The Contractor shall remove the sediment trap after the area has stabilized and the trap is no longer needed for siltation control. Then, the site should be levelled and revegetated.

The Engineer may require that some or all sediment traps be maintained after substantial completion of the work.

**GENERAL PROVISIONS AND CONTRACT SPECIFICATIONS  
FOR HIGHWAY CONSTRUCTION**

DEPARTMENT OF TRANSPORTATION AND PUBLIC WORKS

---

**SEDIMENT TRAPS**

**808**

808.05 Measurement of Payment

Measurement for payment under this Section shall be the number of sediment traps constructed and maintained.

808.06 Basis of Payment

Payment under this Section shall be at the unit bid price per sediment trap and this price shall be full compensation for the excavation, embankment construction, supply and placement of filter fabric, supply and placement of riprap, labour and incidentals necessary to build, install, maintain, dispose of all surplus materials including sediments, and level and revegetate the site to a condition acceptable to the Engineer.

Maintenance and decommissioning that is required after substantial completion of the site work shall be paid for under Section 810.

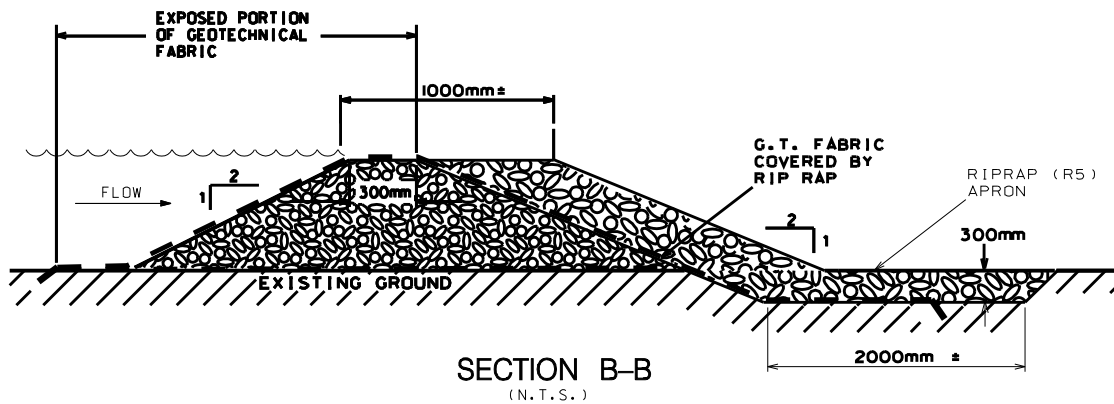
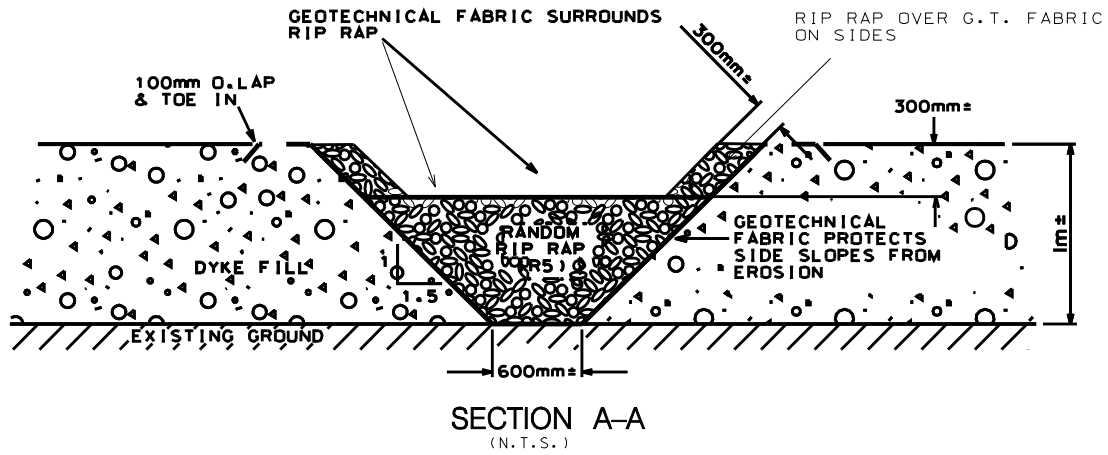
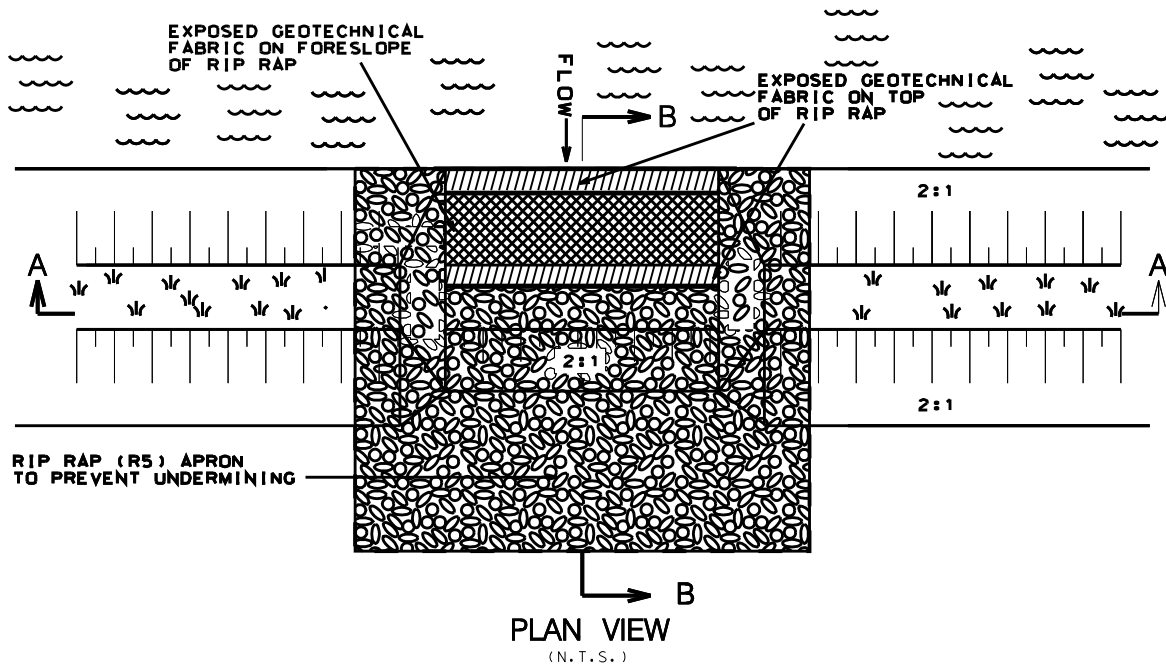

**FIGURE 808-01 SEDIMENT TRAP**  
 REVISED 2001

**GENERAL PROVISIONS AND CONTRACT SPECIFICATIONS  
FOR HIGHWAY CONSTRUCTION**

DEPARTMENT OF TRANSPORTATION AND PUBLIC WORKS

---

**SODDING**

**809**

---

809.01 Description

This Section specifies the requirements for the supply, transportation and placement of sod behind curbs, as indicted on Drawings, or for the maintenance of sodded areas.

809.02 Source Quality Control

Obtain Engineer's approval of sod at the source of supply.

When the proposed source of sod is approved, use no other source without written notification.

809.03 Delivery and Storage

Schedule deliveries in order to keep storage at the work site to a minimum without causing delays.

Deliver, unload and store sod on pallets.

Deliver sod to the site within 24 hours of being lifted and lay sod within 36 hours of being lifted.

Do not deliver small, irregular or broken pieces of sod.

During wet weather allow sod to dry sufficiently to prevent tearing during lifting and handling.

During dry weather protect sod from drying and water sod as necessary to ensure its vitality and prevent dropping of soil in handling. Dry sod will be rejected.

809.04 Scheduling

Schedule sod laying to coincide with the topsoil operations of Section 212.

809.05 Material

Nursery sod shall provide sod with good cover of living or growing grass including grass that is seasonally dormant during the cold or dry seasons and that is capable of renewing growth after the dormant period. Cut sod from living, thickly matted turf, relatively free from weeds or other undesirable foreign plants, stones or roots.

Topsoil shall be in accordance with Section 212.

Fertilizer shall be 6-12-12 grade, uniform in composition, free flowing and suitable for application with approved equipment. The fertilizer shall be supplied in unopened waterproof bags fully labelled. Fertilizer other than the standard for grades specified must be approved by the Engineer and must not have less than the minimum requirements for the grades specified. At least 50% of the fertilizer's components are to be derived from organic sources.

Lime shall be ground agricultural or dolomitic limestone, containing not less than 85% total carbonates. It shall be ground so that 100% will pass a 10-mesh screen and 50% will pass a 100-mesh screen. Lime may be substituted for ground agricultural limestone at the discretion of the Engineer.

**GENERAL PROVISIONS AND CONTRACT SPECIFICATIONS  
FOR HIGHWAY CONSTRUCTION**

DEPARTMENT OF TRANSPORTATION AND PUBLIC WORKS

---

**SODDING**

**809**

---

Water shall be potable.

809.06 Construction Method

809.06.01 Spreading Topsoil

Do not spread topsoil until Engineer has inspected subgrade.

Apply 100 mm topsoil to areas to be sodded.

Spread topsoil with adequate moisture in uniform layers during dry weather over approved, dry, unfrozen subgrade, where sodding is indicated.

Keep topsoil 50 mm below finished grade for sodded areas.

Remove stones, roots, grass, weeds, construction materials, debris and foreign, non-organic objects from topsoil.

Roll topsoil with 45 kg roller, 900 mm wide, to compact and retain surface.

809.06.02 Soil Additives

Apply lime, or other soil additives at a rate determined from the soil sample.

Mix soil additives well into full depth of the topsoil by cultivating or rotor-tilling prior to the application of fertilizer.

809.06.03 Fertilizer

Apply fertilizer at least one week after lime application and at least six (6) days before sodding.

Spread fertilizer with mechanical spreaders over entire area at manufacturer's recommended rate of application.

Mix fertilizer thoroughly into upper 50 mm of soil.

809.06.04 Laying of Sod

Obtain approval of topsoil grade and depth before starting sodding.

Lay sod during growing season. Sodding during dry summer period, at freezing temperatures or over frozen soil is not acceptable.

Lay sod in rows, perpendicular to slope, smooth and even with adjoining areas and with staggered joints. Butt sections closely without overlapping or leaving gaps between sections. Cut out irregular or thin sections with a sharp knife.

Provide close contact between sod and soil by means of light rolling. Heavy rolling to correct grade irregularities is not permitted.

Water immediately after sod laying to obtain moisture penetration in top 100 mm of topsoil.

**GENERAL PROVISIONS AND CONTRACT SPECIFICATIONS  
FOR HIGHWAY CONSTRUCTION**

DEPARTMENT OF TRANSPORTATION AND PUBLIC WORKS

---

**SODDING**

**809**

Provide adequate protection of sodded areas against erosion and mechanical damage. Remove protection after lawn areas have been accepted.

809.07 Maintenance

Take care and maintain all sodded areas until final acceptance of the work.

Water all sodded areas throughout the twelve (12) month maintenance period.

Repair damaged areas to the approval of the Engineer.

Mow sodded areas an average of three (3) cuts per month during the entire growing season.

Cut grass to height of 40 mm. Use equipment that is in good working order with sharp cutting blades.

Remove grass clippings from sodded areas. Hand trim or use trimmer for grass adjacent to structures, curbs, trees, fences or where necessary.

Ensure clippings do not get on to hard surfaces.

Apply weed killer in accordance with manufacturer's instructions if broadleaf weeds start to develop.

809.08 Acceptance

Grassed areas will be accepted by the Engineer at the end of the maintenance period provided that:

- Grassed areas are properly established
- Turf is free of bare and dead spots and without weeds

Areas grassed in the fall will be accepted the following spring one (1) month after the start of the growing season provided the conditions specified are fulfilled.

809.09 Method of Measurement

Measurement for payment under this Section shall be the number of square metres of sod placed.

809.10 Basis of Payment

Payment for sodding shall be at the unit bid price per square metre and this price shall be full compensation for the supply and placement of nursery sod, soil additives, watering, maintenance and incidentals necessary to complete the work.

Topsoil shall be paid according to Section 212.

**GENERAL PROVISIONS AND CONTRACT SPECIFICATIONS  
FOR HIGHWAY CONSTRUCTION**

DEPARTMENT OF TRANSPORTATION AND PUBLIC WORKS

---

**MAINTENANCE AND DECOMMISSIONING OF SEDIMENT CONTROL STRUCTURES 810**

810.01 Description

This work shall consist of the maintenance and decommissioning of check dams, silt fences, sediment traps, and straw bale barriers, and the removal of sediment therefrom after substantial completion of the work. The work requires prior approval by the Engineer

All work under this section will be considered as extra work.

810.02 Monitoring

To ensure that erosion and sediment control measures are in effective working order, their condition must be monitored prior to forecasts of storm events, during a storm event and following a storm event.

810.03 Maintenance

Sediment that is accumulated by check dams and settlement traps shall be removed in a manner that avoids escape of silt to the downstream side of the structure so as to avoid damage to the control structure.

Accumulated sediment shall be removed when it reaches a depth of one-half the effective height of the control structure.

Accumulated sediment shall be removed immediately prior to the removal of the control measures.

The sediment removed shall be disposed of as per the Engineer's instructions.

For all control structures accumulated sediment shall be removed as necessary to perform repairs.

Maintenance of the sediment control structure shall comply with the appropriate section.

810.04 Decommissioning

Decommissioning of the sediment control structure shall comply with the appropriate section.

810.05 Method of Measurement

Measurement for payment under this section shall be the time spent for the extra work as directed by the Engineer.

810.06 Basis of Payment

Payment for extra work will be full compensation for all labour, equipment and materials required to do the work.



**GENERAL PROVISIONS AND CONTRACT SPECIFICATIONS  
FOR HIGHWAY CONSTRUCTION**

DEPARTMENT OF TRANSPORTATION AND PUBLIC WORKS

---

**STRAW BALE BARRIER**

**811**

811.01 Description

This work shall consist of the installation and maintenance of straw bales (or hay bales as directed by the Engineer) to control sediment-laden runoff and prevent sediments from leaving the construction site.

They shall be installed as perimeter containment for temporary material stockpiles, as reinforcement for perimeter silt fencing, or down gradient of disturbed areas where erosion occurs in the form of sheet or rill erosion.

811.02 Material and Construction Method

All materials are to be supplied by the contractor.

The Contractor shall place the bales on their sides and tightly together so that the twine is not in contact with the ground.

Bales shall be secured by driving two sturdy wooden or steel stakes through each bale, deep enough to anchor them securely. The Contractor shall drive the first stake in each bale toward the previously laid bale to force the bales together.

The Contractor shall wedge loose straw between any cracks or other openings and scatter loose straw over the soil on the uphill side of the barrier. Subsequent movement of the loose straw tends to seal any undetected openings in the barrier.

Straw bale barriers shall be installed as shown on Figure 811-1.

811.03 Maintenance

The Contractor shall comply with the following procedure:

Inspect regularly and after rainfalls of 5 mm or more accumulation and repair as required. Undercutting and end flow are a common problem.

Clean out accumulated sediment regularly and before it reaches one half the height of the barrier.

Dispose of sediment at an approved location.

If weather forecasts indicate that a significant rainfall may occur, it is recommended that barriers be checked and cleaned out prior to the rainfall as a preventative measure.

Bales should be replaced if they become clogged with sediment.

Remove structures after the area has stabilized, level and seed areas disturbed during removal, and inspect regularly and repair if / as required until the area has stabilized.

The Engineer may require that some or all straw bale barriers be maintained after substantial completion of the work.

**GENERAL PROVISIONS AND CONTRACT SPECIFICATIONS  
FOR HIGHWAY CONSTRUCTION**

DEPARTMENT OF TRANSPORTATION AND PUBLIC WORKS

---

**STRAW BALE BARRIER**

**811**

---

811.04 Method of Measurement

Measurement for payment under this Section shall be the number of straw bales that are installed and maintained as per this specification.

811.05 Basis of Payment

Payment for straw bale barriers shall be at the unit bid price per straw bale and this price shall be full compensation for the supply and installation of the bale, stakes and loose straw, labour, equipment, tools and incidentals necessary to install, maintain, decommission the barrier including disposal of all surplus materials and accumulated sediments, and site reinstatement to a condition acceptable to the Engineer.

Maintenance and decommissioning that is required after substantial completion of the site work shall be paid for under Section 810.

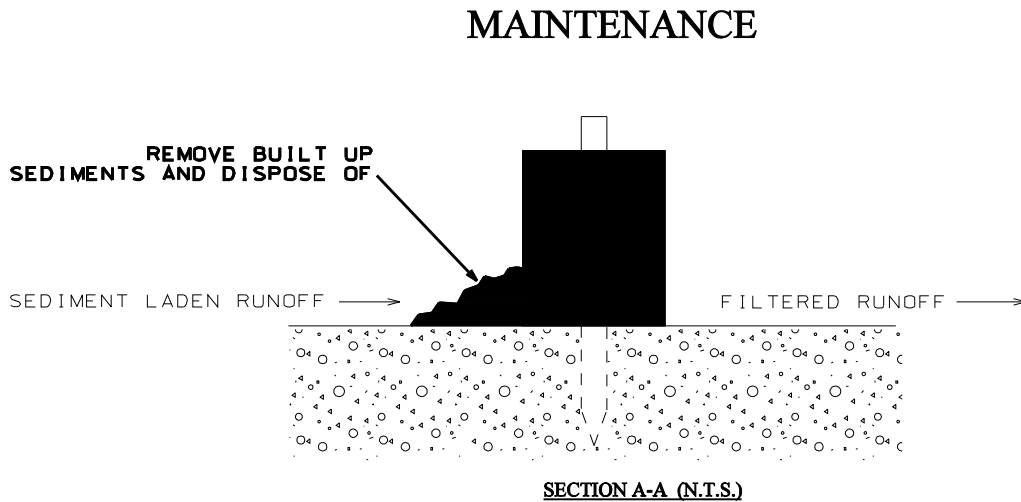
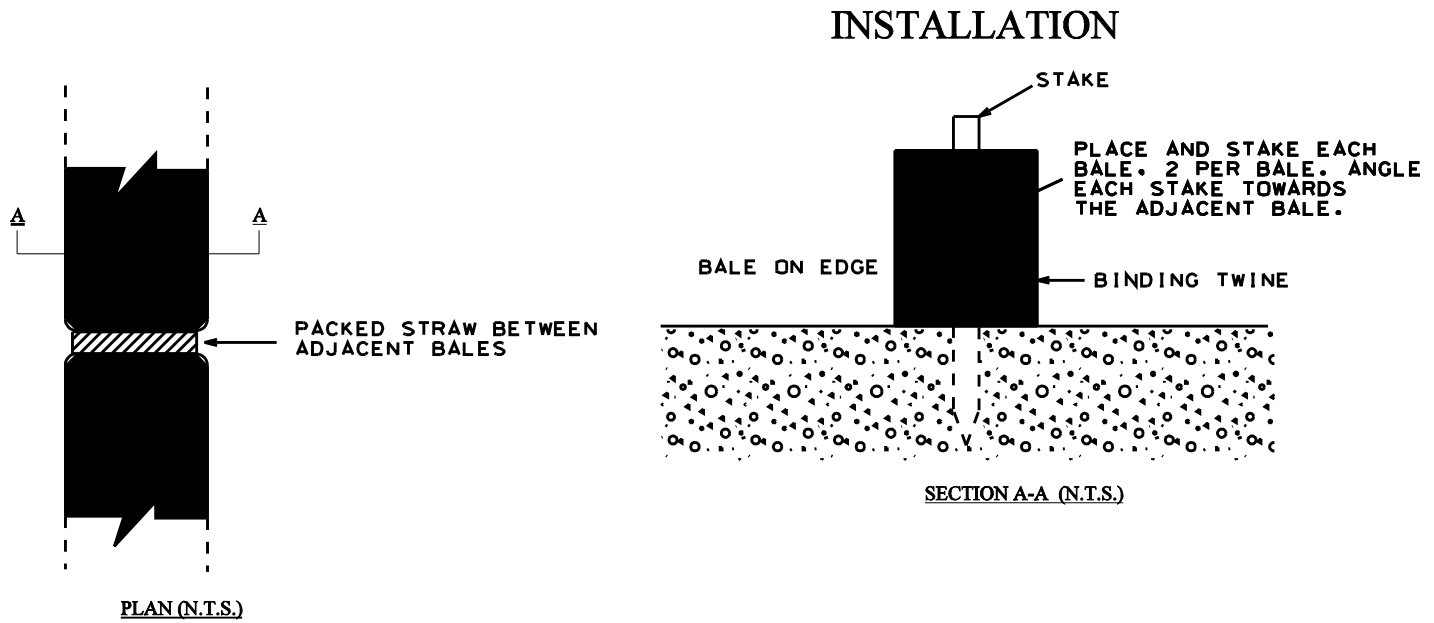

**FIGURE 811-01 STRAW BALE BARRIER**

**REVISED 2001**

**GENERAL PROVISIONS AND CONTRACT SPECIFICATIONS  
FOR HIGHWAY CONSTRUCTION**

DEPARTMENT OF TRANSPORTATION AND PUBLIC WORKS

---

**COMPOST**

**812**

---

812.01 Description

This item consists of the supply and application of approved compost material as shown on the plans or as directed by the Engineer.

This specification refers to standards, specifications or publications noted below. All reference standards shall be current issue or latest revision at the first date of tender advertisement.

- CCME Guidelines for Compost Quality
- ADI International (PEI) Inc. Compost from Organic-based Waste Resources Brochure 1-.3-.3
- IWMC Compost from Organic-based Waste Resources Brochure 1-.4-.5
- Canada Fertilizers Act and Regulations

812.02 Material

The compost material shall be supplied by the Contractor, and shall be an organic substance produced from the aerobic decomposition of organic matter. The compost material shall not contain any visible refuse material nor any material toxic to plant establishment or growth. The composted material may be derived from, but not limited to, leaves, yard trimmings, food scraps, food processing residues, manure and other agricultural residues, bark and other forest residues, soiled or un-recycled paper and biosolids.

Compost materials shall meet all applicable provincial and federal regulations and guidelines for compost production (see above reference materials). Compost material shall meet the CCME Guidelines for Category A. Compost material shall meet the physical requirements shown in Table 1 or meet requirements designated by the Engineer.

812.02.01 Submissions and Design Requirements

Prior to delivery of compost to the site, the Contractor shall provide the Engineer with the following information:

- Correspondence verifying that the compost meets CCME Guidelines for Category A Compost
- Correspondence verifying that the compost material meets the physical requirements in Table 1.

The Engineer may require the Contractor to provide a sample of the compost for confirmatory purposes.

**GENERAL PROVISIONS AND CONTRACT SPECIFICATIONS  
FOR HIGHWAY CONSTRUCTION**

DEPARTMENT OF TRANSPORTATION AND PUBLIC WORKS

**COMPOST**

**812**

**Table 1 (as received basis)**

<b>Compost for Manufactured Topsoil</b>	<b>Erosion Control Compost</b>	<b>General Use Compost</b>
Organic Matter Content: >30% dry mass	Organic Matter Content: 40-60% dry mass	Organic Matter Content: 40-60% dry mass
Moisture Content: 40-60%	Moisture Content: 40-60%	Moisture Content: 40-60%
Particle Size: 100% passing 25 mm sieve	Particle Size: 100% passing 80 mm and approx. 70% passing 25 mm sieve	Particle Size: 100% passing 25 mm and approx. 70% passing 10 mm sieve
Soluble Salts: 5.0 max. dS/m	Soluble Salts: 5.0 max. dS/m	Soluble Salts: 5.0 max. dS/m
pH: 5.0 - 8.5	pH: 5.0 - 8.5	pH: 5.0 - 8.5

**812.03 Construction Method**

After the designated areas have been graded according to the lines and grades approved by the Engineer, compost of the specified type shall be placed according to the following descriptions. Compost materials shall be loose and friable and be free of dust at the time of application. No compost materials shall be stored on site within 30 m of a watercourse.

**812.03.01 Compost Manufactured Topsoil**

Compost manufactured topsoil shall consist of soil material amended with 20 - 30% compost by volume. The soil material shall be free from trash, branches and other objectionable materials, and shall be approved by the Engineer prior to beginning the mixing process.

**Blended On-site**

Compost shall be evenly spread in a uniform layer over the previously prepared slope and thoroughly mixed to the depths shown on the plans or as directed by the Engineer.

**Pre-blended**

Topsoil manufactured off-site shall be spread over the prepared slope in a uniform layer to a depth of 10 - 20 cm. The topsoil shall be free of objectionable materials.

**812.03.02 Erosion Control Compost**

Compost materials shall be spread evenly over the prepared subgrade or slopes to form a uniform layer of a thickness of 50 - 75 mm or as shown on the plans. Compost shall not be used for erosion control on slopes steeper than 2:1.

**GENERAL PROVISIONS AND CONTRACT SPECIFICATIONS  
FOR HIGHWAY CONSTRUCTION**

DEPARTMENT OF TRANSPORTATION AND PUBLIC WORKS

---

**COMPOST**

**812**

---

812.03.03     General Use Compost

General use compost shall be applied as a top dressing over established areas of turf, grass or other ground cover to the depth specified on the plans or as directed by the Engineer.

812.04   Method of Measurement

Measurement for compost shall be the area in square metres where compost manufactured topsoil (both blended on-site and pre-blended), erosion control compost, general use compost has been acceptably applied and in place, measured along the slope of the ground.

812.05   Basis of Payment

812.05.01     Compost manufactured topsoil

812.05.02     Erosion control compost

812.05.03     General use compost

Payment at the contract unit price for the above tender item(s) shall be full compensation for all labour, equipment and material necessary to perform the work, and shall include supply and transport.

Where soil material used in the production of Compost Manufactured Topsoil originates from off-site locations, payment for the soil material shall be consistent with terms described in Sections 205.04 and 206.05.

Slope preparation prior to use of compost materials and removal of objectionable materials will not be measured for payment, but shall be considered as incidental to the bid items under which the excavation or embankment construction of such areas was carried out.

If hydroseeding is required, payment for hydroseeding will be made as per Section 803.

**GENERAL PROVISIONS AND CONTRACT SPECIFICATIONS  
FOR HIGHWAY CONSTRUCTION**

DEPARTMENT OF TRANSPORTATION AND PUBLIC WORKS

---

**GABIONS**

**813**

---

813.01 Description

This Item consists of the supply and installation of gabion baskets fabricated from wire mesh and filled with rock.

813.02 Materials

All materials shall be supplied by the Contractor.

Gabion baskets shall be fabricated of galvanized wire mesh.

Fasteners to secure the baskets shall be supplied in a material compatible with the material type and properties of the basket.

Rocks used in the construction of gabions shall be clean, hard, sound and durable, with the least dimension of any rock equal to or greater than one and one-half times the mesh size, and shall not exceed 300 mm in greatest dimension.

Rock used for basket fill material, when tested by Los Angeles Abrasion test method in accordance with ASTM C131 and/or C535, shall have an abrasion loss not greater than 40%.

Rocks shall be of a size that at least two layers of overlapping rock are required to fill the gabion.

Geotextile shall be supplied in accordance Section 218, Type N1.

Gabion baskets shall conform to the following minimum standards:

Factory fabricated so that the sides, ends, lid and internal diaphragms can be readily assembled at the work area into rectangular baskets of the sizes indicated in the Contract Documents.

When the length exceeds horizontal width, diaphragms of the same mesh as the gabion basket walls shall be used to divide the basket into equal cells of a length not in excess of the horizontal width.

Wire mesh shall be a uniform regular pattern, with a maximum nominal opening size of 80 by 100 mm, and fabricated to be non-ravelling.

Selvedge edges of the mesh shall be securely fastened together so that the joints, which are formed, are as strong as the body of the mesh.

Hot dip galvanized wire shall have a minimum coverage of 260 grams/square metre and shall conform to ASTM Tests: A641, A90, and A764.

Wire shall be dimensioned, as a minimum, as indicated in Table 813.1

The Contractor shall supply free draining backfill behind the gabion Structure.

**GENERAL PROVISIONS AND CONTRACT SPECIFICATIONS  
FOR HIGHWAY CONSTRUCTION**

DEPARTMENT OF TRANSPORTATION AND PUBLIC WORKS

---

**GABIONS**

**813**

---

**Table 813.1  
Minimum Twisted Galvanized Wire Dimensions**

<b>Application</b>	<b>Diameter</b>
Mesh	2.95 mm
Selvages	3.80 mm
Binding	2.20 mm
Interlocking Wire Fasteners	3.17 mm

**813.03 Submittals**

The Contractor shall submit, in advance of the work, a mill certificate for the gabion materials to be supplied.

The Contractor shall submit, upon request, the manufacturer's recommended procedures for installation and instructions for handling of the selected gabion.

The Contractor shall notify the Engineer, in writing, for approval of the source of supply of rock, at least 14 days in advance of obtaining material from the source proposed.

Submittals are required in accordance with any cross-referenced Item forming part of this Item.

**813.04 Construction**

The Contractor shall carry out the work as indicated in the Contract Documents and/or as specifically directed by the Engineer.

The Contractor shall prepare the grades and slopes of the underlying material as shown on the Plans or as directed by the Engineer.

The Contractor shall place the gabions on a prepared compacted soil foundation grade and shall assemble the gabions according to the manufacturer's instructions and recommendations.

The gabion baskets in any row shall be filled in stages to minimize void spaces and so that local deformations are avoided.

The rock for the exposed rock face(s) of the gabion basket shall be hand placed to ensure proper alignment and a neat, compact, square appearance.

Bulges in the gabions shall not exceed 40 mm at the most extreme point measured in any cell.

The geotextile shall be placed in accordance with Section 218.

**813.05 Measurement for Payment**



**GENERAL PROVISIONS AND CONTRACT SPECIFICATIONS  
FOR HIGHWAY CONSTRUCTION**

DEPARTMENT OF TRANSPORTATION AND PUBLIC WORKS

---

**GABIONS**

**813**

The quantity to be measured under this Section shall be the volume in cubic metres of gabions supplied and installed in accordance with this Item.

Measurement additional backfill material and geotextile will be made in accordance with the respective Specification Section.

813.06 Basis of Payment

Payment for work under this Item shall be at the unit bid price for the number of cubic metres of gabions supplied and installed and shall be full compensation for all materials, including rock, work, additional costs associated with backfill materials and incidentals necessary to complete the work unless specified otherwise in this section.

Payment for free draining backfill, additional backfill material and geotextile will be made in accordance with the respective Specification Section.

GENERAL PROVISIONS AND CONTRACT SPECIFICATIONS  
FOR HIGHWAY CONSTRUCTION

DEPARTMENT OF TRANSPORTATION AND PUBLIC WORKS

GABIONS

813

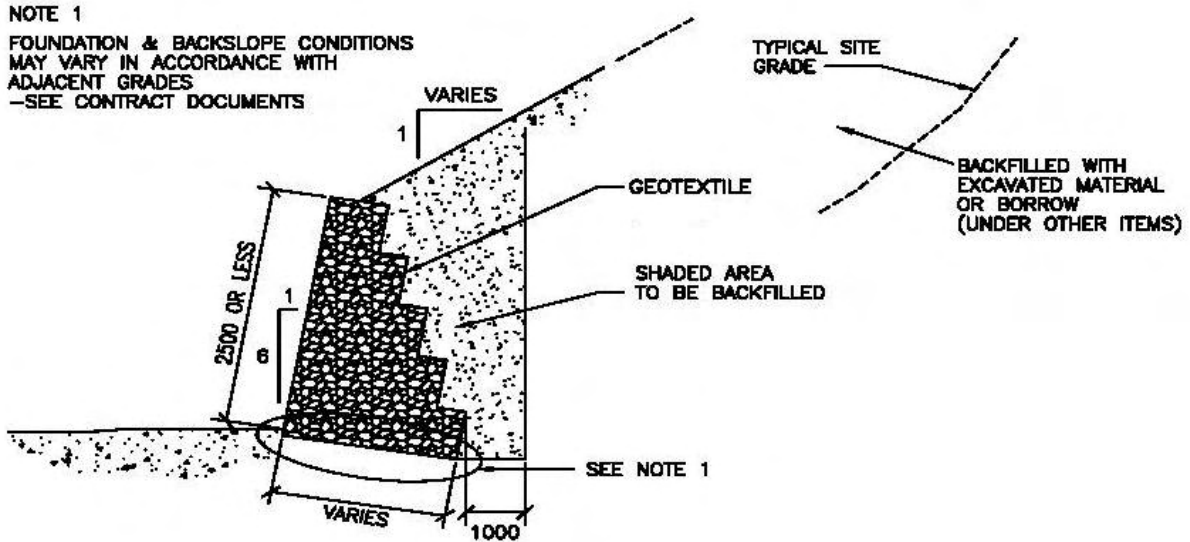

SLOPING FRONT

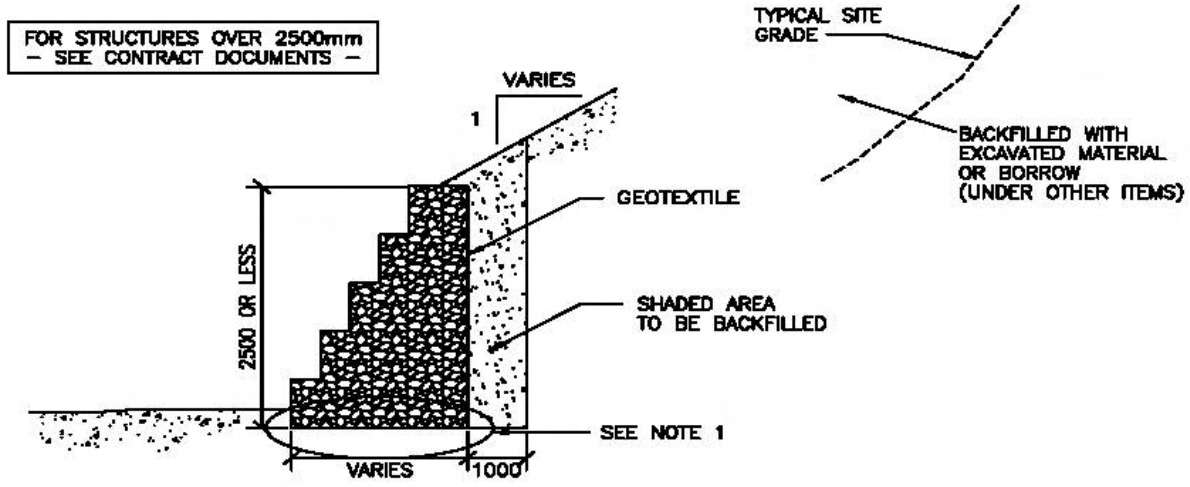

STEPPED FRONT

FIGURE 813-1 Gabion Details

**GENERAL PROVISIONS AND CONTRACT SPECIFICATIONS  
FOR HIGHWAY CONSTRUCTION**

DEPARTMENT OF TRANSPORTATION AND PUBLIC WORKS

---

**SAFETY**

**900**

- 901 Signallers
- 902 Removal of Flex Beam Guiderail
- 903 Erection of Flex Beam Guiderail
- 904 Pavement Edge Delineation
- 905 Temporary Marking
- 906 Traffic Control Devices
- 907 Vehicle Configurations and Restrictions
- 908 Traffic Control Plan
- 909 Installation of Guiderail End Treatment

**GENERAL PROVISIONS AND CONTRACT SPECIFICATIONS  
FOR HIGHWAY CONSTRUCTION**

DEPARTMENT OF TRANSPORTATION AND PUBLIC WORKS

---

**SIGNALLERS**

**901**

---

901.01 Description

This work shall consist of the provision of signallers to direct traffic safely through the work site or around detours.

901.02 Personnel

The signallers must meet the requirements of Section 50.4 of the Occupational Health and Safety Act Regulations.

901.03 Equipment

The Contractor shall ensure that all signallers on the work site are clothed and equipped as specified in Part 50 of the Occupational Health and Safety Act Regulations. All signallers working on projects must be equipped with two-way radios of a quality acceptable to the Engineer.

901.04 Methods

The Contractor shall ensure that the signallers comply with Part 50 of the Occupational Health and Safety Act Regulations when directing traffic.

901.05 Requirements

The Contractor shall ensure that signallers are at the work site and at the proper location to direct traffic as required by Part 50 of the Occupational Health and Safety Act Regulations.

901.06 Method of Measurement

The quantity to be measured for payment under this section shall be the number of hours which signallers actually control traffic.

901.07 Basis of Payment

Payment for signallers shall be at the unit price per hour set by the Department and this shall be full compensation for all labour, equipment, and incidentals to carry out the work. No compensation shall be provided to the Contractor for overtime expenses that may occur.

**GENERAL PROVISIONS AND CONTRACT SPECIFICATIONS  
FOR HIGHWAY CONSTRUCTION**

DEPARTMENT OF TRANSPORTATION AND PUBLIC WORKS

---

**REMOVAL OF FLEX BEAM GUIDERAIL**

**902**

---

902.01 Description

This work shall consist of the removal of flex beam guiderail from a roadway.

902.02 Construction Method

The Contractor shall remove existing guiderail from areas designated by the Engineer. This work shall include removal of bolts, pulling of posts and filling post holes with approved material as directed by the Engineer.

All material recovered in the dismantling operation including, but not limited to, posts, blocks, delineators and guiderail sections shall remain the property of the Department. The Contractor shall stockpile all such materials in a manner and at a location approved by the Engineer.

902.03 Method of Measurement

\_\_\_\_\_ The quantity to be measured under this Section shall be the number of linear metres of guiderail removed excluding overlapped guiderail.

902.04 Basis of Payment

Payment under this Section shall be at the unit bid price per linear metre and this price shall be full compensation for dismantling the guiderail, transporting materials to the stockpile, stockpiling materials, tools, labour, materials, equipment and incidentals necessary to carry out the work.

**GENERAL PROVISIONS AND CONTRACT SPECIFICATIONS  
FOR HIGHWAY CONSTRUCTION**

DEPARTMENT OF TRANSPORTATION AND PUBLIC WORKS

---

**ERECTION OF FLEX BEAM GUIDERAIL**

**903**

903.01 Description

This work shall consist of the erection of a flex beam guiderail.

903.02 Material

Unless otherwise specified, all materials to be used in the erection of the guiderail shall be provided by the Department in accordance with Provision 104.13.

903.03 Construction Method

The Contractor shall erect guiderails at the locations and for the length directed by the Engineer.

Erection of guiderails shall be in accordance with Figures 903-1 and 903-2.

903.04 Method of Measurement

The quantity to be measured under this Section shall be the number of linear metres of guiderail erected excluding overlapped guiderail.

903.05 Basis of Payment

Payment under this Section shall be at the unit bid price per linear metre and this price shall be full compensation for erection of the guiderail, tools, labour, equipment and incidentals necessary to complete the work.

GENERAL PROVISIONS AND CONTRACT SPECIFICATIONS  
 FOR HIGHWAY CONSTRUCTION  
 DEPARTMENT OF TRANSPORTATION AND PUBLIC WORKS

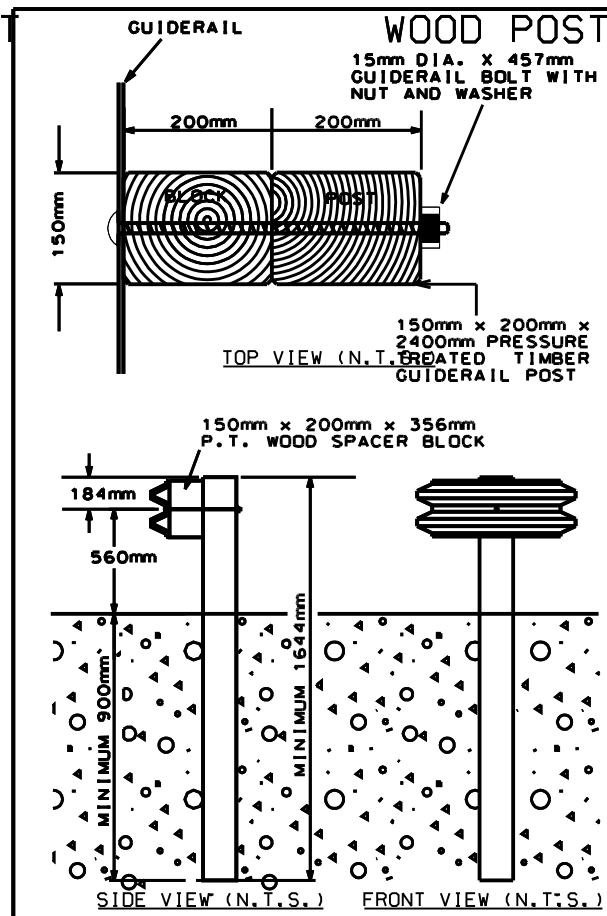
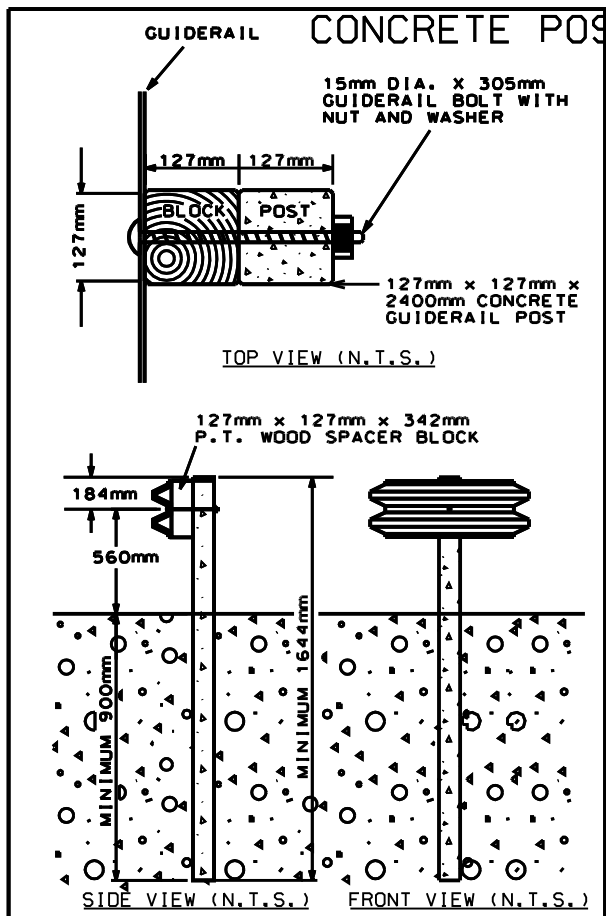
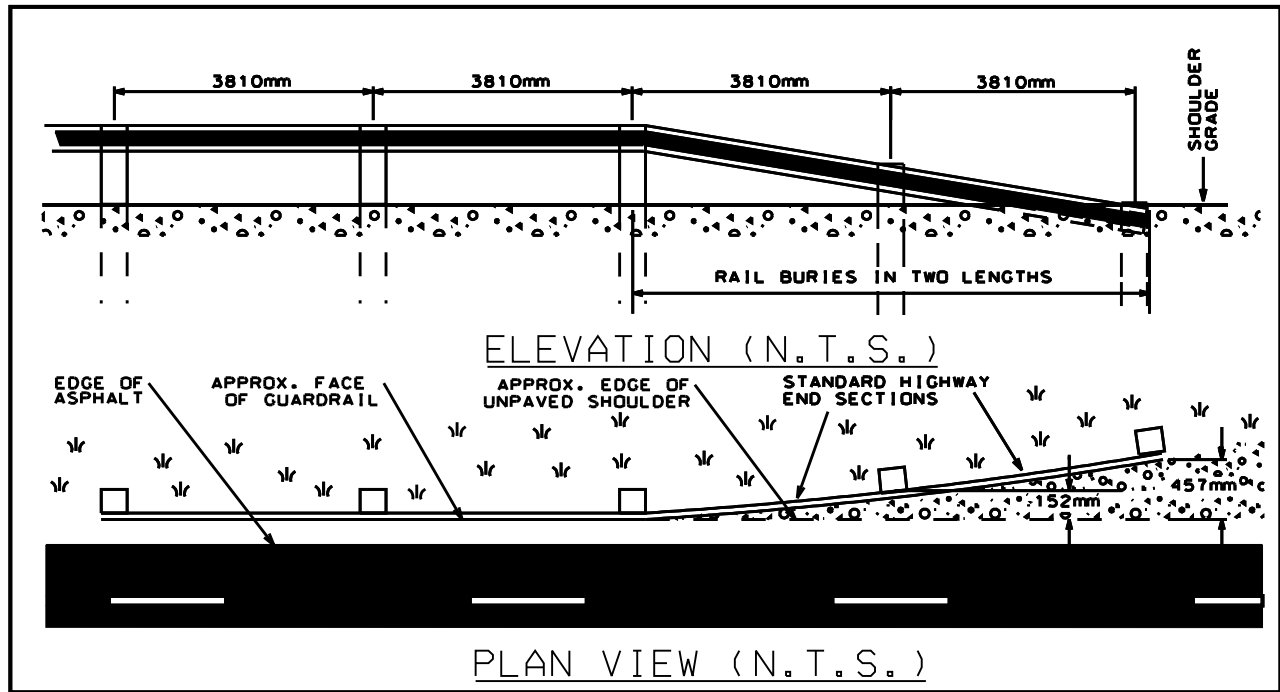

FIGURE 903-01 ERECTION OF FLEX BEAM GUIDERAIL  
 REVISED 2005

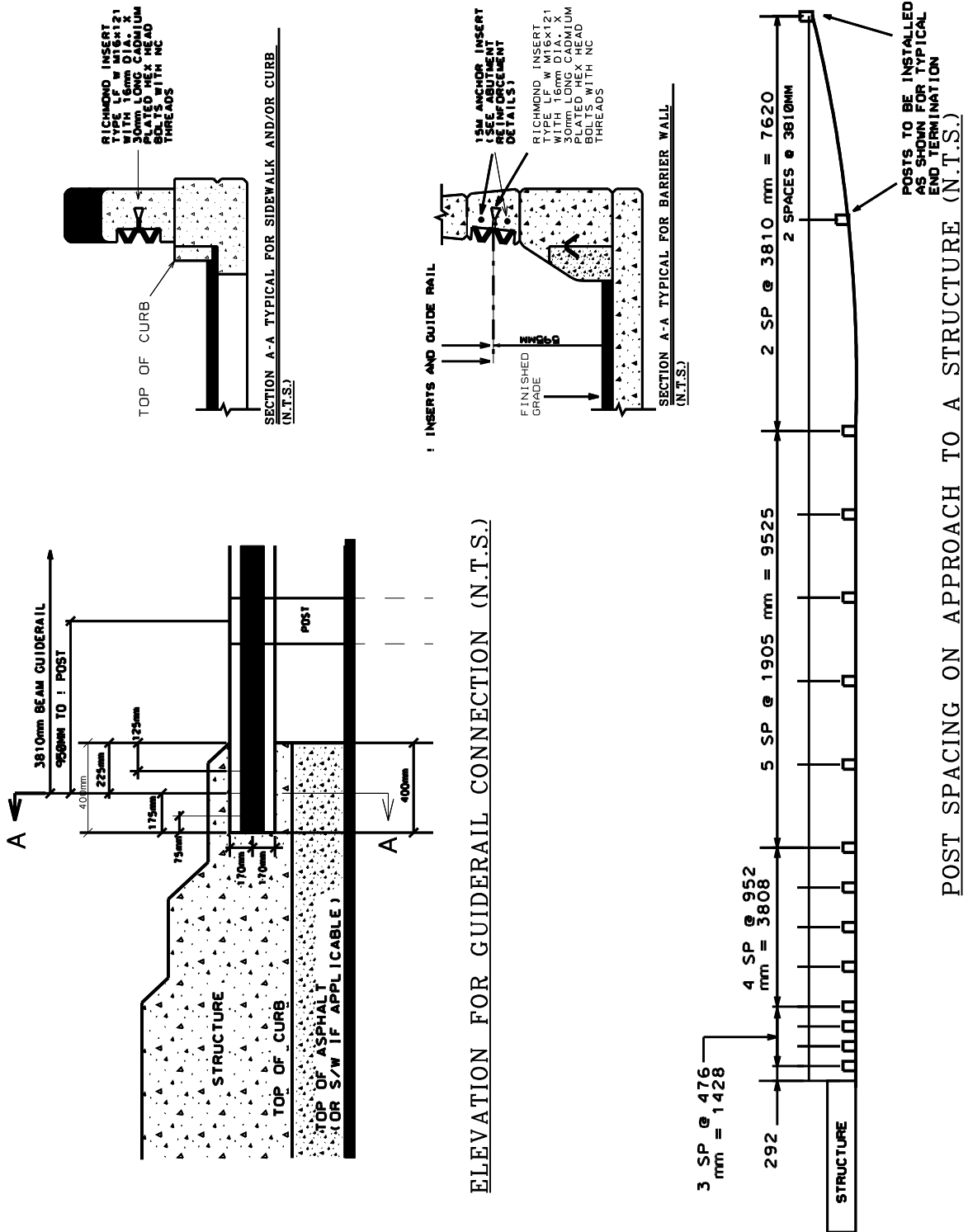

FIGURE 903-02 CONNECTION OF FLEX BEAM GUIDERAIL AT A STRUCTURE

REVISED 2006



GENERAL PROVISIONS AND CONTRACT SPECIFICATIONS  
FOR HIGHWAY CONSTRUCTION  
DEPARTMENT OF TRANSPORTATION AND PUBLIC WORKS

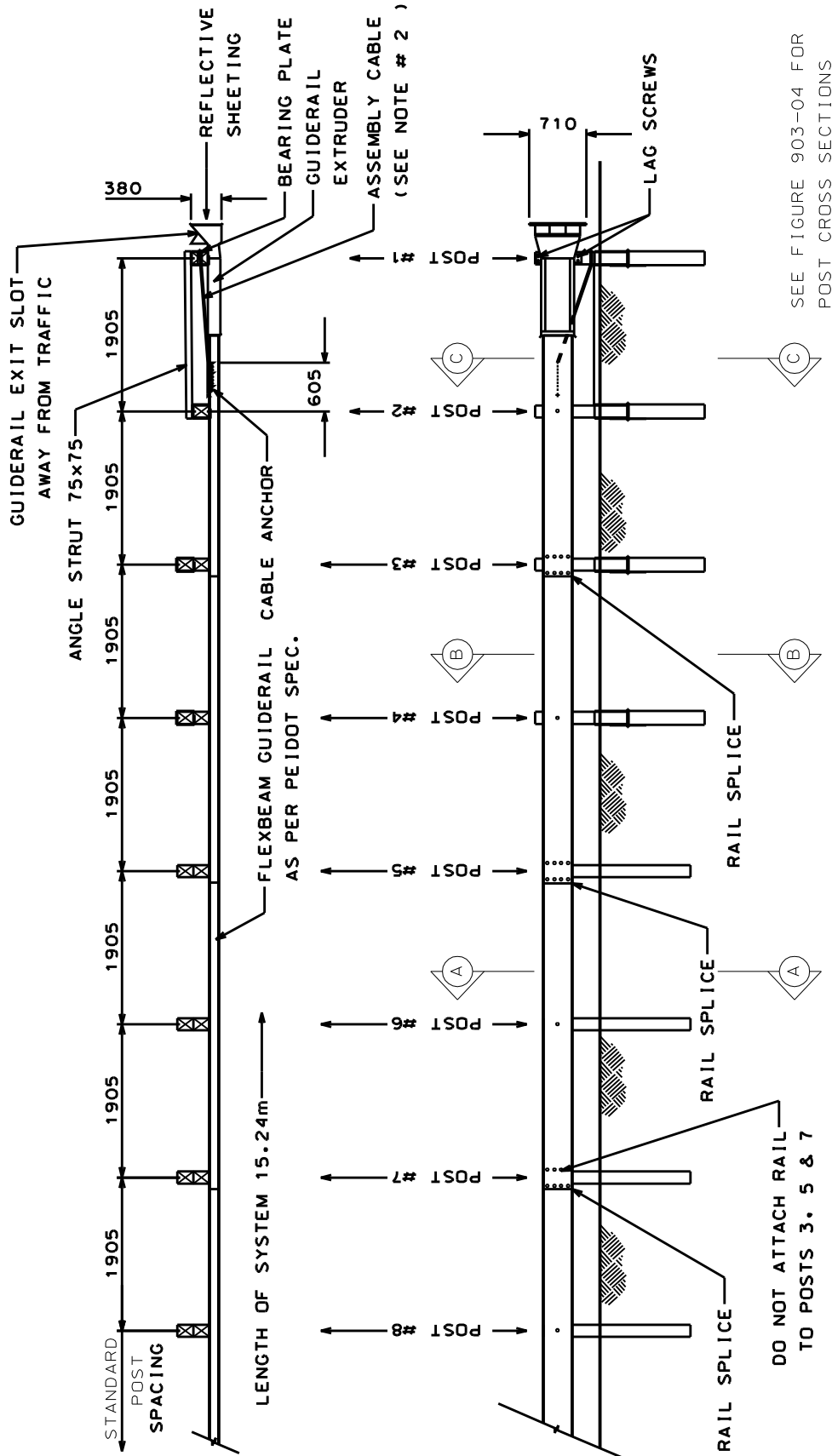

FIGURE 903-03 GUIDERAIL EXTRUDER ASSEMBLY PLAN & ELEVATION

2005

- NOTES:
1. INSTALL RAIL PARALLEL TO ROADWAY EDGE LINE WHEN TAPER IS REQUIRED BY DESIGN ENGINEER. A 50:1 TAPER OVER THE LENGTH OF THE SYSTEM IS ALLOWABLE
  2. AFTER FINAL ASSEMBLY RE-CHECK ASSEMBLY CABLE TO ENSURE IT IS TAUGHT AND HAS NOT RELAXED.
  3. DO NOT ATTACH GUIDERAIL TO POST #1.
  4. DO NOT ATTACH GUIDERAIL TO POST BLOCKS AT SPLICE LOCATIONS AT POSTS 3, 5 & 7.
  5. A FLAT WASHER IS USED UNDER THE NUT BEHIND THE POST ONLY. NO WASHER IS USED ON THE FRONT OF THE RAIL FOR THE LENGTH OF THE SYSTEM.
  6. PROVIDE REFLECTIVE SHEETING ON END OF GUIDERAIL EXTRUDER ASSEMBLY.

GENERAL PROVISIONS AND CONTRACT SPECIFICATIONS  
FOR HIGHWAY CONSTRUCTION  
DEPARTMENT OF TRANSPORTATION AND PUBLIC WORKS

ERECTION OF GUIDERAIL EXTRUDER SYSTEM

903

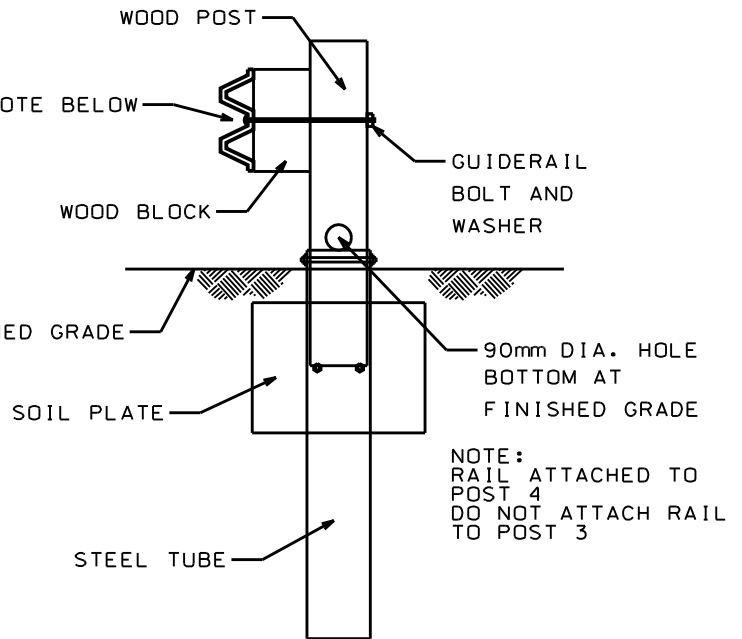
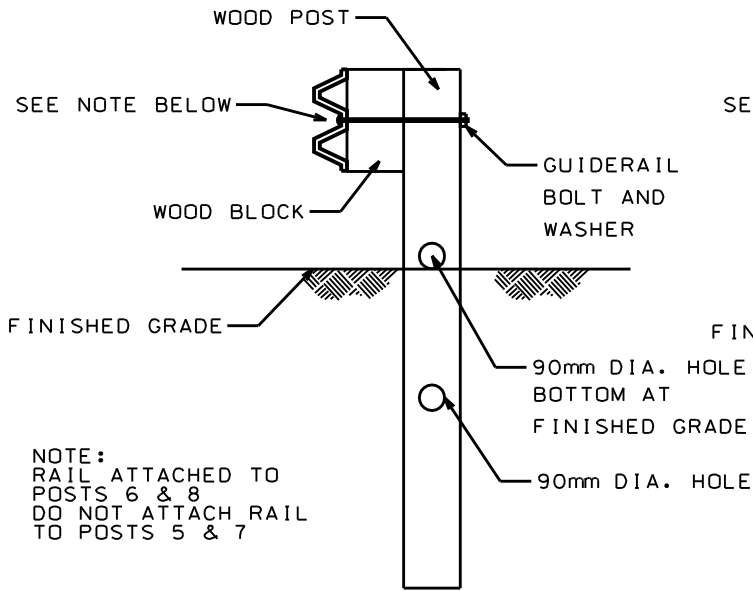

SECTION A-A POSTS 5, 6, 7 & 8

SECTION B-B POSTS 3 & 4

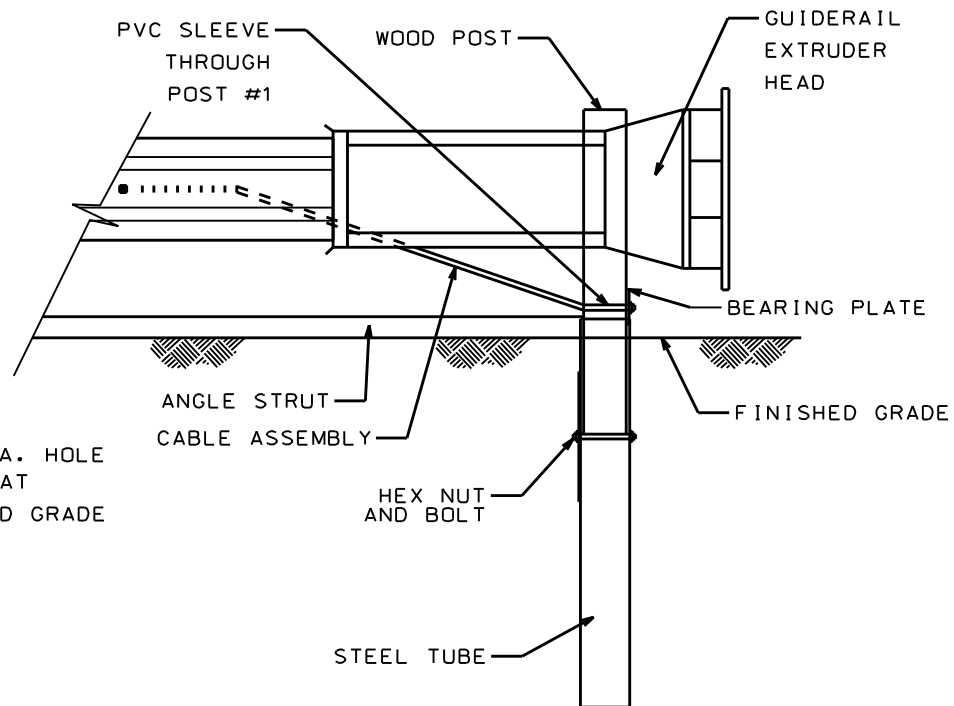
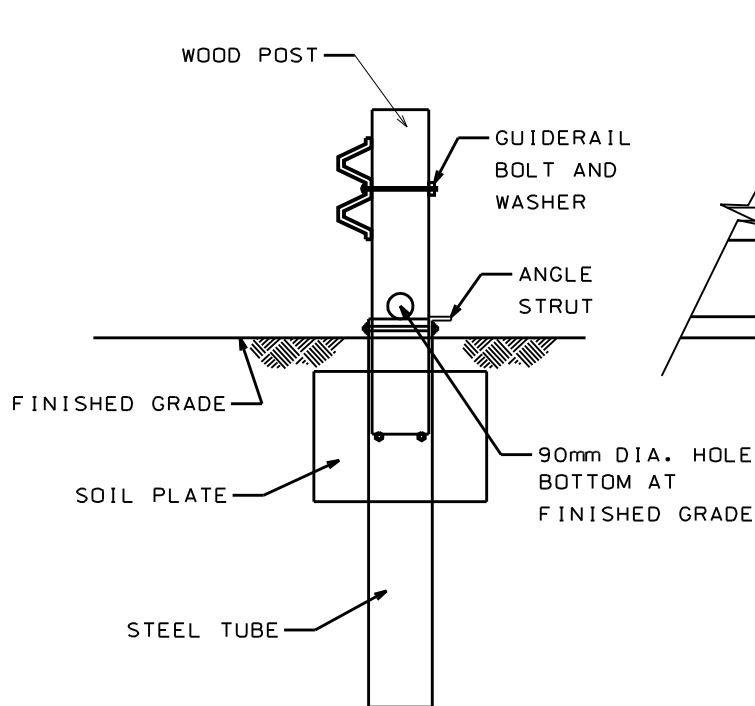

SECTION C-C POST 2

ELEVATION POST 1

FIGURE 903-04 GUIDERAIL EXTRUDER POST SECTIONS & ELEVATION

**GENERAL PROVISIONS AND CONTRACT SPECIFICATIONS  
FOR HIGHWAY CONSTRUCTION**

DEPARTMENT OF TRANSPORTATION AND PUBLIC WORKS

---

**CONSTRUCTION ZONE EDGE DELINEATION**

**904**

904.01 Description

The work under this Section consists of the supply, erection, maintenance and removal of delineators along the edge of the travelling surface within the construction zone.

904.02 Material

Construction zone edge delineation shall consist of signs having alternating black and high intensity reflective orange stripes of at least 120 mm in width. The minimum size of the delineator sign shall be 300 mm wide by 600 mm high. The delineator shall be in accordance with Figure 904-1.

904.03 Construction Method

Construction zone edge delineation shall be supplied, erected and maintained along all edges of the travelling surface within the construction zone. Delineators shall be placed as work progresses with no sections under construction left undelineated overnight. Delineators shall be maintained until immediately prior to placement of shoulder material when they shall be removed from the work site.

The delineators shall be erected 1 m towards the centreline from the outer edge of the shoulder at a spacing of 100 m on highway sections, or as specified by the Engineer. The delineator shall be erected so that the bottom of the delineator sign is between 800 mm and 1200 mm above the top of the travelling surface .

904.04 Maintenance

The delineators shall be maintained in proper position and must be clean and legible at all times. Maintenance shall include removal and reinstallation as required by the Engineer. Damaged or faded delineators shall be repaired or replaced as soon as possible.

904.05 Method of Measurement

Construction zone edge delineation shall be measured by the number of delineators erected and maintained. The number may be recorded at any time between the erection and removal of the delineators. Those delineators erected but not maintained will not be recorded.

904.06 Basis of Payment

Payment under this Section shall be at the unit bid price per Construction zone edge delineator.

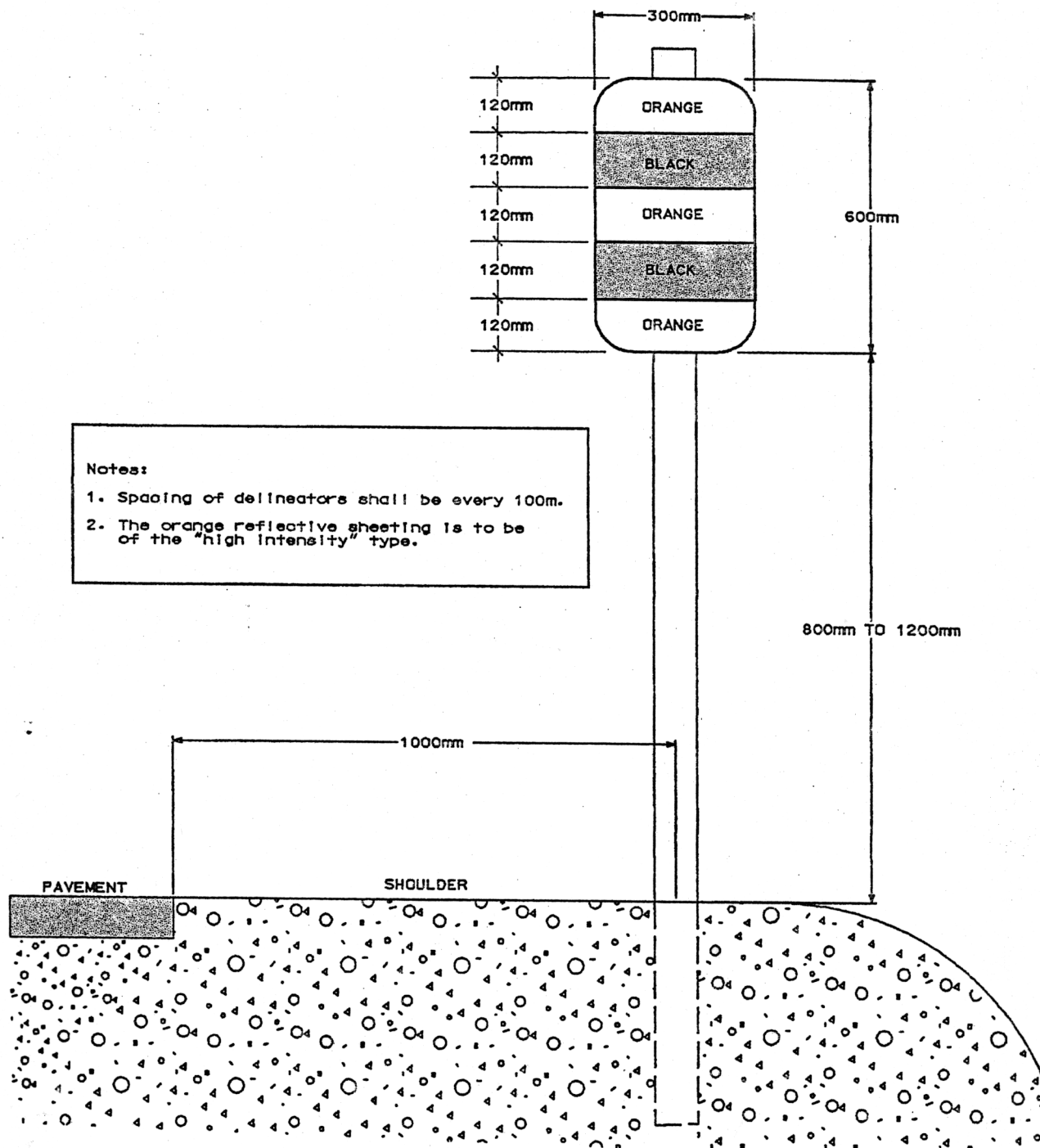

ELEVATION (N.T.S.)

FIGURE 904-01 PAVEMENT EDGE DELINEATOR  
REVISED 2001

**GENERAL PROVISIONS AND CONTRACT SPECIFICATIONS  
FOR HIGHWAY CONSTRUCTION**

DEPARTMENT OF TRANSPORTATION AND PUBLIC WORKS

---

**TEMPORARY MARKING**

**905**

905.01 Description

Temporary marking shall be placed on all new asphaltic concrete base and seal courses, all surface treatments including slurry seal and chip seal, all milled pavement surfaces and all tack coated asphaltic concrete base courses as work progresses with no new road surface left unmarked overnight.

905.02 Material

Temporary marking shall consist of reflective pavement marking tape with adhesive backing. The adhesive shall adhere the tape to the roadway surface so that the tape is not removed, displaced, rolled or torn by traffic. Temporary marking tape, 100 mm in width shall be supplied by the Contractor.

905.03 Construction Method

Yellow tape is to be used to separate lanes of traffic in opposing directions. White tape is to be used to separate lanes of traffic in the same direction.

The tape is to be placed in 500 mm lengths every 20 m or as specified by the Engineer.

905.04 Method of Measurement

Measurement for payment under this Section shall be the number of linear metres of tape applied.

905.05 Basis of Payment

Payment under this Section shall be at the unit bid price per linear metre and this price shall be full compensation for supply and application of temporary marking, tools, labour, equipment and incidentals necessary to carry out the work.

**GENERAL PROVISIONS AND CONTRACT SPECIFICATIONS  
FOR HIGHWAY CONSTRUCTION**

DEPARTMENT OF TRANSPORTATION AND PUBLIC WORKS

---

**TRAFFIC CONTROL DEVICES**

**906**

906.01 Scope

The requirement of this Section is that the Contractor have a supply of traffic control devices available on the work site before construction begins.

906.02 Material

The Contractors shall have the following traffic control devices on the work site before construction begins:

- 40 traffic cones
- 40 plastic traffic posts
- 2 construction zone signs
- 2 construction ahead signs
- 2 Work Zone signs

In addition to the listed traffic control devices the Contractor must have the following at all arterial highway work sites:

- 40 traffic barrels
- 40 plastic traffic posts

As work progresses the Contractor must supply and maintain any additional traffic control devices as required by the Engineer.

Traffic barrels must be constructed of impact resistant, flexible low density polyethylene. Minimum wall thickness shall be 2.4 mm. The traffic barrel shall be 2 piece construction with a breakaway base that locks in place after ballast is placed in the barrel.

The height of the traffic barrel shall be not more than 1 m and not less than 910 mm. The outside diameter of the barrel shall be 585 mm and the barrel shall be tapered to an outside top diameter of 455 mm.

The colour of the traffic barrel shall be "safety orange" and shall have 5 reflective alternating bands of orange and white high intensity sheeting. The minimum width of each band of sheeting shall be 100 mm and shall be the same circumference of the traffic barrel.

906.03 Construction Method

The traffic control devices are to be placed on the work site as required in accordance with the Traffic Control Procedures for Road Work of Appendix 3 to indicate a safe roadway for traffic.

The above requirements do not alleviate the Contractor's responsibility of accommodating traffic in accordance with Provision 105.07.

906.04 Method of Measurement

There shall be no measurement for payment under this Section.

906.05 Basis of Payment

The provision of all signs, traffic cones and barrels are incidental to the work.

**GENERAL PROVISIONS AND CONTRACT SPECIFICATIONS  
FOR HIGHWAY CONSTRUCTION**

DEPARTMENT OF TRANSPORTATION AND PUBLIC WORKS

---

**VEHICLE CONFIGURATIONS AND RESTRICTIONS**

**907**

907.01 Scope

This Section specifies the vehicle configuration which may be used to haul various materials to the work site and the type of traffic control that must be in place for each highway project depending on traffic control (i.e. approved detours) and traffic volumes (i.e. Summer Average Daily Traffic - SADT).

907.02 Vehicle Configurations on all Highway Projects

Truck: Single unit vehicle with end dump, 2 or 3 axles, no trailers.

Truck with Pup Trailer (TPT): Truck with 2 or 3 axle trailer connected to the truck by a drawbar.

Tractor Semi-Trailer (TST): 2 or 3 axle tractor with 2 or 3 axle end-dump semi-trailer connected through a 5th wheel and kingpin.

Tractor Belly Dump (TBD): 2 or 3 axle tractor with 2 or 3 axle belly dump semi-trailer connected through a 5th wheel and kingpin.

Train: 2 or 3 axle tractor with more than 1 trailer or semi-trailer.

Tractor with Flow -Boy Trailer (TFB): 2 or 3 axle tractor with 2 or 3 axle semi-trailer connected through a 5th wheel and a kingpin and the semitrailer is equipped with a conveyor in the floor to unload to the rear of the trailer.

907.03 Vehicle Restrictions on Highway Projects with an Approved Detour

907.03.01 Materials Haul Restrictions

1. Only trucks and tractors with flow-boy trailers will be permitted to haul asphaltic concrete and RAP.
2. Only trucks, trucks with pup trailers, and tractors with flow-boy trailers will be permitted to haul shoulder material.
3. Unless restricted in other sections of this policy, trucks, trucks with pup trailers, tractor semi-trailers, tractor belly dumps and tractors with flow-boy trailers will be permitted to haul bulk materials on the work site.
4. Trains will not be permitted to haul any materials.

907.03.02 Traffic Restrictions

1. All vehicles may haul in any order.

907.03.03 Safety Requirements

1. Tractor semi-trailers will not be permitted to dump on roads where the super-elevation or cross-slope is greater than 3%.
2. Tractor semi-trailers will not be permitted to move ahead or in reverse with the dump body raised.

**GENERAL PROVISIONS AND CONTRACT SPECIFICATIONS  
FOR HIGHWAY CONSTRUCTION**

DEPARTMENT OF TRANSPORTATION AND PUBLIC WORKS

---

**VEHICLE CONFIGURATIONS AND RESTRICTIONS**

**907**

907.03.04     Contractor Requirements

1.     The Contractor must provide sufficient equipment for spreading the material after dumping.
2.     The Contractor must prepare a levelled area where tractor semi-trailers are permitted to dump.

907.04 Vehicle Restrictions on Highway Projects with SADT < 1000

907.04.01     Material Haul Restrictions

1.     Only trucks and tractors with flow-boy trailers will be permitted to haul asphaltic concrete and RAP.
2.     Only trucks, trucks with pup trailers, and tractors with flow-boy trailers will be permitted to haul shoulder material.
3.     Unless restricted in other sections of this policy, trucks, trucks with pup trailers, tractor semi-trailers, tractor belly dumps and tractors with flow-boy trailers will be permitted to haul bulk materials on the work site.
4.     Trains will not be permitted to haul any materials.

907.04.02     Traffic Restrictions

1.     All vehicles may haul in any order.
2.     On gravel and sandstone hauls, all vehicles must turn in a designated turning area if one is provided by the Contractor.

907.04.03     Safety Requirements

1.     Any designated turning area must have safe stopping sight distance at the entrance and exit.
2.     Tractor semi-trailers will not be permitted to dump on roads where the super-elevation or cross-slope is greater than 3%.
3.     Tractor semi-trailers will not be permitted to move ahead or in reverse with the dump body raised.
4.     Traffic must be stopped from the time the tractor semi-trailer starts to raise the dump body until the empty dump body has been lowered to the level of the top of the tractor cab.
5.     Signallers must control all areas where any vehicle is in the dumping queue. This requirement includes entering, waiting, dumping and leaving the queue.
6.     No loaded vehicles will be permitted to turn on the travelled portion of the highway.
7.     The dumping sequence for trucks must comply with the 3 stages of Figure 907-01 when the paving operation is proceeding toward the asphalt plant.
8.     The dumping sequence for tractor semi-trailers must comply with the 4 stages of Figure 907-02.

907.04.04     Contractor Requirements

1.     The Contractor must provide sufficient equipment for spreading the material after dumping.
2.     The Contractor must prepare a level plane where tractor semi-trailers are permitted to dump.



**GENERAL PROVISIONS AND CONTRACT SPECIFICATIONS  
FOR HIGHWAY CONSTRUCTION**

DEPARTMENT OF TRANSPORTATION AND PUBLIC WORKS

---

**VEHICLE CONFIGURATIONS AND RESTRICTIONS**

**907**

3. The Contractor must provide 2 additional signallers, 1 located at each end of the tractor semi-trailer, at sites where tractor semi-trailers are permitted.

907.05 Vehicle Restrictions on Highway Projects with SADT >1000 but <4000

907.05.01 Material Haul Restrictions

1. Only trucks and tractors with flow-boy trailers will be permitted to haul asphaltic concrete and RAP.
2. Only trucks, trucks with pup trailers, and tractors with flow-boy trailers will be permitted to haul shoulder material.
3. Unless restricted in other sections of this policy, trucks, trucks with pup trailers, tractor semi-trailers, tractor belly dumps and tractors with flow-boy trailers will be permitted to haul bulk materials on the work site.
4. Trains will not be permitted to haul any materials.

907.05.02 Traffic Restrictions

1. On gravel and sandstone hauls, all vehicles must turn in a designated turning area if one is provided by the Contractor.
2. Tractor semi-trailers may only haul on the ratio of 1 tractor semi-trailer to 3 other haul vehicles.

907.05.03 Safety Requirements

1. Any designated turning area must have safe stopping sight distance at the entrance and exit.
2. Tractor semi-trailers will not be permitted to dump on roads where the super-elevation or cross-slope is greater than 3%.
3. Tractor semi-trailers will not be permitted to move ahead or in reverse with the dump body raised.
4. Traffic must be stopped from the time the tractor semi-trailer starts to raise the dump body until the empty dump body has been lowered to the level of the top of the tractor cab.
5. Signallers must control all areas where any vehicle is in the dumping queue. This requirement includes entering, waiting, dumping and leaving the queue.
6. No loaded vehicles will be permitted to turn on the travelled portion of the highway.
7. The dumping sequence for trucks must comply with the 3 stages of Figure 907-01 when the paving operation is proceeding toward the asphalt plant.
8. The dumping sequence for tractor semi-trailers must comply with the 4 stages of Figure 907-02.

907.05.04 Contractor Requirements

1. The Contractor must provide sufficient equipment for spreading the material after dumping.
2. The Contractor must prepare a levelled area where tractor semi-trailers are permitted to dump.
3. The Contractor must provide 2 additional signallers, 1 located at each end of the tractor semi-trailer, at sites where tractor semi-trailers are permitted.

**GENERAL PROVISIONS AND CONTRACT SPECIFICATIONS  
FOR HIGHWAY CONSTRUCTION**

DEPARTMENT OF TRANSPORTATION AND PUBLIC WORKS

---

**VEHICLE CONFIGURATIONS AND RESTRICTIONS**

**907**

907.05.05     Truckers Association Requirements

The Prince Edward Island Truckers Association is responsible for enforcing the ratio of 1 tractor semi-trailers to 3 other haul vehicles prior to loading and weighing. This ratio is to be enforced prior to leaving the loading area.

907.06 Vehicle Restrictions on Highway Projects with SADT > 4000

907.06.01     Material Haul Restrictions

1.     Only trucks and tractors with flow-boy trailers will be permitted to haul asphaltic concrete and RAP.
2.     Only trucks, trucks with pup trailers, and tractors with flow-boy trailers will be permitted to haul shoulder material.
3.     Unless restricted in other sections of this policy, trucks, trucks with pup trailers, tractor belly dumps and tractors with flow-boy trailers will be permitted to haul bulk materials on the work site.
4.     Tractor semi-trailers and trains will not be permitted to haul any materials.

907.06.02     Traffic Restrictions

1.     On gravel and sandstone hauls, all vehicles must turn in a designated turning area if one is provided by the Contractor.

907.06.03     Safety Requirements

1.     Any designated turning area must have safe stopping sight distance at the entrance and exit.
2.     Signallers must control all areas where any vehicle is in the dumping queue. This requirement includes entering, waiting, dumping, and leaving the dumping queue.
3.     No loaded vehicles will be permitted to turn on the travelled portion of the highway.
4.     The dumping sequence for trucks must comply with the 3 stages of Figure 907-01 when the paving operation is proceeding toward the asphalt plant.

907.07 Method of Measurement

There shall be no measurement for payment under this Section.

907.08 Basis of Payment

Compliance with this Section shall be incidental to the work.

GENERAL PROVISIONS AND CONTRACT SPECIFICATIONS  
FOR HIGHWAY CONSTRUCTION  
DEPARTMENT OF TRANSPORTATION AND PUBLIC WORKS

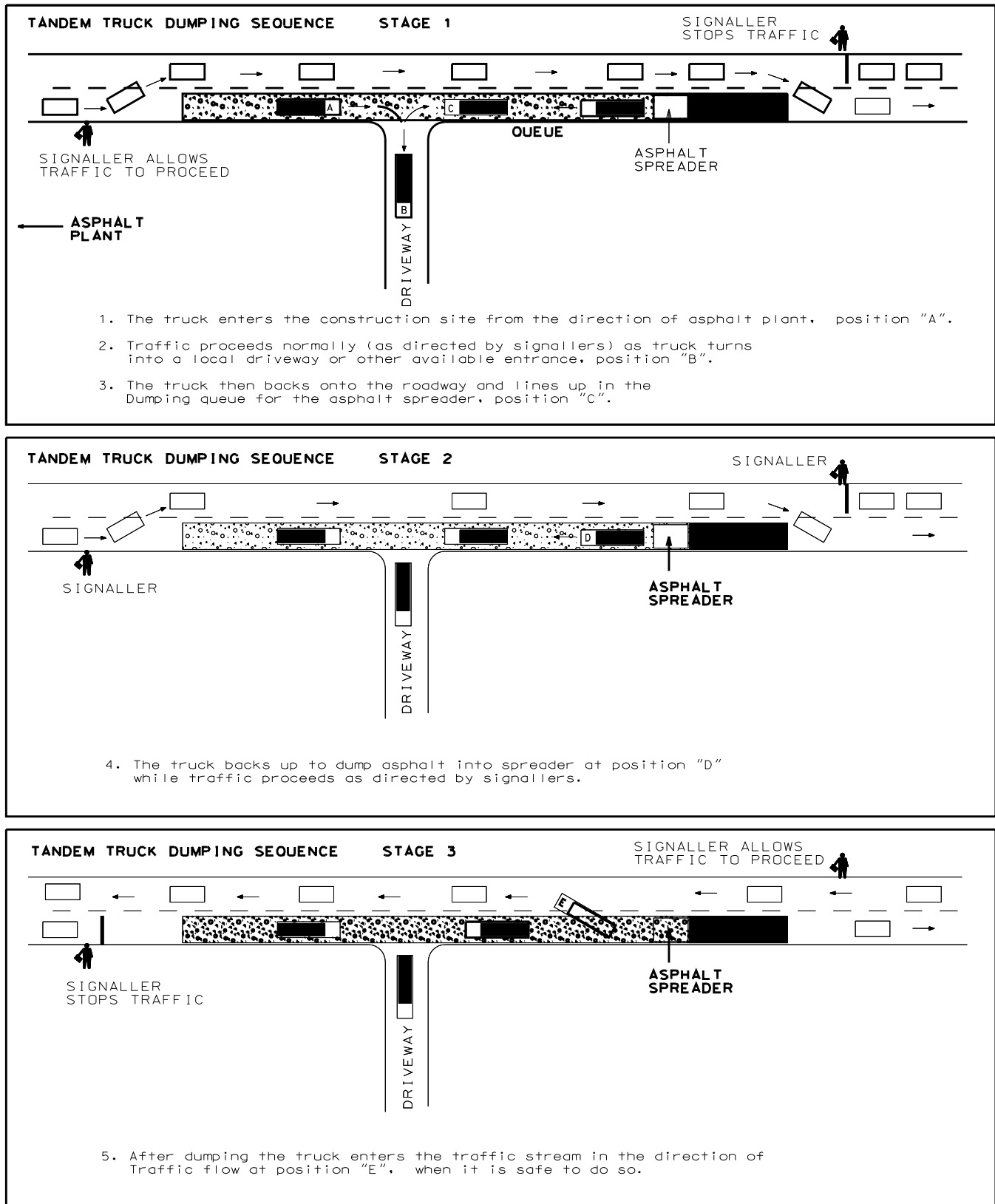

**FIGURE 907-01 TANDEM TRUCK DUMPING SEQUENCE**  
**REVISED 2001**

GENERAL PROVISIONS AND CONTRACT SPECIFICATIONS  
FOR HIGHWAY CONSTRUCTION  
DEPARTMENT OF TRANSPORTATION AND PUBLIC WORKS

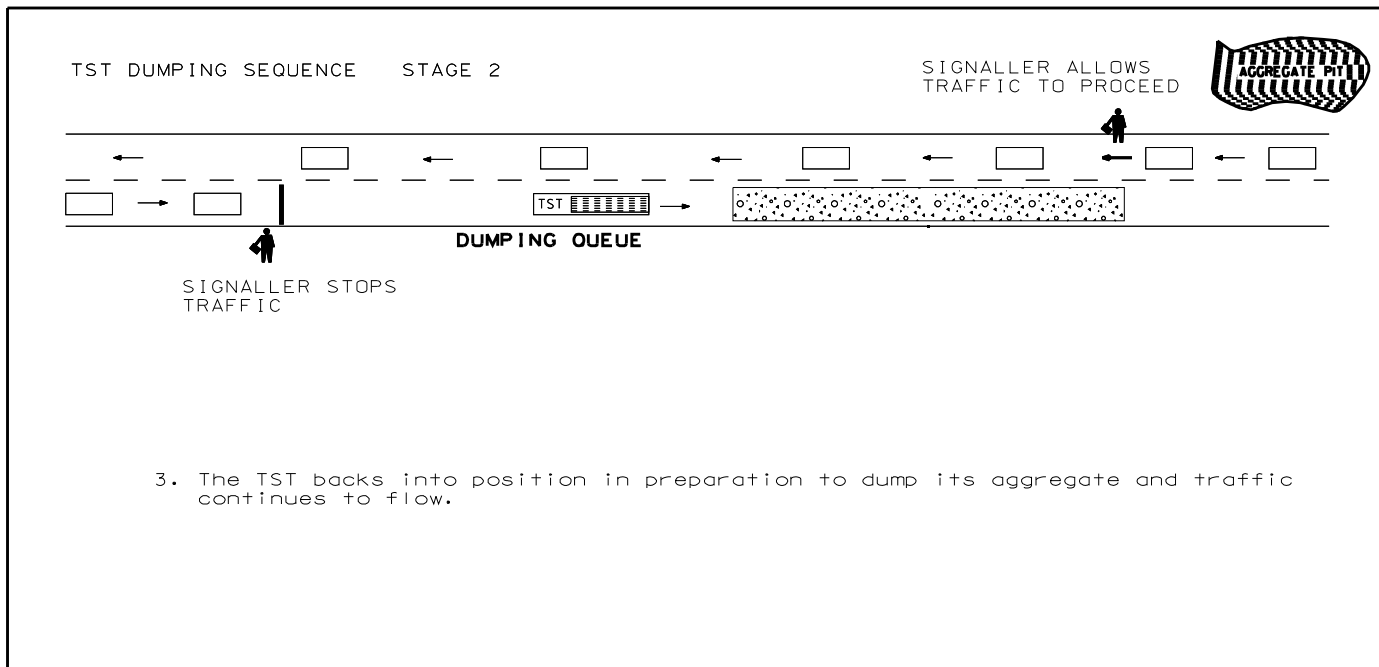
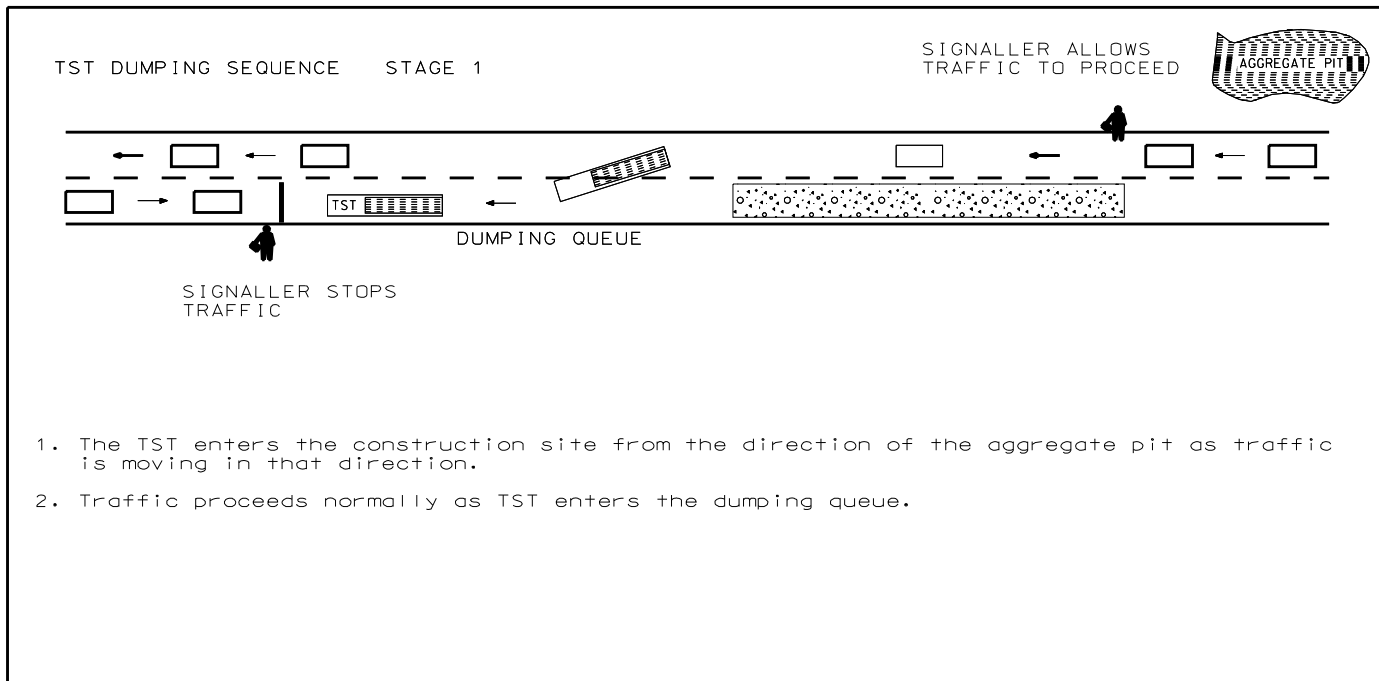

**FIGURE 907-02 TRACTOR SEMI-TRAILER DUMPING SEQUENCE (1 OF 2)**

REVISED 2001

GENERAL PROVISIONS AND CONTRACT SPECIFICATIONS  
FOR HIGHWAY CONSTRUCTION  
DEPARTMENT OF TRANSPORTATION AND PUBLIC WORKS

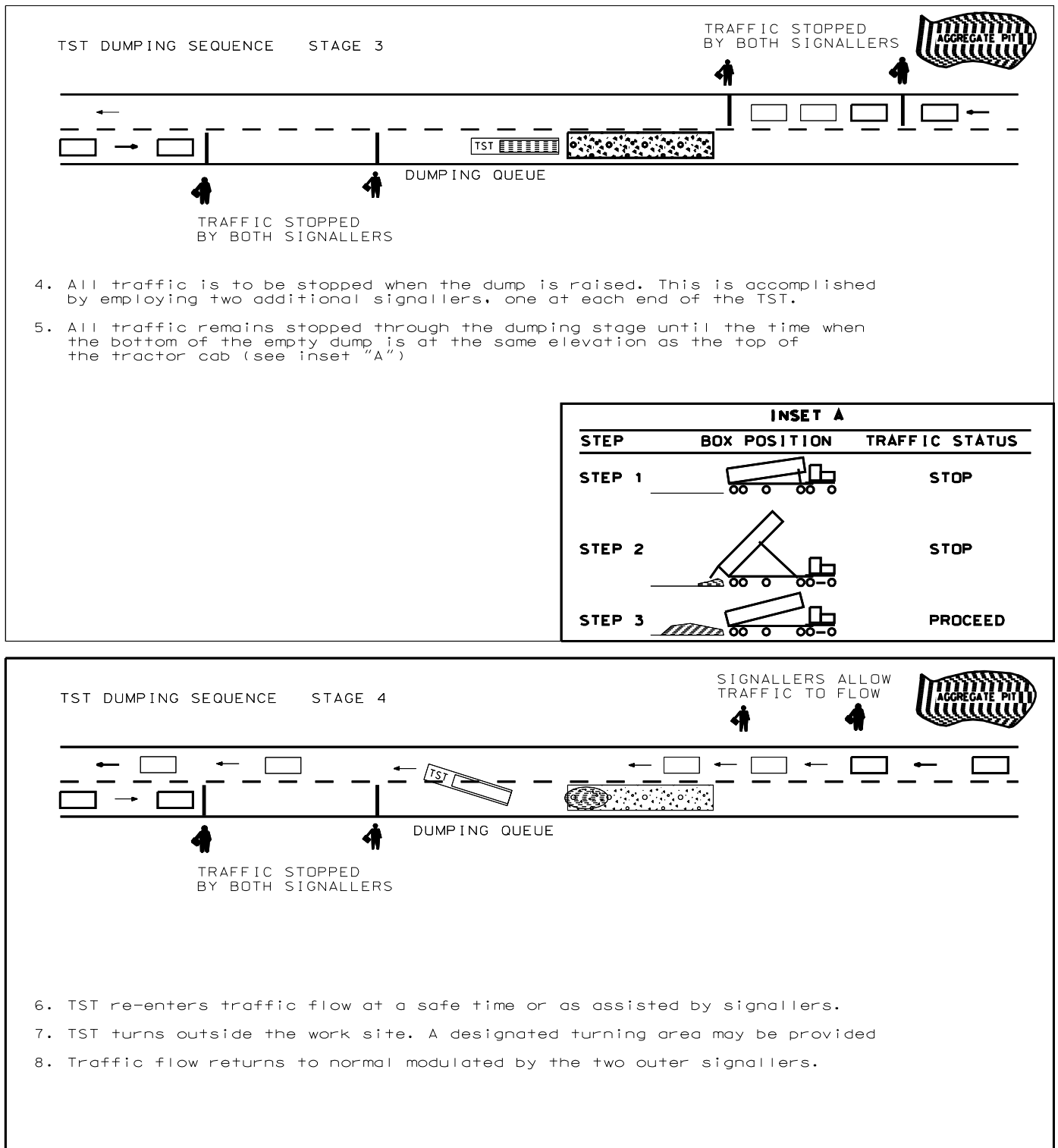

**FIGURE 907-02 TRACTOR SEMI-TRAILER DUMPING SEQUENCE (2 OF 2)**

REVISED 2001

**GENERAL PROVISIONS AND CONTRACT SPECIFICATIONS  
FOR HIGHWAY CONSTRUCTION**

DEPARTMENT OF TRANSPORTATION AND PUBLIC WORKS

---

**TRAFFIC CONTROL PLAN**

**908**

908.01 Description

This work shall consist of the preparation, implementation, maintenance and supervision associated with a Traffic Control Plan.

908.02 Preparation

On contracts where requested in the Tender, the Contractor shall provide the Engineer with a Traffic Control Plan (TCP) at least five working days prior to the commencement of construction. The TCP will describe the temporary traffic controls to be used on the site at all times during the various phases of construction. The TCP will pay special attention to areas with more than 2 lanes, intersections, detours, accommodating pedestrians in urban areas, and any other areas requested by the Engineer.

908.03 Traffic Control Manager

On all contracts where a TCP is required, the Contractor shall have a Traffic Control Manager whose sole responsibility is to control traffic on the site at all times when work is underway. The Contractor will designate the Traffic Control Manager to the Engineer at least five working days prior to commencement of the work. The Traffic Control Manager shall be trained in Work Zone Traffic Control, and shall be responsible for the supervision of all signallers, compliance with the TCP, and the condition, placement, relocation, and removal of all traffic control devices. The Traffic Control Manager shall maintain daily records of the number, location and condition of all traffic control devices on the site.

908.04 Revisions

\_\_\_\_\_ Revisions to the TCP may be made with the Engineers approval. Revisions must be requested at least 2 working days prior to implementation.

908.05 Equipment

\_\_\_\_\_ Traffic Control Devices used in the TCP must comply with those in Appendix 3 or receive approval from the Engineer at least 2 working days prior to implementation.

908.06 Method of Measurement

\_\_\_\_\_ Measurement for this section will be based on the provision of a Traffic Control Plan and a Traffic Control Manager providing active traffic control on the site.

**GENERAL PROVISIONS AND CONTRACT SPECIFICATIONS  
FOR HIGHWAY CONSTRUCTION**

DEPARTMENT OF TRANSPORTATION AND PUBLIC WORKS

---

**TRAFFIC CONTROL PLAN**

**908**

---

908.07 Basis of Payment

\_\_\_\_\_ Payment under this section shall be at the unit price per hour set by the Department and this price shall be full compensation for the following:

- providing a written Traffic Control Plan with drawings covering the placement of signs, signallers, detours and all other traffic control devices associated with the work site;
- providing any revisions to the Traffic Control Plan and drawings;
- providing a Traffic Control Manager whose sole responsibility is to control traffic on the site at all times when work is underway, who supervises the signallers; installs, maintains and removes all traffic control devices and maintains daily records of the traffic control devices and signallers on the site.

**GENERAL PROVISIONS AND CONTRACT SPECIFICATIONS  
FOR HIGHWAY CONSTRUCTION  
DEPARTMENT OF TRANSPORTATION AND PUBLIC WORKS**

---

**INSTALLATION OF GUIDERAIL END TREATMENT**

**909**

909.01 Description

This work shall consist of the installation of guiderail end treatment at the end of a section of installed guiderail.

909.02 Material

Unless otherwise specified, all materials to be used in the installation of guiderail end treatment shall be provided by the Department in accordance with Section 104.13.

909.03 Construction Method

The contractor shall install the guiderail end treatment at the locations indicated by the Engineer.

The guiderail end treatment shall be installed according to the manufacturers instructions as provided in the Special Provisions.

909.04 Method of Measurement

The quantity to be measured under this section shall be the number of guiderail end treatments installed.

909.05 Basis of Payment

Payment under this Section shall be at the unit bid price for guiderail end treatment installation and this price shall be full compensation for the installation of guiderail end treatment, tools, labour, equipment, and incidentals necessary to complete the work.



**GENERAL PROVISIONS AND CONTRACT SPECIFICATIONS  
FOR HIGHWAY CONSTRUCTION**

DEPARTMENT OF TRANSPORTATION AND PUBLIC WORKS

---

**ELECTRICAL**

**1000**

- 1001 Electrical General Provisions
- 1002 Telephone Ductbank
- 1003 Basic Materials
- 1004 Traffic Signals

**GENERAL PROVISIONS AND CONTRACT SPECIFICATIONS  
FOR HIGHWAY CONSTRUCTION**

DEPARTMENT OF TRANSPORTATION AND PUBLIC WORKS

---

**ELECTRICAL GENERAL PROVISIONS**

**1001**

1001.01     Scope

This Section details the requirements for traffic signal systems and ductwork as shown on the Drawings or as specified.

1001.02     Codes and Standards

Installation must be in accordance with CSA 22.1 except where otherwise specified.

Must comply with the CSA Electrical Bulletins in force at time of Tender submission; while not identified and specified by number in this Division, the Bulletins are to be considered as part of the related CSA Part II standard.

Abbreviations for electrical terms: to CSA Z85.

1001.03     Permits and Fees

Submit to the Electrical Inspection Division of the Department of Labour the necessary number of drawings and specifications for examination and approval prior to commencement of work.

Must pay associated fees.

Engineer will provide Drawings at no cost.

1001.04     Care, Operation and Start-Up

Instruct operating personnel in the operation, care and maintenance of equipment.

Arrange and pay for the services of the manufacturer's factory service engineer to supervise start-up of the installation and to check, adjust, balance and calibrate the components.

Provide services for such period and for as many visits as necessary to put equipment in operation and to ensure that operating personnel are conversant with all aspects of the equipment's care and operation.

1001.05     Voltage Ratings

Operating voltages: to CSA C235.

Motors, electric heating, control and distribution devices and equipment to operate satisfactorily at 60 Hz within normal operating limits established by CSA C235 Equipment to operate in extreme operating conditions as established in above standard without damage.

1001.06     Inspection

Furnish a Certificate of Acceptance from the Chief Electrical Inspector of the Province of Prince Edward Island.

**GENERAL PROVISIONS AND CONTRACT SPECIFICATIONS  
FOR HIGHWAY CONSTRUCTION**

DEPARTMENT OF TRANSPORTATION AND PUBLIC WORKS

---

**ELECTRICAL GENERAL PROVISIONS**

**1001**

1001.07     Materials and Equipment

Equipment and material to be CSA certified and manufactured to standard quoted.

1001.08     Finishes

Shop finish metal enclosure surfaces by removing rust and scale, cleaning, applying rust resistant primer inside and outside and by applying a minimum of 2 coats of finish enamel.

Clean and touch up surfaces of shop-painted equipment scratched or marred during shipment or installation, to match original paint.

Clean, prime and paint exposed hangers, racks and fastenings to prevent rusting.

1001.09     Wiring Identification

Identify wiring, with permanent identifying numbers, on both ends of phase conductors of feeders and branch circuit wiring.

Maintain phase sequence and colour coding throughout.

Colour code wiring to CSA C22.1.

Ensure that colour coded wires in traffic control cable are matched throughout the system.

Provide colour coding of the traffic signal wiring system as indicated on the Contract Drawings.

1001.10     Wiring Terminations

Lugs, terminals and screws used for termination of wiring must be suitable for either copper or aluminum conductors.

1001.11     Manufacturer's and CSA Labels

Manufacturer's nameplates and CSA labels are to be visible and legible after equipment is installed.

1001.12     Warning Signs

Provide warning signs, as specified or to meet requirements of the Chief Electrical Inspector of the Province of Prince Edward Island.

Use decal signs that are a minimum of (20 x 300 mm) in size.

1001.13     Protection

Protect exposed live equipment during construction for personnel safety.

Shield and mark all live parts, (i.e. "LIVE 120 VOLTS"), with appropriate voltage.

**GENERAL PROVISIONS AND CONTRACT SPECIFICATIONS  
FOR HIGHWAY CONSTRUCTION**

DEPARTMENT OF TRANSPORTATION AND PUBLIC WORKS

---

**ELECTRICAL GENERAL PROVISIONS**

**1001**

1001.14      Conduit and Cable Installation

Install conduit and sleeves prior to the pouring of concrete.

Install cables, conduits and fittings, that are to be embedded or plastered over, neatly and close to the structure so that furring is minimized.

1001.15      Tests

Conduct and pay for all tests for control, signal and traffic systems installed under this Contract.

Carry out tests in the presence of the Engineer.

Provide instruments, meters, equipment and personnel required to conduct tests during and at conclusion of project.

Submit test results.

Furnish manufacturer's certificate or letter confirming that entire installation as it pertains to each system has been installed to manufacturer's instructions.

1001.16      Insulation Resistance Testing

Megger circuits, feeders and equipment up to 350 V with a 500 V instrument.

Check resistance to ground before energizing.

1001.17      Coordination of Protective Devices

Ensure that circuit protective devices such as over current trips, relays and fuses, are installed to values and settings as specified.

1001.18      Cleaning

Do cleaning in accordance with Provision 103.04.

**GENERAL PROVISIONS AND CONTRACT SPECIFICATIONS  
FOR HIGHWAY CONSTRUCTION**

DEPARTMENT OF TRANSPORTATION AND PUBLIC WORKS

---

**TELEPHONE DUCTBANK**

**1002**

1002.01

Description

Work in this Section includes supply and installation of the concrete encased telephone ductbank as indicated on the Drawings and as specified.

1002.02

Material

PVC duct type EBII.

Marker tape: yellow plastic that is suitable for direct burial.

Pulling rope: 6 mm diameter nylon in each duct.

Concrete to be in accordance with Section 1101.

1002.03

Construction Method

Install underground ductbanks as indicated.

Install ducts founded on undisturbed soil or on well compacted bedding material in accordance with Section 220.

Make transpositions, offsets and changes in direction using 5<sup>0</sup> bend sections.

Install marker tape and backfill with materials indicated on the Drawings.

The Contractor must prove that all ducts are clear of obstructions before the Engineer will accept the work. This will be accomplished by blowing a flight through each duct and pulling an approved plug or mandrel through each duct or by a similar approved process. Each duct will be strung using nylon pulling ropes.

Ducts are to be supported at 1.5 m intervals using interlocking type spacers with vertical and horizontal interlocks. Base and intermediate spacers are to be used and assembled according to manufacturer's instructions.

Ducts are to be joined using solvent weld couplings or suitable waterproof couplings. Ensure these junctions are smooth and free of any sharp protrusions which could damage cables being pulled into the ducts.

Stagger coupling of conduits to bell ends both vertically and horizontally a minimum of 150 mm.

1002.04

Inspection

Do not backfill until the Engineer has inspected the work.

**GENERAL PROVISIONS AND CONTRACT SPECIFICATIONS  
FOR HIGHWAY CONSTRUCTION**

DEPARTMENT OF TRANSPORTATION AND PUBLIC WORKS

---

**TELEPHONE DUCTBANK**

**1002**

1002.05      Method of Measurement

The quantity to be measured under this Section shall be the number of linear metres of ductbank measured horizontally along the centreline for each type of ductbank constructed terminating at the vertical faces of the structures.

1002.06      Basis of Payment

Payment under this Section shall be at the unit bid price per linear metre and this price shall be full compensation for constructing ductbanks, trench excavation and backfilling, disposal of surplus materials, supply and placement of ducts, spacers, jointing, concrete, formwork, bedding, marker tape and incidentals necessary to complete the work and testing.

**GENERAL PROVISIONS AND CONTRACT SPECIFICATIONS  
FOR HIGHWAY CONSTRUCTION**

DEPARTMENT OF TRANSPORTATION AND PUBLIC WORKS

---

**BASIC MATERIALS**

**1003**

1003.01

Scope

This Section details basic materials. It should be noted that Drawings do not show all conduit and cable locations; those shown are in schematic form only.

1003.02

Material

Copper conductors: to CSA C22.2 No. 38-M.

Moulded case circuit breakers: to CSA C22.2 No. 5-M.

Grounding equipment: to CSA C22.2 No. 41-M.

1003.03

Conductors

Copper conductors for power supply and beacon light wiring: size as indicated with 600 V or 1000 V insulation of chemically cross-linked thermosetting polyethylene material rated RW90.

Traffic control cables: 7 conductor, 14 AWG, soft drawn, 7 strand copper with PVC insulation (type TW minus 40<sup>0</sup> C) rated 600 V, type IMSA 19/1 or equal.

Detector lead-in cable: 2 conductor, twisted and shielded, size 14-2, PVC jacketed, Belden #8720 - 600 V or approved equal.

Detector loops: IMSA 51/5 cable within a PVC Jacket installed as detailed on the Drawings.

1003.04

Connectors

Pressure type wire connectors: with current carrying parts of copper alloy sized to fit copper conductors as required.

Bushing stud connectors: to EEMAC 1Y-2 to consist of:

- Connector body and stud clamp for stranded copper conductors.
- Stud clamp bolts.
- Sized for conductors as indicated.

1003.05

Conduits

Rigid PVC conduit: to CSA C22.2 No. 211.2, size as indicated on the Drawings.

1003.06

Conduit Fastenings

One hole malleable iron straps to secure surface conduits 50 mm and smaller. Two hole steel straps for conduits larger than 50 mm.

1003.07

Conduit Fittings

Fittings manufactured for use with conduit specified.

Factory "ells" where 90<sup>0</sup> bends are required for 25 mm and larger conduits.

**GENERAL PROVISIONS AND CONTRACT SPECIFICATIONS  
FOR HIGHWAY CONSTRUCTION**

DEPARTMENT OF TRANSPORTATION AND PUBLIC WORKS

---

**BASIC MATERIALS**

**1003**

- 1003.08      Expansion Fittings for Rigid Conduit  
Watertight expansion fittings suitable for linear expansion and 20 mm deflection in all directions. Locate expansion fittings where indicated on the Drawings.
- 1003.09      Fittings - General  
Bushing and connectors with nylon insulated throats.  
Knock-out fillers to prevent entry of foreign materials.  
Conduit outlet bodies for conduit up to 32 mm and pull boxes for larger conduits.
- 1003.10      Service Fittings  
Service entrance fitting made of 2 piece PVC, size as indicated on drawings.
- 1003.11      Grounding Equipment  
Provide insulated ground conductor complete with connectors as indicated between ground lugs of controller equipment and ground rods, as indicated. Protect conductor with conduit as indicated.
- 1003.12      Traffic Loop Sealants  
Medium hard asphaltic base compound that requires heating for installation. Acceptable manufacturer: GTE Sylvania Canada Limited - Novoid C or approved equivalent.
- 1003.13      Disconnect Switch and Meter Base  
Provide a 2 pole 60 A disconnect switch in EEMAC 4X stainless steel enclosure. Provide 40 A fuses of type recommended by controller manufacturer.  
Provide utility meter base as required by Maritime Electric.
- 1003.14      Method of Construction
- 1003.14.01    Installation of Cables and Cable Supports  
Do not use wire lashing or perforated straps to support or secure raceways or cables.  
Do not use supports or equipment installed for other trades for conduit or cable support except with permission of the other trade and the approval of the Engineer.  
Install fastenings and supports as required for each type of equipment, cables and conduits and in accordance with manufacturer's installation recommendations.  
Conductors are shown on Drawings or in cable tables in approximate locations. Confirm locations of cable runs with Engineer before installation.



**GENERAL PROVISIONS AND CONTRACT SPECIFICATIONS  
FOR HIGHWAY CONSTRUCTION**

DEPARTMENT OF TRANSPORTATION AND PUBLIC WORKS

---

**BASIC MATERIALS**

**1003**

1003.14.02     Installation of Wire and Cable Connectors

Remove insulation carefully from ends of conductors and:

- Install mechanical pressure type connectors and tighten screws with appropriate tool recommended by manufacturer. Installation shall meet secureness tests in accordance with CSA C22.2 No. 65-M.
- Install crimp type connectors to manufacturer's recommendations.

1003.14.03     Installation of Conduit

Install conduits to cause minimum interference in spaces through which they pass.

Replace conduit if kinked or flattened more than 1/10th of its original diameter.

Install nylon fish cord in empty conduits.

Where conduits become blocked, remove and replace blocked section.

Dry conduits out before installing wire.

1003.14.04     Surface Conduits

Run parallel or perpendicular to structure lines.

1003.14.05     Conduit Poured in Concrete

Encase conduits completely in concrete as detailed on the Drawings.

1003.14.06     Installation of Ground

Install complete permanent, continuous, system in conduit to equipment and provide electrodes, conductors, connectors, accessories, as indicated on the drawings, to conform to requirements of the Engineer and the local authority having jurisdiction over installation.

Install connectors to manufacturer's instructions.

Protect exposed grounding conductors from mechanical injury.

Make buried connections, electrodes, using copper welding by thermit process.

Use mechanical connectors for grounding connections to equipment provided with lugs.

Soldered joints are not permitted.

Install bonding wire for flexible conduit, connected at both ends to grounding bushing, solderless lug, clamp or cup washer and screw. Neatly cleat bonding wire to exterior of flexible conduit.

Bond single conductor, metallic armoured cables to cabinet at supply end and provide non-metallic entry plate at load end.

**GENERAL PROVISIONS AND CONTRACT SPECIFICATIONS  
FOR HIGHWAY CONSTRUCTION**

DEPARTMENT OF TRANSPORTATION AND PUBLIC WORKS

---

**BASIC MATERIALS**

**1003**

Install grounding connections to service equipment.

1003.14.07     Tests of Grounding System

Perform grounding tests as required by the Electrical Inspection Division of the Department of Labour.

1003.14.08     Traffic Loop Sealant

Prepare joint surfaces, mix compounds and place sealant in accordance with manufacturer's instructions.

**GENERAL PROVISIONS AND CONTRACT SPECIFICATIONS  
FOR HIGHWAY CONSTRUCTION**

DEPARTMENT OF TRANSPORTATION AND PUBLIC WORKS

---

**TRAFFIC SIGNALS**

**1004**

---

1004.01

Description

Provide all labour, tools, equipment and materials necessary to complete the traffic control system.

Install the following equipment supplied by the Department:

- Traffic signals, heads and lamps
- Poles, brackets and trusses
- Traffic controller and flasher unit
- Mounting hardware
- Precast concrete pole bases available for pickup at the storage yard located on Riverside Drive, north of Queen Elizabeth Hospital

Supply and installation of the following:

- Concrete base for signal controller
- Conduits and junction boxes
- Vehicle detector loops
- System wiring including traffic signal cable, twisted and shielded lead-in cable, detector loop cable, beacon signal and power service wiring including fused disconnect switch

1004.02

Existing Underground Utilities

The intersection may contain underground telephone, street lighting, storm and sanitary sewer and water utilities. The location of these utilities as indicated on the Drawings shall be approximate only.

1004.03

Power Supply

Known utility pole locations are shown on the Drawings.

The Contractor shall co-ordinate the installation of traffic signal power supply with Maritime Electric.

1004.04

Material

Concrete and reinforcement shall be in accordance with Section 1101. Concrete mix for controller base and junction boxes to produce 32 MPa minimum compressive strength at 28 days.

Granular base material shall be in accordance with Section 401.

Anchor bolts shall be in accordance with Section 1101.

Conduit as shall be in accordance with Provision 1003.05.

**GENERAL PROVISIONS AND CONTRACT SPECIFICATIONS  
FOR HIGHWAY CONSTRUCTION**

DEPARTMENT OF TRANSPORTATION AND PUBLIC WORKS

---

**TRAFFIC SIGNALS**

**1004**

---

1004.05      Construction Method

1004.05.01    Excavation and Backfill

The Contractor shall excavate and backfill in accordance with Section 217.

1004.05.02    Bedding Material

The Contractor shall comply with the following procedure:

Place bedding material beneath signal bases and controller foundation to details indicated or as directed.

Shape bed true to grade to provide a uniform horizontal bearing surface for base structures.

Bedding material, in accordance with Section 220, shall be placed in 150 mm layers and compact 95% Standard Proctor Density in accordance with Section 209.

1004.05.03    Concrete

The Contractor shall comply with the following procedure:

Do concrete work in accordance with Section 1101.

Form vertical surfaces to full height using forming material that will not deform under loading by plastic concrete.

Accurately place reinforcing steel and anchor bolts in positions indicated and hold firmly during placing, compacting and setting of concrete.

Finish exposed surfaces to a smooth uniform finish, free of open texture and exposed aggregate.

Install precast concrete bases supplied by the Department where shown on the Drawings. Provide backfill in accordance with the respective specifications.

The grade on the top of the concrete base shall be a minimum of 25 mm and a maximum of 50 mm above the top of the adjacent curb, or, if no curb exists, above the finished grade of the surrounding material.

1004.05.04    Installation of Poles

The Contractor shall comply with the following procedure:

Prior to erection of the poles clean the under surfaces of all base plates and treat with a non-staining sealant.

Install poles with handhold facing away from the roadway.

Field drill apertures for installation of signal wiring from truss bracket. De-burr edges of holes and install rubber grommets.

**GENERAL PROVISIONS AND CONTRACT SPECIFICATIONS  
FOR HIGHWAY CONSTRUCTION**

DEPARTMENT OF TRANSPORTATION AND PUBLIC WORKS

---

**TRAFFIC SIGNALS**

**1004**

---

Secure poles in a vertical position.

Tighten all nuts to a ½ turn beyond snug tight condition ensuring that all parts of the joint are brought into full contact with each other and that all bolts are in tension.

Grout the space between the underside of the pole base and the top of the concrete base with approved non-metallic, non-shrink grout.

1004.05.05     Installation of Signal Brackets

The Contractor shall comply with the following procedure:

Install truss, side post and post top brackets in the positions shown on the Drawings.

Attach the brackets to the metal poles in the manner recommended by the manufacturer.

Slip-fit signal hangers onto the tenons of the truss brackets and secure in position.

1004.05.06     Installation of Signal Heads

The Contractor shall comply with the following procedure:

Orient signal heads as shown on the Drawings.

Secure signal heads in a horizontal or vertical alignment to the satisfaction of the Engineer.

Install lamps in signal head sockets with convex curvature of lamp filament facing down and filament supports in a horizontal plane.

Install 135 W lamps in all 300 mm signal heads.

Install 116 W lamps in all 200 mm signal heads.

Install 69 W lamps in all pedestrian signals.

1004.05.07     Installation of Conduit

The Contractor shall install conduit in the locations and to the details shown on the Drawings.

1004.05.08     Installation of Detector Loops

The Contractor shall comply with the following procedure:

Install loop wire continuous from curbside junction box around loop and back to junction box. Splices are not permitted.

Twist wires from loop to junction box. Use 18 turns per metre with equal lay on each wire.

**GENERAL PROVISIONS AND CONTRACT SPECIFICATIONS  
FOR HIGHWAY CONSTRUCTION**

DEPARTMENT OF TRANSPORTATION AND PUBLIC WORKS

---

**TRAFFIC SIGNALS**

**1004**

---

Splice loop leads to detector lead-in cable using scotchcast 85-10 3M splice kit or equivalent as approved by the Engineer.

Centre detector loop in the traffic lane to the dimensions shown on the Drawings. Install detector loops in a slot formed in the pavement to the details indicated on the Drawings.

To complete the loop connection extend one of the slots toward the curb. Twist the loop conductors where they enter the under-curb conduit sleeve and extend to the designated junction box as detailed on the Drawings.

Clean slots of loose material and moisture to the approval of the Engineer.

Exercise extreme care during installation to ensure that the loop turns are wound in 1 direction. Stack individual loop turns directly one above another. Prevent individual wires from twisting on themselves.

Install loops to following procedure:

- Apply 6 mm layer sealant to bottom of slot.
- Temperature control sealant to prevent burning of the wire insulation.
- After sealant has set sufficiently lay the first turn in the slot. Install wire slack to allow contraction.
- Apply additional sealant to fill slots on either side of the loop. Do not cover top of wire.
- Repeat preceding steps until all turns have been installed and sealant is applied to its final levels, 1.6 mm above finished road grade.
- Twist loop leads about one another - 18 twists per metre.
- Group and twist individual loop feeder pairs and extend through conduit sleeves under curb to junction box as indicated on the Drawing. Ensure conduit sleeve is packed with sealant before asphalt is laid. Connect each set of lane loops in series to the 2C twisted/shielded lead-in cable.
- Route copper lead-in cable via underground conduit to the traffic signal controller cabinet and connect to the detector harness as directed by the controller manufacturer.

Check the continuity, resistance to ground and insulation leakage at 500 V. Perform this check in the presence of the Engineer.

**GENERAL PROVISIONS AND CONTRACT SPECIFICATIONS  
FOR HIGHWAY CONSTRUCTION**

DEPARTMENT OF TRANSPORTATION AND PUBLIC WORKS

---

**TRAFFIC SIGNALS**

**1004**

---

1004.05.09     Installation of Traffic Signal Controller Cabinet

The Contractor shall comply with the following procedure:

Secure controller cabinet to the concrete base by use of chuck-end type anchors complete with stainless steel machine bolts and lock washers. The number and location of bolts to be as per the cabinet manufacturer's instructions.

Assemble and secure control equipment components within the cabinet.

Install beacon flasher unit on cabinet as indicated.

Bring traffic signal and detector lead-in cables and power supply and ground wire conductors into the cabinet and make connections as shown on the Drawings and in accordance with the manufacturer's instructions.

All wiring and connections shall be in accordance with Sections 1001 and 1003.

1004.05.10     Installation of Power Supply

The Contractor shall comply with the following procedure:

Install conduit risers on power supply pole as shown on the Drawings.

Install supply conductors in the conduits in a continuous run between the service entrance fitting and the controller.

Provide a minimum of 1.5 m of supply conductors coiled at the service entrance for final connection to the overhead supply by Maritime Electric.

All wiring to be in accordance with Sections 1001 and 1003.

1004.05.11     Installation of Traffic Signal Control Equipment

The Contractor shall comply with the following procedure:

Install controller only after all signal system and power feed wiring has been completed.

The signal system shall be energized and placed in the operating mode immediately after installation.

The control equipment is to be tested by operating the system for at least 1 hour in the presence of the Engineer prior to setting the system on "all flash" operation.

**GENERAL PROVISIONS AND CONTRACT SPECIFICATIONS  
FOR HIGHWAY CONSTRUCTION**

DEPARTMENT OF TRANSPORTATION AND PUBLIC WORKS

---

**TRAFFIC SIGNALS**

**1004**

1004.06      Testing and Commissioning

The Contractor shall comply with the following procedure:

Test the continuity, resistance to ground and insulation leakage of the detector loop.

Ensure that all signal heads are securely covered during periods when the signal system is not in operation.

1004.07      Method of Measurement

Measurement for payment under this Section shall be a unit measurement based on the completion of the traffic control system specified.

1004.08      Basis of Payment

Payment under this Section shall be at the unit bid price as a lump sum and this price shall be full compensation for the following:

- Excavation and backfill, disposal of surplus material, supply, placement and compaction of bedding material, concrete, reinforcing, grout and anchor bolts.
  
- The acceptance, transportation, and installation items supplied by the Department including traffic signal poles, bases and signal heads complete with truss brackets, spring cushion hangers, appurtenances and wiring, and the signal controller and flasher unit installed on the concrete base constructed by the Contractor, including ducts, bolts, wiring, cabinet, all connections and system testing.
  
- The supply and installation of junction boxes complete with conduit stubs, ground rods, frames and covers, ducts including timber planks, signal wiring, and connections, detector loops including saw cutting asphalt, sealant, connection of loop wiring to lead wires in junction box; and power supply including conduit, main disconnect, utility metre base, miscellaneous appurtenances, conductors and connection to utility.



**GENERAL PROVISIONS AND CONTRACT SPECIFICATIONS  
FOR HIGHWAY CONSTRUCTION**

DEPARTMENT OF TRANSPORTATION AND PUBLIC WORKS

---

**CONCRETE**

**1100**

- 1101 Cast-In-Place Concrete
- 1102 Curb and Gutter
- 1103 Concrete Sidewalk
- 1104 Precast Concrete Span

**GENERAL PROVISIONS AND CONTRACT SPECIFICATIONS  
FOR HIGHWAY CONSTRUCTION**

DEPARTMENT OF TRANSPORTATION AND PUBLIC WORKS

---

**CAST-IN-PLACE CONCRETE**

**1101**

1101.01

Description

This Section specifies requirements for constructing, supplying, transporting and placing cast-in-place concrete.

1101.02

Reference Standards

Cast-in-place concrete work shall be in accordance with CAN3-A23.1-M and testing shall be in accordance with CAN-A23.2-M except where otherwise specified.

1101.03

Samples

The Contractor shall inform the Engineer of proposed source of aggregates in advance of the work and shall provide access for sampling as requested.

1101.04

Certificates

The Contractor shall provide the following certification to the Engineer:

Prior to starting concrete work submit the manufacturer's test date and the certification by qualified independent inspection and testing laboratory that the materials will meet specified requirements.

Provide certification that plant, equipment, and materials to be used in the cast-in-place concrete work comply with requirements of CAN3-A23.1M.

Provide certification that mix proportions selected will produce concrete of specified quality and yield and that the strength will comply with CAN3-A23.1-M.

1101.05

Quality Control

The Contractor shall submit proposed quality control procedures for the Engineer's approval.

1101.06

Material

The Contractor shall supply and use only materials meeting the following standards:

Formwork lumber: plywood and wood formwork materials conforming to CAN3-A23.1-M.

Form release agent: Chemically active release agents containing compounds that react with free lime present in concrete to provide water insoluble soaps to prevent a film from setting on the forms.

Reinforcement shall be billet steel conforming to CSA G40.12, Grade 400, unless otherwise specified.

Chairs, bolsters, bar supports and spacers shall be of adequate strength to support reinforcing construction conditions.

Portland cement: to CAN3-A5, Type 10, except high-early strength cement, if permitted, shall be Type 30.

**GENERAL PROVISIONS AND CONTRACT SPECIFICATIONS  
FOR HIGHWAY CONSTRUCTION**

DEPARTMENT OF TRANSPORTATION AND PUBLIC WORKS

---

**CAST-IN-PLACE CONCRETE**

**1101**

Water: to CAN3-A23.1.

Aggregates: to CAN3-A23.1.M Course aggregates to be normal density.

Air entraining admixture: to CAN3-A266.1-M.

Chemical Admixtures: to CAN3-A266.2-M. Owner to approve accelerating or set retarding admixtures during cold and hot weather placing.

Supplementary cementing materials and their use: to CAN3-A23.5-M.

Non-shrinkgrout: premixed compound consisting of non-metallic aggregate, Portland cement, water reducing and plasticizing agents, of pouring consistency, capable of developing compressive strength of 30 MPa at 28 days.

Curing compound: to CAN3-A23.1-M white.

Bolts and anchor bolts to ASTM A-307.

Pre-moulded joint filler: bituminous impregnated fibreboard to ASTM D-1751.

Granular base as specified in Section 401.

Bedding sand as specified in Section 402.

1101.07

Reinforcing Fabrication

The Contractor shall comply with the following procedure:

Fabricate reinforcing to CAN3-A23.1-M.

Obtain Engineer's approval for locations of reinforcement splices.

Fabricate reinforcing steel within the following tolerances:

- Sheared length: plus or minus 25 mm.

Ship bundles of reinforcement bar, clearly identified in accordance with bar lists.

1101.08

Concrete Mixes

The Contractor shall comply with the following procedure:

Proportion normal density concrete in accordance with CAN3-A23.1, Alternative 1, for all concrete except a suspended slab at a manhole chamber, to give the following properties:

- Use type 10 cement.
- Minimum compressive strength at 28 days: 32 MPa.
- Minimum cement content: to CAN3-A23.1-M.
- Class of exposure: C-2.
- Nominal size of coarse aggregate: 20 mm.
- Slump at time and point of discharge: 80 mm ± 30 mm.

**GENERAL PROVISIONS AND CONTRACT SPECIFICATIONS  
FOR HIGHWAY CONSTRUCTION**

DEPARTMENT OF TRANSPORTATION AND PUBLIC WORKS

---

**CAST-IN-PLACE CONCRETE**

**1101**

- Air content: 5 to 8%.
- Maximum water-cement ratio 0.45.
- Chemical admixtures: to CAN3-A266.4M.

Proportion normal density concrete in accordance with CAN3-A23.1, Alternative 1, to give following properties for a suspended slab at a manhole chamber:

- Use type 10 cement.
- Minimum compressive strength at 28 days: 35 MPA.
- Minimum cement content: to CAN3-A23.1M.
- Class of exposure: C-1.
- Nominal size of coarse aggregate: 20 mm.
- Slump at time and point of discharge: 80 mm ± 30 mm.
- Air content: 5 to 8%.
- Maximum water-cement ratio: 0.40.
- Chemical admixtures: to CAN3-A266.4M.

Do not change concrete mix without prior approval of the Engineer. Should a change in material source be proposed, a new mix design shall be provided for approval by the Engineer.

1101.09

Workmanship

The Contractor shall comply with the following procedure:

Obtain Engineer's approval and provide 24 hours notice prior to concrete placement.

Pumping of concrete is permitted only after approval of equipment and mix.

Ensure reinforcement and inserts are not disturbed during concrete placement.

Maintain accurate records of poured concrete items to indicate date, location of pour, quality, air temperature and test samples taken.

Protect and cure concrete in extreme weather in accordance with CAN3-A23.1-M. Prior to concrete placement in adverse weather conditions obtain Engineer's approval of proposed method for protection of concrete during placing and curing.

Do not place concrete on frozen ground.

In locations where new concrete is dowelled to existing work, drill holes in existing concrete. Place dowels of deformed steel reinforcing bars as shown on the Drawings and pack solidly with non-shrink grout to positively position and anchor dowels.

Do not place load on new concrete until authorized by Engineer.

Control joints are to be a minimum of  $\frac{1}{4}$  and a maximum of  $\frac{1}{3}$  of the section thickness.

Saw cutting may be allowed if done as soon as concrete has set sufficiently to resist ravelling and before shrinkage cracks appear.

**GENERAL PROVISIONS AND CONTRACT SPECIFICATIONS  
FOR HIGHWAY CONSTRUCTION**

DEPARTMENT OF TRANSPORTATION AND PUBLIC WORKS

---

**CAST-IN-PLACE CONCRETE**

**1101**

Fill control joints with backer rods and sealant in accordance with manufacturer's recommendations.

Install isolation joint filler around manholes and catch basins and along the length adjacent to concrete curbs, catch basins or permanent structures.

Horizontal and vertical alignment of the forms shall be within 6 mm of the design location.

1101.10     Erecting Forms

The Contractor shall comply with the following procedure:

Verify lines and levels before proceeding with formwork and ensure that the dimensions agree with the Drawings.

Construct forms to produce finished concrete conforming to the shape, dimensions, locations and levels indicated within tolerances required by CAN3-A23.1-M.

Align form joints and make them watertight. Keep form joints to a minimum.

Leave formwork in place for a minimum of 6 days after placement during cold weather (5 °C ) or 2 days during normal weather (16 ° C).

Adequately shore and brace members subjected to additional loads during construction.

Assume full responsibility for any damage to the structure due to premature removal of forms.

1101.11     Placing Reinforcement

The placement and positioning of reinforcing steel shall conform with CAN3-A23.3.

All reinforcing shall be clean, free from mill scale, oil, grease or other matter before and after erection and shall be kept in a condition approved by the Engineer.

All reinforcing steel shall be secured rigidly in position by annealed iron wire or suitable clips at intersections and well supported on reinforcing chairs.

The Contractor shall ensure that the positions of the bars do not alter during concrete placement and that the cover as shown on the Contract drawings is maintained at all times.

The Contractor shall obtain the Engineer's approval of reinforcing steel quantities and placement before placing concrete.

1101.12     Inserts

The Contractor shall comply with the following procedure:

Set anchor bolts to templates under supervision of the appropriate trade prior to placing concrete.

**GENERAL PROVISIONS AND CONTRACT SPECIFICATIONS  
FOR HIGHWAY CONSTRUCTION**

DEPARTMENT OF TRANSPORTATION AND PUBLIC WORKS

---

**CAST-IN-PLACE CONCRETE**

**1101**

With Engineer's approval, grout anchor bolts in preformed holes or holes drilled after concrete has set. Formed holes are to be at least 100 mm in diameter. Drilled holes are to be a minimum of 25 mm larger in diameter than the bolts to be used.

Protect anchor bolt holes from water accumulations.

Set bolts and fill holes with non-shrink grout.

Set inserts and openings as indicated. Openings greater than (100 x 100 mm) not indicated on the Drawings must be approved by Engineer.

Do not eliminate or displace reinforcement to accommodate hardware. If inserts cannot be located as specified, obtain Engineer's approval for modifications before placing concrete.

1101.13 Finishing

The Contractor shall comply with the following procedure:

Finish concrete in accordance with CAN3-A23.1-M.

Finish exposed surfaces to a smooth uniform finish, free of open texture and exposed aggregate. Do not work more mortar to surface than required. Do not use neat cement as a dryer to facilitate finishing.

Trowel smooth the top surfaces of concrete foundations and bases.

Round edges, including edges of joints, with a 6 mm radius edging tool.

Finish surfaces to within 6 mm in 3 m, from lines, level or grade as measured with a straight edge placed on surface.

Apply curing compound to finished surfaces at a rate recommended by manufacturer.

Finish the perimeter of all slabs with an edger.

1101.14 Defective Work

Concrete shall be deemed defective when it contains excessive honeycombing, embedded debris or when the 28-day strength in any defined area is less than 95% of the specified strength.

1101.15 Method of Measurement

There shall be no measurement for payment under this section.

1101.16 Basis of Payment

No payment shall apply to this section. Cast-in-place concrete shall be supplied and paid for according to the various specifications for curb and gutter, sidewalk, or other bid items as specified.

**GENERAL PROVISIONS AND CONTRACT SPECIFICATIONS  
FOR HIGHWAY CONSTRUCTION**

DEPARTMENT OF TRANSPORTATION AND PUBLIC WORKS

---

**CURB AND GUTTER**

**1102**

---

1102.01

Description

This Section specifies requirements for constructing concrete curb and curb and gutter on granular base to lines, grades, dimensions and typical cross-sections indicated or directed.

1102.02

Materials

The Contractor shall supply and use only materials meeting the following standards:

Cast-in-place concrete and reinforcing shall be in accordance with Section 1101.

Concrete mix for cast-in-place concrete shall be designed to produce 32 MPa minimum compressive strength at 28 days and containing 20 mm maximum size, coarse aggregate. Water cement ratio by weight shall not exceed 0.45. The concrete shall have an air content of 5% to 8%. Class of exposure C-2.

Isolation joint filler: to ASTM D1751, 12 mm preformed, not-extruding, resilient, bituminous type.

Curing compound: to ASTM C309, Type 2, "Ritecure" as manufactured by Sternsons or MB-429 as manufactured by Master Builders.

Chemical grout: epoxy acrylate resin. Acceptable product: Hilti C-100.

Granular base under curb and gutter: Class 'A' gravel as specified in Section 1101.

1102.03

Construction Methods

The Contractor shall comply with the following procedure:

Construction of curb or curb and gutter shall be in accordance with Figures 1102.1, 1102.2, 1102.3 and 1102.4.

Do not place concrete until finished granular base is inspected and approved.

Place granular base material to lines, widths and depths indicated.

Compact granular base to minimum 100% Standard Proctor Density.

Concrete for curbs and curb and gutter to be shaped by forms of either wood or metal construction or by use of a slip form paver. Extruding equipment and mule configuration to be approved before construction begins.

Form vertical surfaces to full depth using forming material that will not deform under loading by plastic concrete.

Securely position forms to required lines and grades.

Horizontal and vertical alignment of the forms prior to placing concrete shall not vary more than 6 mm from the correct alignment and grade.

**GENERAL PROVISIONS AND CONTRACT SPECIFICATIONS  
FOR HIGHWAY CONSTRUCTION**

DEPARTMENT OF TRANSPORTATION AND PUBLIC WORKS

---

**CURB AND GUTTER**

**1102**

---

Coat forms with approved form release agent.

Obtain acceptance of forms before placing concrete.

Do concrete and reinforcing work in accordance with Section 1101 and as specified herein.

Finish exposed surfaces to a smooth uniform finish, free of open texturing and exposed aggregate. Do not work more mortar to surface than required. Do not use neat cement as a drier to facilitate finishing.

Round edges, including edges of joints, with 6 mm radius edging tool.

Finish surfaces to within 6 mm in 3 metres from line, level or grade as measured with a straight edge placed on surface.

Apply curing compound to finished surfaces at a rate recommended by manufacturer.

Control joints to be a minimum of  $\frac{1}{4}$  to a maximum of  $\frac{1}{3}$  of the section thickness.

Space control joints every 3 metres for curbs unless otherwise indicated.

Provide control joints within 150 mm of change in cross-section of curbs and gutters.

Finish perimeter of all slabs with an edger.

Saw cutting may be allowed if done as soon as concrete has set sufficiently to resist raveling and before shrinkage cracks appear.

When new curb is adjacent to sidewalks make joints of curb and sidewalk coincide.

Install isolation joint filler around manholes and catch basins and along length adjacent to concrete curbs, catch basins, or permanent structures.

1102.04 Method of Measurement

The quantity of curb and curb and gutter for which payment will be made shall be measured in linear metres constructed. Modified curb sections across driveways are to be included in the measurement.



**GENERAL PROVISIONS AND CONTRACT SPECIFICATIONS  
FOR HIGHWAY CONSTRUCTION**

DEPARTMENT OF TRANSPORTATION AND PUBLIC WORKS

---

**CURB AND GUTTER**

**1102**

1102.04

Basis of Payment

The unit bid price for each of these items shall be for the number of linear metres as measured by the method of measurement.

Such payment shall be full compensation for excavation and foundation preparation; supply, transporting and placing concrete, reinforcing and dowels, excavation and compaction of granular base, formwork, finishing, jointing and curing; and for all labour and other materials necessary to complete the work.

Backfill behind curbs shall be paid for in accordance with the section for the type of material supplied.

Granular base under curb and gutter shall be paid for under Section 207.

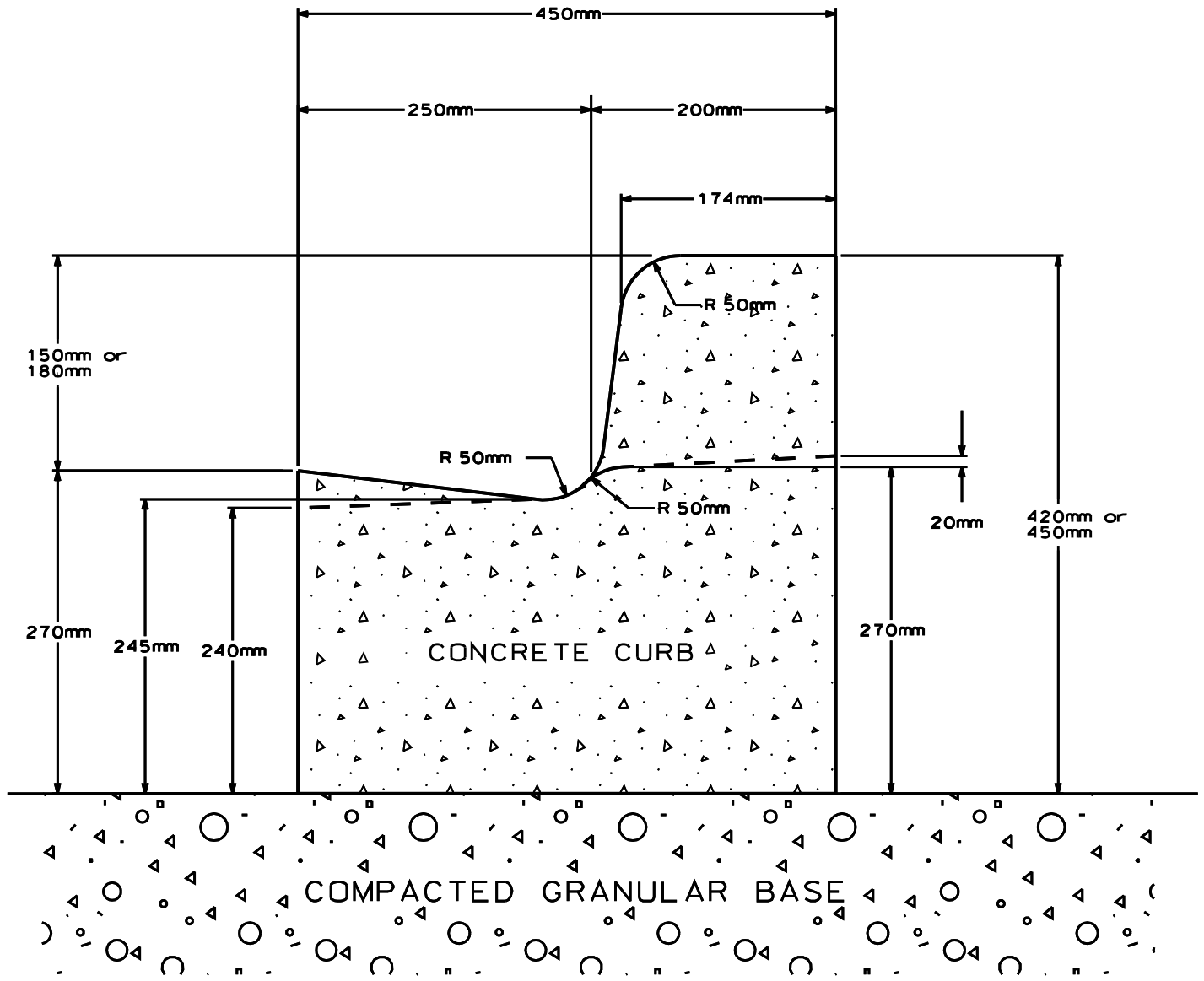

CROSS-SECTION (N.T.S.)

FIGURE 1102-01 CONCRETE CURB AND GUTTER ON GRANULAR BASE  
REVISED 2002

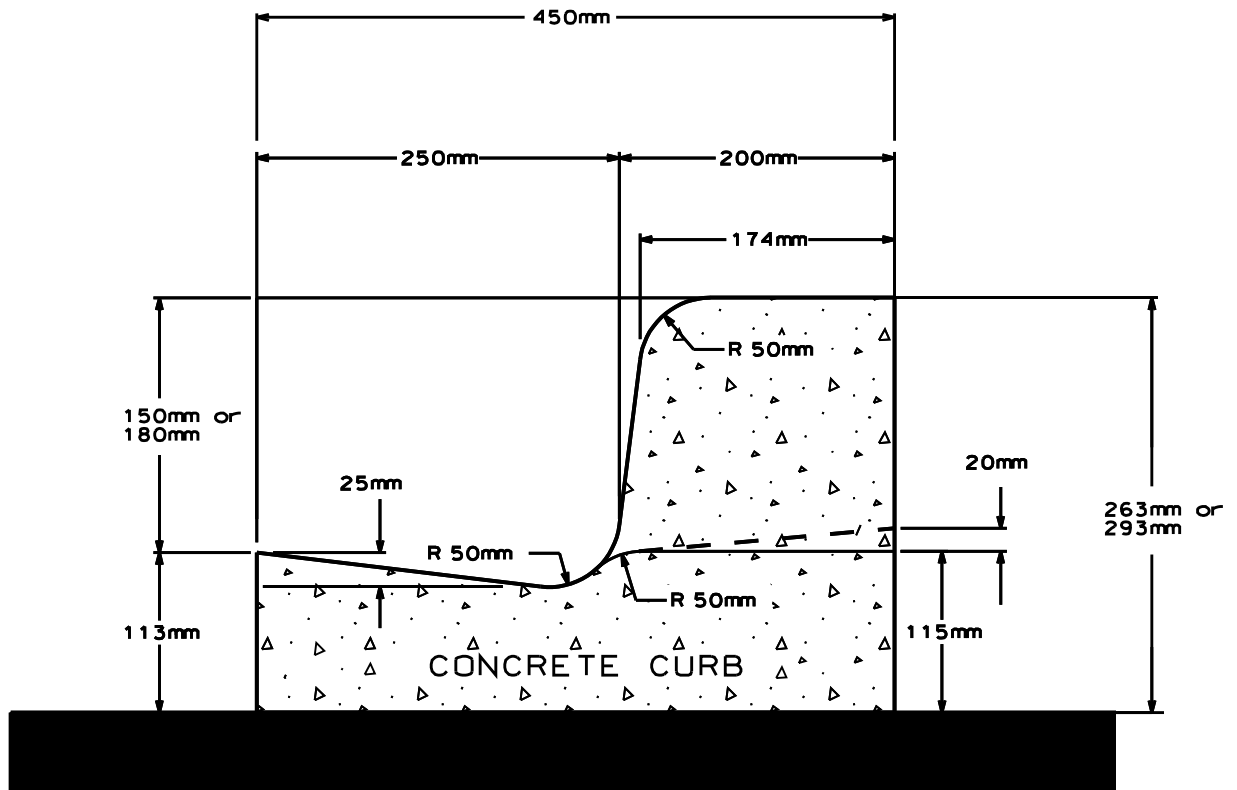

CROSS-SECTION (N.T.S.)

FIGURE 1102-02 CONCRETE CURB AND GUTTER ON ASPHALT BASE

REVISED 2002

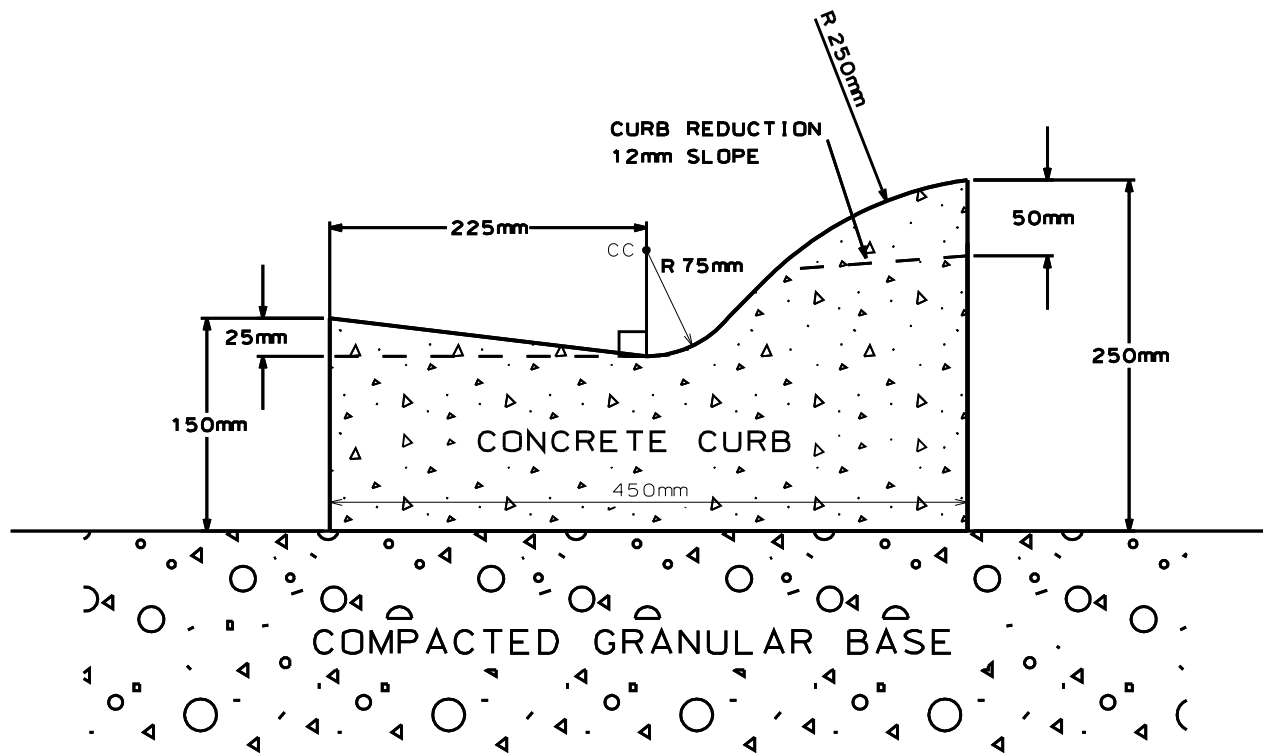

CROSS-SECTION (N.T.S.)

FIGURE 1102-03 SEMI-MOUNTABLE CURB AND GUTTER  
REVISED 2002

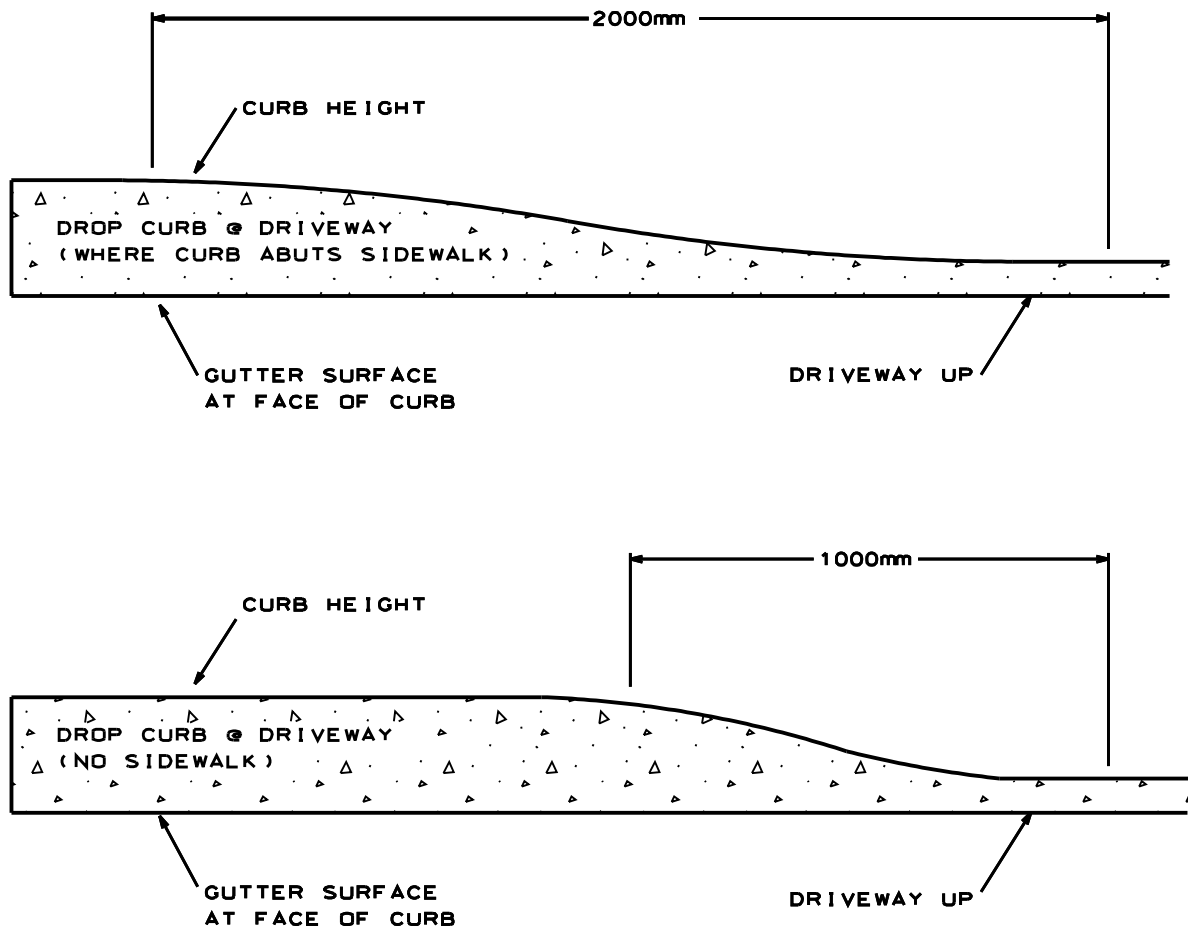

ELEVATIONS (N.T.S.)

**FIGURE 1102-04 TYPICAL CURB PROFILE DETAILS**  
**REVISED 2002**

**GENERAL PROVISIONS AND CONTRACT SPECIFICATIONS  
FOR HIGHWAY CONSTRUCTION**

DEPARTMENT OF TRANSPORTATION AND PUBLIC WORKS

---

**CONCRETE SIDEWALK**

**1103**

---

1103.01      Description

This Section specifies requirements for constructing concrete sidewalk on granular base to lines, grades, dimensions and typical cross-sections indicated or directed.

1103.02      Material

The Contractor shall supply and use only materials meeting the following standards:

Cast-in-place concrete shall be in accordance with Section 1101.

Concrete mix for cast-in-place concrete shall be designed to produce 32 MPa minimum compressive strength at 28 days and containing 20 mm maximum size, coarse aggregate. Water cement ration by weight shall not exceed 0.45. The concrete shall have an air content of 5% to 8%. Class of exposure C-2.

Isolation joint filler: to ASTM D1751, 12 mm preformed, non-extruding, resilient, bituminous type.

Curing compound: to ASTM C309, Type 2, "Ritecure" or equivalent.

Granular base under sidewalk: as specified in Section 1101.

Wire mesh Reinforcement: 150x150 MW18.7xMW18.7 welded wire fabric which meets the requirements of CSA G30.5-M.

1103.03      Construction Methods

1103.03.01      Preparation and Inspection

Construction of sidewalk shall be in accordance with Figures 1103.1 and 1103.2.

Do not place concrete until finished granular base is inspected and approved.

1103.03.02      Forming

The Contractor shall comply with the following procedure:

Concrete for sidewalk to be shaped by wood or metal forms.

Form vertical surfaces to full depth using forming material that will not deform under loading by plastic concrete.

Securely position forms to required lines and grades.

Horizontal and vertical alignment of the forms prior to placing concrete shall not vary more than 6 mm from the correct alignment and grade.

**GENERAL PROVISIONS AND CONTRACT SPECIFICATIONS  
FOR HIGHWAY CONSTRUCTION**

DEPARTMENT OF TRANSPORTATION AND PUBLIC WORKS

---

**CONCRETE SIDEWALK**

**1103**

---

Coat forms with approved form release agent.

Obtain acceptance of forms before placing concrete.

Slip-form paving machines may be used for placing concrete sidewalk but only in areas approved by the Engineer. The machine shall have automatic grade and line control and be able to spread, vibrate, shape and finish the concrete in a single pass while producing a dense and homogenous concrete section.

1103.03.03     Concrete

The Contractor shall comply with the following procedure:

Do concrete and reinforcing work in accordance with Section 1101.

Finish exposed surfaces to a smooth uniform finish, free of open texturing and exposed aggregate. Do not work more mortar to surface than required. Do not use neat cement as a drier to facilitate finishing. Broom finish sidewalk, transverse to the direction of traffic, to provide a non-skid, uniform texture.

Finish perimeter of all slabs with an edger.

Round edges, including edges of joints, with 6 mm radius edging tool.

Finish surfaces to within 6 mm in 3 metres from line, level or grade as measured with a straight edge placed on surface.

Apply curing compound to finished surfaces at a rate recommended by manufacturer.

1103.03.04     Jointing

The Contractor shall comply with the following procedure:

Control joints to be a minimum of one-quarter to a maximum of one-third of the section thickness.

Provide control joints within 150 mm of change in cross-section of curbs and gutters.

Saw cutting may be allowed if done as soon as concrete has set sufficiently to resist ravelling and before shrinkage cracks appear.

Install joints at intervals of:

- 7.5 metres for isolation joints
- 1.5 metres for transverse control joints

or as directed by the Project Engineer.

**GENERAL PROVISIONS AND CONTRACT SPECIFICATIONS  
FOR HIGHWAY CONSTRUCTION**

DEPARTMENT OF TRANSPORTATION AND PUBLIC WORKS

---

**CONCRETE SIDEWALK**

**1103**

---

Isolation joints shall be installed around manholes and catch basins and along length adjacent to concrete curbs, catch basins, and permanent structures.

1103.04      Measure of Measurement

The quantity of sidewalk for which payment will be made shall be measured in square metres.

1103.05      Basis of Payment

The unit bid price for these items shall be for the number of square metres of sidewalk as measured by the method of measurement.

Such payment shall be full compensation for excavation and foundation preparation; supplying, transporting and placing concrete, formwork, wire mesh reinforcement, finishing, jointing and curing; surface reinstatement (unless otherwise specified); cutting concrete curb for wheel chair ramps and for all labour and materials necessary to complete the work.

Backfill behind sidewalk shall be paid for in accordance with the section for the type of material supplied.

Granular base under sidewalk shall be paid under Section 220.



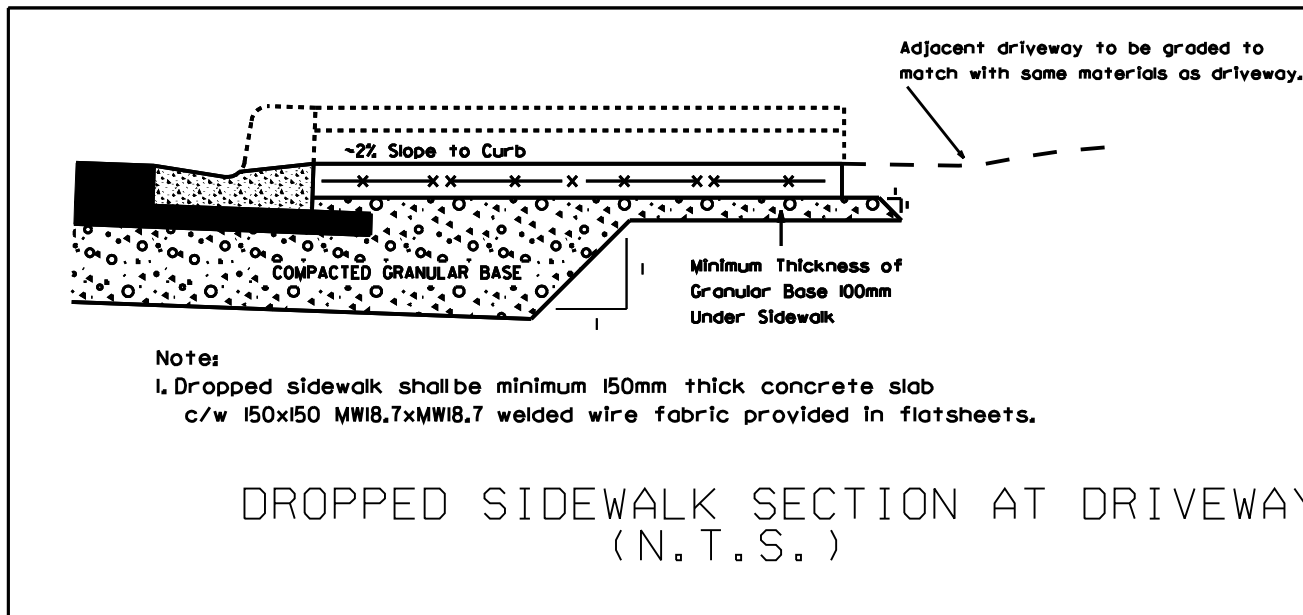
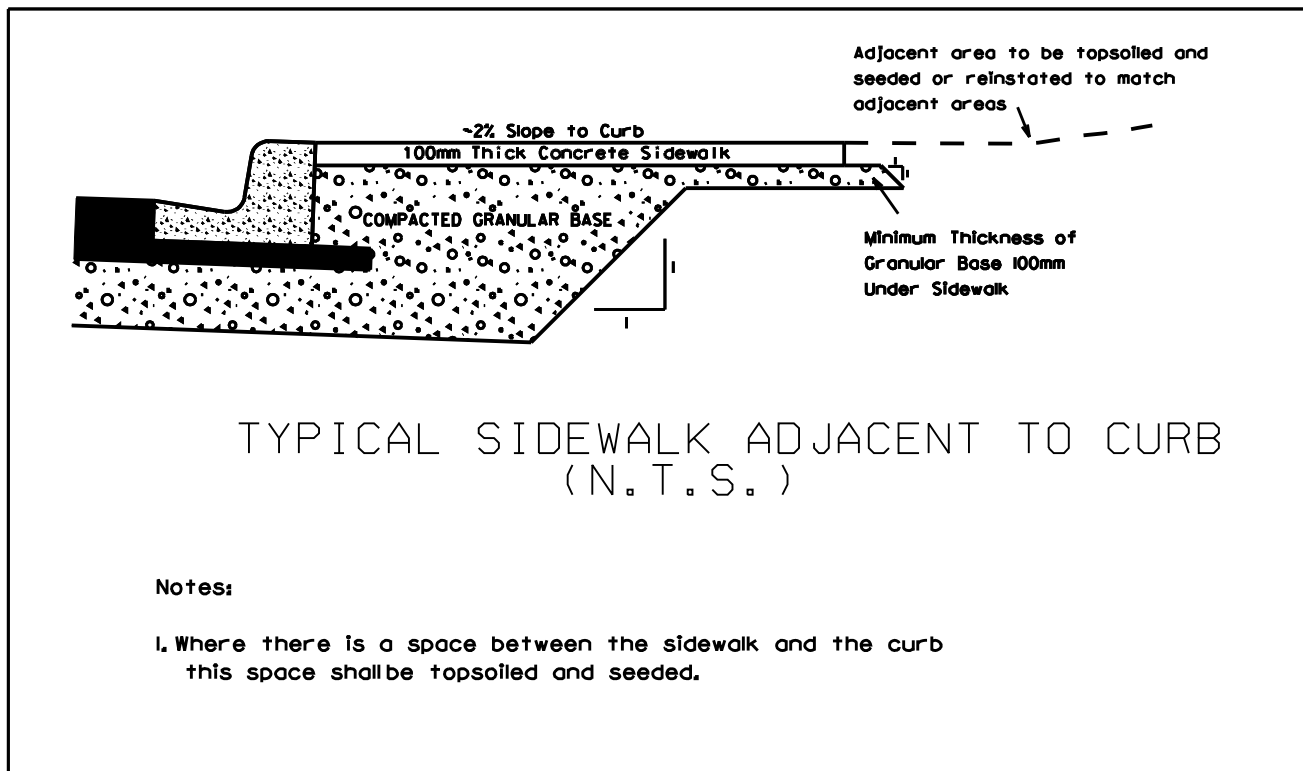
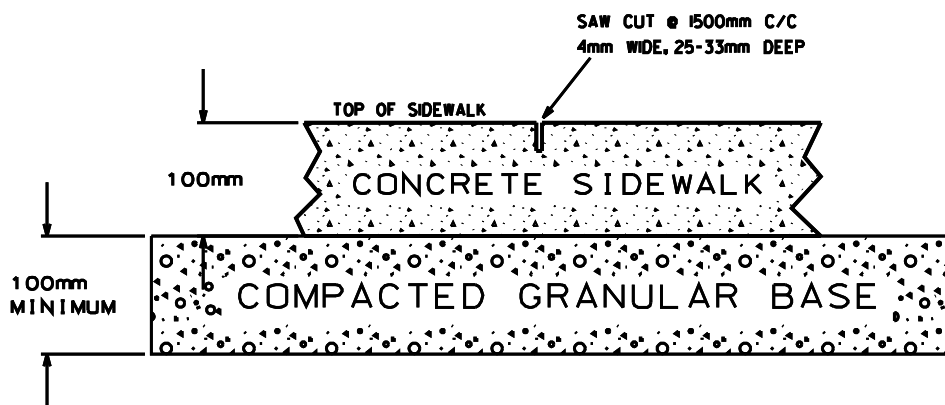

FIGURE 1103-01 SIDEWALK SECTIONS  
REVISED 2005



DETAIL - TYPICAL CONTROL  
JOINT IN SIDEWALK  
(N.T.S.)

FIGURE 1103-02 TYPICAL CONTROL JOINT IN SIDEWALK  
REVISED 2001

**GENERAL PROVISIONS AND CONTRACT SPECIFICATIONS  
FOR HIGHWAY CONSTRUCTION**

DEPARTMENT OF TRANSPORTATION AND PUBLIC WORKS

---

**PRECAST CONCRETE SPAN**

**1104**

1104.01      Description

This section specifies requirements for the design, manufacture, delivery and installation of precast concrete spans.

1104.02      Material

Concrete shall be in compliance with CSA CAN3-A23.1 and shall have a compressive strength of 35 MPa at 28 days.

Reinforcing steel shall either be wire fabric in compliance with CAN/CSA G30.5 - Grade 450 or be high strength deformed round bars in compliance with CSA G30.12 - Grade 400.

Joint water proofing and recommended primer shall be Rub'r Nek joint waterproofing or an equivalent approved by the Engineer.

1104.03      Construction Methods

1104.03.01      Design and Manufacturing

The manufacture of precast concrete spans shall not commence until the shop drawings have been approved by the department and have been stamped by a Professional Engineer licensed to practice in Prince Edward Island. Approval of shop drawings by the department will not relieve the manufacturer of the responsibility for correctness of dimensions, size of components and details of fabrication in accordance with the latest editions of AASHTO Standard Specifications for Highway Bridges, CSA CANS-A23.3 Design of Concrete Structures and CAN/CSA-S6 Design of Highway Bridges.

Curing shall conform to CSA A23.1-94. All sections should be covered for a minimum period of three consecutive days or spread with a curing agent.

The manufacturer will be responsible for all labour laws, patents and licensing fees, duties and handling charges, transportation and all other charges.

The manufacturer will ensure that each section will have a quality assurance document as specified in CSA A251. Mill certificates, concrete mix design and other Quality Assurance documents shall be prepared in binder format and delivered to the department on completion of the contract.

**GENERAL PROVISIONS AND CONTRACT SPECIFICATIONS  
FOR HIGHWAY CONSTRUCTION**

DEPARTMENT OF TRANSPORTATION AND PUBLIC WORKS

---

**PRECAST CONCRETE SPAN**

**1104**

1104.03.02     Inspection

The department shall have the right to inspect the manufacture of the precast concrete span and the authority to order production to stop if the work does not conform to plans, shop drawings or specifications. The manufacturer shall notify the department five calendar days in advance of the commencement of any phase of manufacturing.

To ensure proper jointing of sections to a maximum of 10 mm gap when installed at the job site, the manufacturer shall fit a random number of three sections at the factory.

Each span and footing section shall have the lot number, date of manufacture, name of manufacturer and specification designation marked on them by indentation or waterproof paint.

1104.03.03     Delivery to Site

It is the responsibility of the contractor to deliver the concrete span to the site safely and by the time specified in the contract.

1104.03.04     Placement

It is the responsibility of the contractor to properly place the concrete span and footings to the design criteria indicated by the project engineer.

1104.04         Method of Measurement

Measurement for payment under this Section shall be the number of linear metres of precast concrete span installed.

1104.05         Basis of Payment

Payment under this section shall be at the unit bid price per linear metre of precast concrete span and is to include all applicable taxes. This price shall be full compensation for all the work including, the supply and placement of footings, the supply and placement of the concrete span, transportation, equipment, tools, labour, curing, grouting, waterproofing, joint-filling, reinforcing steel and incidentals necessary to complete the work.

**GENERAL PROVISIONS AND CONTRACT SPECIFICATIONS  
FOR HIGHWAY CONSTRUCTION**

DEPARTMENT OF TRANSPORTATION AND PUBLIC WORKS

---

**MISCELLANEOUS**

**1200**

1201 Chain Link Fence and Gates

1202 Cash Allowance

**GENERAL PROVISIONS AND CONTRACT SPECIFICATIONS  
FOR HIGHWAY CONSTRUCTION**

DEPARTMENT OF TRANSPORTATION AND PUBLIC WORKS

---

**CHAIN LINK FENCE AND GATES**

**1201**

1201.01      Description

This work includes the supply, transportation and erection of chain link fences and gates.

1201.02      Reference Standards

CAN/CSA-23.1 Concrete Materials and Methods of Concrete Construction  
CAN/CGSB-138.1 Fence, Chain Link, Fabric  
CAN/CGSB-138.2 Fence, Chain Link, Framework, Zinc-Coated Steel  
CAN/CGSB-138.3 Fence, Chain Link, Installation  
CAN/CGSB-138.4 Fence, Chain Link, Gates  
CAN/CGSB-1-GP-181M Organic Zinc Rich Coating

1201.03      Shop Drawings

Shop Drawings are to show details of the work and are to indicate dimensions, materials, finish, fittings and hardware, installation requirements and other pertinent information.

Check all shop drawings prior to submission. Determine and verify all field measurements, field construction criteria, materials and similar data and check and coordinate each shop drawing with the requirements of the work. Sign and date each shop drawing to confirm compliance with Provision 1201.02.

Submit 6 copies of the shop drawings to the Engineer for review.

Engineer will not review shop drawings if it is evident that they are not in accordance with Provision 1201.02.

After review, the Engineer will return 4 copies of shop drawings. The Contractor shall make all corrections as noted and resubmit.

Do not proceed with work involving relevant products until completion of shop drawings.

1201.04      Material

1201.04.01 Concrete mixes and materials: to CAN/CSA-23.1. Nominal coarse aggregate size to be 20 mm. Compressive strength: 20 MPa minimum at 28 days.

1201.04.02 Chain link fence fabric: to CAN/CGSB-138.1. 9 Gauge, Type 1, Class A, heavy style. Height of Fabric: 2.4m or as indicated on the drawings.

1201.04.03 Posts, braces and rails to: CAN/CGSB-138.2, galvanized steel pipe, dimensions as follows:

Line Posts: 60mm diameter schedule 40 hot dipped galvanized tubular steel pipe.

Terminal Posts: 90mm diameter schedule 40 hot dipped galvanized tubular steel pipe, with stretching bands and bars for attaching fabric to the post. Terminal posts at double gate openings greater than 6m in width shall be 114mm diameter.

Top Rails: 43mm diameter schedule 40 hot dipped galvanized tubular steel pipe.

**GENERAL PROVISIONS AND CONTRACT SPECIFICATIONS  
FOR HIGHWAY CONSTRUCTION**

DEPARTMENT OF TRANSPORTATION AND PUBLIC WORKS

---

**CHAIN LINK FENCE AND GATES**

**1201**

- Braces: Gate, corner, straining and end posts shall be braced by a centre rail of the same material as the top rail, between the gate, corner or end post and the next post.
- 1201.04.04 Bottom tension wire: single strand, galvanized steel wire, 5 mm diameter.
- 1201.04.05 Tie wire fasteners: single strand, aluminum coated or galvanized steel wire conforming to requirements of fence fabric, 5 mm diameter.
- 1201.04.06 Tension bars: Min. (5 X 20 mm) galvanized steel.
- 1201.04.07 Tension bar bands: Min. (3 X 20 mm) galvanized steel or Min. (5 X 20 mm) aluminum.
- 1201.04.08 Gate frames: to ASTM A-53, galvanized steel pipe, standard weight 42.9 mm outside diameter pipe for outside frame, 33.3 mm outside diameter pipe for interior bracing.
- Fabricate gates as indicated with electrically welded joints and hot dipped galvanized after welding or paint gates with minimum 2 coats of zinc rich coating after welding.
- Fasten fence fabric to gate with twisted selvage at top.
- Furnish gates with galvanized malleable iron hinges, latch and latch catch with provision for a padlock which can be attached and operated from either side of installed gate.
- Furnish double gates with chain hook to hold gates open, and a centre rest with a drop bolt to hold gates closed.
- 1201.04.09 Fittings and hardware: cast aluminum alloy, galvanized steel or malleable or ductile cast iron. Post caps to provide waterproof fit, to fasten securely over posts and to carry top rail. Extension arms to provide waterproof fit, to hold top rails and an outward or inward projection, as directed and to hold barbed wire overhang. Provide projection with clips or recesses to hold 3 strands of barbed wire spaced 100 mm apart. Projection length of approximately 300 mm long to project from fence at 45° above horizontal. Turnbuckles to be drop forged.
- 1201.04.10 Organic zinc rich coating: to CGSB 1-GP-181M.
- 1201.04.11 Barbed wire: 2 mm diameter galvanized steel wire to ASTM A-121, 4 point barbs, 125 mm spacing.
- 1201.05 Finishes
- Galvanizing for chain link fabric: to CAN/CGSB-138.1 Grade 2.  
Galvanizing for pipe: 550 g/m<sup>2</sup> minimum to ASTM A-90.
- Galvanizing for barbed wire: to ASTM A-121, Class 2.
- Galvanizing for other fittings: to CSA G164.

**GENERAL PROVISIONS AND CONTRACT SPECIFICATIONS  
FOR HIGHWAY CONSTRUCTION**

DEPARTMENT OF TRANSPORTATION AND PUBLIC WORKS

---

**CHAIN LINK FENCE AND GATES**

**1201**

---

1201.06      Construction Method

1201.06.01      Grading

Remove debris and correct ground undulations along fence line to obtain smooth uniform gradient between posts. Provide a clearance between bottom of fence and ground surface no more than 75 mm.

1201.06.02      Erection of Fence

Erect fence along lines as directed by Engineer and in accordance with CAN/CGSB-138.3

Excavate post holes to 1500 mm depth x 300mm diameter or to dimensions as indicated by methods approved by Engineer.

Space line posts 2.4m apart as measured parallel to the ground surface or to spacing as indicated.

Space straining posts at equal intervals not exceeding 150 m if distance between end or corner posts on straight continuous lengths of fence, over reasonably smooth grade, is greater than 150 m.

Install additional straining posts at sharp changes in grade and where directed by Engineer.

Install corner post where change in alignment exceeds 10°.

Install end posts at end of fence and at buildings. Install gate posts on both sides of gate openings.

Place concrete in post holes then embed posts in concrete to depths as indicated on the Drawings. Extend concrete 50 mm above ground level and slope it to drain away from the posts. Brace to hold posts in plumb position, true to alignment and elevation until concrete has set.

Do not install fence fabric until concrete has cured a minimum of 5 days.

Install brace between end and gate posts and nearest line post, place in centre of panel and parallel to ground surface. Install braces on both sides of corner and straining posts in similar manner as required.

Install overhang tops and caps.

Install top rail between posts and fasten securely to terminal posts and secure waterproof caps and overhang tops.

Install bottom tension wire, stretch tightly and fasten securely to end, corner, gate and straining posts with turnbuckles and tension bar bands.

Lay out fence fabric. Stretch tightly to tension recommended by manufacturer and fasten to end, corner, gate and straining posts with the tension bar secured to post and with tension bar bands spaced at 300 mm intervals. Knuckled selvedge at bottom. Twisted selvedge at top.



**GENERAL PROVISIONS AND CONTRACT SPECIFICATIONS  
FOR HIGHWAY CONSTRUCTION**

DEPARTMENT OF TRANSPORTATION AND PUBLIC WORKS

---

**CHAIN LINK FENCE AND GATES**

**1201**

Secure fabric to top rails, line posts and bottom tension wire with tie wires at 450 mm intervals. Give tie wires two twists.

Install barbed wire strands and clip securely to lugs of each bracket.

1201.06.03     Installation of Gates

Install gates in locations where directed by Engineer.

Level contours between gate posts and set gate bottom approximately 40 mm above ground surface.

Determine position of centre gate rest for double gate. Cast gate rest in concrete as directed. Dome concrete above ground level to shed water.

Install gate stops where directed.

1201.06.04     Touch-up

Clean damaged surfaces with wire brush removing loose and cracked coatings. Apply 2 coats of organic zinc-rich paint to damaged areas. Pre-treat damaged surfaces according to manufacturers' instructions for zinc-rich paint.

1201.06.05     Cleaning

Clean and trim areas disturbed by operations. Dispose of surplus material and reinstate disturbed surfaces as directed by Engineer.

1201.07         Method of Measurement

Measurement for payment under this Section shall be the number of linear metres of chain link fence including gates installed.

1201.08         Basis of Payment

Payment shall be at the unit bid price per linear metre and this price shall be full compensation for supply, transportation, handling, storage and all labour, tools and materials necessary to complete the work.

**GENERAL PROVISIONS AND CONTRACT SPECIFICATIONS  
FOR HIGHWAY CONSTRUCTION**

DEPARTMENT OF TRANSPORTATION AND PUBLIC WORKS

---

**CASH ALLOWANCE**

**1202**

1202.01

Scope

This Section specifies the requirements for various items which shall be paid for by the Department under a cash allowance item.

1202.02

Reference Items

Items requested by the Department that are not obvious at the time of Tender, or other items as the Department may require included in the work.

In particular, telephone and service charges associated with the provision of the Engineers field office shall be provided for under this Section.

All cash allowances must be authorized by the Engineer.

1202.03

Basis of Payment

The Contractor shall be authorized to include 10% overhead to each invoice presented for payment under this Section.

**GENERAL PROVISIONS AND CONTRACT SPECIFICATIONS  
FOR HIGHWAY CONSTRUCTION**

DEPARTMENT OF TRANSPORTATION AND PUBLIC WORKS

---

**SUPPLEMENTAL SPECIFICATIONS**

**1300**

---

## **APPENDIX 1**

### **SAMPLE TENDER DOCUMENT**

Department of Transportation and Public Works  
Province of Prince Edward Island

**DEPARTMENT OF TRANSPORTATION AND PUBLIC WORKS  
Province of Prince Edward Island**

**TENDER FORM AND AGREEMENT  
Revision 0**

**THIS AGREEMENT** made by and between ....., herein called the Contractor, the Party of the First Part and The Government of Prince Edward Island as represented by the Honourable ....., herein called the Minister, the Party of the Second Part.

**WITNESS, AS FOLLOWS:**

**1. Definitions**

The definition of terms used in this Tender Form and Agreement shall conform in all respects to the definition of terms contained in the document entitled "General Provisions and Contract Specifications for Highway Construction," published by the Department of Transportation and Public Works of the Province of Prince Edward Island as amended on the date of closing of Tenders pursuant to this Agreement.

**2. General Covenant**

The contractor hereby covenants and agrees with the Minister as herein provided in connection with the following work, namely:

---

---

---

**3. No Implied Contract**

It is hereby understood and agreed between the parties hereto that no implied contract of any kind whatsoever, by, or on behalf, of the Minister shall arise or be implied from anything contained in this Contract, or from any position or situation of the parties at any time, and that this Contract made by the Minister is, and shall be, the only Contract upon which any rights against the Minister are to be founded.

**4. How Party of the First Part is Read**

Whenever this agreement is entered into by more than one party or parties of the first part, the word "Contractor" shall be read "Contractors," and pronouns in the contract referring to the Contractors shall be read as plural and whenever a corporation is the Party of the First Part, the said pronouns shall be read accordingly.

**5. Consideration of Clauses as Covenants**

Wherever it is stipulated that anything shall be done or performed by either of the Parties hereto, it shall have the same effect and be constructed as if such Party had entered into a covenant with the other Party to do or perform the same, and as if such covenant had been expressly made on the part of the Contractor, not only on the Contractor's own behalf, but also on the behalf of the Contractor's legal representative, successors or assigns; and as if any such covenant on the part of the Minister has been made on behalf of the Minister, and the Minister's successors in office.

**6. Contractors Submission Respecting the Agreement**

The Contractor shall, as part of the Contractor's submission respecting this agreement, complete the attached Schedule B, Identification of Principles, Schedule C, Schedule of Tendered Unit Prices, Schedule D, Schedule of Equipment to be used on the work, and Schedule E, Schedule of Subcontractors.

The agreement including all appended schedules shall be completed in complete conformity with the instructions to bidders contained in the document entitled "General Provisions and Contract Specification for Highway Construction."

In presenting the Contractors submission for consideration by the Minister, the Contractor understands that until, and unless, the agreement is endorsed by the Minister, no agreement between the parties shall exist and the Minister shall not be bound to endorse any agreement.

**7. Performance by Contractor**

The Contractor, at the Contractor's own expense, shall, except as herein otherwise specifically provided, furnish and provide all and every kind of labour and superintendence, services, tools, implements, machinery, plant materials, articles and whatsoever is necessary for the due execution of the work. The Contractor shall fully construct and erect the work in the most thorough, professional and substantial manner, in every respect to the satisfaction and approval of the Engineer. The Contractors shall complete the work within the time specified herein and deliver it to the Minister in the manner and upon the terms and conditions of the Contract.

**8. Bid and Performance Security**

The Contractors hereby and herewith deposits with and delivers to the Minister, as security of the due fulfilment of the Contract, one of the following, which shall remain in effect for a minimum of 30 days after Tender Closing:

- a) a certified cheque in the amount of ten percent ( 10% ) of the Tender Value, excluding GST.

OR

- b) a Bid Format irrevocable standby letter of credit on a Government approved form in the amount of ten percent ( 10% ) of the Tender Value, excluding GST.

OR

**INSERT NAME OF TENDER**

**Page 3**

**Rev. 0**

- c) a bid bond in the amount of ten percent ( 10% ) of the Tender Value, excluding GST. The bond shall be from a surety company authorized to carry on business in Canada guaranteeing to supply a performance bond equal to 50% of the Contract Value, excluding GST and a labour and material bond equal to 25% of the Contract Value, excluding GST.

Performance Security which shall be held and retained by the Minister as security for the due and faithful performance, observance and fulfilment by the Contractor of all the covenants, provisos, agreements, conditions and reservations in this Contract contained on the part of the Contractors to be observed, performed and complied with shall be in the form of:

- d) a certified cheque in the amount of ten percent ( 10% ) of the Contract Value, excluding GST, which shall be retained until Substantial Completion of the Contract.

OR

- e) a Performance Format irrevocable standby letter of credit on a Government approved form in the amount of ten percent ( 10% ) of the Contract Value, excluding GST, which shall be retained until November 30<sup>th</sup> in the year of the Contract or until Substantial Completion.

OR

- f) a performance bond equal to 50% of the Contract Value, excluding GST and a labour and materials bond equal to 25% of the Contract Value, excluding GST which shall be retained until the warranty period of one (1) year has elapsed.

The bidder will forfeit security to the Minister if the bidder fails to enter into or carry out the contract when called upon to do so.

It is understood and agreed that the Contractor assumes risk and must bear any loss in respect to the performance security as aforesaid, occasioned by the failure or insolvency of the banks on which any cheque was drawn or in which any deposit was made in connection with the security aforesaid.

If at any time hereafter the said Contractor should make default under the said Contract, or if the Minister acting under the powers reserved in the said Contract shall determine that the said works, or any portion thereof remaining to be done, should be taken out of the hands of the Contractor and be completed in any manner or way whatsoever than by the Contractor, or if the Contractor refuses or neglects to pay for work done or materials supplied by any person in connection with the said work, the Minister may, in either case dispose of said security for the carrying out of the construction and completion of the work of the Contract or for paying any salaries or wages for work done, or any accounts for materials supplied for the said works that may be left unpaid by the said Contractor.

In the event of any breach, default or non-performance being made or suffered by the Contractor in or in respect of any of the terms and conditions, covenants, provisions, agreements, or restrictions herein contained, which on the part of the said Contractor should be observed, performed or complied with, the said security so delivered to or deposited with the Minister or by the Minister received in respect thereof, shall by the contractor, be forfeited absolutely to the Minister.

Upon the due and faithful performance, observance and fulfilment by the Contractor of all the terms, provisions, covenants, agreements, conditions, reservations, hereinbefore contained, on the part of the Contractors to be observed, performed and complied with, the Minister shall surrender the performance security.

**9. Minister Covenants to Pay**

In consideration of the faithful performance by the Contractor of all and singular covenants, agreements and provisions of the Contract, the Minister hereby covenants and agrees with the Contractor that, on the full completion by the Contractor of all the work as specified in the Contract, within the time specified and limited for the final completion thereof, and to the entire satisfaction of the Engineer to be evidenced by the certificate of the Engineer in writing, the said Minister will well and truly pay, or cause to be paid, to the said Contractor the amount of the Contract price, representing the actual quantities in the several items in the Schedule of Prices, identified as Schedule C to this agreement, at the unit prices or lump sum prices quoted by the Contractor. This amount paid to the Contractor as above, shall include all and every kind of work, labour, superintendence, services, tools, implements, machinery, plant materials, articles and things whatsoever necessary for the full execution and completion of the work to the entire satisfaction of the Engineer.

**10. Final Payment**

It is hereby agreed by the parties hereto that the payment of the final amount due under the Contract, and the adjustment and payment of any bills that may be rendered for work done, in accordance with any alteration in or addition to the same, shall release the Minister from any and all claims or liability on account of work performed under the said Contract or any alteration in or addition to the same.

**11. No Waiver**

It is hereby agreed that no condoning, excusing, or overlooking by the Minister, or any person acting on the Minister's behalf on previous occasions of breaches or defaults similar to that for which any action is taken or power is exercised, or forfeiture is claimed or enforced against the Contractor, shall be taken as a waiver of any provisions of the Contract, or as defeating, affecting or prejudicing in any way the right of the Minister under the Contract.

**12. Components of the Contract**

Any and all plans or drawings prepared by the Department, the document titled General Provisions and Contract Specifications for Highway Construction, the advertisement, the Tender Form and Agreement together with Schedule A, Schedule of Special Provisions, Schedule B, Identification of Principals, Schedule C, Schedule of Tendered Unit Prices, Schedule D, Schedule of Equipment, and Schedule E, Schedule of Sub-Contractors, as well as any addenda which may be issued by the Department pursuant to this Contract shall hereby be a part of this Agreement as fully and to the same effect as if the same had been set forth at length in the body of the agreement.

**13. Completion of Work**

The Contractor agrees to complete the work on, or before the [DATE] of [MONTH], 200X.

**14. FOIPP Clause**



**INSERT NAME OF TENDER**

**Page 5**

**Rev. 0**

1. By submitting your bid, you agree to disclosure of the information supplied, subject to the provisions of the Freedom of Information and Protection of Privacy Act (FOIPP).
2. Anything submitted in your bid that you consider to be "confidential information" because of its proprietary nature should be marked as "confidential" and will be subject to appropriate consideration under the Freedom of Information and Protection of Privacy Act.
3. During the delivery and installation of goods and/or services, you may have access to confidential or personal information. Should this occur, you must ensure that such information is not released to any third party or unauthorized individual.
4. Any information provided on this contract may be subject to release under the Freedom of Information and Protection of Privacy Act. You will be consulted prior to the release of any information.

**INSERT NAME OF TENDER**

**Page 6**

**Rev. 0**

**IN WITNESS WHEREOF** the parties hereto have hereby caused these presents to be signed and sealed on the dates stated.

SIGNED, SEALED AND DELIVERED  
by the Contractor on the [     ] day  
of [                             ], 20[     ].

SIGNED, SEALED AND DELIVERED  
by the Minister on the [     ] day  
of [                             ], 20[     ].

.....  
CONTRACTOR

.....  
MINISTER

In the presence of:

In the presence of:

.....

.....

**SCHEDULE A  
SCHEDULE OF SPECIAL PROVISIONS**

**INSERT NAME OF TENDER**

**Page 1 of X**

**SCHEDULE B  
IDENTIFICATION OF PRINCIPALS**

**INSERT NAME OF TENDER**

**Name of Contractor:**

**Mailing Address:**

**Principal's Name:**

**Title:**

**Mailing Address:**

**If Contractor is a corporation in which province of Canada is the corporation registered:**

---

**SCHEDULE C  
SCHEDULE OF PRICES**

**INSERT NAME OF TENDER**

**SCHEDULE D  
SCHEDULE OF EQUIPMENT TO BE USED ON THE WORK**

**INSERT NAME OF TENDER**

**SCHEDULE E  
SCHEDULE OF SUB-CONTRACTORS**

**INSERT NAME OF TENDER**

## **Bid Format**

### *Irrevocable Standby Letter of Credit*

Date of issue: \_\_\_\_\_ Standby LC number: \_\_\_\_\_

Date of expiry: (approx. 3 months )

Beneficiary:

Provincial Treasurer, Government  
of Prince Edward Island

Applicant:

( Contractor )

Amount: \_\_\_\_\_  
Canadian dollars

We hereby issue in your favour this irrevocable standby letter of credit which is available by payment at sight against your written demand accompanied by the following documents :

1. The original of this credit.
2. Beneficiary's signed certificate specifying amount claimed and certifying that ( Applicant's company name) has withdrawn their bid within the period of bid validity regarding (bid details.....), or, their bid having been accepted has either:
  - a. Failed to enter into formal contract
  - or
  - b. Failed or refused to furnish the performance security as per instructions to the bidder.

Partial drawings are permitted

Except as otherwise expressly stated this credit is issued subject to uniform customs and practice for documentary credits, 1993 revision, icc publication no. 500.

We engage to honour presentations submitted within the terms and conditions indicated above.

Signed and Sealed by:



**Performance Format**

***Irrevocable Standby Letter of Credit***

Date of issue:

Standby LC Number: \_\_\_\_\_

Date of expiry: November 30<sup>th</sup>, \_\_\_\_\_

Beneficiary:

Applicant:

Provincial Treasurer, Government  
of Prince Edward Island

( Contractor )

Amount: \_\_\_\_\_  
Canadian dollars

We hereby issue in your favour this irrevocable standby letter of credit which is available by payment at sight against your written demand accompanied by the following documents:

1. The original of this credit.
2. Beneficiary's signed statement specifying amount claimed and certifying that ( the applicant) is in default of the terms and conditions of the Contract / Agreement Number ..... dated ..... covering ( *describe job / work order* ) and the amount claimed represents funds required to correct such failure.

Partial drawings are permitted

Except as otherwise expressly stated this credit is issued subject to uniform customs and practice for documentary credits, 1993 revision, ICC Publication No. 500.

We engage to honour presentations submitted within the terms and conditions indicated above.

Signed and Sealed by:

## **APPENDIX 2**

### **ENVIRONMENTAL REQUIREMENTS**

**Department of Transportation and Public Works  
Province of Prince Edward Island**

**- Environmental Management Section -**

## ENVIRONMENTAL REQUIREMENTS

---

### TABLE of CONTENTS

---

1. Description
2. Conditions of Approval
3. Compliance and Delays
4. Prevention of the Transportation / Introduction of Invasive Species
5. Pollution Control
6. Water and Runoff Control
7. Release of Fuel and Other Hazardous Substances
8. Accidental Events and Environmental Emergencies

## ENVIRONMENTAL REQUIREMENTS

### 1. DESCRIPTION

1. The Contractor shall carry out the work on the Contract according to the Plans and Specifications and in such a manner so as to be in compliance with various Acts and Regulations of the Province of Prince Edward Island and/or the Government of Canada which concerns the protection of the environment, and any approvals or permits issued to the Owner or the Contractor in accordance therewith.
2. Environmental protection measures shall be installed whenever possible prior to the commencement of the work.

If not possible to provide the environmental protection prior to the commencement of the work, the Contractor shall, as a minimum, have all materials required for the environmental protection available on site prior to the commencement of any work and shall install the environmental measures as soon as practical in the work progression.

3. If, during the work, any suspected artifacts of historical or archaeological value are uncovered or any endangered plant or animal species or any contaminated soil(s) is identified, the Contractor shall cease work until the site has been reviewed by representatives of the appropriate agencies and the Engineer has approved resumption of the work.
4. The Contractor shall follow sound environmental construction practices. Guidance in this practice to the application of his work shall be derived from, but not limited exclusively to, the following documents:
  - ▶ Division 800 of the Specifications Manual - Environment
  - ▶ Environmental Requirements, Appendix 2.
  - ▶ P.E.I. TPW's Environmental Protection Plan

### 2. CONDITIONS OF APPROVAL

1. The Contractor shall complete the work in accordance with the following conditions:
  - ▶ All sediment and erosion control measures shall be carried out as detailed on the Plans and as included in the Specifications.
  - ▶ Measures determined by the appropriate regulatory authorities (i.e. Provincial Environment Department, Fisheries and Oceans Canada, etc) as necessary for the protection of watercourses affected directly or indirectly by the Work.
  - ▶ Conditions outlined in the associated Approval-to-Proceed issued by TPW's Environmental Management Section.
2. Any debris and excavated material within the work area shall be removed from the watercourse and adjacent areas for disposal or placement in a manner such that it cannot be returned to the watercourse.
  - ▶ Removal of debris, whether natural or left behind by others, will be measured for payment in accordance with provision 103.03, Extra Work.

- ▶ Removal and disposal of excavated material will be measured for payment under the appropriate excavation item(s).
3. All necessary precautions shall be taken by the Contractor to prevent discharge or loss of any harmful material into a watercourse including, but not limited to, creosote, fuels, hydrocarbons, biocides, fertilizers, cement, lime, paint or fresh concrete.
  4. No work, including but not limited to grubbing, excavation, embankment construction or installation of drainage structures shall take place within the buffer zones on both sides of each natural watercourse, until the appropriate sediment control fence and erosion control structures are installed.
    - ▶ The installation and maintenance of these structures shall be in accordance with Sections 806, 808 and 810.
  5. In dewatering an excavation, whether a roadway cut, foundation excavation, a pit or a quarry, the Contractor shall ensure that any turbid water pumped out or released has a suspended solids level, by the time it reaches a watercourse, of no more than 25 mg/L or other level approved by the Provincial Environment Department.
    - ▶ When dewatering is conducted for roadway and foundation excavations, any erosion control measures required to achieve this level of compliance ( $\leq 25\text{mg/L}$ ) shall be constructed in accordance with and measured for payment under the appropriate Item(s) pertaining to the work.
    - ▶ It shall be the Contractor's responsibility to install and maintain, at his cost, to the satisfaction of the Provincial Environment Department, any erosion control measures for pits and quarries that may be required, and to obtain permission to pump or release any turbid water onto properties abutting and beyond.
    - ▶ The Contractor shall be responsible at his cost for any and all damage resulting from the dewatering.
  6. Slopes for soil fill materials over natural watercourses shall be stabilized immediately upon completion of culvert installation or, as a minimum, at the end of each days' embankment construction as follows:
    - ▶ Random R5 riprap or larger shall be placed to a 300 mm depth over geotechnical fabric from toe of slope to a minimum of 1 m above the top of the culvert (pipe or box). This riprap apron shall extend to a minimum of 3 m on either side of the culvert, and shall be wider at the Engineer's discretion.
    - ▶ To a minimum distance of 10 m on either side of the culvert ( pipe or box), the remaining disturbed fill slope areas (not riprapped) shall be mulched from toe of slope to top of slope. This includes the slope area above the riprap to the top of the slope. At the discretion of the Engineer, slopes with larger erosion potential shall have the mulch covered by jute mat or replaced by straw blanket.
    - ▶ All mulch and erosion control mats shall be removed from slopes prior to final grading and seeding. After slopes have been graded to the satisfaction of the Engineer, and the disturbed areas have been hydro seeded, then all areas shall be re-mulched and any erosion control mats shall be re-installed.
  7. The Contractor shall not place an earth or rock causeway in the watercourse for the

purposes of creating a temporary access structure without specific approval of the Engineer and the appropriate regulatory authority(ies), in writing.

8. All in-stream work shall be carried out between June 1 and September 30, or as otherwise directed in the permit(s). The Contractor shall notify the Engineer, in writing, at least seven days in advance of the anticipated date of commencement of in-stream work.
  - ▶ In-stream work shall be kept to a minimum by either: installing the pipe in-the-dry and diverting the flow into it upon completion; by constructing a temporary plastic-lined diversion channel in-the-dry; and/or by pumping the stream flow around the work area.
  - ▶ If it is necessary to isolate the stream from the work area, the Contractor shall construct cofferdams consisting of, as a minimum, a layer of 6-mil plastic sheet, sandwiched between an outer (stream-side) wall of sandbags and an inner wall of earth fill.
  - ▶ The Engineer, upon receiving notice from the Contractor as to when construction shall actually commence, will arrange an on-site meeting with representatives from each of the Department's Environment Section, Provincial Environment Department, Fisheries and Oceans Canada, and the Contractor, prior to commencement of the in-stream work.
  - ▶ No in-stream work shall commence until the Engineer verifies with the regulatory agencies having jurisdiction, that the work site is approved for the commencement of in-stream work.
9. Erosion control measures shall be as detailed in the Contract Documents and, if additional measures are required in addition to those indicated, the Engineer shall order and approve such work under the appropriate items.
10. Any natural materials produced and/or supplied by excavation either from pits and/or quarries shall not contain any friable, soluble or reactive minerals or other deleterious materials or conditions that would make the material prone to decomposition or disintegration, or present any environmental hazard, from the presence of the parent material or its by-products, when exposed to the natural elements after placement in the work.
11. Additional conditions of approval, as specified in environmental permit(s) issued to the Owner for the work, and/or as detailed in the Contract Documents, shall be carried out by the Contractor.

### **3. COMPLIANCE AND DELAYS**

1. For each maintenance or construction project, a project assessment/registration application must be submitted by the proponent (typically the project manager or supervisor representing PEITPW) to the Environmental Management Section for review and approval. Once the project application is received, the Environmental Management Section will coordinate all aspects of its review and assessment, issuance of associated permits and approvals from the Section or other regulatory agencies.
2. The proponent is responsible to ensure that all project-related permits and approvals are posted in a visible location at the project work area at all times.

3. Failure by the Contractor to carry out the work in accordance with the requirements of this Section will result in the Contractor being liable for any fines, levies, or penalties made under environment-related Acts or Regulations of the Province of Prince Edward Island and the Government of Canada.
4. The Engineer will be responsible for the day to day field monitoring and for ensuring that the specifications are implemented by the Contractor. TPW's Environmental Management Section shall assist to ensure that all environmental protection measures which are part of the Contract are adhered to by the Contractor.
5. The Department will have Environment Officers who will act as a liaison between the Department and other Provincial and Federal regulatory bodies responsible for environmental protection. The Environment Officer will also liaise with the Engineer and assist in ensuring that environmental compliance is being enforced.
6. The Department's Environment Officers will have the authority to make recommendations to remedy insufficient environmental protection on projects, or, if need be, to make recommendations to the Director, or in his absence, to the Environmental Coordinator to have the work suspended until the Contractor commences the work as per the specifications in the Department's General Provisions and Contract Specifications for Highway Construction as well as all regulatory permits and approvals. Any suspension of work will be coordinated with the Engineer.
7. In circumstances where the insufficient environmental protection poses no immediate threat to the environment, the Contractor shall implement the necessary remedies to the satisfaction of the Department within 48 hours from their receipt of notification of the circumstances. Failure by the Contractor to meet this requirement may result in suspension of the Contractor's work, by the Director, or in his absence, the Environmental Coordinator, as per Section 3.4.
8. In circumstances where insufficient environmental protection, ongoing work activities, or site conditions do pose an immediate threat to the environment, either the Contractor's work can be suspended immediately, or immediate action by the Contractor to remedy the situation can be ordered, whichever is appropriate, by the Director, or in his absence, the Environmental Coordinator, as per Section 3.4.
9. Any delays to the Contractor's work operation resulting from suspension of work for failure to follow the requirements of this Section will not be considered as a basis of claim for extra costs, nor for any extension of the contract completion date.

#### **4. PREVENTION OF THE TRANSPORTATION / INTRODUCTION OF INVASIVE SPECIES**

##### **1. Environmental Concerns**

Waters of Atlantic Canada are experiencing the effects of invasive aquatic plant and animal species from around the world. Once these non-native or invasive species have established themselves in a new ecosystem (absent of their natural predators) they can harm native species, possibly causing entire ecosystems to be disrupted due to habitat destruction or food chain alteration (i.e. preying on native species, transmitting disease, etc.).

The principal invasive species in the Gulf of St. Lawrence and the Canadian Atlantic coast are Tunicates (*Styela clava*), Green Crab (*Carcinus maenas*) and Green Alga's

(i.e. Oyster Thief (*Codium fragile tomentosoides*)). Up to date information on the present distribution of these species in the Northumberland Strait can be obtained by calling the Habitat Management Branch of Fisheries and Oceans Canada at (902) 863-5670. Information on the Gulf of St. Lawrence can also be found at [www.glf.dfo-mpo.gc.ca](http://www.glf.dfo-mpo.gc.ca) and for the Canadian Atlantic coasts at [www.northeastANS.org](http://www.northeastANS.org).

## 2. Pathways

Non-native and invasive species may be unintentionally introduced into a marine environment via various marine construction and improvement projects. These species have the potential to alter the native ecosystems and have negative impacts on the commercial fishing and aquaculture industries. Potential pathways for spreading these species include, but are not limited to, the following:

- ▶ Species or their water borne larva travelling in bilge and ballast water of various marine construction equipment (i.e., barges, scows, etc.).
- ▶ Marine sediments remaining in excavation equipment, barges or trucks.
- ▶ Species being attached to or carried in the bottom/hull of various boats or barges.

## 3. Environmental Protection Procedures

The following protection procedures are intended to reduce the potential risk of transporting and introducing invasive marine/terrestrial species:

- ▶ All dredging equipment including excavators/cranes, floating plant, scows, barges and work boats are to be free of all marine growth prior to mobilization to the site.
- ▶ The Contractor will make all equipment available for inspection by regulatory authorities (i.e. Provincial Environment Department, Federal Department of Environment and the Habitat Management Branch of Fisheries and Oceans Canada, or other agencies) if requested. Any growth identified is to be completely removed from the equipment in an environmentally acceptable manner and using methods approved by the regulatory authority.
- ▶ The Contractor is to coordinate removal and cleaning operations to ensure they abide by all requirements of the Provincial Environment Department, Federal Department of Environment, the Habitat Management Branch of Fisheries and Oceans Canada and any other applicable agencies.
- ▶ The Contractor shall ensure that all costs associated with the requirements of this section are included in the bid price.

## 4. The Contractor is required to:

- ▶ Be familiar with Invasive Species Management Plans, Codes of Practice, or other documents that relate to the control and spread of aquatic invasive species, and acquire any special regulatory permits or approvals associated with the use of their equipment in or near a marine environment, other than the



typical permits and approvals acquired by the Department or proponent to conduct the work.

- ▶ Produce independent documentation (eg. Divers inspection reports and video of inspection, etc. of boats, barges or scows) as to when and how they had conducted the above mentioned mitigation measures, at the request of the Department or a regulatory agency, at any time.

## **5. POLLUTION CONTROL**

1. The Contractor shall not dump, spill or dispose of any overburden, trees, brush, petroleum products, or other debris into any watercourse, or other natural water basin, or into any area which may ultimately cause pollution to water drainage or storage systems and/or ground water.
2. It shall be the Contractor's responsibility to familiarize himself with the applicable legislation and regulations and to obtain all necessary permits and approvals for his operations.

## **6. WATER AND RUNOFF CONTROL**

1. The Contractor shall perform his work in a manner so as to not obstruct the flow of surface drainage or natural watercourses.
2. The Contractor shall dispose of water resulting from the work in a manner not detrimental to public and private property, or any portion of the work completed or under construction.

## **7. RELEASE OF FUEL AND OTHER HAZARDOUS SUBSTANCES**

1. The Contractor, including any subcontractors and/or any agent(s) of the Contractor involved in any aspect of the Contract, shall be responsible for all containment and cleanup of any release of fuel and/or other hazardous materials, regardless of the cause of the release.
2. This Section shall include the work site, all lands being used by the Contractor and under the control of the Owner, and/or any Crown Land being utilized for the work under the Contract.

## **8. ACCIDENTAL EVENTS AND ENVIRONMENTAL EMERGENCIES**

1. Response Procedures for Accidental Events - Contingency plans and response procedures to be followed for unplanned environmental events are provided in the *TPW Environmental Protection Plan, Section 9.0 Contingency Plans for Unplanned Events*.
2. Key Contact List - Key organizations and/or individuals that may be contacted (a) during environmental emergency situations, or (b) to assist with routine environmental issues are provided in the *TPW Environmental Protection Plan, Section 10.0 Key Contact List*.  
In general, the person managing the work, should:
  - ▶ For an environmental emergency, directly contact Emergency Response Personnel using the names and numbers provided.
  - ▶ For routine, or non-emergency issues, contact Provincial Personnel using the names and numbers provided.

## **APPENDIX 3**

### **Temporary Workplace Traffic Control Manual 2005**

Department of Transportation and Public Works  
Province of Prince Edward Island

Appendix 3 can be found on this CD called:

Appendix\_3 TW TCMBW.pdf (Black&White),

Appendix\_3C TWTCM Colour.pdf (Color).

It was not entered into the main document in this version.

Following versions will have Appendix 3 included in the main document.

## **APPENDIX 4**

### **WEIGH SCALE PROCEDURES**

**Department of Transportation and Public Works  
Province of Prince Edward Island**

## **WEIGH SCALE PROCEDURES**

### General

Where the contract includes tender items that require measurement for payment by weighing, the Contractor, as part of the work to be carried out under these terms, shall provide, install and maintain as necessary, weigh scales meeting the requirements of the Government of Canada Weights and Measures Act and Regulations, for the purposes for which the scales are to be used. Measurement Canada of Industry Canada (MCIC) will be available to resolve any disputes between the Department and the contractor when measurement problems are an issue. Department personnel are required to inform MCIC of any suspected noncompliance or measurement problems. In addition, the weigh scales shall meet the requirements of this Appendix.

### Location

Scales shall be located at the point or origin of the material being measured unless otherwise directed by the Engineer. The scale locations to be used for the contract must be approved by the Highway Safety Personnel prior to any material being moved. When, for the above locations, in the opinion of the Engineer there is a waste or loss of material between the point of origin and the materials' intended destination on the contract, the hauling operation may be terminated by the Engineer until the contractor has, at the Contractor's own expense, provided on a site approved by the Engineer, an additional scale which is close enough to the intended destination to preclude the possibility of waste or loss.

### Platform Scales

Scales must be provided which are long enough to fully support all axles of the vehicle being weighed, meeting the requirements of the Government of Canada Weights and Measures Act & Regulations.

All new scale decks purchased after January 01, 1994 should be built of steel construction.

Scale foundations shall be adequate to support without settlement the largest gross load to be carried. Scale pits shall be properly drained. Substantial retaining walls, (not necessarily concrete), shall be built at each end of the scale platform to support the entrance and exit ramps. These retaining walls shall be of sufficient strength and so placed as to support the ramp material without binding on the ends of the platform.

The approach ramp shall be constructed on a straight and level grade at the same elevation as the scale platform, for a distance at least equal to the length of the longest truck wheel base to be used on the work. Materials utilized should be of sufficient compaction to withstand vehicle weights. Ramps shall be compacted so that no settlement occurs when loaded vehicles drive over them. The ramps shall be maintained to provide a safe passage for vehicles. Vehicles shall enter and leave the platform at a speed not exceeding 10 kilometres per hour.

The scale platform and mechanism shall at all times be maintained clean and free from encumbrances such as gravel, asphalt, snow and ice. Each scale platform shall have rubber strips at each end to prevent jamming and dust/dirt buildup under the scale. All wooden decking material must be attached to the scale platform. Scale platforms shall have a barrier or curb 200 mm square along both sides to prevent vehicles from driving off the edge of the platform.

The weight indicator mechanism shall be suitably enclosed in a scale house meeting the requirements of this Appendix.

### Scale Houses

Scale houses shall be properly ventilated and shall be clean, dry and weather tight, with a minimum floor space of 4.5 sq. m and minimum head room of 2.1 m. They shall be equipped with windows which can be opened and closed from within and from which the weigher, while seated at the scale or console, has an unobstructed view of, the vehicle to be weighed, the scale platform and the approach ramp.

Scale houses shall also have the following:

1. A free sliding window or other suitable means for passing out weight tickets;
2. Screens for doors and windows;
3. A door located remotely from the scale platform (not facing scale platform) suitable for the occupants unobstructed exit in case of fire);
4. Suitable locking devices for doors and windows;
5. Door key for the weigher;
6. Table and two chairs so that the weigher can be seated during weighing operations in front of the scale or console;
7. Heating equipment sufficient to maintain the temperature in the scale house at 20° C.
8. Adequate lighting;
9. Fuel for heating and light supplied by the Contractor.
10. Sanitary facilities available nearby for the weigher. In case of port-a-potte, the units are to be maintained at an acceptable level.
11. Dust control shall be maintained on all ramps and roads within 30 metres of the scale house.

### Testing

Scales shall be tested to the satisfaction of the Engineer:

1. after initial installation and before their use on the Contract;
2. when the scale is moved to a new location;
3. when the scale has undergone adjustments, alterations or repairs to the weighing mechanism;
4. when weighing is resumed after winter suspension.

These tests shall be performed by a scale company that is recognized by the Department as reputable. These tests must use a total of 10,000 kg of test weights certified by MCIC. The scale company must provide a written copy of the calibration report to the Department, a copy to MCIC and post a copy in the scale house.

The Engineer reserves the right to check the accuracy or test the Contractor's scales at any time. MCIC may perform unscheduled inspections of the scales and their installation during the construction season.

After a scale has been rejected and the owner has repaired it, a request will be made by the owner to the Department to contact MCIC to make an inspector available as soon as practicable. The owner of the scale must send a copy of the scale repair invoice or report to the Department. Any scale which has been rejected for measurement errors by MCIC, cannot be used until it has been inspected and certified by MCIC.

Testing of scales by the Department shall not relieve the Contractor of any responsibilities under the Canada Weights and Measures Act and Regulations proclaimed under that Act.