

Choosing the Right Seeding and Fertilizing Equipment

By: Miles E. Jorgenson
Humboldt Station

INTRODUCTION

Choosing the right seeding or fertilizing implement is difficult. Every farm has a unique cropping practice, tillage strategy, soil type, trash level, and financial position. Concern over soil erosion, high input costs and an uncertain grain market have prompted farmers to look at conservation practices, fewer operations and a more diverse selection of crops.

All this has led to new equipment designs, focused on increased trash handling abilities, less soil disturbance, and various fertilizer placement options, including banding while seeding. It has also increased the need to shop carefully, to make sure the seeding and fertilizing implements can do what's expected of them. A wide diversity of seeding implements is available to cereal and oilseed growers, for all kinds of planting conditions. The choice is limited for more specialized needs like pulse crops, direct stubble seeding, and zero-tillage. With all the available options, knowing what to look for, and how to assess an implement before buying becomes highly important.

This publication addresses many important questions commonly asked about seeding and fertilizing equipment. Subject headings make it easier to find the area of interest or concern. Additional information may be obtained from references provided, or by contacting one of three PAMI test stations.

SEED AND FERTILIZER DELIVERY SYSTEMS

The delivery system meters and distributes seed and fertilizer to each opener. Accurate delivery is important for uniform crop establishment, proper plant spacing and efficient use of seed and fertilizer. The wrong metering rate or uneven distribution across the machine width wastes product and may affect yield.

Modern advances in delivery system design have made seeders easier to operate and more suitable for a wide variety of seeds and fertilizers. However, it is wise to check the machine carefully to be sure it can handle the seeds and fertilizer required, and can apply them accurately.

SEED METERING

The seed meter controls the material application rate. Each seed opener may be fed from an individual meter or one larger meter may feed several openers, such as on an air seeder. A ground drive keeps the rate constant as travel speed varies.

There are two basic types of meters: varied displacement and varied speed (FIGURES 1 and 2). Both types may be found on conventional seeders and air seeders.

With varied displacement meters, the application rate is set by changing the amount of exposed flute or by adjusting a slide gate or meter cover. With varied speed meters, rates are set by changing the speed of the meter. Some meters use a combination of varied displacement and varied speed to obtain a greater range of settings.

A greater number of meter settings will give finer control, and make it easier to precisely set the desired rate. Fine seeds, such as rapeseed which require very low application rates often require an optional slow speed drive or fine tooth metering wheel. Grass seeding attachments also allow finer control of low application rate products. Some meters offer interchangeable metering

wheels or partial covers for a wider range of seed types. This is important for handling specialty seeds such as lentils, peas, and beans. Tests have shown that many conventional cereal seed meters may seed inaccurately or crack the seeds¹. Running a small sample of seeds through the meter will indicate if it will properly meter that seed.

Metering rate errors may occur due to field slopes, varying ground speed, wheel slippage, rough terrain, too much or too little material in the hopper, or bridging over the metering cup. PAMI tests have shown that most commonly used seed meters are not affected by these things. Specific problems with certain makes of metering systems are outlined in the PAMI reports. On air seeders, metering rates can be affected by the method used to feed product into the airstream. Because the airstream is under pressure, air can blow back through the meter, reducing seeding rates. Therefore, airstream loading must be controlled, using a pressurized tank, venturi, or air lock valve (FIGURE 3).

A pressurized tank provides equal pressure on both sides of the meter to counteract hose pressure. An air line from the fan outlet pipe is fed into the tank. The tank must be well sealed as even a very small leak may cause metering errors. The advantage of the pressurized tank is its simplicity, requiring no moving parts. The sealed tank also provides good protection against wet weather.

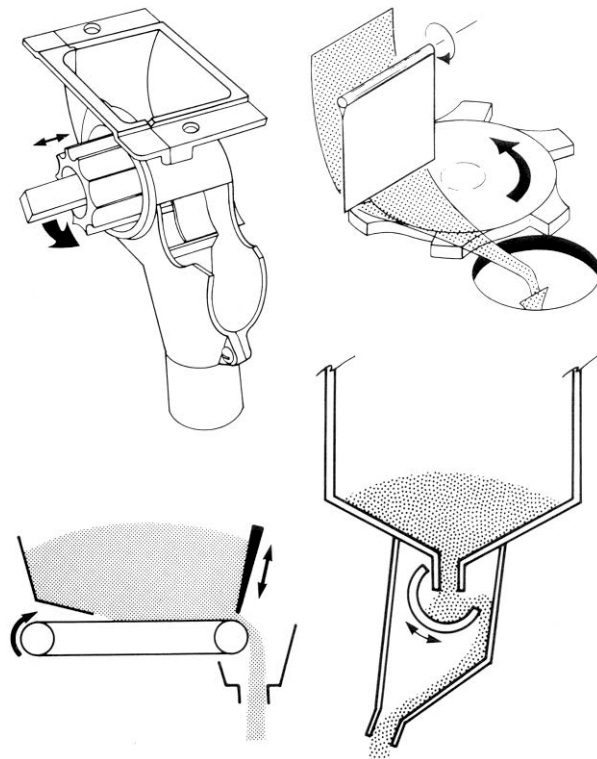

FIGURE 1. Variable Displacement Metering Mechanisms.

¹Rowland, G. G. and Kehrig, R. M. "Evaluation of Seed Metering Devices for Sowing Grain Legumes", Crop Development Center, University of Saskatchewan, 1984.

A venturi creates an air jet, lowering the pressure and allowing material to drop freely into the airstream. Venturis are simple and trouble free. The tank does not have to be well sealed, so large filler openings are possible. The main disadvantage is that maximum fertilizer application rates may be limited by the reduced inlet area needed for a proper air jet.

The air lock valve operates like a revolving door, sealing the pressurized airstream from the meter. It rotates to drop the product into the airstream. However, some air lock valves are undersized, limiting fertilizer banding rates. Also, additional moving parts and seals increase the cleaning and maintenance costs.

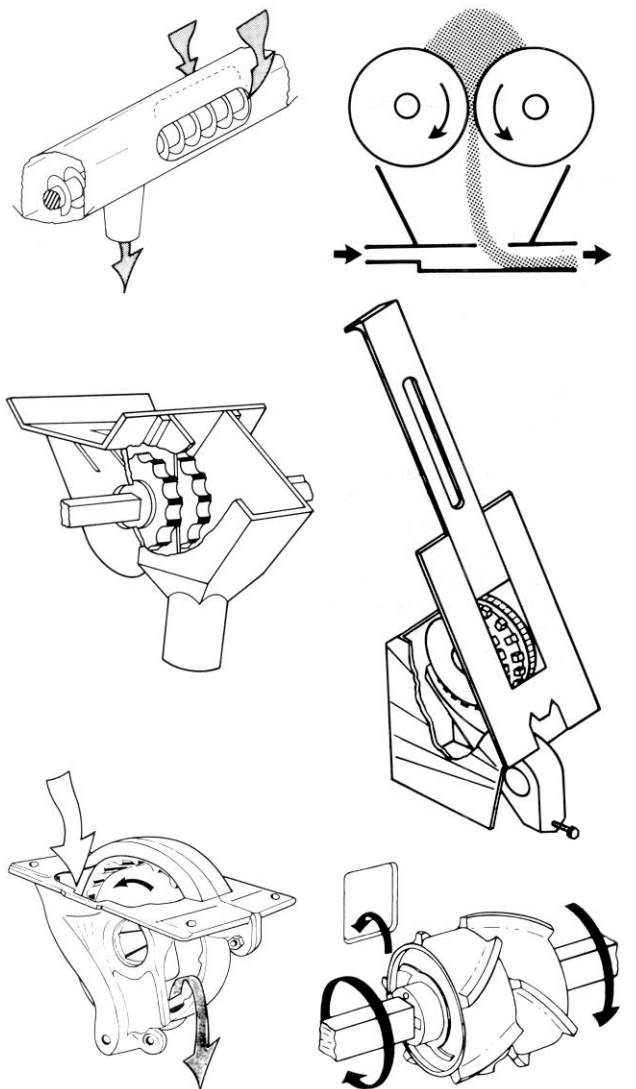

FIGURE 2. Variable Speed Metering Mechanisms.

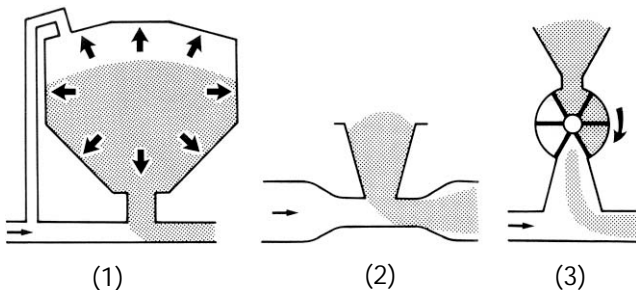

FIGURE 3. Airstream Loading on Air Seeders: (1) Pressurized Tank, (2) Venturi, (3) Air Lock Valve.

FERTILIZER METERING

Fertilizer is usually metered from a second box or separate partition. Similar metering mechanisms are used as for seed (FIGURES 1 and 2). Selection of application rates depends on the type of fertilizer, and desired placement. When fertilizer is placed with the seed, maximum required rates are usually less than 100 lb/ac (110 kg/ha)². Banding type drills or air seeders may require rates as high as 300 lb/ac (336 kg/ha). The manufacturer's chart will indicate approximately the highest rate possible for the implement.

Fertilizer meters are generally less accurate than seed meters, since they are designed more for trouble free operation than for accuracy. They are designed to resist corrosion and to meter a relatively consistent product size. A problem with some fertilizer metering systems is poor performance on field slopes. For example, FIGURE 4 shows how one meter varies on uphill and downhill slopes. When travelling down a slope greater than about 12 degrees, the meter completely shuts off!

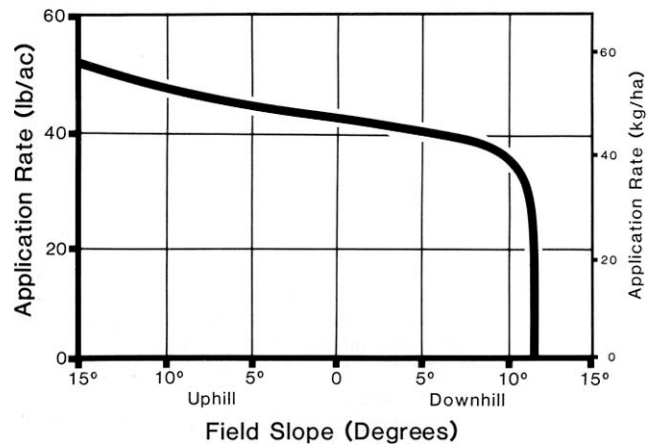

FIGURE 4. Variation in Fertilizer Application Rate with Change in Fore-and-Aft Slope While Applying 11-51-0 Fertilizer.

CALIBRATING

The actual application rate at a given setting will vary with factors such as size, type and density of the seed, making it difficult for the manufacturer to provide charts which are truly accurate for all types of seeds. A small error in the calibration should not significantly affect yield. However, large errors in calibration have been found with some supplied charts. PAMI recommends that a farmer should check the application rate himself each time a new seed type is used.

When calibrating an air seeder, it is important to run the fan and to allow air to escape from the collection containers. PAMI tests have shown that fan speed does not affect metering accuracy. However, metering may be affected by a leak in the pressurized tank, a partially restricted seed boot or manifold, and by a poorly sealed air lock valve. The equipment should be carefully inspected before calibrating.

To calibrate, the meter should be adjusted according to the supplied chart and then checked in the field. This is done in a number of different ways. One method of calibrating is to fill the boxes or tank from the truck and estimate the application rate from the area covered by one filling. An accurate area counter is needed. If you know the exact capacity of the seed or fertilizer boxes or can weigh the seed taken from the truck, this method can be reasonably accurate. However, it is not particularly convenient since a large area must be seeded while checking.

A preferred method is individual meter sampling. This is done as follows:

1. Place containers under four or more delivery hoses. With air seeders, a cloth sack or a pail with a screened lid must be used to allow air to escape.

²Anon., "General Recommendations for Fertilization in Saskatchewan", Agdex 541, Saskatchewan Agriculture, Regina, Saskatchewan, 1987.

- Calculate the number of meter rotations made over a selected distance, say 150 ft (45 m). Rotate the meter the selected number of turns while collecting the samples.
- Weigh samples and calculate the total weight. An accurate lab or grocery scale should be used.
- The application rate is calculated as follows:

$$\text{Imperial Rate (lb/ac)} = \frac{\text{Total Weight Collected (lb)} \times 43,560}{\text{No. of Outlets Collected} \times \text{Row Spacing (ft)} \times \text{Distance (ft)}}$$

or,

$$\text{SI Rate (kg/ha)} = \frac{\text{Total Weight Collected (kg)} \times 10,000}{\text{No. of Outlets Collected} \times \text{Row Spacing (m)} \times \text{Distance (m)}}$$

EXAMPLE: An air seeder is to be calibrated to apply 11-51-0 fertilizer at 50 lb/ac (56 kg/ha). Row spacing is 12 in (0.3 m). The meter drive wheel is found to turn 21 rotations in 150 ft (45 m). Containers are placed under 10 outlets. The meter drive wheel is raised off the ground and turned 21 times by hand.

Total weight collected from the 10 outlets is 1.95 lb (0.88 kg). The actual application rate then is:

$$\text{Imperial Rate (lb/ac)} = \frac{1.95 \text{ lb} \times 43,560}{10 \text{ Outlets} \times 1 \text{ ft} \times 150 \text{ ft}} = 56.6 \text{ lb/ac}$$

$$\text{SI Rate (kg/ha)} = \frac{0.88 \text{ kg} \times 10,000}{10 \text{ Outlets} \times 0.3 \text{ m} \times 45 \text{ m}} = 64.5 \text{ kg/ha}$$

This is slightly higher than the desired rate. The meter setting would be reduced, and calibration repeated until a setting was found which gave the desired rate. It is a good idea to note errors on the manufacturer's chart for future reference.

Devices are now available to make calibrating much easier (FIGURE 5). The calibrated tube gauge is very easy to use and comes with instructions. However, because the scale reads only in bushels per acre, it is not suitable for fine seeds and fertilizers, where rates are expressed in lb/ac (kg/ha). Weighing balance scales are also easy to use, and provide accurate calibration with any product at nearly any application rate. They usually read directly in lb/ac (kg/ha), and include calibrating instructions. Some of these scales may also be used to determine product densities. Several equipment manufacturers are now providing calibrating tools with their seeders. Considering the importance of correct application rate, and the ease of using these calibration tools, they are definitely worth the small cost.

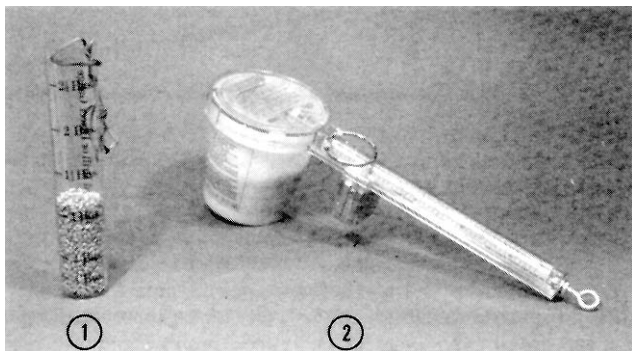

FIGURE 5. Calibration Tools: (1) Calibrated Tube Gauge, (2) Weighing Balance Scale.

DISTRIBUTION UNIFORMITY

Distribution uniformity indicates variation in delivery between openers. The coefficient of variation (CV) is a mathematical term used to describe distribution uniformity.

$$\text{Coefficient of Variation (CV)} = \frac{\text{Standard Deviation (SD)}^2 \text{ of Sample Weights (g)} \times 100}{\text{Average Sample Weight (g)}}$$

PAMI has accepted the following scale as its basis for rating distribution uniformity of seeding implements:

- CV greater than 15% -- unacceptable
- CV between 10 and 15% -- acceptable
- CV less than 10% -- very good
- CV less than 5% -- excellent

³Standard Deviation, $SD = \sqrt{\frac{(w_i - \bar{w})^2}{n - 1}}$; where w_i = weight of sample i , \bar{w} = average weight, n = number of samples

For example, FIGURE 6 shows unacceptable distribution uniformity across the width of an air seeder.

A simpler but less accurate method can be used to get a reasonably reliable indication of uniformity. Collect a sample from each outlet and determine the average weight. Outlets within 15% of the average weight are acceptably uniform. If several outlets differ from the average by 15% or more, distribution is not uniform. PAMI reports on each machine indicate the cause of uneven distribution, and may suggest improvements.

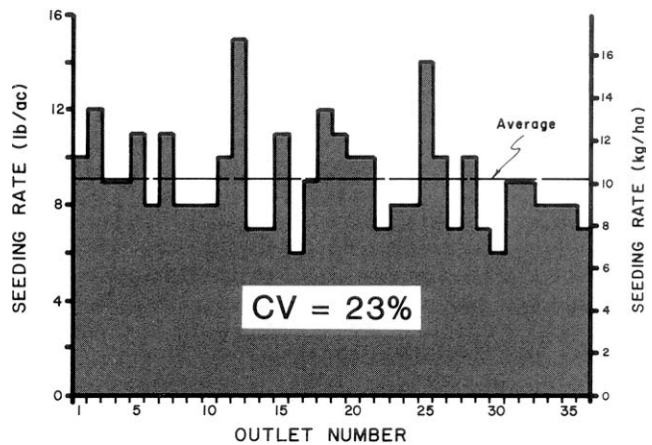

FIGURE 5. Example of Distribution Uniformity Pattern.

GRAVITY DELIVERY SYSTEMS

Distribution is usually uniform with individually metered gravity systems. Some varied displacement meters have CV's greater than 15% when applying oilseeds. Using an extra slow speed drive kit and tightening any free play in the flutes will usually improve distribution of fine seeds.

AIR DELIVERY SYSTEMS

On air seeders, airflow is used to distribute the seed and fertilizer from a single meter or a few meters through manifolds.

There are three main types of air distribution systems (FIGURE 7). Type A systems use a single meter feeding into one airstream. The product is delivered through a primary and several secondary manifolds. Type B systems use more than one meter and have no primary manifold. Product flow is split through secondary manifolds only. On Type C systems, an individual metering cup is provided at the tank for each opener, and air is used only to move the product, not to split it.

Since Type C systems have no manifolds, distribution is as uniform as with conventional seeders. Generally, distribution has been more even with Type B systems than with Type A systems. Not all Type A systems produce uneven distribution, but PAMI's tests of air seeders have shown that while some were very good, others were "unacceptable."

Tests have indicated that uneven distribution may be caused by sharp bends in the hoses just before a manifold, large differences between hose lengths, unmatched hose sizes, non-symmetrical manifold design, operation on side slopes, very low fan speeds and blocked manifold outlets. Manifold outlets are often deliberately blocked off to match the number of shanks on different sizes of cultivators. Manufacturers have been urged to supply manifold sizes to match most cultivators so that outlets will not have to be blocked off.

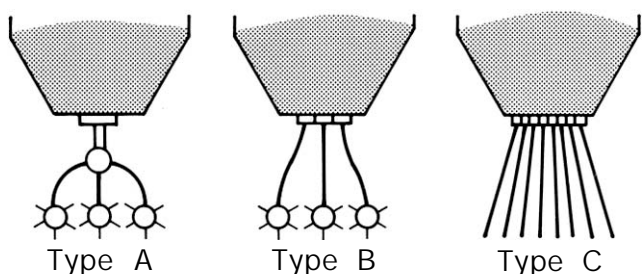

FIGURE 7. Air Seeder Distribution Systems.

Other design features which have been shown to improve distribution uniformity include corrugated tubing sections, deflectors in pipe bends, sections of straight pipe between the bend and the manifolds, and convex shaped manifold caps. Specific information is available in the evaluation reports on air seeders.

Some air seeder manifolds cause excessive grain damage particularly with rapeseed. For example, as much as 30% seed damage occurred in some tests when fans were operated at high speeds. Most manufacturers suggest using reduced air velocity when seeding rapeseed.

FILLING AND CLEANING

One great advantage of air seeders over gravity boxes is their ease of filling and cleaning. The single central tank can be filled without moving the truck or filling auger. Many farmers have reported a time saving with air seeders since less time is spent filling the tanks. A self-contained loading auger simplifies filling, since drill fills may not reach the high tank openings. For both air seeders and drills, tank or box lids higher than about 7 ft (2.1 m) are difficult to reach with a drill fill.

The seed and fertilizer compartments should be matched so they require filling at about the same time. Obviously, this will vary depending on application rates. For example, when applying 60 lb/ac (67 kg/ha) wheat with 50 lb/ac (56 kg/ha) of 11-51-0 fertilizer, the correct ratio of seed volume to fertilizer volume is about 1.5 to 1.0. Grasses and other fine seeds are often stored in a separate smaller box because the amount required is so small. When applying canola and fertilizer together, the ratio may be as low as 0.2 to 1.0. Many air seeders permit both seed and fertilizer hoppers to be used for fertilizer or seed storage. This greatly increases the capacity when only seed or fertilizer is being applied.

Air seeders and drills have various systems for cleanout. Boxes or tanks with swing-open bottoms are very convenient. Some have removable metering cups to facilitate cleaning and changing the metering wheels.

Moisture buildup may be removed from air seeder hoses by running the fan a few minutes before starting seeding or fertilizing. In damp weather, the fan should be left running to remove all product from the hoses before shutting down.

SEED PLACEMENT

Seeds should be placed into moist, firm soil at a uniform depth. Good contact between seed and soil ensures rapid, even germination. Straw and chaff must be cleared away from the seed furrow as it may reduce the contact between seed and soil. Poor depth control produces widely varied emergence, often resulting in uneven maturing stands. It is the function of the seed opener to create the best possible seedbed.

Several types of openers are commonly used on the prairies (FIGURE 8). A disk seeder turns the soil completely over which helps to bury trash and kill weeds. Disk drills cut a narrow slot

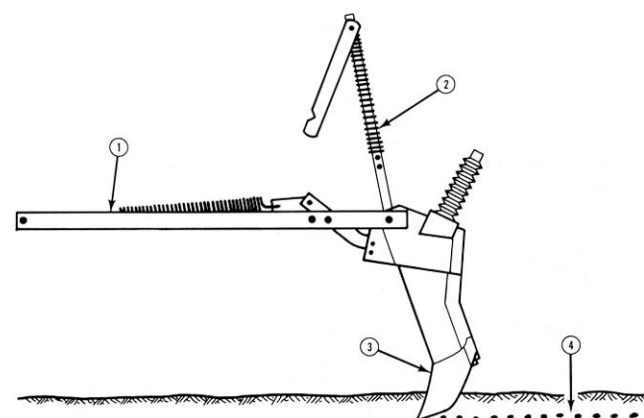

FIGURE 8 . Seed Placement Opener: (1) Frame, (2) Pressure and Depth Adjustment, (3) Soil Tool, (4) Seed and Fertilizer.

with very little soil disturbance. Hoe drills and air seeders plow through the soil with a moderate amount of tillage, depending on the type of shank or sweep.

Selecting the best opener depends on what crops are grown, what tillage strategy is used, and on the type of soil and amount of crop residue. Most farms grow a variety of crops on both summer-fallow and stubble. Some seeding flexibility is therefore useful. No opener is able to handle all conditions exactly as desired, but the following guidelines should help in selecting the most suitable one.

DEPTH CONTROL

Generally, cereal seeds should be planted 1.5 to 2.0 in (40 to 50 mm) deep. Fine seeds like rapeseed, flax or grasses should be placed only deep enough to ensure adequate moisture and seed cover, usually 0.5 to 1.0 in (10 to 25 mm). Large seeds like peas, beans and corn may be planted up to 4 in (100 mm) deep if the soil is dry⁴.

It is also important that seeding depth be uniform. If the seed depth varies within a field, the crop will emerge unevenly, and maturity will vary. Research has indicated that yields may be affected as well⁵.

Uneven seeding depths may be caused by poor ground following of the openers, or by scatter from the seed spout or seed boot (FIGURE 9). If the furrow bottoms are uniform in depth across the machine and along the seed rows, then the openers are following the ground evenly. If most seeds are placed within 1/2 in. (12 mm) of the furrow bottom, then seed scatter is acceptable.

Seed depth may be checked by uncovering the seeds behind the seed openers. As a rule of thumb, depth is measured from the unworked field surface to the seeds placed behind the opener (FIGURE 10).

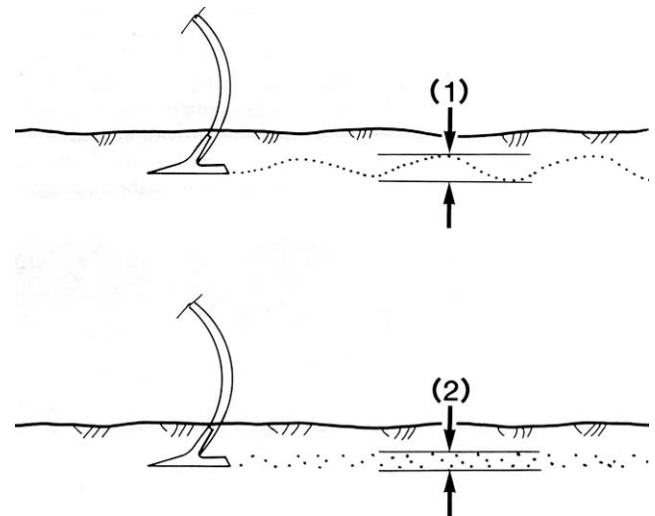

FIGURE 9. Causes of Poor Depth Control: (1) Uneven Ground Following, (2) Scatter.

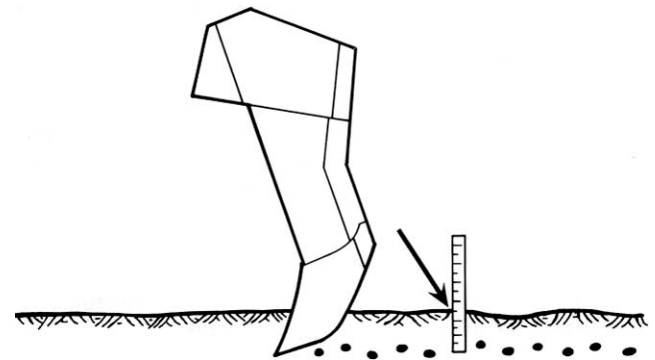

FIGURE 10. Checking Seed Depth Behind the Opener.

⁴Anon., "Guide to Farm Practice in Saskatchewan", University of Saskatchewan, Saskatoon, Sask., 1987, pp. 102.

⁵Anderson, C. H. "Effect of Seeding Depth on Three Varieties of Spring Wheat", Agriculture Canada, Swift Current, 1974.

Uneven Ground Following: Uneven ground following is most often caused by improper frame levelling, a large inflexible frame, uneven opener penetration or by wheel sinkage.

First, the hitch and frame should be levelled, and the openers must be set across the full width. Adjusting procedures are usually listed in the operator's manual. Depth should be checked periodically to ensure the frame stays level, and all openers work at the same depth.

Conventional double disk drills do an excellent job of shallow seeding in preworked land. However, they are not intended for seeding into firm, untilled fields. The disks cannot penetrate hard ground. Zero-till drills which use disk openers are much heavier than conventional double disk drills. A third coulter ahead of the double disks is often used to improve drill penetration and depth uniformity under minimum and zero till conditions.

Diskers penetrate well in firm soils. Small disks with deep concavity penetrate more easily than larger disks. Gauge wheels attached to the gangs greatly improve depth control where the soil conditions are variable.

Poor penetration may also occur with an air seeder or hoe drill if the shank trip or cushion spring releases too easily. Many light duty cultivators and hoe drills are not suited for stubble seeding in heavy soils. A heavy duty or intermediate duty cultivator should be used for stubble seeding. PAMI reports indicate the suitability of particular hoe drills and air seeders for stubble seeding.

Compared to a hoe drill, the depth of a cultivator can vary greatly on rolling land (FIGURE 11). The wide cultivator frame and long hitch do not allow the shanks to follow ground contours.

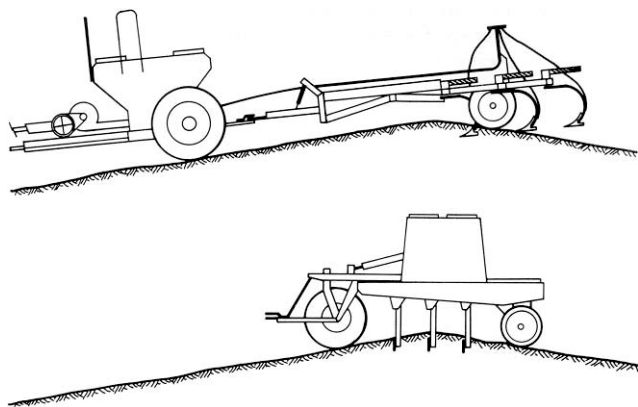

FIGURE 11. Ground Following Ability of Cultivator and Hoe Drill.

To improve depth control, the cultivator must more closely match the hoe drill frame geometry. Air drills have been introduced which use basically a hoe drill frame with an air delivery system. But an air drill cannot be used for conventional tillage. Improvements to the conventional cultivator may be more practical, as the cultivator is a multiple-use implement.

Narrower frame sections, floating hitches, flexible wing couplings, additional wheels and rear mounted packer gangs have all helped improve depth control. A relatively new design has the seed opener attached to a gauge wheel and these units trail the shanks (FIGURE 12). The gauge wheels ensure accurate seed placement even if the shank depth varies.

Electronic depth controllers are available and can improve depth uniformity of cultivators where wheel sinkage is a problem. Tests by PAMI have concluded that electronic depth controllers are useful in fields with alternating hard and soft areas. However,

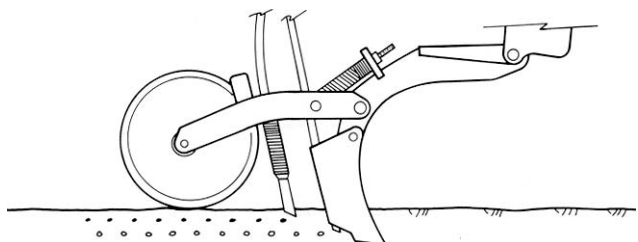

FIGURE 12. Shank Mounted Gauge Wheel Seed Opener.

they do not improve seed depth uniformity on rolling land where the rigid frame does not follow ground contours. Hitch tilting controllers are being developed to help overcome this problem.

Seed Scatter: Seed scatter occurs when the seed is poorly placed into the furrow or when it bounces after hitting the furrow bottom. It is often caused by travelling too fast, seeding into lumpy or trashy soil, or by poor seed spout or boot design.

Disk drills and hoe drills normally have little or no seed scatter.

On diskers, the seed spout should be aimed directly at the furrow bottom just behind each disk. Spouts should be checked frequently for damage or poor alignment.

On air seeders, scatter is more likely to occur with boots that project the seeds rearward rather than forward (FIGURE 13). Forward projecting boots trap the seed under the wings of the sweep, preventing bounce and reducing scatter. PAMI tests have shown that the air blast on an air seeder does not affect seed scatter.

ROW SPACING

The question of optimum row spacing has not been fully answered. Some preliminary Agriculture Canada research results have indicated higher yields for row spacings as narrow as 3 in (75 mm) in both canola and wheat. In different conditions, other preliminary research results indicated a 12 to 15 in (300 to 380 mm) row spacing yielded slightly higher than narrow rows. The effect of the row spread width on yield is also not clearly understood.

Air seeders provide some flexibility in row spacing and spread width. Shank spacings may be adjusted with some makes, from 8 in (200 mm) up to 12 in (300 mm). The seed may be placed in tight bands behind banding knives or chisels, or it may be spread behind a sweep. When shank spacing is 10 in (250 mm) or wider, spreader boots are recommended to make sure there is adequate stubble support for a windrow. The widest spread is obtained from a forward full spreading seed boot. Seed drills are available with a variety of row spacings, but few offer adjustable row spacing.

Four basics should be considered when comparing row spacings: (1) narrower row spacing requires extra seed openers, and hence extra cost, (2) narrower spacing reduces trash clearance and, on disc drills, increases the weight required for good penetration, (3) wide row spacing may not provide enough stubble support for windrows at harvest time, (4) wide row spacing disturbs less stubble, which helps trap snow cover when planting winter wheat.

TRASH MANAGEMENT

Trash or surface crop residue becomes a problem for seeding equipment, particularly if it's not chopped or spread. Large quantities of crop residue interfere with proper seed placement by reducing seed contact with the soil.

Proper trash management should begin at harvest. Straw and chaff may be chopped and spread on the combine, or removed from the field by baling. Bunches and piles of straw may be broken and spread by high speed harrowing in the fall or early spring when the straw is dry and brittle.

Trash Cutting: A disk implement must try to cut through the crop residue layer to get the seed into the soil. If trash is not cleanly cut, the seed ends up poorly placed and mixed with the trashy soil at uneven depths. This is usually the case with disk drills. They push the trash down into the seed slot (FIGURE 14), placing the seeds over the straw or chaff where they cannot properly germinate.

Trash cutting ability is improved with a leading coulter disk, increased disk pressure and some modified disk configurations. For example, an Agriculture Canada experimental zero-till drill used disks of unequal sizes, and mounted one disk slightly ahead of the other. Where crop residues are particularly heavy, a disk drill should not be used.

Diskers generally have acceptable trash cutting ability. In heavy trash conditions, smaller diameter disks and a narrower width of cut improve trash cutting.

Hoe drills and air seeders slide underneath the surface residue, so are not affected by trash cutting.

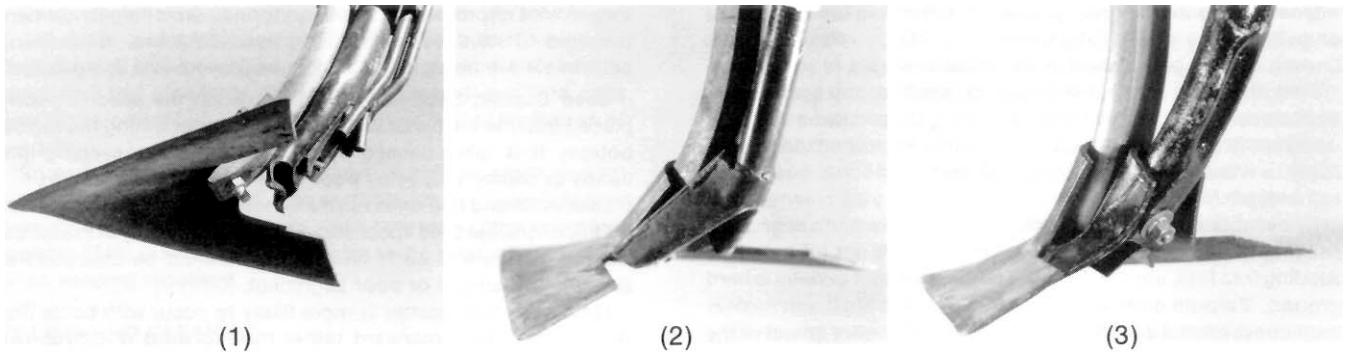

FIGURE 13. Air Seeder Boots: (1) Rearward Deflecting, (2) Forward Y-Dividing, (3) Forward Full Spreading.

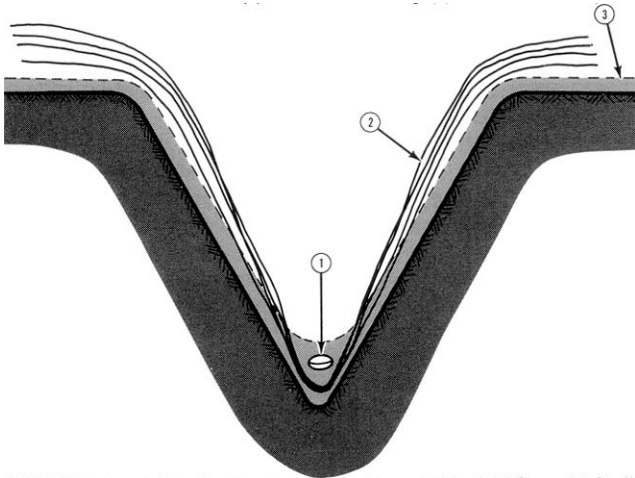

FIGURE 14. Double Disk Seeding into C Residues: (1) Seed, (2) Straw, (3) Chaff.

Trash Clearance: Hoe drills may easily plug with trash. This is often a result of insufficient ground clearance under the frame (FIGURE 15). PAMI found that at least 20 in (500 mm) of ground to frame height is required for good trash clearance. Clearance between the ranks of hoes is also important. A three-rank hoe drill has better clearance than a two-rank. Tests have also shown that curved shanks will lift and separate the straw better than straight vertical shanks.



FIGURE 15. Trash Plugging in a Hoe Drill.

Trash clearance with diskers and disk drills is improved with larger diameter disks, however, this reduces trash cutting ability. PAMI tests have shown that with good trash management, the disk diameter will not greatly affect seed placement.

Air seeders usually have excellent trash clearance. Cultivators are well suited to unworked stubble because they have wide shank and rank spacing and high clearance frames.

Trash Burial: All seeding implements disturb some soil and bury some trash. High trash burial may be desired for some seeding operations like weed control or chemical incorporation. For other operations such as winter wheat seeding or zero-till, trash burial must be minimal.

TABLE 1 shows typical trash burial for common seeding implements.

TABLE 1. Trash Burial.⁶

IMPLEMENT TYPE	TRASH BURIAL IN EACH PASS (%)
Disk Drill	5 - 10
Hoe Drill	10 - 15
Zero-Till Drill	5 - 15
Disk Drill	50
Air Seeder	20 - 30

FERTILIZER PLACEMENT

TYPICAL RECOMMENDATIONS^{7&8}

The two most commonly applied fertilizers in Western Canada are phosphate (P205) and nitrogen (N).

Phosphate (P205) is required during all stages of growth, especially during germination and emergence. It does not leach and is not harmful if placed near the seed. Recommendations vary, but generally researchers suggest that phosphate should be applied with the seed.

Nitrogen (N), on the other hand, can be harmful to the seed if large quantities are placed in the seed row. Nitrogen is easily lost to the atmosphere, and moves readily with soil water. For these reasons, nitrogen should be placed in the root zone away from the seedlings. The optimum distance between seed and fertilizer has not been clearly proven.

The choice of fertilizer applicator must be based on trying to achieve the desired placement. However, timeliness, capital cost, availability, ease of operation, and performance should also be considered. There are many choices (FIGURE 16), each with its advantages and disadvantages. The following discussion should help assess the most appropriate method for a given situation.

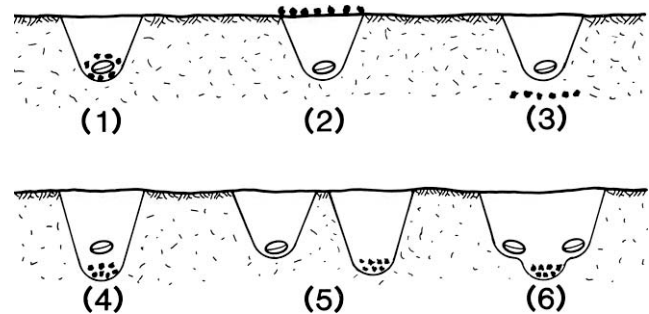

FIGURE 16. Fertilizer Placement: (1) Seed Placed, (2) Broadcast, (3) Pre-Seed Banded, (4) Below-Seed Banded, (5) Side Banded, (6) Paired Row Banded.

SEED PLACED

When only phosphate is applied, seed placed is the cheapest and most effective method of application. Nitrogen fertilizer in the seed row may cause seedling damage if rates exceed about 25 to 40 lb/ac (28 to 45 kg/ha) of actual N. Slightly higher rates may be seed placed if the seed is spread, such as with an air seeder boot. However, high rates of nitrogen fertilizer generally should not be seed placed.

⁶Woodruff, N. P., "Stubble Mulch Tillage and Planting in Crop Residue in the Great Plains", Transactions of the ASAE, St. Joseph, Michigan, 1966.

⁷Harapiak, J. P., "Fertilizer Forum", Country Guide Magazine, 1986.

⁸Anon., "Saskatchewan Fertilizer Practices", 1986, Saskatchewan Agriculture Soils and Crops Branch.

Nearly all seeders sold on the prairies are equipped with a fertilizer box and metering mechanism. The fertilizer is simply dropped down the seed tubes along with the seed, so cost of application makes this method attractive.

BROADCAST

Broadcast application is useful for top-dressing nitrogen onto a growing crop such as winter wheat or when the soil is too wet to be worked. Broadcast application is also recommended where tillage is not possible, such as in hay or pasture land. The costs of application is low, but it is commonly accepted that broadcast application is less efficient than banding because nitrogen loss is high and fertilizer is not placed in the root zone. Also, spread patterns are often uneven, and metering rates are difficult to check.

SPRING OR FALL BANDED

Banding at depths of 3 to 5 in (75 to 125 mm) will place the fertilizer in the root zone. Banding in the fall or spring prior to seeding has several potential advantages. Fertilizer costs may be lower in the fall, so time and manpower is saved at seeding time since fertilizer need not be handled, and the same implement may be used for both fertilizing and seeding. There are some disadvantages to this method, such as additional fuel costs, higher power requirements at the greater depths, moisture loss and erosion due to extra tillage, and possible loss of fertilizer due to overwinter leaching.

Knives used for banding this fertilizer have been evaluated by PAMI and compared to a standard 2 in (50 mm) chisel point. The knives placed the fertilizer in more concentrated bands which may reduce losses, especially in fall. Soil disturbance was also less with knives. However, knives were harder pulling than chisels, requiring about 20% more power at the same depth and speed. Knives also penetrated poorly once the hardened tips had worn back. Knives are more expensive than chisels, but replaceable tips and a harder wearing surface prolongs their life.

BELOW-SEED PLACED

Theoretically, openers that place the fertilizer directly below the seed should improve nitrogen fertilizer efficiency. However, good seed-fertilizer separation is difficult to maintain with this type of opener. Soil must flow quickly around the opener to reach the furrow bottom and cover the fertilizer before the seed is dropped on top. This also places the seed in a loose seedbed and reduces soil contact, which can result in poor germination. Packing usually pushes the seed down closer to the fertilizer, thus reducing the original separation.

SIDE-PLACED

Side placement of fertilizer has been favored in some research, which showed that fertilizer should be located about twice the seeding depth, and off to one side. The seedbed is not disturbed, seed-fertilizer separation is excellent, and fertilizer depth may be independently controlled.

Side-banding equipment is expensive. Since separate openers are used, the drill has twice as many disks or hoes as a conventional drill. The extra openers reduce trash clearance, disturb more soil, increase repair costs and greatly increase power requirements.

PAIRED ROW PLACED

Paired row banding has the advantages of side-banding, plus a reduced number of openers. Only one row of fertilizer is used for each two rows of seed. The optimum spacing for nitrogen fertilizer bands is 8 to 16 in (200 to 400 mm), while seed rows are typically spaced at 8 in (200 mm) or less. By sharing one fertilizer row, fewer openers are required, less soil is disturbed and power requirements are less than for side-banding. Fertilizer placement in paired rows seems favorable although more research is required to determine any yield advantage.

Several manufacturers are now developing equipment for paired row banding. Hoe drills, disk drills, and air seeders are

available with paired row openers. Some manufacturers have combined the seed and fertilizer boots into a single opener, reducing cost and complexity. Many new machines have been introduced, but the farmer should be cautious when buying unproven equipment. Not all "paired row" implements form effective paired rows, and soil disturbance may be high. It is advisable to see a machine in operation before buying.

OTHER METHODS

Precise fertilizer placement has been attempted by several different means. A spoked wheel injector has been developed for point-injecting liquid fertilizer. Liquid fertilizer has also been blasted into the soil using a high-pressure nozzle. Other researchers have tried dropping granular fertilizer in clumps or nests along each row, or banding large fertilizer capsules. Results have been good, but equipment is not widely available and in many cases it may be quite complex and expensive.

PACKING

Packing enhances soil to seed contact, reduces moisture loss and therefore ensures more uniform and rapid germination.

TYPES OF PACKERS

A wide range of shapes and materials are used for packer wheels (FIGURE 17). In Western Canada, the most common is the "V" shaped steel packer. The steel "V" packs directly over the seed row with fairly high pressure, and leaves a ridged surface. Concentrated packing usually produces rapid, even emergence, since seeds have good soil contact. They reach the surface sooner, too, because of the ridges.

Rubber packers are useful in wet sticky soils, heavy clays and stony land because they flex to reduce soil buildup and soften the impact of stones on the drill. Rubber may also be used where a smoother surface finish is desired for crops such as oil seeds.

Modern plastic materials are being used for packer wheels which are lighter than steel. Plastic has good impact resistance and should reduce mud sticking, but like all new technologies, more field experience is required to determine their long term durability. Additional weight for plastic packers is usually transferred from the cultivator frame.

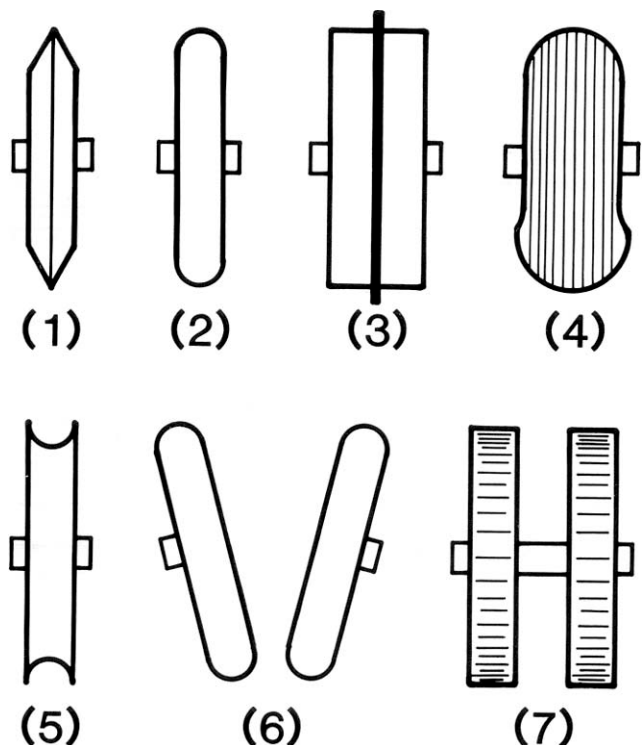

FIGURE 17. Packer Wheels: (1) "V", (2) Convex, (3) Center-Ribbed, (4) Tire, (5) Concave, (6) Furrow-Closing, (7) Solid Rubber.

AMOUNT OF PACKING

Conventional drill packing weight ranges from about 130 to 300 lb (58 to 136 kg) per packer wheel. Some zero-till drills provide over 400 lb (180 kg) per packer wheel. The amount of packing required is dependant on soil conditions. Dry soils must be well packed while wet soils and soils with low organic matter should be packed less. Unworked fields, such as zero-till fields, require more concentrated seed row packing. A wide packer reduces the soil pressure over the seed row, but packs more of the seeds when seeds have been spread, as with an air seeder.

Packing behind air seeders and diskers is required since they leave the soil very loose. Coil packers are usually adequate, though a second packing operation may be required in sandy or dry soils. Rear mounted packers are available for air seeders to improve ease of transporting and to provide concentrated packing over each seed row. Shank mounted packer wheels provide adequate packing, but may interfere with shank trip height, and may reduce trash clearance.

Harrowing or rod weeding after seeding helps to level the surface, control weeds, and may provide some packing. This operation does not normally provide enough packing to take the place of packer wheels, except in heavy clays or wet conditions.

POWER

The power required to pull a seeding implement is influenced by many factors. The type of opener used, depth and speed of travel, implement width, rolling resistance from the tires, and opener penetrating force or packer wheel weight all affect the size of tractor needed. Power is also required to operate the PTO, hydraulic or ground driven fan on air seeders.

It is difficult to specify the exact power requirement for a given implement on a given farm because so many variables are involved. The PAMI reports provide an expected power requirement based on field measurements in average soil conditions. The tractor size listed in a PAMI report is adjusted to account for tractive efficiency due to slippage and transmission loss, and to provide for a tractor operating at 80% of maximum rated power-take-off output. Air seeder fan power is included in the tractor size recommendation.

The table below lists average power requirements for 32 different seeding implements tested over 12 years in the three prairie provinces. Individual machine power requirements varied from the average by as much as 60%, especially for hoe drills. Separate PAMI reports should be consulted when attempting to match a tractor to the implement.

TABLE 2. Typical Power Requirements for Seeding Implements Operated at Seeding Depth 2 to 2.5 in (50 to 63 mm) and Speed of 5 mph (8 km/h).

IMPLEMENT	SEEDING CONDITIONS	TRACTOR PTO POWER	
		hp/ft	(kW/m)
Disk Drill	Summerfallow	2.5	(6)
	Zero-Tillage	9.0	(22)
Hoe Drill	Summerfallow	4.5	(11)
	Zero-Tillage	9.0	(22)
Disker	Summerfallow	3.0	(7)
	Stubble	4.5	(11)
Air Seeder	Summerfallow	4.0	(10)
	with Heavy Duty Cultivator	5.0	(12)
	with Light Duty Cultivator	7.5	(18)
	Duty Cultivator 4 in (100 mm) deep		
with Light Duty Cultivator	Summerfallow	3.5	(9)
	Stubble	4.5	(11)

APPENDIX I

PAMI REPORTS ON SEEDING AND FERTILIZING EQUIPMENT to MARCH, 1988

These reports may be obtained by writing or phoning one of the three PAMI stations.

Chemical Fertilizer Applicators

- 103 Melroe 2710 Fertilizer Attachment
- 176 Spierco M80 Fertilizer Attachment
- 177 Gandy 44-NDK 59 Fertilizer Attachment
- 387 Fertilizer Banding Knife Attachments
- 494 Valmar Model 4400 Fertilizer Attachment
- 495 Spierco 80 Fertilizer Attachment
- 496 Accu Lil Bander Fertilizer Attachment

Grain Drills

- 42 Massey Ferguson 63 Grain Drill
- 43 John Deere 9350 Grain and Fertilizer Drill
- 44 International Harvester 620 Grain and Fertilizer Drill
- 102 John Deere 1500 Power-Till Seeder
- 147 Haybuster 1206 Grain and Fertilizer Drill
- 148 Melroe 702-3D Grain and Fertilizer Drill
- 173 Melroe 282-147 Grain and Fertilizer Drill
- 174 Morris 80-14 Seed Rite Hoe Drill
- 175 Noble DK5 Grain Drill
- 294 Morris M-10 Grain Drill
- 302 Versatile Noble 2000 Seed Drill
- 303 International Harvester 7200 Stubble Mulch Press Drill
- 420 Lilliston 9680 No-Till Grain Drill
- 421 Amazone NT 375 No-Till Grain Drill
- 486 Haybuster 8000 No-Till Grain Drill
- 487 Haybuster 107 No-Till Grain Drill
- 502 Morris MH-310 Hoe Press Drill
- 503 Massey Ferguson 426 Hoe Drill
- 504 Versatile (1985 Model) 2200 Seed Drill
- 508 Connor Shea Coil Tyne Coulter Drill
- 518 GT Versa Drill 1006 No-Till Grain Drill
- 519 Tye Series V 114-5360 No-Till Drill
- 525 Edwards HD812 Hoe Drill

One-Way Disk Harrows

- 198 Massey Ferguson 360 Wide Level Disk Harrow
- 284 International Harvester 310 Diskall
- 285 John Deere 1900 Seeding Tiller
- 295 Co-op implements 1001 Disker

Pneumatic Seeders

- 218 Friggstad PA1-40 Pneumatic Applicator
- 219 Prasco Super Seeder Model 75-55 Pneumatic Applicator
- 220 Wil-Rich 4150 Air Seeder
- 270 John Deere 665 Central Metering Seeder
- 271 Flexi-Coil Air Flow Seeder
- 272 Morris M-600 Air Flow Seeder
- 296 John Shearer Model MK3 Air Seeder
- 297 Leon S-45 Air Seeder
- 298 Bourgault 138D Air Seeder
- 406 Concord Model AS1002 Air Seeder
- 501 Blanchard 5-Way Air Seeder
- 510 Great Plains Model ADC-0285-71 Air Drill
- 514 Hooper Seed Brake Boot

Monitors and Controllers

- 101 SED Model 902 Seeder Monitor
- 349 Senstek DCM-2 Depth Control System
- 363 Jeannotte Depth Controllers
- 469 Microtek Automatic Depth Controller
- 470 Depth Master Automatic Depth Control System

Other monitors tested as part of some seeders.



**ALBERTA
FARM
MACHINERY
RESEARCH
CENTRE**

3000 College Drive South
Lethbridge, Alberta, Canada T1K 1L6
Telephone: (403) 329-1212
FAX: (403) 329-5562
<http://www.agric.gov.ab.ca/navigation/engineering/afmrc/index.html>

Prairie Agricultural Machinery Institute

Head Office: P.O. Box 1900, Humboldt, Saskatchewan, Canada S0K 2A0
Telephone: (306) 682-2555

Test Stations:

P.O. Box 1060

Portage la Prairie, Manitoba, Canada R1N 3C5

Telephone: (204) 239-5445

Fax: (204) 239-7124

P.O. Box 1150

Humboldt, Saskatchewan, Canada S0K 2A0

Telephone: (306) 682-5033

Fax: (306) 682-5080