 Health Canada / Santé Canada	Title of publication-Titre de la publication <b>Product Safety Bureau Reference Manual Book 5 - Laboratory Policies and Procedures</b>	Page <b>M08-1</b>	Effective En vigueur 99-03-26
Chapter and/or Section;-Number and title-Chapitre ou section-Numéro et titre Part B: Test Methods Section, Method M-08 <b>TEST METHOD FOR PLAYPENS</b>			Amendment number- Numéro de la modification 16

## 1 SCOPE

- 1.1 This method describes test procedures for playpens to ensure that the product meets the requirements of the Playpens Regulations. The product is evaluated by performing the following test sections in sequence:
- 4.1 Inspection of information in both official languages
  - 4.2 Inspection of container for damage and labelling
  - 4.3 Permanency of labels
  - 4.4 Indelibility of printing
  - 4.5 Inspection of product for damage and labelling
  - 4.6 Statement of compliance with the regulations
  - 4.7 Assembly of the product in accordance with the instructions supplied
  - 4.8 Determination of mesh strength and integrity of attachment
  - 4.9 Sharp edges and sharp points
  - 4.10 Open holes
  - 4.11 Wheels or casters
  - 4.12 90 N Push/Pull
  - 4.13 Small Components
  - 4.14 Threaded bolt ends
  - 4.15 Attached cord length
  - 4.16 Stability
  - 4.17 Floor support
  - 4.18 Shearing or pinching
  - 4.19 Upper framing member height
  - 4.20 Stitching
  - 4.21 Determination of mesh opening sizes

 Health Canada / Santé Canada	Title of publication-Titre de la publication <b>Product Safety Bureau Reference Manual Book 5 - Laboratory Policies and Procedures</b>	Page <b>M08-2</b>	Effective / En vigueur 99-03-26
Chapter and/or Section;-Number and title-Chapitre ou section-Numéro et titre Part B: Test Methods Section, Method M-08 <b>TEST METHOD FOR PLAYPENS</b>			Amendment number- Numéro de la modification 16

- 1.2 This method is provided to facilitate laboratory procedures only. It is the trader's responsibility to ensure that the product is tested according to, and meets the requirements of the Hazardous Products Act and the Playpens Regulations.

## 2. APPLICABLE DOCUMENTS

- 2.1. The Hazardous Products Act (HPA).
- 2.2. HPA, Playpens Regulations.
- 2.3. Test Method M00.1 Test Procedures to Determine Mechanical Hazards-Small Components-.
- 2.4. Test Method M00.2 Test Procedures to Determine Mechanical Hazards-Sharp Edges-
- 2.5. Test Method M00.3 Test Procedures to Determine Mechanical Hazards-Sharp Points-.

## 3. SAMPLING

- 3.1 The following test procedures are conducted on one specimen.

## 4. TESTING PROCEDURE

### 4.1 INSPECTION OF INFORMATION IN BOTH OFFICIAL LANGUAGES

Examine any information or statement accompanying the product, printed on or permanently affixed to the product or its container to determine if it is in both official languages. Record observations.<sup>1</sup>

### 4.2 INSPECTION OF CONTAINER FOR DAMAGE AND LABELLING

#### 4.2.1 Scope

- 4.2.1.1 This method describes the procedure for determining whether the product container is clearly identified and in an undamaged condition.<sup>2</sup>

#### 4.2.2 Apparatus

- 4.2.2.1 A graduated measuring magnifier.

<sup>1</sup> § 3(2) of the Regulations

<sup>2</sup> § 4(3) of the Regulations

 Health Canada / Santé Canada	Title of publication-Titre de la publication <b>Product Safety Bureau Reference Manual Book 5 - Laboratory Policies and Procedures</b>	Page <b>M08-3</b>	Effective En vigueur 99-03-26
Chapter and/or Section;-Number and title-Chapitre ou section-Numéro et titre <b>Part B: Test Methods Section, Method M-08 TEST METHOD FOR PLAYPENS</b>			Amendment number- Numéro de la modification 16

#### 4.2.3 Procedure

4.2.3.1 Inspect the product container for damage. If damage exists, inspect contents for damage and discontinue testing if the product itself is damaged.

4.2.3.2 Inspect the product container for the following information:

- (i) The name and principal place of business of the person or company by or for whom the product is made;
- (ii) The model name or model number of the product;
- (iii) The month and year of manufacture of the product.

4.2.3.3 Measure the height of the characters used to present the information required in 4.2.3.2. When lower case print is used, the size of the type is determined by measuring the height of the lower case "l" or similar full height letter.

#### 4.2.4 Results

4.2.4.1 Record details of the following:

- (i) Whether the product container was damaged, and if so whether the contents were damaged.
- (ii) Whether the information listed in 4.2.3.2 was present and any discrepancies.
- (iii) The heights of characters less than 2.4 mm.

### 4.3 PERMANENCY OF LABELS

#### 4.3.1 Scope

4.3.1.1 This method describes the procedure for determining whether the labels on the product and container are permanently attached.<sup>3</sup>

#### 4.3.2 Apparatus

4.3.2.1 A knife or scalpel

4.3.2.2 A clamp capable of maintaining its grasp when pulled with a force of 90N.

<sup>3</sup>§ 4(1) to 4(3) of the Regulations

 Health Canada / Santé Canada	Title of publication-Titre de la publication <b>Product Safety Bureau Reference Manual Book 5 - Laboratory Policies and Procedures</b>	Page <b>M08-4</b>	Effective En vigueur 99-03-26
Chapter and/or Section;-Number and title-Chapitre ou section-Numéro et titre <b>Part B: Test Methods Section, Method M-08 TEST METHOD FOR PLAYPENS</b>			Amendment number- Numéro de la modification 16

4.3.2.3 A force gauge capable of measuring 90 N.

#### 4.3.3 Procedure

4.3.3.1 Using a fingernail, knife or scalpel, attempt to raise a portion of the label (a corner is preferred if available) far enough so that the label clamp can be attached. In doing so, care should be taken not to damage the label material or surface on which it is affixed.

4.3.3.2 Attach the label clamp to the raised portion of the label at a point that has not been damaged (torn, frayed, crumpled, etc.) by the raising action.

4.3.3.3 Attach the force gauge to the label clamp and gradually apply a force up to but not exceeding 90 N in an attempt to initiate and sustain removal action of the label. The angle of force application (as close as possible to the horizontal is preferred) may be adjusted to facilitate removal of the label. If the attached portion of the label slips from the clamp, adjust the clamp, re-attach it and the force gauge and resume the test. If the label begins to tear, continue with the test until the torn portion detaches or until the entire label has been completely detached.

#### 4.3.4 Results

4.3.4.1 Record the following:

(i) If a portion of the label could not be raised a sufficient amount to provide an adequate undamaged area to attach the label clamp.

(ii) Whether the label detached completely from the product.

(iii) The maximum force applied.

(iv) Whether the label tore or was damaged during the attempt to remove it from the product.

(v) Whether the surface on which the label was affixed was damaged during the attempt to remove it from the product.

## 4.4 INDELIBILITY OF PRINTING

### 4.4.1 Scope

4.4.1.1 This method describes the procedure for determining whether the written information supplied with the product or on the container is indelible.<sup>4</sup>

<sup>4</sup>§ 4(1) to 4(3) of the Regulations

 Health Canada / Santé Canada	Title of publication-Titre de la publication <b>Product Safety Bureau Reference Manual Book 5 - Laboratory Policies and Procedures</b>	Page <b>M08-5</b>	Effective / En vigueur 99-03-26
Chapter and/or Section;-Number and title-Chapitre ou section-Numéro et titre <b>Part B: Test Methods Section, Method M-08 TEST METHOD FOR PLAYPENS</b>			Amendment number- Numéro de la modification 16

#### 4.4.2 Apparatus

4.4.2.1 A non-abrasive, all-purpose household cleaner, such as Windex or equivalent, used as recommended by its manufacturer.

4.4.2.2 An all-purpose cloth.

#### 4.4.3 Procedure

4.4.3.1 Any required information, statements or instructions which are either:

(i) printed on a label which is glued onto the product or

(ii) printed on plastic or other material affixed to the product or

(iii) stamped on the product or

(iv) printed on the product,

are rubbed 10 times (10 strokes) with an all-purpose cloth which has been sprayed with a non-abrasive, non-acidic window cleaner.

#### 4.4.4 Results

4.4.4.1 Record whether the lettering was smudged or was partially or totally erased.

### 4.5 INSPECTION OF PRODUCT FOR DAMAGE AND LABELLING

#### 4.5.1 Scope

4.5.1.1 This method describes the procedure for determining whether the product is clearly identified.<sup>5</sup>

#### 4.5.2 Apparatus

4.5.2.1 A graduated measuring magnifier.

#### 4.5.3 Procedure

4.5.3.1 Inspect the product for damage.

4.5.3.2 Inspect the product for the following information, which must be clearly identified and displayed:

<sup>5</sup>§ 4(1) of the Regulations

 Health Canada / Santé Canada	Title of publication-Titre de la publication <b>Product Safety Bureau Reference Manual Book 5 - Laboratory Policies and Procedures</b>	Page <b>M08-6</b>	Effective En vigueur 99-03-26
Chapter and/or Section;-Number and title-Chapitre ou section-Numéro et titre <b>Part B: Test Methods Section, Method M-08 TEST METHOD FOR PLAYPENS</b>			Amendment number- Numéro de la modification 16

(i) The name and principal place of business of the person or company by or for whom the product is made;

(ii) The model name or model number of the product;

(iii) The month and year of manufacture of the product.

4.5.3.3 Measure the height of the characters used to present the information required in 4.5.3.2. When lower case print is used, the size of the type is determined by measuring the height of the lower case "l" or similar full height letter.

#### 4.5.4 Results

4.5.4.1 Record details of the following:

(i) Whether the product was damaged.

(ii) Whether the information listed in 4.5.3.2 was present and any discrepancies.

(iii) The heights of characters less than 2.4 mm.

#### 4.6 STATEMENT OF COMPLIANCE WITH THE REGULATIONS

4.6.1 Determine and record if the following statement immediately follows the information required<sup>6</sup> in 4.5 and is clearly and prominently displayed in letters not less than 2.4 mm in height (as defined in 4.5.3.3):

"This product complies with the requirements of the *Playpens Regulations* (Canada)"

#### 4.7 ASSEMBLY OF THE PRODUCT IN ACCORDANCE WITH THE INSTRUCTIONS SUPPLIED

##### 4.7.1 Scope

4.7.1.1 This method describes the procedure for determining whether the product, unless fully assembled, bears or is accompanied by instructions that clearly state and show how the product is to be assembled.<sup>7</sup>

##### 4.7.2 Apparatus

<sup>6</sup> § 4(2) of the Regulations

<sup>7</sup> § 4(4) of the Regulations

 Health Canada Santé Canada	Title of publication-Titre de la publication <b>Product Safety Bureau          Reference Manual          Book 5 - Laboratory Policies and Procedures</b>	Page <b>M08-7</b>	Effective En vigueur 99-03-26
Chapter and/or Section;-Number and title-Chapitre ou section-Numéro et titre <b>Part B: Test Methods Section, Method M-08          TEST METHOD FOR PLAYPENS</b>			Amendment number- Numéro de la modification 16

4.7.2.1 No special test apparatus is required, however, hand tools may be required to complete product assembly.

4.7.3 Procedure

4.7.3.1 Assemble the product according to the manufacturer's instructions.

4.7.4 Results

4.7.4.1 Record whether the product, unless fully assembled, bears or is accompanied by instructions that clearly state and show how the product is to be assembled, and any deficiencies or ambiguities in the instructions.

**4.8 DETERMINATION OF MESH STRENGTH AND INTEGRITY OF ATTACHMENT**

4.8.1 Scope

4.8.1.1 This method describes the procedure for determining whether or not the mesh breaks or ruptures or becomes separated from its supporting structure or attachments.<sup>8</sup>

4.8.2 Apparatus

4.8.2.1 A metal loading block as shown in (Figure 1) having a mass of 9.18 kg (20.23 lbs) and a base measuring 150 mm x 75 mm (5.9 in x 2.9 in).

4.8.2.2 A Stop Watch.

4.8.3 Procedure (Refer to Figure 2)

4.8.3.1 Place the product, assembled in accordance with the manufacturer's instructions, on its side so that its side lies in a horizontal plane.

4.8.3.2 If necessary, apply blocking or support to maintain the position described in subsection 4.8.3.1 as long as the blocking or support does not act directly on the frame of the side under test.

4.8.3.3 Apply the base of the metal loading block to the mesh with the 150 mm (5.9 in) sides running transversely to the side of the playpen, in the following manner:

(i) gradually apply the load over a 1 second period, keeping the rod, connecting the handle to the base of the metal block, vertical;

(ii) maintain the load for 10 seconds;

<sup>8</sup> § 5(2) of the Regulations

 Health Canada / Santé Canada	Title of publication-Titre de la publication <b>Product Safety Bureau Reference Manual Book 5 - Laboratory Policies and Procedures</b>	Page <b>M08-8</b>	Effective En vigueur 99-03-26
Chapter and/or Section;-Number and title-Chapitre ou section-Numéro et titre Part B: Test Methods Section, Method M-08 <b>TEST METHOD FOR PLAYPENS</b>			Amendment number- Numéro de la modification 16

(iii) gradually remove load over a 1 second period; and

(iv) allow a 10 second recovery time.

4.8.3.4 Repeat the loading procedure described in subsection 4.8.3.3 ten times.

4.8.3.5 The loading procedure described in subsection 4.8.3.3 shall be applied to three areas of each side of the playpen as follows and as illustrated in Figure 2:

(i) at the geometric centre of the side or, where exterior framing interferes with the test, perform the test with the test weight as close as possible to the geometric centre;

(ii) near the top rail of the side, with the closer 75 mm (2.9 in ) edge of the load block between 25 mm (1 in) and 50 mm (2 in) from the centre of the rail at the transverse centre line of the panel; and

(iii) near the bottom rail with the closer 75 mm (2.9 in ) edge of the load block between 25 mm (1 in) and 50 mm (2 in) from the centre of the rail at the transverse centre line of the panel.

4.8.4 Results

4.8.4.1 Report any mesh breakage, rupture or separation from its supporting structure or attachments.

#### 4.9 SHARP EDGES AND SHARP POINTS

4.9.1 Conduct these tests as described in Test Method M00.2 Test Procedures to Determine Mechanical Hazards-Sharp Edges-, and Test Method M00.3 Test Procedures to Determine Mechanical Hazards-Sharp Points.<sup>9</sup>

4.9.2 Examine and record the location of every exposed<sup>10</sup> wooden or plastic part of the product that is split, cracked or defective in any other way.

#### 4.10 OPEN HOLES

4.10.1 Scope

<sup>9</sup> § 5(3) and 5(4) of the Regulations

<sup>10</sup> Exposed is interpreted to mean "accessible to the occupant." A component is considered to be occupant-accessible if it is located inside the playpen, including under the removable floor pad. In the case of mesh playpens or similar products whose walls do not permit passage of the occupant's hand or arm, a component is considered accessible if it is located on the outside of the product and within 361 cm of the top rail. In the case of wooden or other playpens whose walls permit the passage of the occupant's hand and arm (rails or other components create gaps more than 3 cm), a component is considered accessible if it is located on the outside of the walls or under the floor of the product within 269 mm of the floor edge, provided the floor is at least 30 mm off the ground.



 Health Canada / Santé Canada	Title of publication-Titre de la publication <b>Product Safety Bureau Reference Manual Book 5 - Laboratory Policies and Procedures</b>	Page <b>M08-9</b>	Effective En vigueur 99-03-26
Chapter and/or Section;-Number and title-Chapitre ou section-Numéro et titre <b>Part B: Test Methods Section, Method M-08 TEST METHOD FOR PLAYPENS</b>			Amendment number- Numéro de la modification 16

4.10.1.1 This method describes the procedure for determining whether any open hole, slot or cavity, of any shape or form, may pose a finger entrapment hazard.<sup>11</sup>

#### 4.10.2 Apparatus

4.10.2.1 A finger intrusion probe (Figure 3)

#### 4.10.3 Procedure

4.10.3.1 Examine the product for open holes of any shape, or form, in a metal, plastic, wooden or similar hard material component that is accessible<sup>12</sup> to an occupant.

4.10.3.2 If found, attempt to insert each end of the finger intrusion probe into the hole.

#### 4.10.4 Results

4.10.4.1 Record the location of any hole which admitted the 3.0 mm diameter end of the finger intrusion probe but which did not also admit the 10 mm diameter end of the finger intrusion probe. Record whether the hole was drilled.

4.10.4.2 Record the depth and minor dimension of any hole which admitted the 3.0 mm diameter end of the finger intrusion probe but not the 10 mm diameter end of the probe.

### 4.11 WHEELS OR CASTERS

4.11.1 Examine the product to ensure that it is not equipped with more than two wheels or casters or provisions for the attachment of more than two wheels or casters. Record observations.<sup>13</sup>

### 4.12 90 N PUSH/PULL

#### 4.12.1 Scope

4.12.1.1 This method describes the procedure for determining that,

<sup>11</sup> § 5(7) of the Regulations

<sup>12</sup> See footnote 10

<sup>13</sup> § 5(8) of the Regulations

 Health Canada / Santé Canada	Title of publication-Titre de la publication <b>Product Safety Bureau Reference Manual Book 5 - Laboratory Policies and Procedures</b>	Page <b>M08-10</b>	Effective En vigueur 99-03-26
Chapter and/or Section;-Number and title-Chapitre ou section-Numéro et titre Part B: Test Methods Section, Method M-08 <b>TEST METHOD FOR PLAYPENS</b>			Amendment number- Numéro de la modification 16

(i) every component or piece thereof of the product that could possibly fit in the Truncated Right Circular Cylinder and

(ii) every cap or similar item that protects the edges of metal tubing that are accessible<sup>14</sup> to an occupant of the product;

shall be so fitted or affixed to the product that the component will not become detached when subjected to a force of 90 N applied in any direction<sup>15</sup>.

#### 4.12.2 Apparatus

- 4.12.2.1 A two-pronged clamp.
- 4.12.2.2 A pair of combination pliers.
- 4.12.2.3 A pair of long-nosed pliers.
- 4.12.2.4 A Truncated Right Circular Cylinder.
- 4.12.2.5 A force gauge capable of measuring 90 N.

#### 4.12.3 Procedure

- 4.12.3.1 Using a 90 N force applied in any direction, attempt to remove all components suspected of fitting into the small parts cylinder.
- 4.12.3.2 Attempt to remove all caps or similar items that protect the cut ends of metal tubing, that are accessible to an occupant of the product, with a 90 N force applied in any direction. If successful, subject the cut ends of the metal tubing to the tests referred to in 4.9.

#### 4.12.4. Results

- 4.12.4.1 Report whether any component became detached with a force of 90 N or less.
- 4.12.4.2 Report the actual force required to detach any component.

### 4.13 SMALL COMPONENTS

---

<sup>14</sup>See footnote 10

<sup>15</sup>§ 17 and Schedule IV of the Regulations

 Health Canada / Santé Canada	Title of publication-Titre de la publication <b>Product Safety Bureau Reference Manual Book 5 - Laboratory Policies and Procedures</b>	Page <b>M08-11</b>	Effective En vigueur 99-03-26
Chapter and/or Section;-Number and title-Chapitre ou section-Numéro et titre <b>Part B: Test Methods Section, Method M-08 TEST METHOD FOR PLAYPENS</b>			Amendment number- Numéro de la modification 16

4.13.1 Conduct this test as described in Test Method M00.1 Test Procedures to Determine Mechanical Hazards-Small Components- on any components that were detached during test 4.12.<sup>16</sup>

#### 4.14 THREADED BOLT ENDS

##### 4.14.1 Scope

4.14.1.1 This method describes the procedure for determining that there are no exposed threaded bolt ends.<sup>17</sup>

##### 4.14.2 Procedure

4.14.2.1 Inspect the product's bolt ends for which contact by the occupant can occur.<sup>18</sup>

##### 4.14.3 Results

4.14.3.1 Record every threaded bolt end for which contact by the occupant can occur which is not protected by an acorn nut or other suitable device.

#### 4.15 ATTACHED CORD LENGTH

##### 4.15.1 Scope

4.15.1.1 This method describes the procedure for determining that there is no cord, tape or similar material having a free, stretched length in excess of 180 mm (7.10 in) attached to the product.<sup>19</sup>

##### 4.15.2 Apparatus

4.15.2.1 A tape measure.

4.15.2.2 A clamp capable of maintaining its grasp when pulled with a force of 90N.

4.15.2.3 A force gauge capable of measuring 90 N.

<sup>16</sup> § 5(9) of the Regulations

<sup>17</sup> § 5(5) of the Regulations

<sup>18</sup> See footnote 10

<sup>19</sup> § 5(10) of the Regulations

 Health Canada / Santé Canada	Title of publication-Titre de la publication <b>Product Safety Bureau Reference Manual Book 5 - Laboratory Policies and Procedures</b>	Page <b>M08-12</b>	Effective En vigueur 99-03-26
Chapter and/or Section;-Number and title-Chapitre ou section-Numéro et titre <b>Part B: Test Methods Section, Method M-08 TEST METHOD FOR PLAYPENS</b>			Amendment number- Numéro de la modification 16

#### 4.15.3 Procedure

4.15.3.1 Inspect the product for any cords, tapes or similar materials that can form a loop either by itself or in conjunction with other product components.

**For cords, tapes or similar materials that can form a loop by themselves:**

4.15.3.2 With the end of the cord, tape or similar material clamped, attach the force gauge to the clamp and apply a 90 N pull force.

4.15.3.3 While maintaining the 90 N pull force, measure the stretched length of the cord, tape or similar material.

**For cords, tapes or similar materials that can only form a loop in conjunction with other product components:**

4.15.3.4 Measure the circumference of any loop formed by a cord, tape or similar material in conjunction with other product components when pulled to its maximum length by stretching.

#### 4.15.4 Results

4.15.4.1 Record the linear measurement(s) in 4.15.3.3 and the type and location of the cord(s), tape(s) or similar material(s).

4.15.4.2 Record the circumference(s) in 4.15.3.4 and the type and location of the cord(s), tape(s), similar material(s) and other product components.

### 4.16 STABILITY

#### 4.16.1 Scope

4.16.1.1 This test is conducted to ensure that any locking device or other design feature prevents the product from folding or collapsing spontaneously and that all its support points remain in contact with the inclined plane.<sup>20</sup>

#### 4.16.2 Apparatus

4.16.2.1 A sheet, 19 mm (0.75 inch) thick, of plywood of such size that all the support points of the product are at least 50 mm (1.97 inches) from any edge of the plywood. If necessary, the underside of the plywood can be reinforced to minimize flexure.

4.16.2.2 Stability Test Device (Figure 4)

<sup>20</sup> § 5(11) and 5(17) of the Regulations

 Health Canada / Santé Canada	Title of publication-Titre de la publication <b>Product Safety Bureau Reference Manual Book 5 - Laboratory Policies and Procedures</b>	Page <b>M08-13</b>	Effective En vigueur 99-03-26
Chapter and/or Section;-Number and title-Chapitre ou section-Numéro et titre <b>Part B: Test Methods Section, Method M-08 TEST METHOD FOR PLAYPENS</b>			Amendment number- Numéro de la modification 16

4.16.2.3 A protractor

4.16.2.4 Device to raise one side of the plywood

4.16.2.5 Feeler Gauge or other suitable measuring device

#### 4.16.3 Procedure

4.16.3.1 Assemble the playpen in accordance with the manufacturer's instructions.

4.16.3.2 Place the playpen on the horizontal plywood sheet so that one set of support points or legs in the same plane is parallel to the edge of the plywood.

4.16.3.3 Measure the distances between the corner support points as well as the distance (diagonally) between opposite support points.

4.16.3.4 Measure the vertical heights between the lowest surface of the product support point and the plywood sheet for any support point that is not in contact with the plywood sheet.

4.16.3.5 Place the Stability Test Device on the floor of the playpen so that the longer 300 mm (11.8 inches) edge is parallel to, centred along and as close as possible to the side of the product that is parallel to the edge of the plywood.

4.16.3.6 Measure the vertical heights between the lowest surface of the product support point and the plywood sheet for any support point that is not in contact with the plywood sheet.

4.16.3.7 Tilt the parallel edge of the plywood by raising the side opposite to the plane of the selected support points being tested until it forms a 10° angle with the horizontal. The edges of the support points may be blocked to prevent slippage as long as the blockage does not impede the test.

4.16.3.8 Measure the vertical heights between the lowest surface of the product support point and the plywood sheet for any support point that does not remain in contact with the plywood sheet.

4.16.3.9 Remove the Stability Test Device.

4.16.3.10 Rotate the product such that another set of support points or legs are in the position stated in 4.16.3.2.

4.16.3.11 Repeat steps 4.16.3.3 through 4.16.3.11 until each set of support points or legs have been tested.

#### 4.16.4 Results

 Health Canada / Santé Canada	Title of publication-Titre de la publication <b>Product Safety Bureau Reference Manual Book 5 - Laboratory Policies and Procedures</b>	Page <b>M08-14</b>	Effective En vigueur 99-03-26
Chapter and/or Section;-Number and title-Chapitre ou section-Numéro et titre <b>Part B: Test Methods Section, Method M-08 TEST METHOD FOR PLAYPENS</b>			Amendment number- Numéro de la modification 16

- 4.16.4.1 Record the distances measured in 4.16.3.3 and the locations.
- 4.16.4.2 Record the distances measured in 4.16.3.4 and the locations.
- 4.16.4.3 Record the distances measured in 4.16.3.6 and the locations.
- 4.16.4.4 Record the distances measured in 4.16.3.8 and the locations.
- 4.16.4.5 Record any spontaneous folding or collapsing of the product.
- 4.16.4.6 Record the sum of the maximum distance between support points as measured along the sides of the playpen and the maximum diagonal measurement as measured in 4.16.3.3. Record the product of this sum and 0.00175. This will give the value of possible error introduced by the protractor's least significant digit. (The resolution and stated accuracy of the digital protractor currently used by the Product Safety Laboratory is  $\pm 0.1$  degree).

#### 4.17 FLOOR SUPPORT

##### 4.17.1 Scope

- 4.17.1.1 This method describes the procedure for determining if any portion of the floor of the product is capable of supporting a load of 220 N uniformly distributed over an area of  $4.5 \times 10^4 \text{ mm}^2$  for a period of 1 minute without suffering visually perceptible damage to the product or any component thereof.<sup>21</sup>

##### 4.17.2 Apparatus

- 4.17.2.1 A metal block having a mass of 22.4 kg (49.4 lbs) and a contact surface area of  $4.5 \times 10^4 \text{ mm}^2$  (69.75 square inches).

##### 4.17.3 Procedure

- 4.17.3.1 Place the load block on the playpen floor, where it appears to be weakest, and allow the load to rest for a period of 60 seconds. Repeat the procedure for all other potentially weak places on the playpen floor.

##### 4.17.4 Results

- 4.17.4.1 Record any visually perceptible damage to the product or any component thereof.

---

<sup>21</sup> § 5(12) of the Regulations

 Health Canada / Santé Canada	Title of publication-Titre de la publication <b>Product Safety Bureau Reference Manual Book 5 - Laboratory Policies and Procedures</b>	Page <b>M08-15</b>	Effective / En vigueur 99-03-26
Chapter and/or Section;-Number and title-Chapitre ou section-Numéro et titre Part B: Test Methods Section, Method M-08 <b>TEST METHOD FOR PLAYPENS</b>			Amendment number- Numéro de la modification 16

## 4.18 SHEARING OR PINCHING

### 4.18.1 Scope

4.18.1.1 This method describes the procedure for determining whether any components, pivots, hinges, locks or mechanisms accessible<sup>22</sup> to the occupant pose a possibility of scissoring, shearing or pinching<sup>23</sup>.

### 4.18.2 Apparatus

4.18.2.1 A 3.0 mm diameter probe. (Figure 5)

4.18.2.2 A 15.0 mm diameter probe. (Figure 5)

### 4.18.3 Procedure

4.18.3.1 Visually inspect the product for occupant accessible spaces at or near the intersections of components that move relative to one another.

4.18.3.2 Attempt to insert the 3.0 mm diameter probe into these spaces in any and all positions of the moving components.

4.18.3.3 Attempt to insert the 15.0 mm diameter probe into these spaces in any and all positions of the moving components.

4.18.3.4 If the 3.0 mm diameter probe can be inserted into the space and the 15.0 mm diameter probe cannot be inserted into the space as described in 4.18.3.2 and 4.18.3.3, measure the dimensions of the open space.

### 4.18.4 Results

4.18.4.1 Record the locations of any space that allowed the 3.0 mm diameter probe to enter but would not also allow entry of the 15.0 mm diameter probe upon subsequent manipulation of the components forming the space.

4.18.4.2 Record the dimensions within intersecting parts of these spaces.

## 4.19 UPPER FRAMING MEMBER HEIGHT

### 4.19.1 Scope

<sup>22</sup> See footnote 10

<sup>23</sup> § 19 of the Regulations. (Based on the "Components Test" for scissoring, shearing and pinching hazards of section 6.6 in ASTM F 406-97 - Standard Consumer Safety Specification for Play Yards)

 Health Canada / Santé Canada	Title of publication-Titre de la publication <b>Product Safety Bureau Reference Manual Book 5 - Laboratory Policies and Procedures</b>	Page <b>M08-16</b>	Effective / En vigueur 99-03-26
Chapter and/or Section;-Number and title-Chapitre ou section-Numéro et titre <b>Part B: Test Methods Section, Method M-08 TEST METHOD FOR PLAYPENS</b>			Amendment number- Numéro de la modification 16

4.19.1.1 This method describes the procedure for determining whether the product offers adequate containment of the occupant.<sup>24</sup>

4.19.2 Apparatus

4.19.2.1 A tape measure.

4.19.3 Procedure

4.19.3.2 Measure the distance between the top of the playpen floor and the lowest point along the top of the upper framing member of the product.

4.19.4 Results

4.19.4.1 Record the distance measured in 4.19.3.2.

**4.20 STITCHING**

4.20.1 Scope

4.20.1.1 This method describes the procedure for checking the playpen stitching.<sup>25</sup>

4.20.2 Apparatus

4.20.2.1 A knife with a sharp pointed blade.

4.20.2.2 A force gauge capable of measuring 90 N.

4.20.2.3 A device to grasp the cut end of the stitching.

4.20.3 Procedure

4.20.3.1 Cut the playpen stitching in several places and apply a 90 N pull force on the cut end to see if it unravels. Stitching should be Lock Stitching as illustrated in Figure 6.

4.20.4 Results

4.20.4.1 Record whether any pulled end of stitching resulted in the undoing of one or more stitches.

---

<sup>24</sup> § 5(14) of the Regulations

<sup>25</sup> § 5(15) of the Regulations



 Health Canada / Santé Canada	Title of publication-Titre de la publication <b>Product Safety Bureau Reference Manual Book 5 - Laboratory Policies and Procedures</b>	Page <b>M08-17</b>	Effective En vigueur 99-03-26
Chapter and/or Section;-Number and title-Chapitre ou section-Numéro et titre Part B: Test Methods Section, Method M-08 <b>TEST METHOD FOR PLAYPENS</b>			Amendment number- Numéro de la modification 16

## 4.21 DETERMINATION OF MESH OPENING SIZES

### 4.21.1 Scope

4.21.1.1 This method describes the procedure for determining whether or not the tip of a simulated button probe is capable of passing through an opening in the product's mesh.<sup>26</sup>

### 4.21.2 Apparatus

4.21.2.1 Button Probe (Figure 7).

4.21.2.2 A template 305 x 305 mm (one foot square).

4.21.2.3 A 2.2 kg (4.95 lbs) mass (in combination with the mass of the Probe).

4.21.2.4 Universal Test Stand as shown in (Figure 8).

4.21.2.5 A 4.5 kg (10 lbs) mass.

4.21.2.6 A Stopwatch.

4.21.2.7 A knife or scissors.

4.21.2.8 A microscope.

4.21.2.9 A Polaroid camera.

### 4.21.3 Procedure

4.21.3.1 Place the 305 x 305 mm (1 foot square) template against the mesh of the properly erected playpen such that one edge of the template is parallel with the floor. Mark around the outer edges of the template with an indelible felt marker pen. Remove the template and cut out the marked sample of the mesh.

4.21.3.2 Clamp two opposite edges of the cut specimen in the Universal Test Stand.

4.21.3.3 Hang the 4.5 Kg mass onto the looped end of the string that is connected to the centre of the adjustable sliding clamp of the Universal Test Stand.

4.21.3.4 Within 75 mm (3 inches) from all four edges of the cut specimen, randomly select 10 openings and mark them on the mesh. If more than one size of opening exists, include all different sizes in the 10 openings selected.

<sup>26</sup> § 5(1) of the Regulations

 Health Canada / Santé Canada	Title of publication-Titre de la publication <b>Product Safety Bureau Reference Manual Book 5 - Laboratory Policies and Procedures</b>	Page <b>M08-18</b>	Effective En vigueur 99-03-26
Chapter and/or Section;-Number and title-Chapitre ou section-Numéro et titre <b>Part B: Test Methods Section, Method M-08 TEST METHOD FOR PLAYPENS</b>			Amendment number- Numéro de la modification 16

- 4.21.3.5 While standing on “Side A” (see Figure 8) of the Universal Test Stand, pass the twine loop of the probe downward through one of the selected holes. Lay the probe shaft to rest horizontally on the mesh in an orientation that allows the probe tip to lay directly across the width of the mesh opening that would be the maximum width opening when subsequently stretched under load in the next step.
- 4.21.3.6 Attach the 2.2 kg (4.95 lb) mass to the twine loop and release slowly. Allow the probe shaft to move unrestricted in response to the attached mass.
- 4.21.3.7 Remove the mass after 10 seconds have elapsed.
- 4.21.3.8 Repeat steps 4.21.3.5 to 4.21.3.7 for each of the remaining marked openings.
- 4.21.3.9 Remove the hanging masses and remove the mesh specimen from the clamps. Clamp the other two opposite edges of the mesh specimen in the Universal Test Stand.
- 4.21.3.10 Repeat steps 4.21.3.3 through 4.21.3.8. Ensure to randomly select and mark a new set of 10 openings. Use a different colour marker to identify the 10 new mesh openings.
- 4.21.3.11 If the probe tip passed through any opening, examine the fibres under the microscope and take a Polaroid picture of them. Using a pair of scissors, cut the fibres of an unmarked opening in the mesh specimen. Position this opening under the microscope and take a Polaroid picture of the cut fibres. Appropriately label the Polaroid pictures and attach them to the sample file folder.

#### 4.21.4 Results

- 4.21.4.1 Record whether or not the probe tip was capable of passing through a mesh opening without cutting the fibres of the material and the number of seconds that elapsed before such an occurrence.

## 5 QUALITY ASSURANCE/QUALITY CONTROL PROCEDURES

- 5.1 Ensure that all measuring instruments are functional and are calibrated.
- 5.2 The Quality Control section of the test method is under development and will be added in a revised issue when completed.

 Health Canada Santé Canada	Title of publication-Titre de la publication <b>Product Safety Bureau          Reference Manual          Book 5 - Laboratory Policies and Procedures</b>	Page <b>M08-19</b>	Effective En vigueur 99-03-26
Chapter and/or Section;-Number and title-Chapitre ou section-Numéro et titre Part B: Test Methods Section, Method M-08 <b>TEST METHOD FOR PLAYPENS</b>			Amendment number- Numéro de la modification 16

## 6 TEST REPORT

- 6.1 The test report shall contain the following information:
- 6.1.1 A description of the product to include brand, style, country of origin, size and UPC.
  - 6.1.2 The number of sample elements tested.
  - 6.1.3 The results of the test conducted as described by section 4 of this test method in sequence (see Appendix for standard report format).
  - 6.1.4 The analyst's name and signature.
  - 6.1.5 The signature of the approving officer.

 Health Canada / Santé Canada	Title of publication-Titre de la publication <b>Product Safety Bureau          Reference Manual          Book 5 - Laboratory Policies and Procedures</b>	Page <b>M08-20</b>	Effective En vigueur 99-03-26
Chapter and/or Section;-Number and title-Chapitre ou section-Numéro et titre Part B: Test Methods Section, Method M-08 <b>TEST METHOD FOR PLAYPENS</b>			Amendment number- Numéro de la modification 16

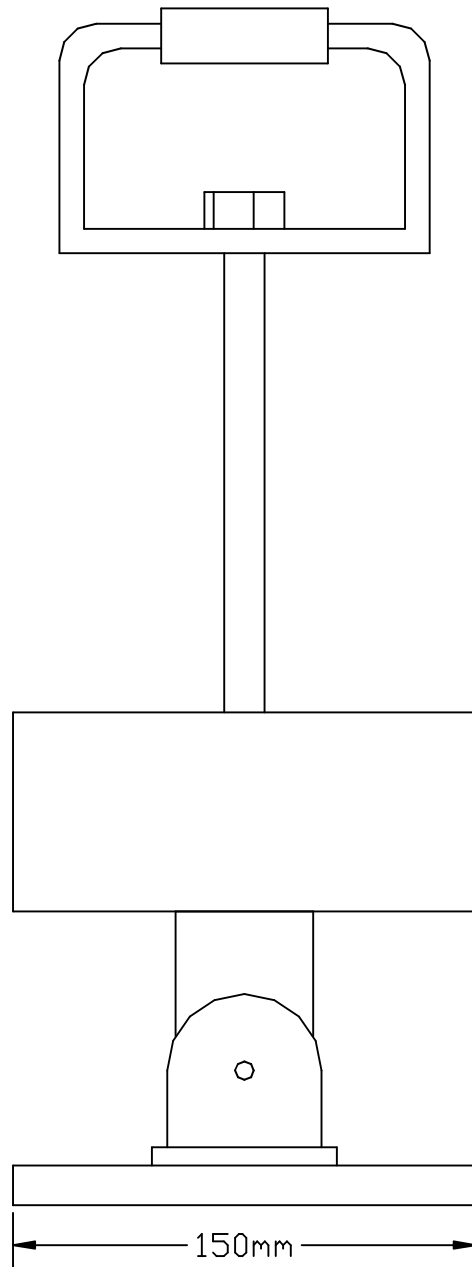

**Figure 1 - 9.18 kg loading block on 150 mm x 75 mm base.**

 Health Canada / Santé Canada	Title of publication-Titre de la publication <b>Product Safety Bureau          Reference Manual          Book 5 - Laboratory Policies and Procedures</b>	Page <b>M08-21</b>	Effective En vigueur 99-03-26
Chapter and/or Section;-Number and title-Chapitre ou section-Numéro et titre Part B: Test Methods Section, Method M-08 <b>TEST METHOD FOR PLAYPENS</b>			Amendment number- Numéro de la modification 16

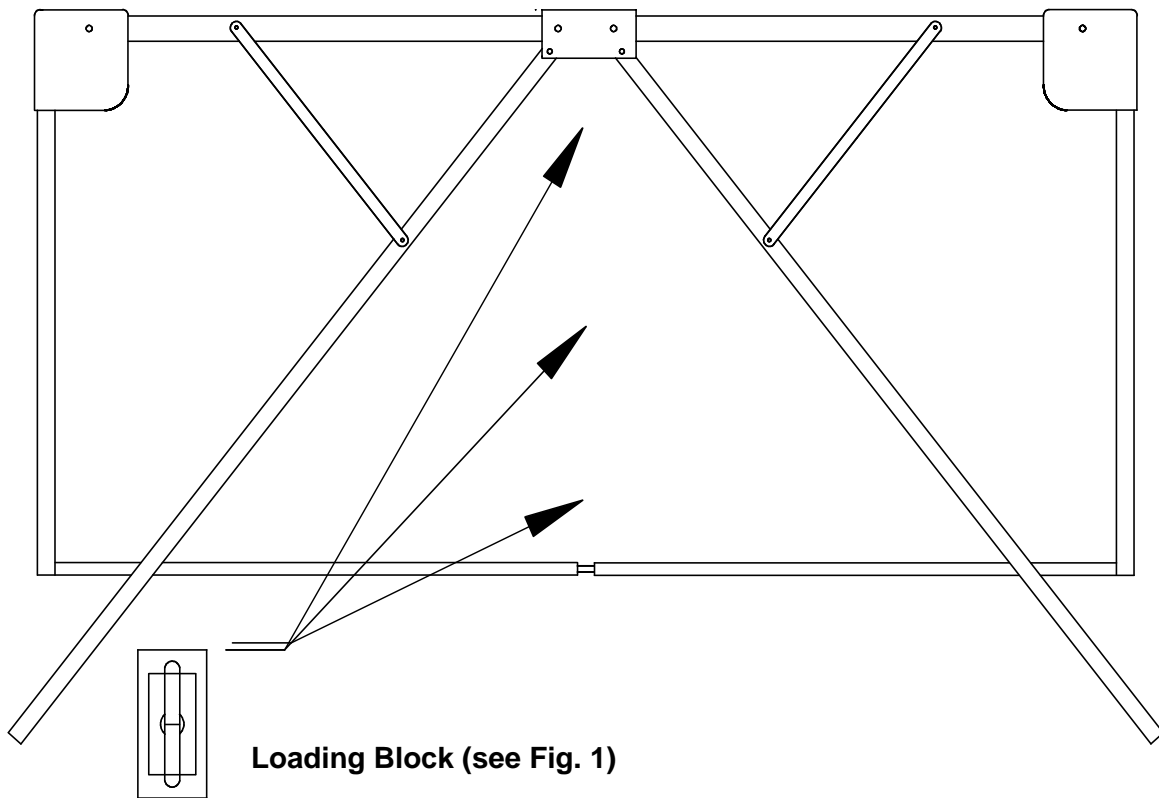

**Figure 2 - Location of Loading areas on sides of playpens**

 Health Canada / Santé Canada	Title of publication-Titre de la publication <b>Product Safety Bureau          Reference Manual          Book 5 - Laboratory Policies and Procedures</b>	Page <b>M08-22</b>	Effective En vigueur 99-03-26
Chapter and/or Section;-Number and title-Chapitre ou section-Numéro et titre Part B: Test Methods Section, Method M-08 <b>TEST METHOD FOR PLAYPENS</b>			Amendment number- Numéro de la modification 16

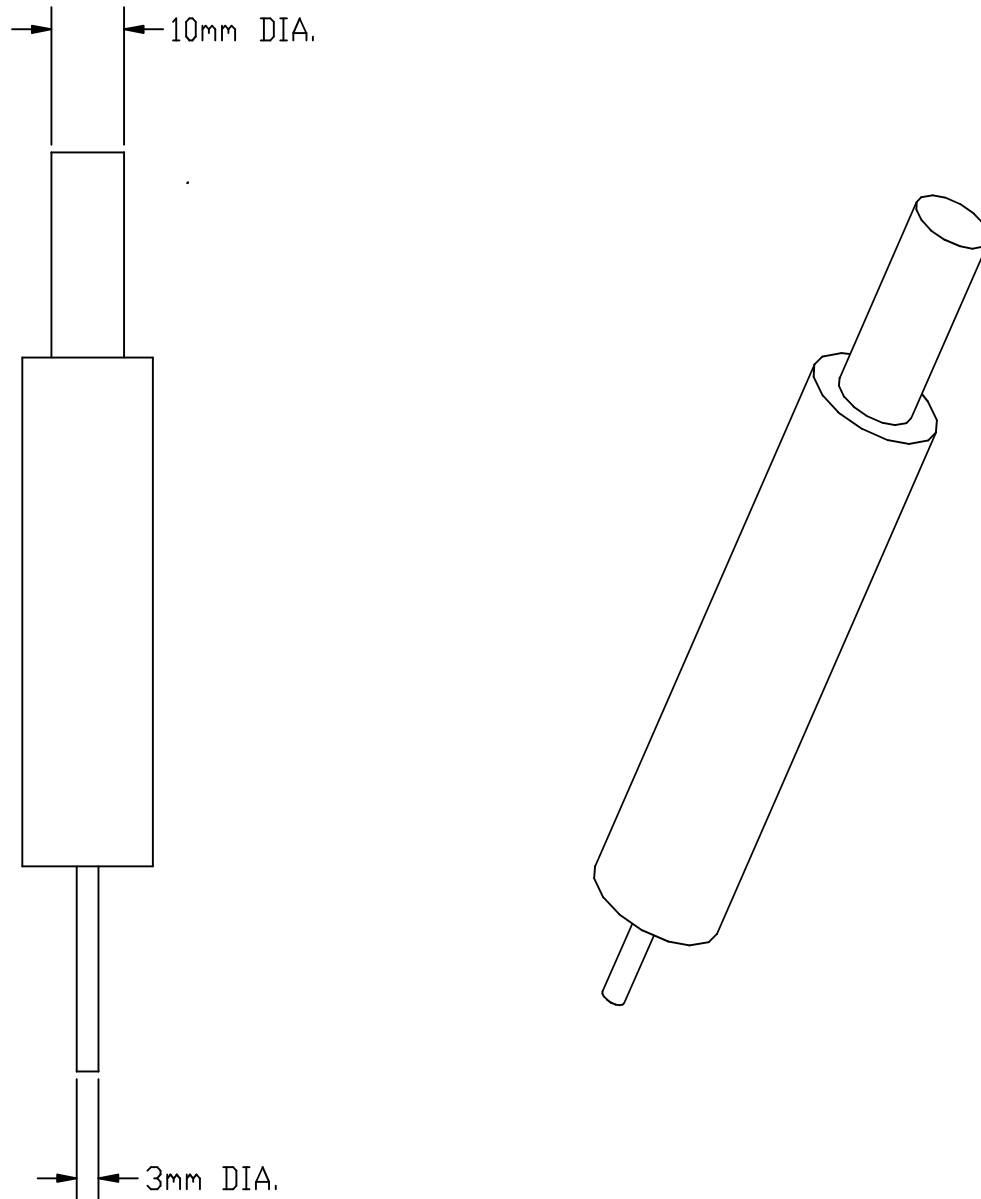

**Figure 3 - Finger Intrusion Probe**

 Health Canada / Santé Canada	Title of publication-Titre de la publication <b>Product Safety Bureau          Reference Manual          Book 5 - Laboratory Policies and Procedures</b>	Page <b>M08-23</b>	Effective / En vigueur 99-03-26
Chapter and/or Section;-Number and title-Chapitre ou section-Numéro et titre Part B: Test Methods Section, Method M-08 <b>TEST METHOD FOR PLAYPENS</b>			Amendment number- Numéro de la modification 16

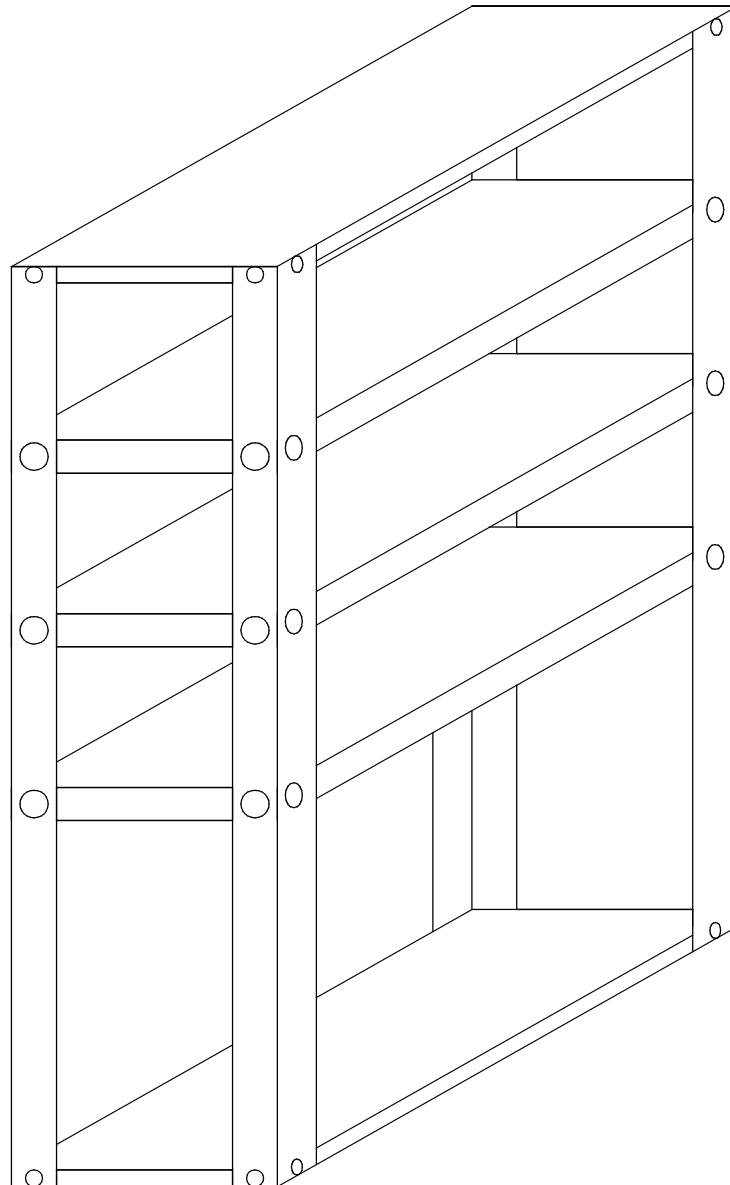

**Figure 4 - Stability Test Device**  
 (Bolted design shown, refer to Schedule VI of the  
 Playpen Regulations for Specification)

 Health Canada / Santé Canada	Title of publication-Titre de la publication <b>Product Safety Bureau          Reference Manual          Book 5 - Laboratory Policies and Procedures</b>	Page <b>M08-24</b>	Effective En vigueur 99-03-26
Chapter and/or Section;-Number and title-Chapitre ou section-Numéro et titre Part B: Test Methods Section, Method M-08 <b>TEST METHOD FOR PLAYPENS</b>			Amendment number- Numéro de la modification 16

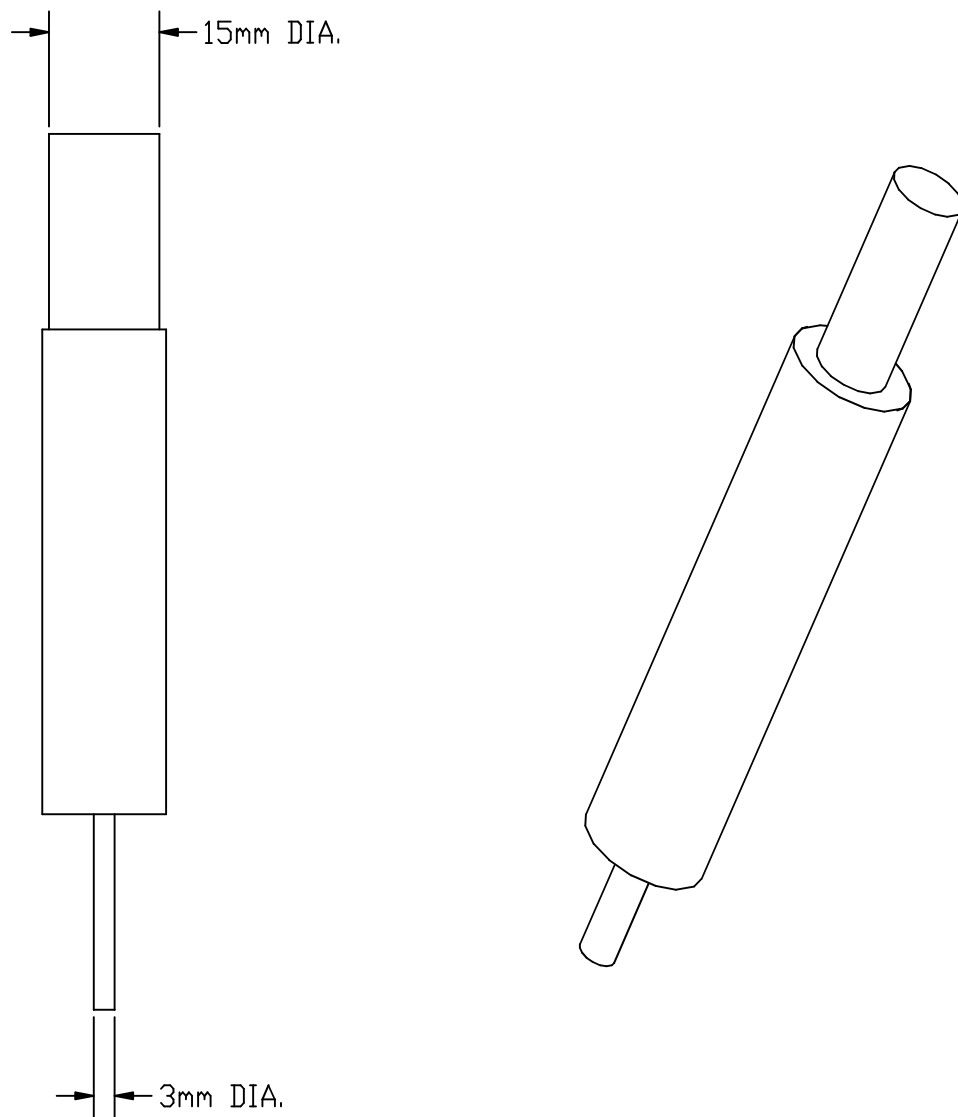

**Figure 5 - 3 mm and 15 mm Diameter Probe**



 Health Canada / Santé Canada	Title of publication-Titre de la publication <b>Product Safety Bureau          Reference Manual          Book 5 - Laboratory Policies and Procedures</b>	Page <b>M08-25</b>	Effective En vigueur 99-03-26
Chapter and/or Section;-Number and title-Chapitre ou section-Numéro et titre Part B: Test Methods Section, Method M-08 <b>TEST METHOD FOR PLAYPENS</b>			Amendment number- Numéro de la modification 16

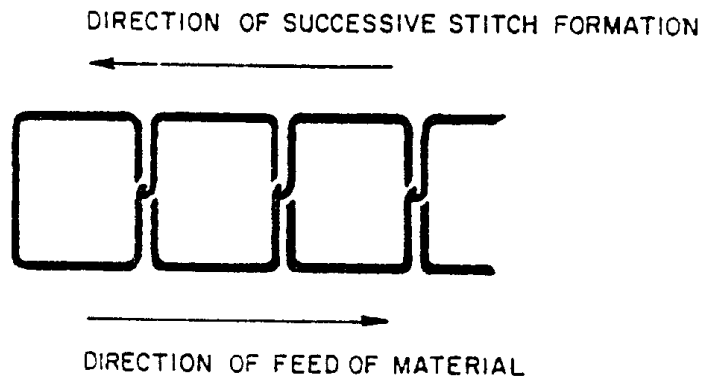

TWO-THREADED LOCKSTITCH FORMED FROM A SINGLE  
 THREAD SOURCE. U.S. FEDERAL STITCH TYPE 701.

**Figure 6 - Two-Threaded Lockstitch**

 Health Canada / Santé Canada	Title of publication-Titre de la publication <b>Product Safety Bureau          Reference Manual          Book 5 - Laboratory Policies and Procedures</b>	Page <b>M08-26</b>	Effective En vigueur 99-03-26
Chapter and/or Section;-Number and title-Chapitre ou section-Numéro et titre Part B: Test Methods Section, Method M-08 <b>TEST METHOD FOR PLAYPENS</b>			Amendment number- Numéro de la modification 16

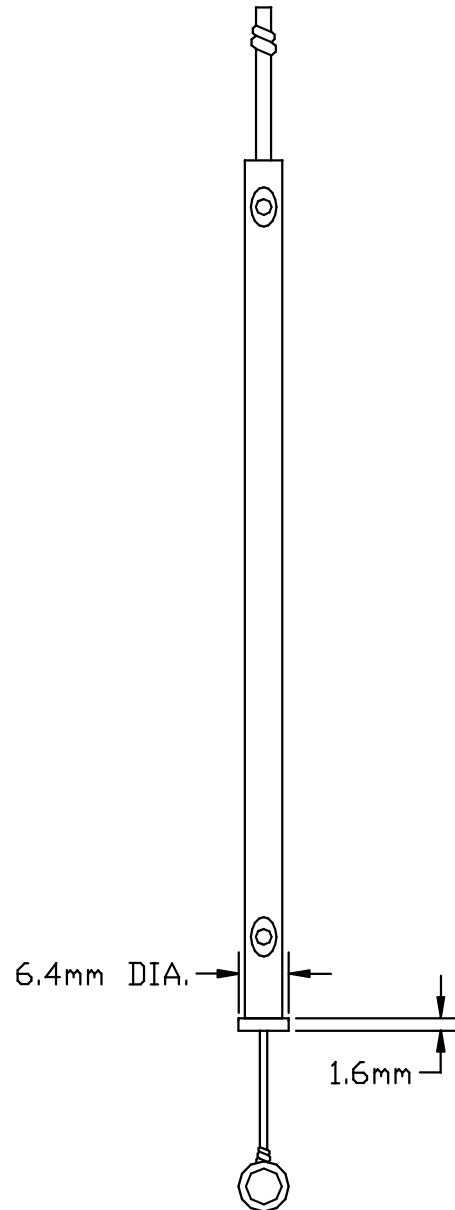

**Figure 7 - Button Probe**

 Health Canada / Santé Canada	Title of publication-Titre de la publication <b>Product Safety Bureau          Reference Manual          Book 5 - Laboratory Policies and Procedures</b>	Page <b>M08-27</b>	Effective En vigueur 99-03-26
Chapter and/or Section;-Number and title-Chapitre ou section-Numéro et titre Part B: Test Methods Section, Method M-08 <b>TEST METHOD FOR PLAYPENS</b>			Amendment number- Numéro de la modification 16

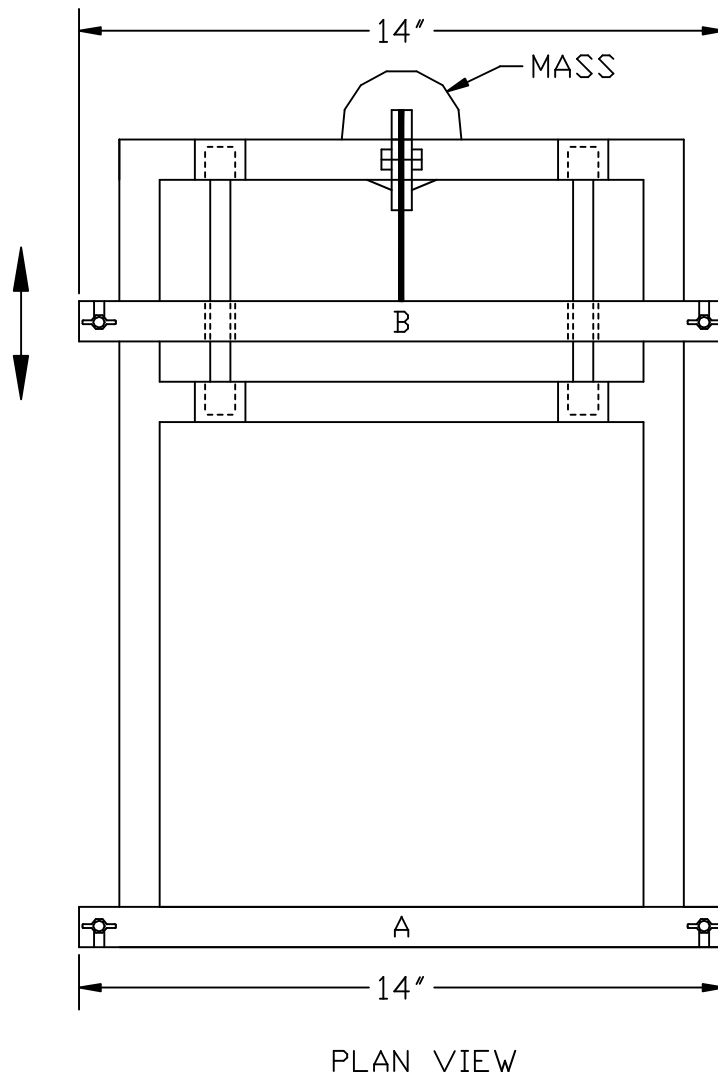

**Figure 8 - Universal Test Stand**

 Health Canada / Santé Canada	Title of publication-Titre de la publication <b>Product Safety Bureau          Reference Manual          Book 5 - Laboratory Policies and Procedures</b>	Page <b>M08-28</b>	Effective / En vigueur 99-03-26
Chapter and/or Section;-Number and title-Chapitre ou section-Numéro et titre Part B: Test Methods Section, Method M-08 <b>TEST METHOD FOR PLAYPENS</b>			Amendment number- / Numéro de la modification 16

## APPENDIX

### STANDARD REPORT FORMAT

The standard report format is currently under revision and will be added when complete.