

| | | | |
|--|---|-----------------|--|
|  Health Santé Canada Canada | Title of publication-Titre de la publication Product Safety Reference Manual Book 5 - Laboratory Policies and Procedures | Page C23.3-1 | Effective En vigueur 2003-03-06 |
| Chapter and/or Section;-Number and title-Chapitre ou section-Numéro et titre Part B: Test Methods Section, Method C-23.3 DETERMINATION OF THE FLAME PROJECTION AND FLASHBACK OF CONTROLLED PRODUCTS | | | Amendment number- Numéro de la modification 31 |

1 SCOPE

- 1.1 This method describes a procedure for the determination of the flashback and the length of flame projection for materials and substances packaged in aerosol containers as described in Schedule VI of SOR/88-66 of the Controlled Products Regulations.

2 APPLICABLE DOCUMENTS

- 2.1 Controlled Products Regulations, SOR/88-66, P.C. 1987-2721 31 December, 1987. Schedule VI, "Test for Determining the Flashback and the Length of the Flame Projection of Products, Materials and Substances Packaged in Aerosol Containers.
- 2.2 Project #2002-0654, Determination of the Flame Projection and Flashback of Consumer Products Packaged in Pressurized Containers. Andrée Soucy and Carrie Watson. 2002-05-01.
- 2.3 Standard for: Cloth, Cotton, and Cheesecloth; CGSB-4-GP-81M.

3 APPARATUS

- 3.1 Flammability tester, as illustrated in Figure 1, that
- 3.1.1 is designed so that the aerosol container can be secured in place by means of a device, such as a three-pronged clamp affixed to a ring stand or a suitable equivalent, in such a manner that the discharge from the container is in the horizontal plane,
 - 3.1.2 may include a device by which the valve of any aerosol container can be activated by remote control (*Note 1*),
 - 3.1.3 has a vertically mounted burner
 - 3.1.3.1 that has an inside diameter of 1.2 mm (*Note 2*),
 - 3.1.3.2 that is placed at a distance of 15 cm from the discharge orifice of the aerosol container, such distance to be measured horizontally between the vertical planes of the discharge orifice and the burner orifice,
 - 3.1.3.3 that is adjustable in both the horizontal and vertical planes,
 - 3.1.4 has two support frameworks
 - 3.1.4.1 each having an internal open space 35 cm wide by 45 cm high, constructed from metal or other non-flammable material and mounted in a vertical plane perpendicular to the direction of discharge from the aerosol container, one being at a distance of 15 cm and the other at a

Note 1: A side-pull, caliper type bicycle hand brake fitted with a push rod has been found satisfactory for this purpose.

Note 2: A 16 gauge Luer-Lock syringe needle affixed to metal tubing has been found satisfactory for this purpose.



Chapter and/or Section;-Number and title-Chapitre ou section-Numéro et titre

Part B: Test Methods Section, Method C-23.3
DETERMINATION OF THE FLAME PROJECTION AND FLASHBACK OF CONTROLLED PRODUCTS

Amendment
number-
Numéro de la
modification
31

distance of 45 cm from the burner and both being on the opposite side of the burner from the container,
3.1.4.2 that are adjustable in both the horizontal and vertical planes.

Figure 1. Flammability Tester

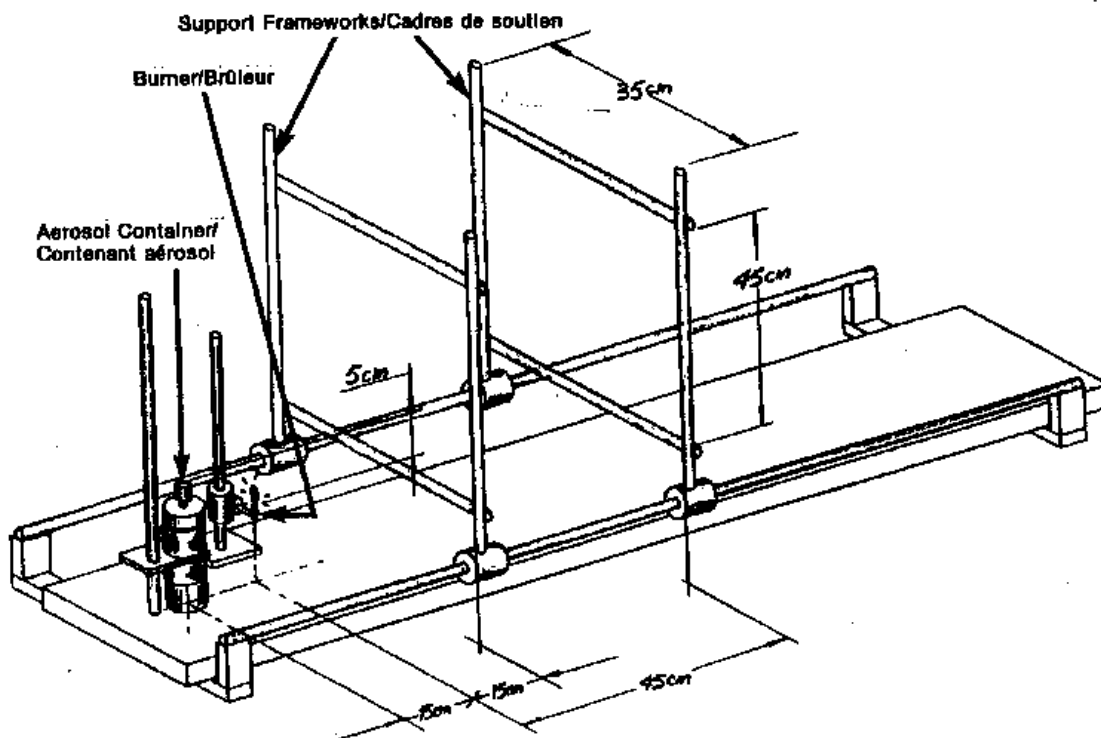

- 3.2 n-Butane gas cylinder (C.P. grade) fitted with a regulator capable of delivering pressure to the burner appropriate to maintaining a flame height as specified in par. 7.3.
- 3.3 Loosely woven cotton fabric commonly referred to as cheesecloth that has, in the bleached state, a mass per unit area of not less than 35 g/m² and not more than 55 g/m² (conforming to area density of CGSB-4-GP-81M).

| | | | |
|--|---|-----------------|--|
|  Health Santé Canada Canada | Title of publication-Titre de la publication Product Safety Reference Manual Book 5 - Laboratory Policies and Procedures | Page C23.3-3 | Effective En vigueur 2003-03-06 |
| Chapter and/or Section;-Number and title-Chapitre ou section-Numéro et titre Part B: Test Methods Section, Method C-23.3 DETERMINATION OF THE FLAME PROJECTION AND FLASHBACK OF CONTROLLED PRODUCTS | | | Amendment number- Numéro de la modification 31 |

4 SAFETY REQUIREMENTS

- 4.1 Two analysts should be present when the test is performed.
- 4.2 Safety glasses and face masks (especially with chlorinated samples) should be worn.
- 4.3 A water spray-pump and fire extinguisher should be available.

5 SAMPLING

5.1 Test Specimen

- 5.1.1 Where manufacturer's instructions respecting the shaking of the aerosol container exist, a test comprised of 3 discharges from each of 3 specimens of the same product and of the same size shall be conducted in accordance with par. 6.5.
- 5.1.2 Where manufacturer's instructions respecting the shaking of the aerosol container do not exist, a test comprised of 3 discharges from the container without shaking and subsequently, 3 discharges after shaking in accordance with subpar. 6.5.1, from each of 3 specimens of the same product and of the same size shall be conducted.

5.2 Conditioning

- 5.2.1 Each aerosol container shall be conditioned to a temperature of $22 \pm 2^\circ\text{C}$ and a discharge shall be released for 5 seconds from each specimen prior to testing.

6 EXPERIMENTAL PROCEDURE

- 6.1 A test shall be conducted at a temperature of $22 \pm 2^\circ\text{C}$ in the absence of air currents with an allowance made for a clearance of 50 cm beyond the support framework set at a distance of 45 cm from the burner (*Note 3*).
- 6.2 Install the first aerosol container in the flammability tester and ensure that the burner orifice is 15 cm from the discharge orifice of the container in the horizontal plane and 5 cm below in the vertical plane and that the discharge orifice points in the direction of the burner.
- 6.3 Adjust the burner to give a flame height of 5 cm and release a trial discharge from the aerosol container and, if no flame projection occurs, lower the burner orifice by 5 cm and

Note 3: It has been found satisfactory to conduct the test in a fume hood with the exhaust fan turned off and the protecting door lowered. Adequate fire extinguishing equipment should be readily available.

| | | | |
|--|--|-----------------|--|
|  Health Canada / Santé Canada | Title of publication-Titre de la publication Product Safety Reference Manual Book 5 - Laboratory Policies and Procedures | Page C23.3-4 | Effective En vigueur 2003-03-06 |
| Chapter and/or Section;-Number and title-Chapitre ou section-Numéro et titre Part B: Test Methods Section, Method C-23.3 DETERMINATION OF THE FLAME PROJECTION AND FLASHBACK OF CONTROLLED PRODUCTS | | | Amendment number-Numéro de la modification 31 |

adjust the burner to give a flame height of 12 cm. In such a case, proceed therefore with the burner adjusted to 10 cm below the discharge orifice with a 12 cm flame height.

- 6.4 Attach the cheesecloth to the flammability tester with bulldog clips or in any other suitable manner (*Note 4*) so as to cover the entire internal space of the support framework set at a distance of 15 cm from the burner. Verify that the cheesecloth is at the proper horizontal distance from the vertical plane of the burner orifice, and adjust the height of the support framework so that the cheesecloth will intercept the line of the flame projection.
- 6.5 Prepare the aerosol container in accordance with the manufacturer's instructions and
- 6.5.1 if shaking is applicable,
 - 6.5.1.1 shake vigorously for 5 seconds, or for the period of time specified in the manufacturer's instructions,
 - 6.5.1.2 install the container in the flammability tester, and
 - 6.5.1.3 15 seconds after cessation of shaking, release a discharge in accordance with par. 6.6; or
 - 6.5.2 if shaking is not applicable, install the container in the flammability tester and release a discharge in accordance with par. 6.6.
- 6.6 Release a discharge
- 6.6.1 until the valve of the aerosol container has been open for 5 seconds; or
 - 6.6.2 where any part of the cheesecloth ignites before the end of 5 seconds, until the time of such ignition, and
 - 6.6.3 during discharge, observe and evaluate to the nearest 1 cm the length of any flashback.
- 6.7 After each discharge, all fumes shall be exhausted and the residue cleaned up. Continue with each subsequent discharge in the following manner,
- 6.7.1 if shaking is applicable, repeat the procedure referred to in subpar. 6.5.1;
 - 6.7.2 if shaking is not applicable, release the discharge in accordance with par. 6.6. Allow the container to stand for at least 60 seconds between discharges.
- 6.8 Where the cheesecloth attached to the support framework set at a distance of 15 cm from the burner ignites, the remaining discharges referred to in par. 5.1 shall be conducted in accordance with paragraphs 6.1 to 6.7, but with a new piece of cheesecloth attached to the support framework set at a distance of 45 cm from the burner.

Note 4: In the interest of efficient operation, the use of the cheesecloth should be used for the initial discharge, however, if the cheesecloth ignites, further observation may be performed by visual measurement. However, when testing official samples or when the observed flame projection is within 5cm of a regulatory limit distance, a cheesecloth barrier shall be used as prescribed.

| | | | |
|--|---|-----------------|--|
|  Health Canada / Santé Canada | Title of publication-Titre de la publication Product Safety Reference Manual Book 5 - Laboratory Policies and Procedures | Page C23.3-5 | Effective En vigueur 2003-03-06 |
| Chapter and/or Section;-Number and title-Chapitre ou section-Numéro et titre Part B: Test Methods Section, Method C-23.3 DETERMINATION OF THE FLAME PROJECTION AND FLASHBACK OF CONTROLLED PRODUCTS | | | Amendment number-Numéro de la modification 31 |

7 DETERMINATION AND REPORTING

- 7.1 Where, at any time during the test, the cheesecloth mounted at a distance of 45 cm from the burner in accordance with par. 6.8 is ignited, the length of the flame projection shall be reported to be 45 cm or more.
- 7.2 Where, at any time during the test, the cheesecloth mounted at a distance of 15 cm from the burner in accordance with par. 6.4 is ignited but the cheesecloth mounted at a distance of 45 cm from the burner in accordance with par. 6.8 is not ignited, the length of the flame projection shall be reported to be 15 cm or more but less than 45 cm.
- 7.3 Where, at any time during the test, the cheesecloth mounted at a distance of 15 cm from the burner in accordance with par. 6.4 is not ignited, but there is a flame projection, the length of the flame projection shall be reported to be less than 15 cm.
- 7.4 The following results observed from any of the test discharges shall be reported:
 - 7.4.1 the length of the flame projection (*see Note 4*);
 - 7.4.2 the absence of flame projection;
 - 7.4.3 the occurrence and if so the length of any flashback.
- 7.5 Where applicable, the test results shall be reported according to the following format:

| <i>Sample no.</i> | <i>Specimen no.</i> | <i>Discharge no.</i> | <i>Flashback (cm)</i> | <i>Flame projection (cm)</i> |
|-------------------|---------------------|----------------------|-----------------------|------------------------------|
| SR# | 1A | 1 | 5 | ≥45 |

8 QUALITY CONTROL PROCEDURES

- 8.1 Apparatus is calibrated as required.

9 PRECISION AND ACCURACY

- 9.1 There is no known certified control sample available for this test.

..... END