

# A BOUT YOUR HOUSE

CE 19

## INSULATING YOUR HOUSE

While previous generations may have been content to live in drafty houses, most people now want comfortable warm houses. A healthy house today is well-sealed, well-insulated and properly ventilated.

A well-insulated house is a bit like dressing for the weather. A wool sweater will keep you warm if the wind is not blowing and it is not raining. On a windy, rainy day, wearing a nylon shell over your wool sweater helps keep you reasonably dry and warm. A house is similar. On the outside, underneath the brick or siding, there is an air barrier that does the same thing as the nylon—it keeps the wind from blowing through. Then there is the insulation (like your sweater) and then a vapour barrier, which helps keep moisture away from the house structure where it can do damage.

### Signs of insulation problems

#### In the winter

- walls cold to touch
- cold floors
- high heating costs
- uneven heating levels within building
- mold growing on walls

#### In the summer

- uncomfortably hot inside air
- high cooling costs
- ineffectiveness of air conditioning system
- mold growing in basement

### Insulation effectiveness

R-values—and their metric equivalent, RSI-values—are a way of labeling the effectiveness of insulating materials. The higher the R-value or RSI-value the more resistance the material has to the movement of heat. Insulation products sold in Canada are labeled with R and RSI-values. Provincial building codes specify minimum R (or RSI) values for new construction, with different values for different applications. It is important to know what your local building code requires when planning new construction.

Note that the way the insulation is installed plays a large role in its effectiveness. Compressing the insulation, leaving air spaces around the insulation and allowing air movement in the insulation all reduce the actual R-value of the insulation.



HOME TO CANADIANS  
Canada

Insulation material	R/in. (RSI/m)	Appearance	Advantages-Disadvantages
<b>Batt type</b>			
Fibreglass	3.0-3.7 (21-26)	All batts come in plastic wrapped bales. The products are like fibrous blankets, about 1.2 m (48 in.) long and wide enough to fit snugly between wall studs	Readily available.
Mineral wool	2.8-3.7 (19-26)	Same as fibreglass.	Somewhat better fire resistance and soundproofing qualities than glass fibre.
Cotton	3.0-3.7 (21-26)		Not readily available.
<b>Loose fill</b> (All loose fill typically requires professional installer)			
Glass fibre	3.0-3.7 (21-26)	A very light fibrous fill, usually pink or yellow.	Can be affected by air movement in attics.
Mineral fibre	2.8-3.7 (19-26)	A very light fibrous fill, usually brown.	
Cellulose Fibre	3.0-3.7 (21-26)	Fine particles usually gray in colour; more dense than glass or mineral fibre.	Provides more resistance to air movement than other loose fill insulations. Can have settlement problems if not installed properly.

Insulation material	R/in. (RSI/m)	Appearance	Advantages-Disadvantages
<b>Board stock</b>			
Type I and II (expanded) polystyrene or EPS	3.6-4.4 (25-31)	White board of small (about 8mm—0.3 in.—diameter) foam beads pressed together:	Typically no HCFC's used in production. Must be covered.
Type III and IV (extruded) polystyrene or XPS	5.0 (35)	Commonly blue or pink homogeneous foam board.	Works well in wet conditions, can act as a vapour retarder. HCFC (an ozone depleter and greenhouse gas) usually used in production. Must be covered.
Rigid fibreglass	4.2-4.5 (29-31)	A dense mat of fibres, typically less rigid than the polystyrene.	Drains water away. Sometimes hard to find.
Rigid mineral fibre	4.2-4.5 (29-31)	See rigid glass fibre above.	Drains water away.
Polyisocyanurate	5.6-7.7 (39-53)	Foil-faced rigid foam.	HCFC usually used in production.
<b>Spray applied</b>			
All spray applied insulations fill cavities very well. They must be applied by specialized contractor			
Wet spray cellulose	3.0-3.7 (21-26)	Fine particles held in place by a binder:	
Polyisocynene	3.6 (25)	A fairly rigid foam that expands into the cavity.	Can act as the air barrier and vapour retarder. Must be covered.
Polyurethane	5.8-6.8 (40-47)	A fairly rigid foam that expands into the cavity.	Similar to polyisocynene but HCFC's and greenhouse gases used in production and installation.

**Note: All values are approximate and for general comparison only.**

Some insulations may be irritants or hazardous during installation. Consult manufacturers' recommendations and insulation packaging for proper respiratory, eye and skin protection.

## Effective insulation systems

Effective insulation systems slow the movement of heat and deal with the movement of moisture at a reasonable cost. To do this they have:

- an air barrier which prevents the movement of interior or exterior air through the system.
- carefully filled cavities which leave no gaps in or around the insulation and which do not compress the insulation.
- a minimum of thermal bridges. These are parts of the wall that, with a lower R-value, extend from the warm side to the cold side of the insulation, giving heat an easy escape. The structural members in the wall will often be thermal bridges.
- a vapour retarder, such as polyethylene sheeting, which prevents moisture from moving from warm interior spaces into a colder building envelope where it could condense.
- drying potential, which is the ability of the insulated assembly to release any moisture that gets into the system.

## Wall insulation for new construction

Typically this is a wood frame wall with the potential for insulation in the stud cavity (batts or spray-applied) and on the exterior face of the studs (any of the rigid insulation). See the attached sketch of an example. During planning and installation note that:

- The vapour retarder should be at or near the inside surface of the insulation and would most commonly be 6 mil polyethylene sheeting at the inside face of the studs or vapour retardant paint on the finished drywall.
- The air barrier can be provided by the polyethylene vapour retarder, by the interior drywall or by air barrier sheeting on the exterior face of the studs. In all cases, the air barrier must be carefully detailed to be continuous at all penetrations.
- Adding rigid (board stock) insulation to the outside face of the studs minimizes thermal bridging as does spacing the studs at 610 mm (24") rather than 406 mm (16") where possible.

## Wall insulation for existing construction

The two most common wall types are wood-frame and solid brick. In a wood-frame wall, insulation (loose fill and some foams) is typically blown into the cavities through holes that have been drilled through the drywall or siding. In solid brick the largest cavity is usually 25 mm (1 in.) wide, which is not enough for any significant increase in R-value. The builder must create a cavity. Usually, a new cavity wall is built inside and insulated as a new wall, or board stock and new siding are applied to the exterior. When planning a cavity wall retrofit remember that:

- The cost of getting at and repairing the walls is a significant part of the work and cost of the project.
- Both air and vapour barriers are required. The interior painted drywall can be both an air and vapour barrier, but details at windows, electrical outlets, floors and other penetrations must be done carefully to reduce air movement through the wall as much as possible. Air movement can lead to mold growth and decay of the walls as well as loss of insulation efficiency.
- An insulation must be selected that will completely fill the cavity and not settle. Some insulations, such as foams, can provide reasonable air barriers themselves.

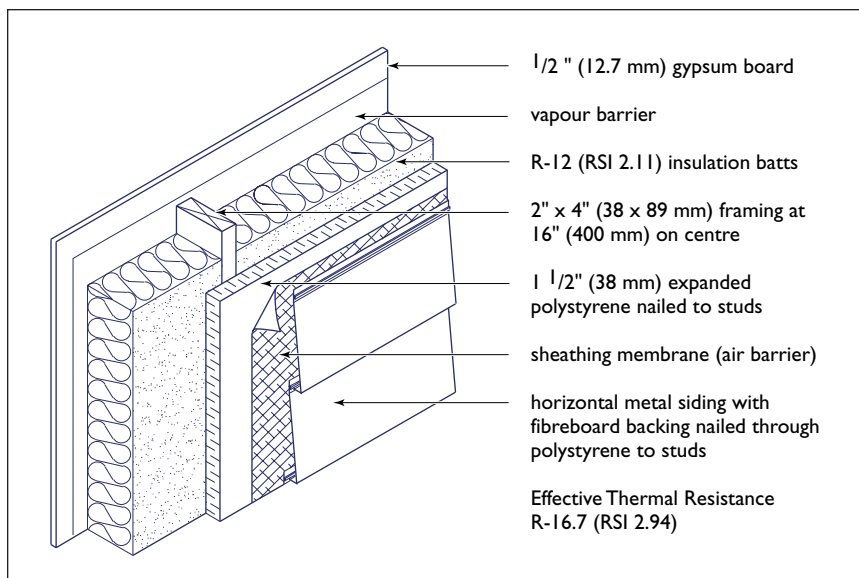

## Attic insulation

The attic is often the most cost-effective place to add insulation. Usually, a contractor blows loose fill into and over top of the ceiling joists. For the do-it-yourselfer, batts laid sideways on existing insulation are an easy alternative.

- The air barrier at the ceiling line must be tight to ensure warm moist air from the house does not get into the cold attic and condense in the winter. Check ceiling light fixtures, the tops of interior walls and penetrations such as plumbing stacks for air leakage.
- Ensure that soffit venting is not blocked by added insulation; baffles may have to be installed.

## Basement insulation

Basement walls are unique because they must handle significant flows of moisture from both inside and outside the house. The preferred method, from a building science perspective, is to insulate the wall on the outside with rigid insulation suitable for below-grade installations—such as extruded polystyrene or rigid fibreglass. The advantages are:

- Insulating the outside of the basement works well with dampproofing and foundation drainage. Rigid fibreglass or mineral wool acts as a drainage layer, keeping surface and ground water away from the foundation.
- The basement walls are kept at room temperature protecting the structure, reducing the risk of interior condensation and increasing comfort.

The disadvantages are the disturbance of landscaping, the need to cover the insulation above grade, and the relatively high cost.

Interior insulation can be used. This can be done when finishing the basement by using batt insulation in the stud cavities or by installing extruded polystyrene and strapping on the face of the perimeter walls. If the basement won't be finished, install rolls of polyethylene-encapsulated fiberglass over the wall. The advantages of interior installation are cost and ease of construction. The disadvantages of interior installations are:

- The basement walls are now at the temperature of the soil or the outside. Any moist air moving through the wall from the inside will condense on the wall.
- Usually there is a moisture barrier against the foundation wall and a vapour retarder on the room side of the insulation. As a result, the wall has poor drying potential.

Never apply interior insulation to a basement with moisture problems. Fix the moisture entry problems before insulating.

## Is it cost-effective to insulate?

The right insulation system can save you money, reduce the amount of energy you use and make your home more comfortable. Keep in mind that installation costs (including changes to the framing, cladding, and finishes) are usually the most expensive part of an insulation project. The local climate has an impact on the cost-effectiveness of any insulating project.

Check the cost, heat loss and heat gain of all the available options. Review all details to ensure that moisture movement is handled correctly. You can then select the right insulating system. When in doubt, consult a professional.

## The final analysis

If your home is poorly insulated, it usually pays to upgrade the insulation. If you are building a new home, it makes sense to insulate well now so you don't need to retrofit later.

---

### Other useful information from Canada Mortgage and Housing Corporation

Canadian Wood-Frame House Construction	\$25.95	NHA 5031
Healthy Housing Renovation Planner	\$34.95	NHA 2172

### To order these publications and to find out about other CMHC publications, contact:

Your local CMHC office  
or  
Canada Mortgage and Housing Corporation  
700 Montreal Road  
Ottawa ON K1A 0P7  
Phone: 1 800 668-2642  
Fax: 1 800 245-9274

Visit our home page at [www.cmhc-schl.gc.ca](http://www.cmhc-schl.gc.ca)