

Special requirements for equipment or loads extending beyond the end of vehicles equipped with a roll-on roll-off

In order to ensure the safety of road users, sections 473 and 474 of the *Highway Safety Code* prescribe limits and require the installation of devices for road vehicles whose load or equipment exceeds their length or width. You will find these sections at the end of this bulletin, which specifies how they apply to equipment or a load extending beyond the end of a vehicle equipped with a roll-on roll-off.

The rear end of a vehicle equipped with a roll-on roll-off is, in fact, the back end of the chassis frame side rails where the rear lights of these vehicles usually are. The overhang is measured starting at that point. The rail (tilt subframe) on which the removable container slides during loading and unloading operations is considered equipment. The overhang is therefore measured starting at the farthest point of the chassis frame side rail of the vehicle to the farthest point of either the load (container) or the equipment (rail). The following illustration shows the main components to be taken into consideration when determining the overhang.

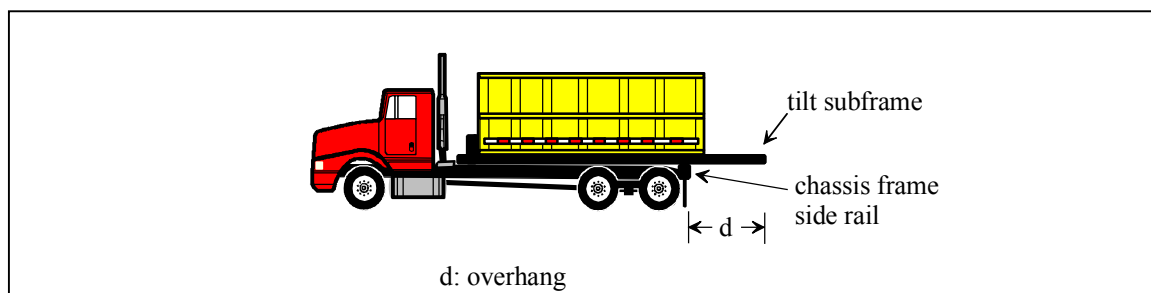

When the overhang is one metre or less, there are no special requirements. This is the case of certain telescopic roll-on roll-offs. However, when the rear end of the load or equipment extends beyond the end of the vehicle by more than one metre at its farthest point, section 474 du *Highway Safety Code* prescribes the installation of a red flag or a reflector panel during the day, and, at night, a red light visible from behind and from the sides for not less than 150 metres.

A Class 1 special permit is required when the overhang is more than two metres (section 473). The special permit is only valid when the vehicle is being operated without a load or with a load composed of a single item (empty container).

A member firm of RÉSEAU environnement, in collaboration with the ministère des Transports, designed a system that complies with the requirements of section 474 du *Highway Safety Code* while minimizing the operation costs involved in its application. The system was installed on several vehicles during the last few months in order to demonstrate how efficient it is. Appended to this bulletin, as information, you will find a technical drawing showing the details of the system. In order to allow owners to make the appropriate adjustments to their vehicles, the ministère des Transports and the Société de l'assurance automobile du Québec, in conjunction with the trucking industry, have agreed upon a transition period, i.e. until November 15, 2001, before the strict enforcement of section 474 of the *Highway Safety Code*.

For further information regarding this bulletin or vehicle load and size limits, call Info-camionnage at the telephone numbers at the bottom of the first page of this bulletin.

APPENDIX

Section 473. Prohibition

No owner or lessee of a road vehicle or operator of a heavy vehicle shall allow a road vehicle or combination of road vehicles to be operated if its load or equipment exceeds its width, including the width of its mandatory accessories, or exceeds its length by more than 1 metre at the front or 2 metres at the rear.

However, a special permit may be issued

- (1) to authorize equipment or a load of an indivisible nature where the person meets the requirements of a regulation under paragraph 20 of section 621;
- (2) to authorize equipment or any load where the person meets the conditions of an authorization by the Minister under section 633.

This section does not apply to road vehicles used to level, clear or mark the roadway when they are being operated for construction or maintenance work on a public highway.

Section 474. Red flag or reflector panel

No person may drive a road vehicle or combination of road vehicles whose load or equipment extends beyond the rear of the road vehicle or combination of road vehicles by more than 1 metre at its farthest point unless a red flag or a reflector panel, and, at night, a red light visible from behind and from the sides for not less than 150 metres is installed at the farthest point. The flag or reflector panel and their installation must comply with any standards that may be prescribed by regulation.

The devices required under the first paragraph may be replaced by an amber light that meets the standards prescribed by regulation.

Retractable light for a vehicle equipped with a roll-on roll-off

Design of a retractable light system for a truck or semi-trailer equipped with a roll-on roll-off

Type of light suggested.
Visible from behind and from the sides for not less than 150 metres.



A reflective band must be installed between the lights.

Tube-shaped light support
3" x 2" x 1/8"

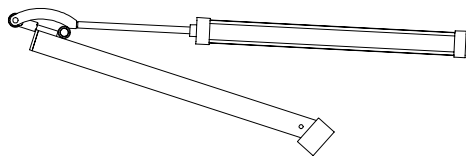

Retracted light

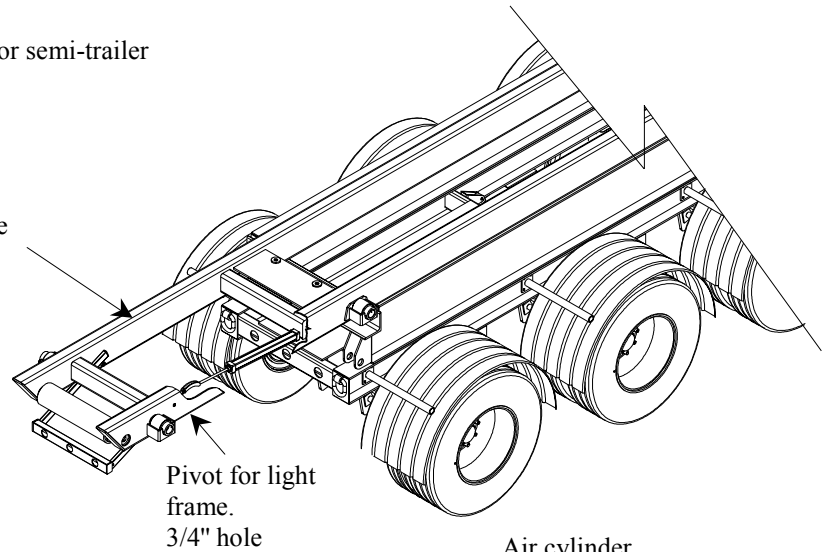

Air cylinder
SMC NCA1B200 or equivalent

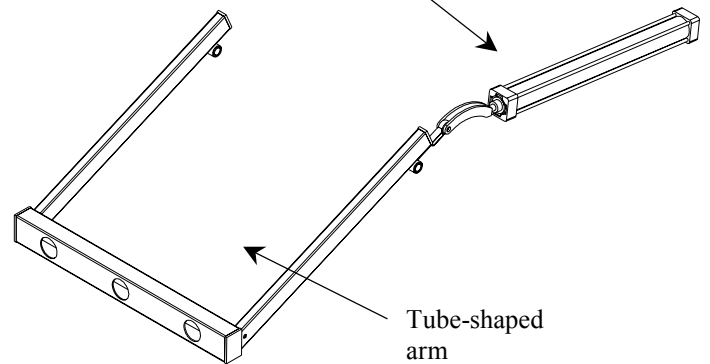

Tube-shaped arm
2" x 1" x 1/8"

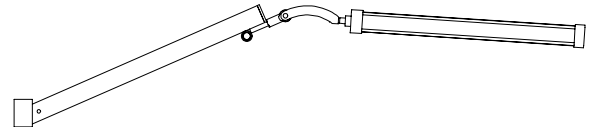

Extended light

